

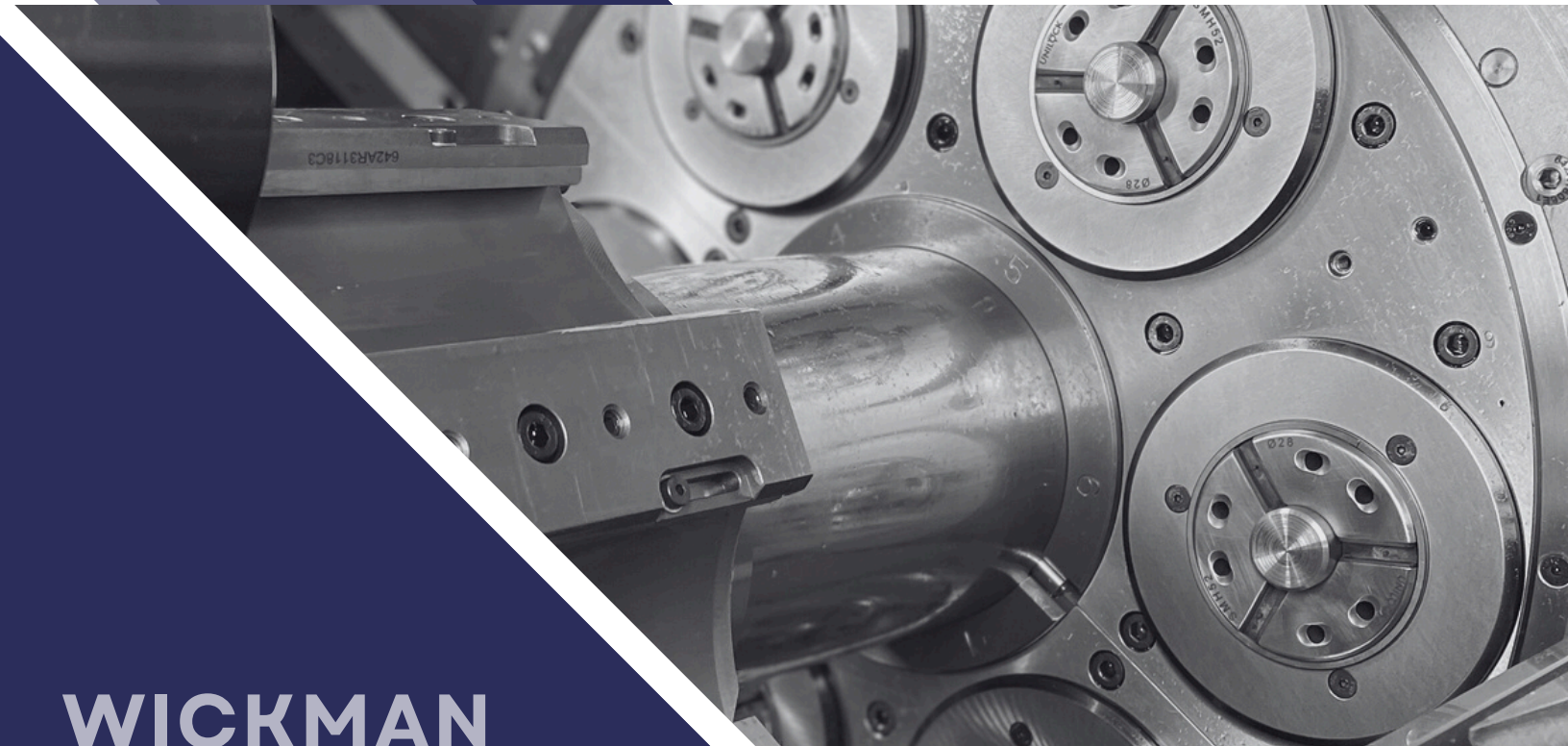

PIÈCES DÉTACHÉES



WICKMAN

2" 1/4-6

2" -6

TAJMAC-FRANCE

2¼"-6, 2¼"-6D, 2"-6, and 2"-6D BAR MACHINES

6¼"-6, 6¼"-6D CHUCKING MACHINES

GENERAL INDEX

SECTION	Drawing No.	Plate No.	SECTION	Drawing No.	Plate No.
Automatic Stop (Bar machines) 3rd Station	153Z2B	45	Cross Slides, (Bar machines) 6th Station	337Z1	29
Automatic Stop (Bar machines) 3rd Station	153Z1B	45	Cross Slides, (Bar machines) 3rd Station Forming	339Z1	34
Automatic Stop (Bar machines) 6th Station	353Z1	44	Cross Slides, (Bar machines) 3rd Station Part-off	339Z2	35
Automatic Stop (Bar machines) 6th Station	353Z1A	44A	Cross Slides (Chucking machines) 3rd Station	339Z3	36
Automatic Stop (Bar machines) 3rd Station	354Z1A	46A	Drum Locking	361Z1	53
Auxiliary Long. Slide Operation, Front and Rear	324Z1	25	End Bracket and Control Assembly)	314Z4A	7
Bar Feed (Bar machines)	358Z1	49	End Bracket and Control Assembly)	314Z4B	7A
Bar Feed (Bar machines)	358Z1A	49A	End Bracket and Control Assembly)	314Z4C	7B
Bar Feed (Double Bar Feed) 3rd Station	359Z1	50	End Bracket and Control Assembly)	314Z5A	8
Bar Feed (Double Bar Feed) 3rd Station	359Z1A	50A	End Bracket and Control Assembly)	314Z5B	8A
Bar Feed (Long) 2¼"-6, and 2"-6	360Z1	51	End Bracket and Control Assembly)	314Z5C	8B
Bar Feed (Long) 2¼"-6 only	360Z1A	51A	End Bracket and Control Assembly)	314Z6A	9
Bar Feed (Long) 2¼"-6 and 2"-6	360Z2	52	End Bracket and Control Assembly) Chucking Machines	314Z6B	9A
Bar Stop (Bar machines)	350Z1	42	End Bracket and Control Assembly)	314Z6C	9B
Bar Stop Rear (Bar machines)	351Z1	43	End Bracket and Control Assembly)	314Z15	10
Camshaft	344Z1	38	End Bracket and Control Assembly)	314Z15A	10A
Camshaft	344Z1B	38A	End Bracket and Control Assembly)	214Y7	11
Centre Block (Bar machines)	327Z1	26	End Bracket and Control Assembly)	214Y7A	11A
Centre Block (Chucking machines)	327Z2	27	End Bracket and Control Assembly)	214Y7C	11B
Centre Block Operation	323Z1	23	End Bracket and Control Assembly)	214Y8A	11C
Centre Block Operation	323Z2	24	Feed Brake Interlock	319Y4	22A
Chuck Operating Unit (Chucking machines)	514Y1	12	Feed Drive Gearing	318Z1	19
Clutch Adjusting Unit (Chucking machines)	304Z6	6	Electro-magnetic feed clutch and brake	318Z2A	19A
Collet Operation (Bar machines)	356Z1	47	Electro-magnetic feed clutch and brake	318Z3	19B
Collet Operation (Double Bar Feed) 3rd Station	357Z1	48	Electro-magnetic feed clutch and brake	318Z4A	19C
Coolant Pump	369Y1	57	Front Control Panel 6¼"-6D	514V13A	16
Coolant Pump Drive	369Z5	58	Front Control Panel 6¼"-6D	514V13C	16A
Coolant Pipes	369Z2A	58A	Front Control Panel 6¼"-6	514V3B	14
Cross Slide Operation	341Z1	30	Front Control Panel 6¼"-6	514V3D	14A
Cross Slide Operation	341Z2	31	Index Clutch Operation	345Z1	39
Cross Slide Operation	341Z3	32	Indexing Gears	346Z1	40
Cross Slide Operation	341Z4	33	Indexing Gears 6¼"-6D	349Z1	41
Cross Slides, Upper	335Z1	28	Lubrication	168Z1B	56
Cross Slides, Lower	342Z1	37	Machine Controls	319Z1	20

Continued.....

	SECTION	Drawing No.	Plate No.
Machine Controls	31925	20A
Machine Controls	31922	21
Machine Controls	31926	21A
Machine Controls	31926A	21B
Machine Controls (Chucking machines)	31923	22
Main Drive Gearing	31721	18
Motor Drive	31621	17
Motor Drive	31621B	17A
Relay-Panel (Chucking machines)	21422A	13
Relay-Panel (Chucking machines)	21422	13A
Solenoid Operated Valve 6 $\frac{1}{4}$ "-6	514Y12	15
Spindle Assembly 2"-6, 2"-6D	30121	1
Spindle Assembly 2 $\frac{1}{4}$ "-6, 2 $\frac{1}{4}$ "-6D	30123	1a
Spindle Assembly 2 $\frac{1}{4}$ "-6, 2 $\frac{1}{4}$ "-6D	30123A	1b
Spindle Assembly 2"-6, 2"-6D)	30122	2
Spindle Assembly 2 $\frac{1}{4}$ "-6, 2 $\frac{1}{4}$ "-6D)		
Spindle Stopping Assembly 2 $\frac{1}{4}$ "-6	30221	61
Spindle Stopping Assembly 2 $\frac{1}{4}$ "-6	30222	62
Spindle Stopping Assembly 2 $\frac{1}{4}$ "-6	30223	63
Spindle Stopping Assembly 2 $\frac{1}{4}$ "-6	30224	64
Spindle Arrangement (6 $\frac{1}{4}$ "-6 & 6 $\frac{1}{4}$ "-6D Chucking Machines)	30321B	3A
Spindle Arrangement (6 $\frac{1}{4}$ "-6 & 6 $\frac{1}{4}$ "-6D Chucking Machines)	30321C	3B
Spindle Arrangement (6 $\frac{1}{4}$ "-6, 6 $\frac{1}{4}$ "-6D	30322	4
Spindle Stopping Unit (Chucking machines)	30421	5
Stock Carriage, 2"-6, 2"-6D	37521	59
Stock Carriage, 2 $\frac{1}{4}$ "-6, 2 $\frac{1}{4}$ "-6D	37522	60
Swarf Chutes	36321	55
Swarf Conveyor	56321C	54
Swarf Conveyor	56321D	54A
Hydraulic & attachments Supplements at End of Book			

**WICKMAN
MULTI-SPINDLE
AUTOMATICS**

**SPINDLE ARRANGEMENT
2"-6 AND 2"-6D BAR MACHINES**

INDEX NO.	PART NO.	TITLE.	INDEX NO.	PART NO.	TITLE.
1	156/206	2 B.A. Socket Head Cap Screw, $\frac{1}{4}$ " long.	51	155/0628	$\frac{1}{4}$ " B.S.F. Socket Head Cap Screw, $1\frac{1}{2}$ " long.
2	154/03	2 B.A. Spring Washer.	52	194/1	$\frac{1}{4}$ " B.S.P. Socket Plug.
3	156/208	2 B.A. Socket Head Cap Screw, $\frac{1}{4}$ " long.	53	301X.147	Spindle Nose.
4	301X.158	Key.	54	301X.148	Driving Key for Collet.
5	141/14	Extractable Taper Pin, $\frac{1}{8}$ " dia., 2" long.	55	155/0628	$\frac{1}{4}$ " B.S.F. Socket Head Cap Screw, $1\frac{1}{2}$ " long.
6	301Z.109	Index Gear on Spindle Drum.	56	154/06	$\frac{1}{4}$ " Spring Washer.
7	301X.163	Thrust Block.	57	301V.114	Binding Cap, Front Bearings.
8	155/1248	$\frac{1}{4}$ " B.S.F. Socket Head Cap Screw, 3" long.	58	301X.116	Piston Ring.
9	154/12	$\frac{1}{4}$ " Spring Washer.	59	301X.115	Ring Housing.
10	301X.146	Locator.	60	301X.159	Spacer.
11	155/0620	$\frac{1}{4}$ " B.S.F. Socket Head Cap Screw, $1\frac{1}{2}$ " long.	61	143/0406D	$\frac{1}{4}$ " dia. Mills Grooved Pin, $\frac{3}{4}$ " long, G.P.4.
12	154/06	$\frac{1}{4}$ " Spring Washer.	62	301X.117	Front Bearing Spacer.
13	301X.156	Stop Screw.	63	143/0406D	$\frac{1}{4}$ " dia. Mills Grooved Pin, $\frac{3}{4}$ " long, G.P.4.
14	176/0506	$\frac{1}{4}$ " B.S.F. Hex. Head Set Screw, Cup Point, $\frac{3}{4}$ " long.	64	S.B.32	Front Spindle Bearings.
15	153/05	Soft Pad.	65	301X.118	Front Bearing, Rear Spacer.
16	141/10	Extractable Taper Pin, $\frac{3}{16}$ " dia., 2" long.	66	301X.119	Spacer.
17	301Z.101	Spindle Drum.	67	301X.144B	Binding Nut (Front Spindle Bearings).
18	317X.141	Centre Guide.	68	301X.154	Collet Tube.
19	317X.142	Threaded Taper Pin.	69	301X.155	Feeder Tube.
20	317Y.140	Centre Driving Shaft.	70	301Z.102	Work Spindle.
21	203/08L	$\frac{1}{4}$ " B.S.F. Self-Locking Nut (Thin).	71	172/110	Slotted Locknut, 16 T.P.I., 110 mm.
22	130/08	$\frac{1}{4}$ " dia. Flat Washer.	72	176/0506	$\frac{1}{4}$ " B.S.F. Set Screw, Cup Point, $\frac{3}{4}$ " long.
23	301V.136	Centre Shaft Gear.	73	153/05	Soft Pad.
24	121/2056T	$\frac{1}{4}$ " Square Tapped Key, $3\frac{1}{4}$ " long.	74	301X.189	Drive Pin.
25	257/60	Medium Type Ball Journal, 60 x 130 x 31 mm.	75	301V.112	Spindle Gear.
26	317X.154	Centre Bearing, Inner Spacer.	76	301X.113	Spindle Gear Centre.
27	317X.145	Binding Plate.	77	102/44P	Internal Circlip, 5".
28	155/0828	$\frac{1}{4}$ " B.S.F. Socket Head Cap Screw, $1\frac{1}{2}$ " long.	78	301X.120	Rear Bearing Cover and Spacer.
29	154/08	$\frac{1}{4}$ " B.S.F. Spring Washer.	79	301X.123	Rear Bearing Spacer.
30	301Y.165	Driving Coupling.	80	301X.179	Rear Bearing Spacer.
31	317X.144	Bolt.	81	143/0406D	$\frac{1}{4}$ " dia. Mills Grooved Pin, $\frac{3}{4}$ " long, G.P.4.
32	198/16	$\frac{1}{4}$ " dia. Internal Shakeproof Washer.	82	301X.124	Spacer.
33	—	Soft Iron Wire.	83	S.B.31	Rear Spindle Bearings.
34	129/29	Welch Plug Washer, $2\frac{1}{4}$ " dia.	84	155/0724	$\frac{1}{4}$ " B.S.F. Socket Head Cap Screw, $1\frac{1}{2}$ " long.
35	301X.191	Plunger Spring.	85	154/07	$\frac{1}{4}$ " Spring Washer.
36	301X.129	Plunger.	86	301X.120	Rear Bearing Cover and Spacer.
37	125/1008	$\frac{1}{4}$ " Taper Pin, $\frac{1}{2}$ " long.	87	301Y.111	Toggle Operating Sleeve.
38	182/0516	$\frac{1}{4}$ " B.S.F. Set Screw, Taper Point, 1" long.	88	171/56	Slotted Locknut, 16 T.P.I., $3\frac{1}{2}$ "
39	301X.105	Pin for Toggle.	89	176/0506	$\frac{1}{4}$ " B.S.F. Set Screw, Cup Point, $\frac{3}{4}$ " long.
40	301V.104B	Toggle.	90	153/05	Soft Pad.
41	301X.106	Pin for Toggle Roller.	91	301Z.110	Toggle Carrier.
42	301X.107	Toggle Roller.	92	301X.127A	Thrust Ring.
43	154/06	$\frac{1}{4}$ " B.S.F. Spring Washer.	93	301X.122A	Compensating Washer.
44	301X.150	Retaining Screw.	94	301X.190	Washer.
45	301X.173	Parallel Pin.	95	155/0512	$\frac{1}{4}$ " B.S.F. Socket Head Cap Screw, $\frac{3}{4}$ " long.
46	317X.149	Centre Bearing, End Spacer.	96	154/05	$\frac{1}{4}$ " Spring Washer.
47	143/0406D	$\frac{1}{4}$ " dia. Mills Grooved Pin, $\frac{3}{4}$ " long.	97	301V.125A	Collet Tube Sleeve.
48	317X.153	Spacer.	98	301V.126	Adjusting Sleeve.
49	122/1648T	Tapped Key, $\frac{1}{4}$ " x $\frac{1}{16}$ " x 3" long.	99	301X.130	Support Bush for Feed Tube.
50	154/06	$\frac{1}{4}$ " Spring Washer.			

List of Parts for
PLATE No. I
(Drawing No. 301 Z I)

WHEN ORDERING SPARE PARTS ALWAYS QUOTE THE SERIAL NUMBER OF THE MACHINE

SPINDLE ARRANGEMENT 2"-6 AND 2"-6D BAR MACHINES

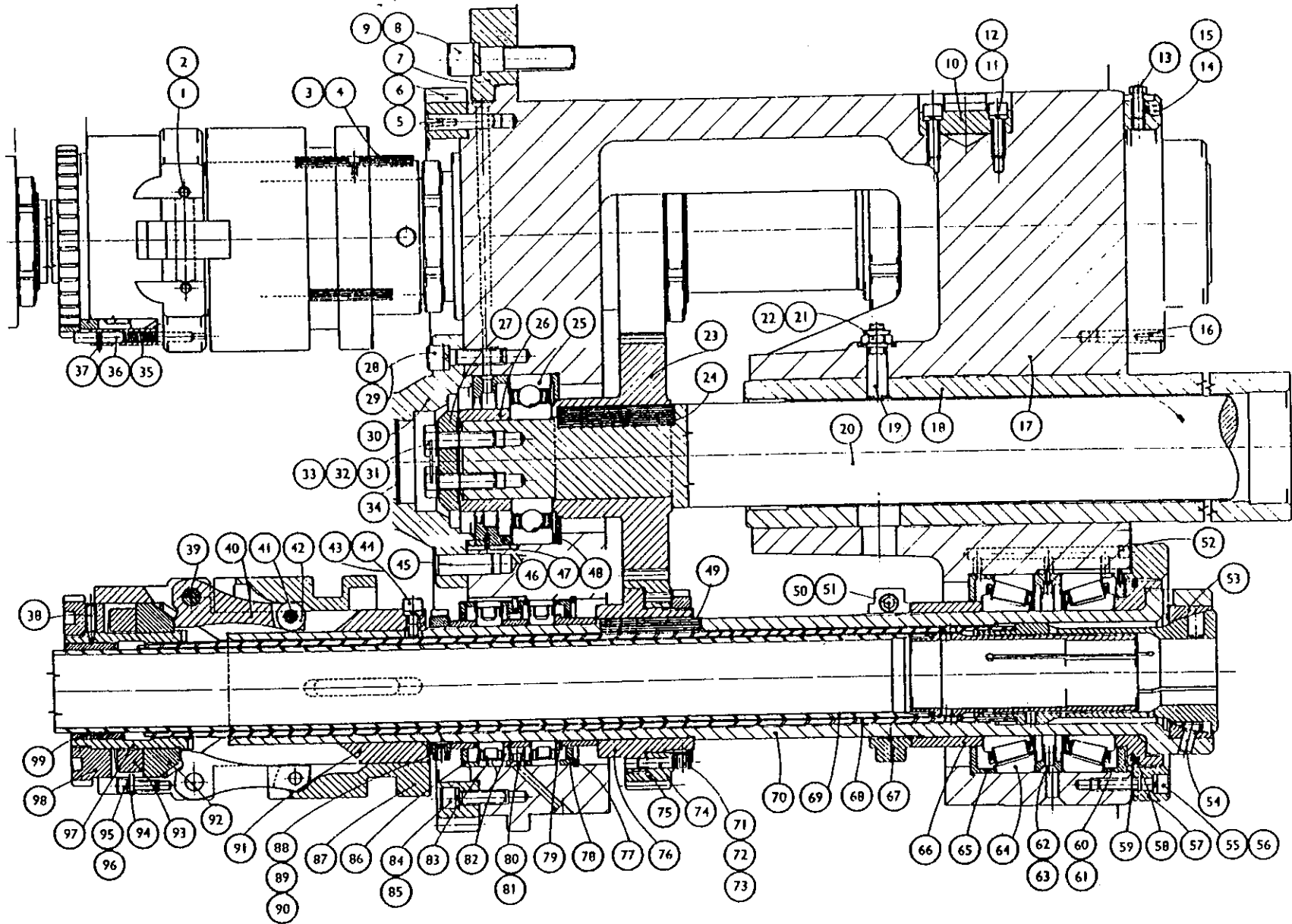

**WICKMAN
MULTI-SPINDLE
AUTOMATICS**

**SPINDLE ASSEMBLY
2 1/4"-6 AND 2 1/4"-6D BAR MACHINES**

INDEX NO.	PART NO.	TITLE.
1	154/03	2 B.A. Spring Washer.
2	156/206	2 B.A. Socket Head Cap Screw, 1/2" long.
3	156/208	2 B.A. Socket Head Cap Screw, 1/2" long.
4	301X.158	Key.
5	141/14	1/2" Taper Pin, "Extractable", 2" long.
6	301Z.109	Index Gear on Spindle Drum.
7	301X.163	Thrust Block.
8	154/12	1/2" Spring Washer.
9	155/1248	1/2" B.S.F. Socket Head Cap Screw, 3" long.
10	301X.146	Locator.
11	155/0620	1/2" Socket Head Cap Screw, 1 1/2" long.
12	154/06	1/2" Spring Washer.
13	301X.156	Stop Screw.
14	176/0506	1/8" B.S.F. Socket Set Screw, Cup Point, 1/2" long.
15	153/05	1/8" Soft Pad for Set Screws.
16	125/1008	1/2" Taper Pin, 1/2" long.
17	301X.129	Plunger.
18	301X.191	Plunger Spring.
19	122/1640T	Tapped Key, 1/2" x 1/2" x 2 1/2".
20	154/08	1/2" Spring Washer.
21	155/0828	1/2" B.S.F. Socket Head Cap Screw, 1 1/2" long.
22	301Y.165	Driving Coupling.
23	301V.136	Centre Shaft Gear.
24	301Z.101	Spindle Drum.
25	141/10	1/2" Taper Pin, "Extractable", 2" long.
26	182/0516	1/8" B.S.F. Socket Taper Point Set Screw, 1" long.
27	301X.105	Pin for Toggle.
28	301V.104B	Toggle.
29	301X.106	Pin for Toggle Roller.
30	301X.107	Roller for Toggle.
31	154/06	1/2" Spring Washer.
32	301X.150	Retaining Screw.
33	301X.173	Parallel Pin.
34	129/29	2 1/2" dia. "Welch" Plug Washer.
35	122/1648T	Tapped Key, 1/2" x 1/2" x 3".
36	154/06	1/2" Spring Washer.
37	155/0628	1/2" B.S.F. Socket Head Cap Screw, 1 1/2" long.
38	194/1	1/2" B.S.P. Socket Plug.
39	301X.147	Spindle Nose.
40	301X.162	Support Bush for Feeder Tube.
41	301V.126	Adjusting Sleeve.
42	301V.125A	Collet Tube Sleeve.
43	155/0512	1/8" B.S.F. Socket Head Cap Screw, 1/2" long.
44	154/05	1/2" Spring Washer.
45	301X.190	Washer.
46	301X.122A	Compensating Washer.
47	301X.127A	Thrust Ring.

INDEX NO.	PART NO.	TITLE.
48	301Z.110	Toggle Carrier.
49	153/05	1/8" Soft Pad for Set Screws.
50	176/0506	1/8" B.S.F. Socket Set Screw, Cup Point, 1/2" long.
51	171/56	16 T.P.I. Slotted Locknut, 3 1/2".
52	301Y.111	Toggle Operating Sleeve.
53	301X.120	Rear Bearing Cover and Spacer.
54	154/07	1/2" Spring Washer.
55	155/0724	1/2" B.S.F. Socket Head Cap Screw, 1 1/2" long.
56	S.B.31	Rear Spindle Bearings.
57	301X.124	Spacer.
58	143/0406D	1/2" dia. Mills Grooved Pin, 1/2" long, G.P.4.
59	301X.179	Rear Bearing Spacer.
60	301X.123	Rear Bearing Spacer.
61	301X.120	Rear Bearing Cover and Spacer.
62	102/44P	Internal Circlip, Ground Faces, 5" Bore.
63	301X.113	Spindle Gear Centre.
64	301V.112	Spindle Gear.
65	301X.189	Drive Pin.
66	172/110	16 T.P.I. Slotted Locknut 110 mm.
67	176/0506	1/8" B.S.F. Socket Set Screw, Cup Point, 1/2" long.
68	153/05	1/8" Soft Pad for Set Screws.
69	301Z.102A	Work Spindle.
70	301X.178A	Assembly of Bar Feed Sleeve and Feed Tube.
71	301X.170A	Collet Tube.
72	301X.144B	Binding Nut (Front Spindle Bearings).
73	301X.119	Spacer.
74	301X.118	Front Bearing Rear Spacer.
75	SB.32	Front Spindle Bearings.
76	143/0406D	1/2" dia. Mills Grooved Pin, 1/2" long, G.P.4.
77	301X.117	Front Bearing Spacer.
78	143/0406D	1/2" dia. Mills Grooved Pin, 1/2" long, G.P.4.
79	301X.159	Spacer.
80	301X.115A	Ring Housing.
81	301X.116	Piston Ring.
82	301V.114	Binding Cap, Front Bearings.
83	155/0628	1/2" B.S.F. Socket Head Cap Screw, 1 1/2" long.
84	154/06	1/2" Spring Washer.
85	102X.197B	Key.
86	301X.148	Driving Key for Collet.
87	301X.152	Binding Nut.
88	301X.174	Locknut.
89	151/75	22 T.P.I. Slotted Locknut 75 mm.
90	176/0506	1/8" B.S.F. Socket Set Screw, Cup Point, 1/2" long.
91	153/05	1/8" Soft Pad for Set Screws.
92	301X.178A	Assembly of Bar Feed Sleeve and Feed Tube.
93	258/75SS	Ball Journal Light Metric Shields, 75 mm.

LAST USED ON INSPECTION No. 14704

List of Parts for
PLATE No. 1a
(Drawing No. 301 Z 3)

WHEN ORDERING SPARE PARTS ALWAYS QUOTE THE SERIAL NUMBER OF THE MACHINE

SPINDLE ASSEMBLY
2 1/4"-6 AND 2 1/4"-6D BAR MACHINES

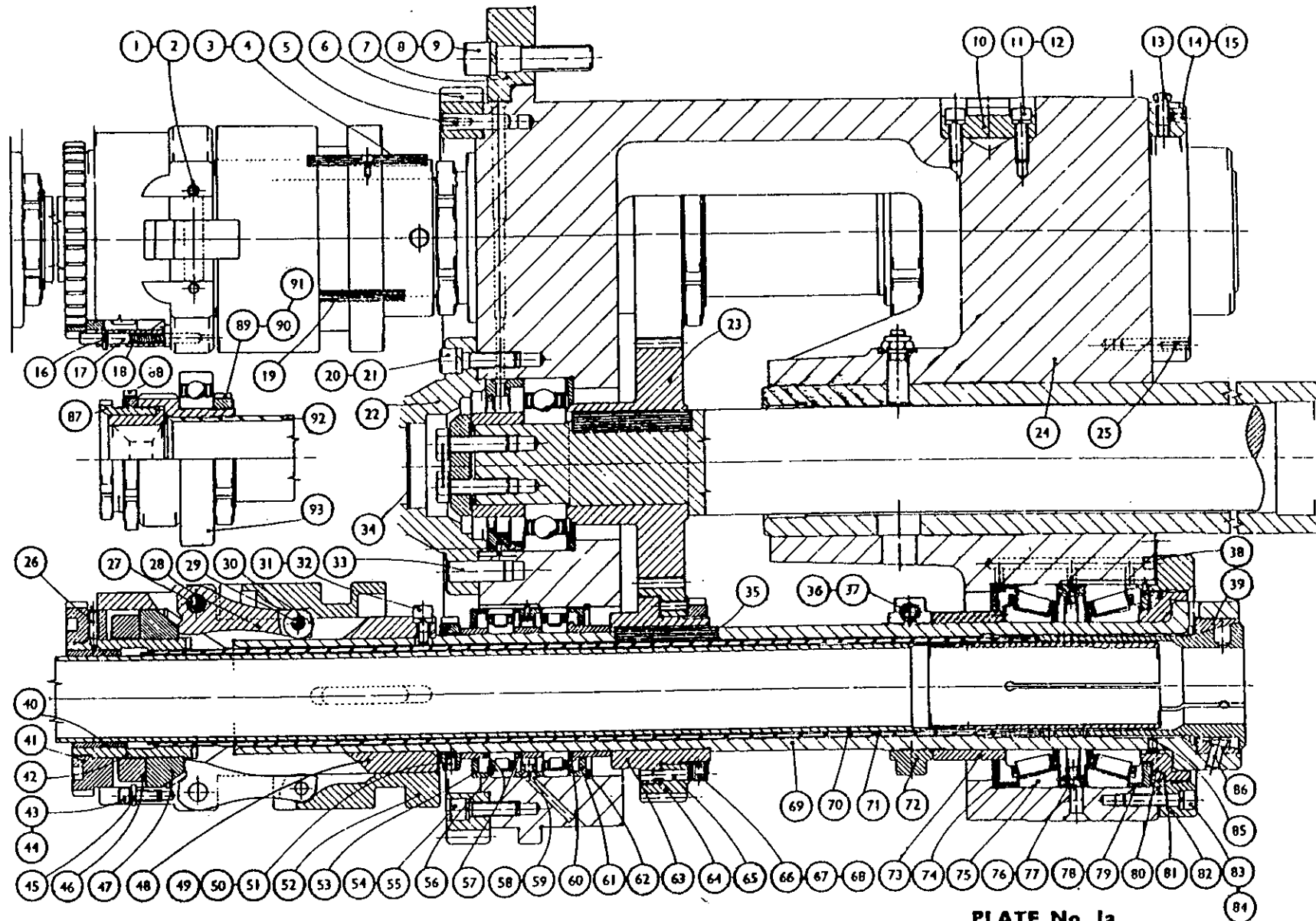

PLATE No. 1a
(Drawing No. 301 Z 3)

LAST USED ON INSPECTION No. 14704

**WICKMAN
MULTI-SPINDLE
AUTOMATICS**

SPINDLE ASSEMBLY

2¼"-6 AND 2¼"-6D BAR MACHINES WITH A.C. BEARINGS

INDEX NO.	PART NO.	TITLE	INDEX NO.	PART NO.	TITLE
1	154/03	Spring Washer, for 3/16" dia.	60	317X.149	Centre Bearing End Spacer
2	156/206	Socket Head Cap Screw, 2 B.A. x ¾" long	61	301X.112A	Spindle Gear
3	156/208	Socket Head Cap Screw, 2 B.A. x ½" long	62	102/44P	Internal Circlip, Ground Faces, 5" bore
4	301X.158	Key	63	301X.120	Rear Bearing Cover and Spacer
5	141/14	Taper Pin, Extractable, ½" dia. x 2" long	64	301X.123	Rear Bearing Spacer
6	301Z.109A	Index Gear on Spindle Drum	65	301X.179	Rear Bearing Spacer
7	301X.163	Thrust Block	66	143/0406D	Grooved Pin ("Mills"), GP 14, ¾" dia. x ¾" long
8	154/12	Spring Washer, for ¼" dia.	67	301X.124	Spacer
9	156/1248	Socket Head Cap Screw, ¼" B.S.F. x 3" long	68	S8 31	Rear Spindle Bearing
10	301X.146	Locator	69	166/0724	Socket Head Cap Screw, 7/16" B.S.F. x 1½" long
11	156/0620	Socket Head Cap Screw, ¾" B.S.F. x 1¼" long	70	154/07	Spring Washer, for 7/16" dia.
12	154/06	Spring Washer, for ¾" dia.	71	301X.120	Rear Bearing Cover and Spacer
13	301X.156	Stop Screw	72	301Y.11A	Toggle Operating Sleeve
14	176/0506	Socket Set Screw, Cup Point, 5/16" B.S.F. x ¾" long	73	171/56	Slotted Locknut, 3½", 16 T.P.I.
15	163/05	Soft Pad, for 5/16" B.S.F.	74	176/0506	Socket Set Screw, Cup Point, 5/16" B.S.F. x ¾" long
16	182/0412	Socket Set Screw, Taper Point, ¼" B.S.F. x ¾" long	75	153/05	Soft Pad, for 5/16" B.S.F.
17	301X.103	Thrower Ring	76	301Z.110A	Toggle Carrier
18	301V.136	Centre Shaft Gear	77	301X.127B	Thrust Ring
19	121/2058T	Key, Tapped, ¾" square x 3¼" long	78	301X.122B	Compensating Washer
20	130/08	Flat Washer, for ½" dia.	79	301X.190	Washer
21	203/08	Selflocking Nut, Thin, ½" B.S.F.	80	154/05	Spring Washer, for 5/16" dia.
22	317Y.140A	Centre Drive Shaft	81	155/0512	Socket Head Cap Screw, 5/16" B.S.F. x ¾" long
23	317X.142	Threaded Taper Pin	82	301V.125A	Collet Tube Sleeve
24	317Y.141C	Centre Guide	83	301V.128	Adjusting Sleeve
25	301Z.101A	Spindle Drum	84	301X.162	Support Bush for Feeder Tube
26	141/10	Taper Pin, Extractable, 11/32" dia. x 2" long	85	182/0516	Socket Set Screw, Taper Point, 5/16" B.S.F. x 1" long
27	301X.147	Spindle Nose	86	301X.105	Pin for Toggle
28	301X.148A	Driving Key for Collet	87	301X.104B	Toggle
29	154/06	Spring Washer, for ¾" dia.	88	301X.106	Pin for Toggle Roller
30	156/0628	Socket Head Cap Screw, ¾" B.S.F. x 1¼" long	89	301X.107	Roller for Toggle
31	303V.114B	Binding Cap for Spindle Front Bearing	90	SP 41/J	Tab Washer, for ¾" B.S.F.
32	301X.116	Piston Ring	91	9101X.117	Special Screw
33	302X.115B	Ring Housing	92	301X.173	Parallel Pin
34	302X.160	Labyrinth Ring	93	129/29	Welch Plug Washer, 2½" dia.
35	301X.139	Front Bearing Spacer, Inner	94	-	Soft Iron Wire
36	301X.140	Front Bearing Spacer, Outer	95	198/16	Shakeproof Lockwasher, for ½" dia.
37	143/0406D	Grooved Pin ("Mills"), GP 4, ¾" dia. x ¾" long	96	317X.144	Bolt
38	3B 64	Front Spindle Bearing	97	301Y.165A	Driving Coupling
39	301X.138	Front Bearing Rear Spacer	98	267/80	Ball Journal, Medium Type, 60mm, 130mm, 31mm
40	301X.137	Spacer	99	317X.154	Centre Bearing Inner Spacer
41	172/100	Slotted Locknut, 72mm, 22 T.P.I.	100	317X.145	Binding Plate
42	301/170A	Collet Tube	101	165/0828	Socket Head Cap Screw, ½" B.S.F. x 1¼" long
43	301X.161B	Feeder Tube	102	154/08	Spring Washer, for ½" dia.
44	301Z.102E	Work Spindle	103	122/1840T	Key, Tapped, ½" x 11/32" x 2½" long
45	176/0506	Socket Set Screw, 5/16" B.S.F. x ¾" long	104	-	Feed Tube Assembly, see 301V.177A
46	153/05	Soft Pad, for 5/16" B.S.F.	105	301X.191	Plunger Spring
47	122/1848T	Key, Tapped, ½" x 11/32" x 3" long	106	301X.129	Plunger
48	317X.153	Spacer	107	126/1008	Taper Pin, 5/32" dia. x 1" long
49	143/0406D	Grooved Pin ("Mills"), GP 4, ¾" dia. x ¾" long	108	-	Support Bush (to suit Tooling)

List of Parts for
PLATE No. 1b
(Drawing No. 301 Z 3A)

COMMENCING ON INSPECTION No. 14705

WHEN ORDERING SPARE PARTS ALWAYS QUOTE THE INSPECTION NUMBER OF THE MACHINE

SPINDLE ASSEMBLY

2 1/4"-6 AND 2 1/4"-6D BAR MACHINES WITH A.C. BEARINGS

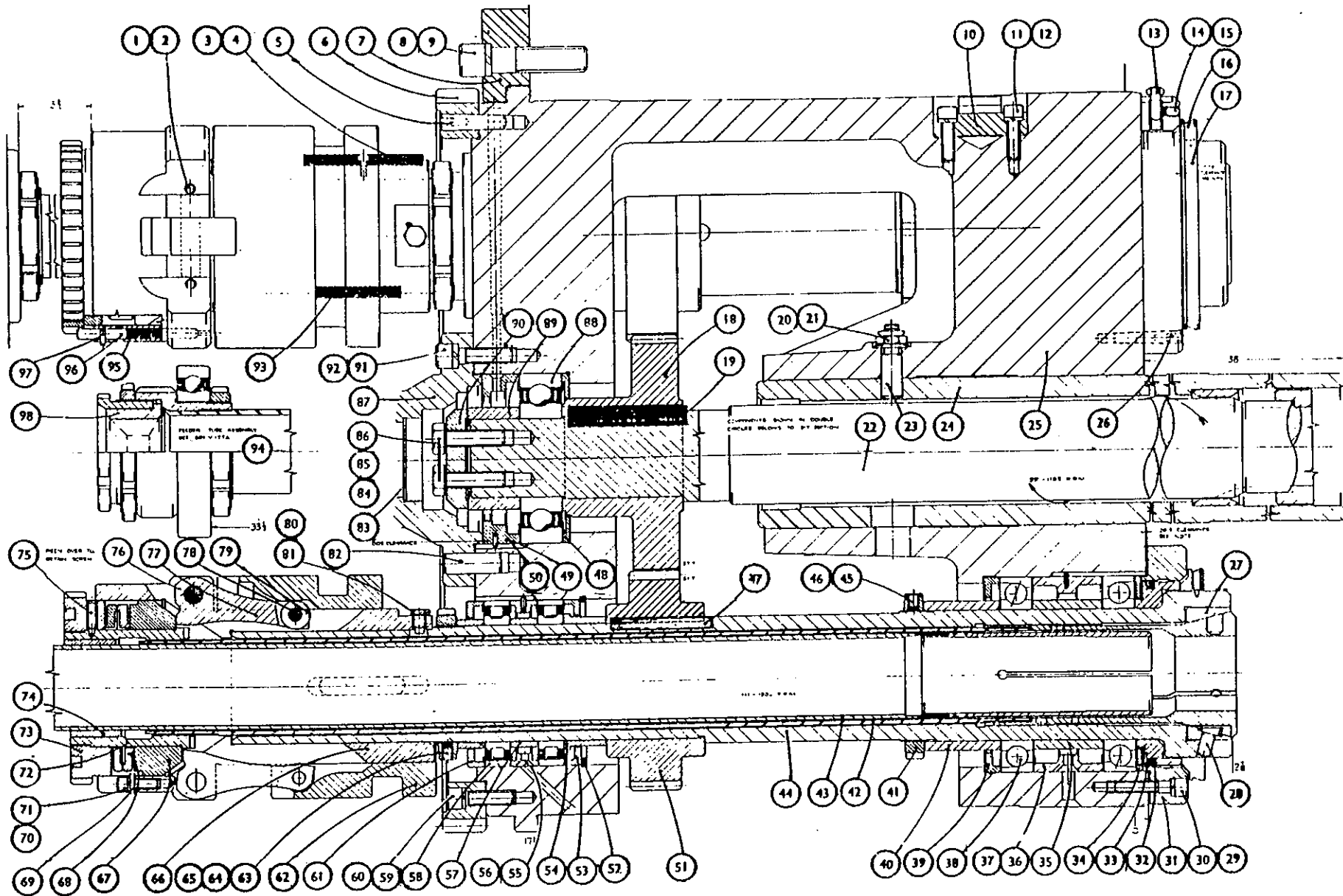

COMMENCING ON INSPECTION No. 14705

PLATE No. 1b
(Drawing No. 301 Z 3A)

**WICKMAN
MULTI-SPINDLE
AUTOMATICS**

SPINDLE ARRANGEMENT
2 $\frac{1}{4}$ "-6, 2 $\frac{1}{4}$ "-6D, 2"-6 AND 2"-6D BAR MACHINES

INDEX NO.	PART NO.	TITLE.
1	155/0720	$\frac{1}{4}$ " B.S.F. Socket Head Cap Screw, 1 $\frac{1}{2}$ " long.
2	154/07	$\frac{1}{8}$ " Spring Washer.
3	301X.180	Clamp for Rear Bearing Cap.
4	212/04	$\frac{1}{2}$ " B.S.F. Autolub Nipple.
5	210/1725	Indicator Washer (Yellow).

List of Parts for
PLATE No. 2
(Drawing No. 301 Z 2)

WHEN ORDERING SPARE PARTS ALWAYS QUOTE THE SERIAL NUMBER OF THE MACHINE

SPINDLE ASSEMBLY

2 1/4"-6, 2 1/4"-6D, 2"-6 AND 2"-6D BAR MACHINES

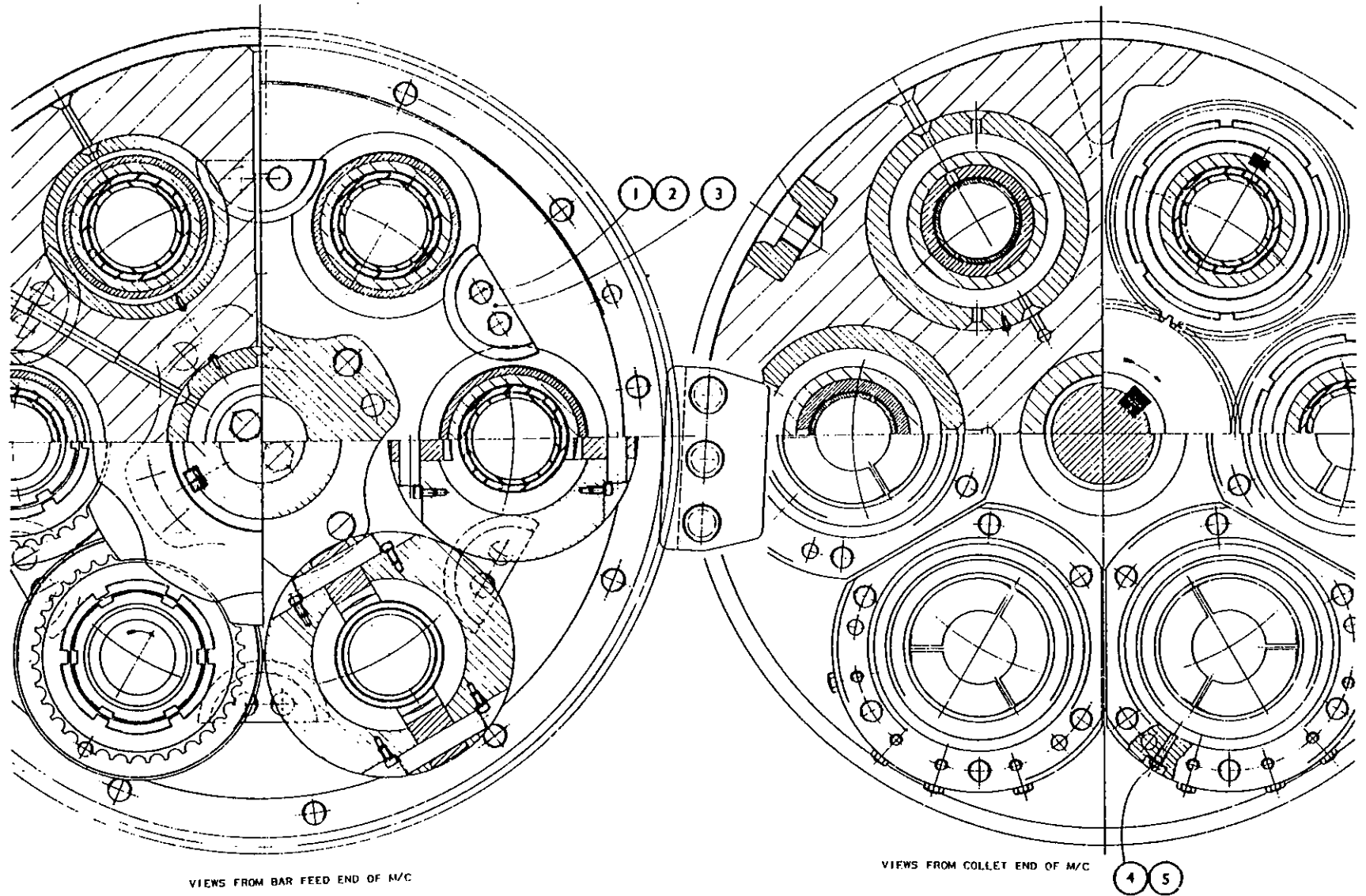

VIEWS FROM BAR FEED END OF M/C

VIEWS FROM COLLET END OF M/C

4 5

PLATE No. 2
Drawing No. 301 Z 2)

**WICKMAN
MULTI-SPINDLE
AUTOMATICS**

**SPINDLE ARRANGEMENT
6 $\frac{1}{8}$ "-6 AND 6 $\frac{1}{8}$ "-6D CHUCKING MACHINES**

INDEX NO.	PART NO.	TITLE.
1	301X.163	Thrust Block.
2	155/1248	$\frac{1}{2}$ " B.S.F. Socket Head Cap Screw, 3" long.
3	154/12	$\frac{1}{2}$ " Spring Washer.
4	155/0724	$\frac{1}{2}$ " B.S.F. Socket Head Cap Screw, 1 $\frac{1}{2}$ " long.
5	154/07	$\frac{1}{2}$ " Spring Washer.
6	141/14	$\frac{1}{2}$ " dia. Tapped Taper Pin, 2" long.
7	155/0828	$\frac{1}{2}$ " B.S.F. Socket Head Cap Screw, 1 $\frac{1}{2}$ " long.
8	154/08	$\frac{1}{2}$ " Spring Washer.
9	314Y.150	Centre Stem.
10	317X.144	Bolt.
11	198/16	$\frac{1}{2}$ " dia. Internal Shakeproof Washer.
12	—	Soft Iron Wire.
13	317X.145	Binding Plate.
14	151/65	22 T.P.I. Slotted Locknut, 65 mm.
15	176/0506	$\frac{1}{2}$ " B.S.F. Socket Head Set Screw, $\frac{3}{4}$ " long.
16	153/05	Soft Pad.
17	153/05	Soft Pad.
18	176/0506	$\frac{1}{2}$ " B.S.F. Socket Head Set Screw, $\frac{3}{4}$ " long.
19	151/50	22 T.P.I. Slotted Locknut, 50 mm.
20	303Y.245	Air Cylinder.
21	303V.224	Air Cylinder Adaptor.
22	130/07	$\frac{1}{4}$ " dia. Flat Washer.
23	203/07	$\frac{1}{4}$ " B.S.F. Simmonds Hexagon Locknut.
24	303V.210A	Clutch Operating Shaft.
25	303Z.109	Index Gear on Spindle Drum.
26	303V.121	Rear Bearing, End Cap.
27	S.B.40	Medium Roller Journal.
28	303X.120	Rear Bearing, Outer Spacer.
29	511X.172A	Lubricant Guide Bush.
30	104/50P	140 mm. Internal Circlip.
31	303V.112	Work Spindle Gear.
32	155/0412	$\frac{1}{2}$ " B.S.F. Socket Head Cap Screw, $\frac{3}{4}$ " long.
33	154/04	$\frac{1}{2}$ " Spring Washer.
34	303V.219	Driving Clutch Housing.
35	125/2220	$\frac{1}{4}$ " dia. Plain Taper Pin, 1 $\frac{1}{2}$ " long.
36	303X.214	Driving Clutch Plate Outer.
37	303X.212	Driving Clutch Plate Inner.

INDEX NO.	PART NO.	TITLE.
38	303X.213	Driving Clutch Plate Outer.
39	303X.209	Clutch Glut Spacer.
40	122/0828	Key.
41	303V.207	Clutch Fork.
42	303X.205	Clutch Centre Key.
43	159/408	4 B.A. Hexagon Countersunk Socket Head Screw, $\frac{1}{2}$ " long.
44	179/204	2 B.A. Hexagon Socket Set Screw, Cup Point, $\frac{1}{2}$ " long.
45	303X.227	Locknut.
46	153/42	Soft Pad.
47	303Y.206	Clutch Bobbin.
48	303X.197	Brake Inner Clutch Plate.
49	303X.198	Brake Outer Clutch Plate.
50	303X.226A	Drive Key.
51	303V.195	Brake Housing.
52	S.B.38	Light Angular Contact Ball Journal.
53	303V.117	Front Bearing, Outer Spacer.
54	143/0406D	$\frac{1}{2}$ " dia. Mills Grooved Pin, $\frac{3}{4}$ " long.
55	129/15	$\frac{1}{2}$ " Welch Plug.
56	212/04	$\frac{1}{2}$ " B.S.P. Autolub Nipple.
57	210/1725	Yellow Indicator Washer.
58	303V.114	Binding Cap for Spindle Front Bearings.
59	301X.116	Piston Ring.
60	303V.115	Ring Housing.
61	155/0736	$\frac{1}{4}$ " B.S.F. Socket Head Cap Screw, 2 $\frac{1}{2}$ " long.
62	303Z.102B	Work Spindle.
63	303X.196	Brake Thrust Plate.
64	308X.250	Clutch Spring Pin.
65	303X.220	Clutch Spring.
66	122/1220T	Key (Tapped).
67	303X.202	Thrust Ring.
68	—	Hardened Steel Ball, 13 mm.
69	303X.201	Clutch Adjusting Nut.
70	101/32	3 $\frac{1}{2}$ " dia. External Circlip.
71	303X.216A	Key for Driving Clutch.
72	303X.218	Clutch Drive Key.
73	S.B.39A	Extra Light Angular Contact, Ball Journal.
74	303X.222	Spindle Gear, Outer Spacer.
75	303X.221A	Spindle Gear, Inner Spacer.
76	102/42	4 $\frac{1}{2}$ " dia. Internal Circlip.

INDEX NO.	PART NO.	TITLE.
77	303X.123A	Rear Bearing Spacer.
78	303X.103	Draw Bar.
79	303X.124	Spacer, Rear Bearing.
80	121/1640T	Square Key (Tapped).
81	317X.149	Centre Bearing End Spacer.
82	143/0406D	$\frac{1}{2}$ " dia. Mills Grooved Pin, $\frac{3}{4}$ " long.
83	317X.153	Spacer.
84	303X.215	Driving Clutch Thrust Plate.
85	303V.211	Drive Clutch Thrust Plate.
86	308X.249	Clutch Spring Pin.
87	303V.217B	Driving Clutch Centre.
88	303V.203	Clutch Inner Member.
89	303X.200A	Key for Brake Clutch
90	303X.199	Brake Clutch Ring.
91	151/85	22 T.P.I. Slotted Locknut, 85 mm.
92	176/0506	$\frac{1}{2}$ " B.S.F. Socket Head Set Screw, $\frac{3}{4}$ " long.
93	153/05	Soft Pad.
94	303X.194	Spacer Front Bearing.
95	303X.159	Labyrinth Ring.
96	303Y.246	3 Jaw Air Chuck.
97	155/0628	$\frac{3}{4}$ " B.S.F. Socket Head Cap Screw, 1 $\frac{1}{2}$ " long.
98	154/06	$\frac{1}{2}$ " Spring Washer.
99	141/10	$\frac{1}{2}$ " Tapped Taper Pin, 2" long.
100	176/0506	$\frac{1}{2}$ " B.S.F. Socket Head Set Screw, $\frac{3}{4}$ " long.
101	153/05	Soft Pad.
102	301X.156	Stop Screw.
103	154/06	$\frac{1}{2}$ " Spring Washer.
104	155/0620	$\frac{3}{4}$ " B.S.F. Socket Head Cap Screw, 1 $\frac{1}{2}$ " long.
105	301X.146	Locator.
106	317X.154	Centre Bearing, Inner Spacer.
107	257/60	Medium Ball Journal, 60 x 130 x 31 mm.
108	303V.136	Centre Shaft Gear.
109	121/2056T	Tapped Key, $\frac{1}{2}$ " x $\frac{1}{2}$ " x 3 $\frac{1}{2}$ " long.
110	130/08	$\frac{1}{2}$ " dia. Flat Washer.
111	203/08L	$\frac{1}{2}$ " B.S.F. Self-Locking Nut (Thin).
112	317X.142	Threaded Taper Pin.
113	317Y.140	Centre Driving Shaft.
114	317Y.141	Centre Guide.
115	303Z.101	Spindle Drum.

List of Parts for
PLATE No. 3
(Drawing No. 303 Z 1)

WHEN ORDERING SPARE PARTS ALWAYS QUOTE THE SERIAL NUMBER OF THE MACHINE

SPINDLE ASSEMBLY
6 $\frac{5}{8}$ "-6 AND 6 $\frac{5}{8}$ "-6D CHUCKING MACHINES

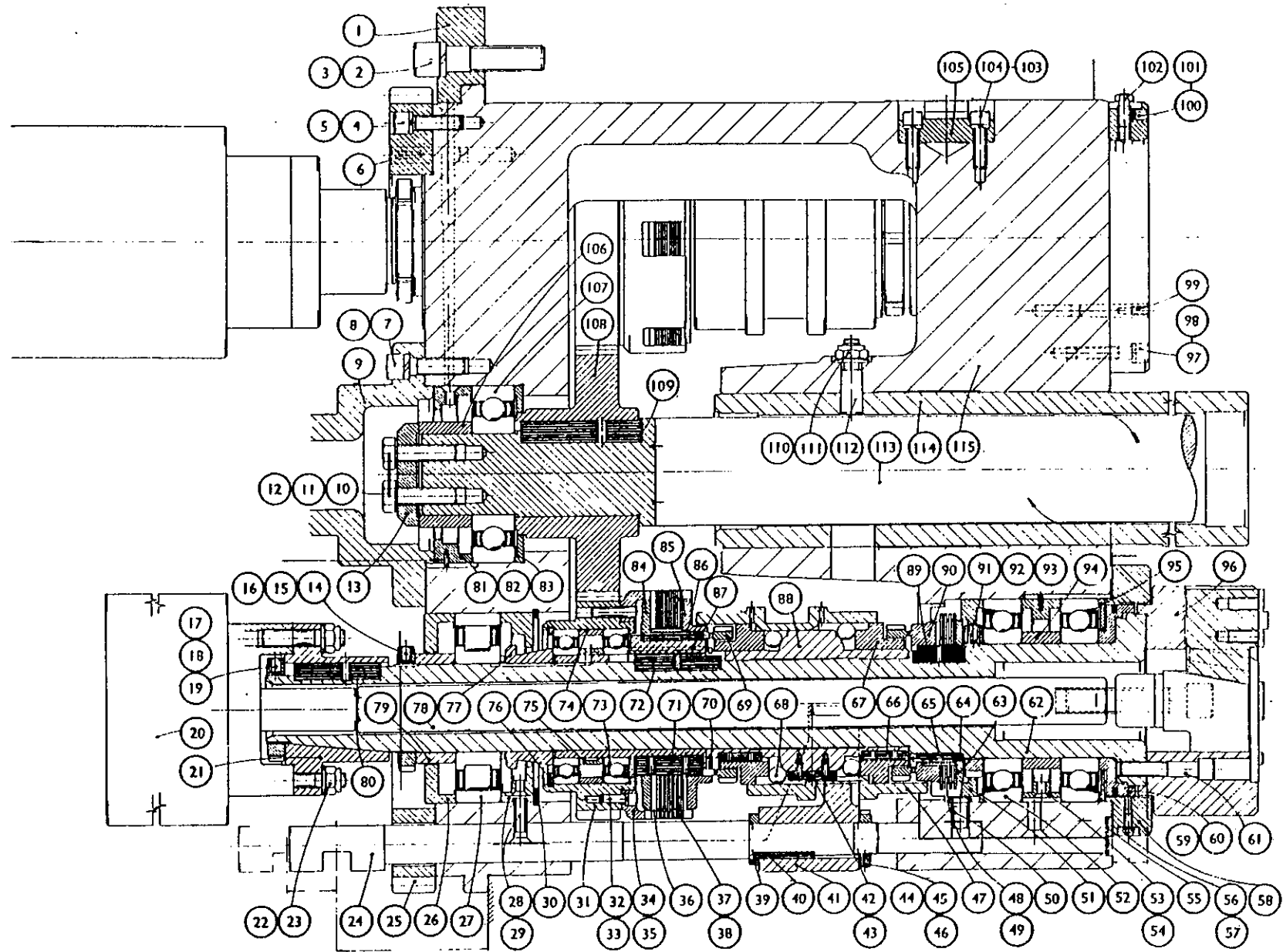

PLATE No. 3
(Drawing No. 303 Z 1)

**WICKMAN
MULTI-SPINDLE
AUTOMATICS**

303 Z 1B SPINDLE ARRANGEMENT

6 $\frac{1}{2}$ "-6 and 6 $\frac{1}{2}$ "-6D MACHINES

COMMENCING ON INSPECTION No. 14303. NOT USED ON INSPECTION No. 14699

INDEX NO.	PART NO.	TITLE	INDEX NO.	PART NO.	TITLE
1	141/14	Taper Pin, Tapped, 1/2" dia. x 2" long	30	303Y246	Chuck
2	154/07	Spring Washer, 7/16" dia.	31	303X202	Thrust Ring
3	155/0724	Socket Head Cap Screw, 7/16" B.S.F. x 1.1/2" long	32	122/1220T	Rectangular Key, Tapped, 3/8" x 1/4" x 1.1/4" long
4	154/12	Spring Washer, 3/4" dia.	33	303X220A	Clutch Spring
5	155/1248	Socket Head Cap Screw, 3/4" B.S.F. x 3/4" long	34	308X250	Clutch Spring Pin
6	301X163	Thrust Block	35	303X196	Brake Thrust Plate
7	301X146	Locator	36	303Z102C	Work Spindle
8	155/0620	Socket Head Cap Screw, 3/8" B.S.F. x 1.1/4" long	37	301X116	Piston Ring
9	154/06	Spring Washer, 3/8" dia.	38	303V1158	Ring Housing
10	301X156	Stop Screw	39	155/0736	Socket Head Cap Screw, 7/16" B.S.F. x 2.1/4" long
11	153/05	Soft Pad for 5/16" dia. Screw	40	303V1148	Binding Cap for Spindle Front Bearing.
12	176/0506	Socket Head Set Screw, 5/16" B.S.F. x 3/8" long	41	212/04	Autolub Nipple, 1/4" B.S.F.
13	141/10	Taper Pin, Tapped, 13/32" dia. x 2" long	42	210/1725	Yellow Indicator Washer for 1/4" B.S.F.
14	154/06	Spring Washer, 3/8" dia.	43	129/15	Welch Plug, 1.1/8" dia.
15	155/0628	Socket Head Cap Screw, 3/8" B.S.F. x 1.3/4" long	44	303X117A	Front Bearing, Outer Spacer
16	130/08	Flat Washer, 1/2" dia. (Section 317)	45	143/0406D	Grooved Pin, Type D, 1/8" dia. x 3/8" long
17	203/08L	Locknut, 1/2" B.S.F. (Section 317)	46	S8116	Heavy Duty Front Spindle Bearings
18	317X142	Taper Pin, Threaded, (Section 317)	47	303V195A	Brake Housing
19	317Y140A	Centre Driving Shaft (Section 317)	48	303X226A	Drive Key (for Brake)
20	317Y141D	Centre Guide (Section 317)	49	303X197	Brake Inner Clutch Plate
21	303Z101A	Spindle Drum	50	303X198	Brake Outer Clutch Plate
22	303X200A	Key for Brake Clutch	51	303Y206	Clutch Bobbin
23	303X199	Brake Clutch Ring	52	303X227	Locknut
24	303X144	Spindle Locknut	53	153/42	Soft Pad for 2 B.A. Screw
25	176/0506	Socket Head Set Screw, 5/16" B.S.F. x 3/8" long	54	179/204	Hexagon Socket Set Screw, Cup Point, 2 B.A. x 1/4" long
26	153/05	Soft Pad for 5/16" dia. Screw	55	303X205	Clutch Centre Key
27	303X194A	Spacer, Front Bearing	56	159/408	Hexagon Socket Countersunk Head Screw, 4 B.A. x 1/2" long
28	302X160	Labyrinth Ring	57	303V207	Clutch Fork
29	303X103	Draw Bar	58	122/0828	Rectangular Key, 1/4" x 3/16" x 1.3/4" long

Continued.....

List of Parts for
PLATE No. 3A
(Drawing No. 303Z1B)

WHEN ORDERING SPARE PARTS ALWAYS QUOTE THE INSPECTION NUMBER OF THE MACHINE

**WICKMAN
MULTI-SPINDLE
AUTOMATICS**

303 Z 1B SPINDLE ARRANGEMENT

6 $\frac{1}{4}$ "-6 and 6 $\frac{1}{4}$ "-6D MACHINES

COMMENCING ON INSPECTION No. 14303. NOT USED ON INSPECTION No. 14699

**Obsolete
Last Used On
M/c No.16355**

INDEX NO.	PART NO.	TITLE	INDEX NO.	PART NO.	TITLE
59	303X209	Clutch Glut Spacer	89	S851	Roller and Ball Journal, Extra Light
60	303X212	Driving Clutch Plate, Inner	90	303X218	Clutch Drive Key
61	303X213	Driving Clutch Plate, Outer	91	303X216A	Key for Driving Clutch
62	303X214	Driving Clutch Plate, Outer	92	101/32	External Circlip for 3.1/8" dia.
63	303V219	Driving Clutch Housing	93	303X201	Clutch Adjusting Nut
64	125/2220	Taper Pin, Plain, 11/32" dia. x 1.1/4" long	94	-	Hardened Steel Ball, 13 mm dia.
65	155/0412	Socket Head Cap Screw, 1/4" B.S.F. x 3/4" long	95	303V203	Clutch Inner Member
66	184/04	Spring Washer, 1/4" dia.	96	303V217E	Driving Clutch Centre
67	303V112	Work Spindle Gear	97	308X249	Clutch Spring Pin
68	104/5P	Internal Circlip, 140 mm	98	303V211	Drive Clutch Thrust Plate
69	303X120	Rear Bearing, Outer Spacer	99	303X215	Driving Clutch Thrust Plate
70	511X172A	Lubricant Guide Bush	100	317X157	Spacer (Section 317)
71	SB40	Roller Journal, Medium	101	143/0406D	Mills Pin, 1/8" dia. x 3/8" long (Section 317)
72	303V121	Rear Bearing, End Cap	102	317V156	Centre Bearing, Outer Spacer (Section 317)
73	303Z109	Index Gear on Spindle Drum	103	317X145	Binding Plate (Section 317)
74	303V210B	Clutch Operating Shaft	104	151/65	Slotted Locknut, 65 mm, 22 T.P.I.
75	203/07	Selflocking Nut, 7/16" B.S.F.	105	176/0506	Socket Head Set Screw, 5/16" dia. x 3/8" long
76	130/07	Plain Washer for 7/16" dia.	106	153/05	Soft Pad for 5/16" dia. Screw
77	303V224	Air Cylinder Adaptor	107	-	Soft Iron Wire (Section 317)
78	303Y245	Air Cylinder	108	198/16	Shakeproof Lockwasher, 1/2" dia. (Section 317)
79	151/50	Slotted Locknut, 5 mm, 22 T.P.I.	109	317X144	Bolt (Section 317)
80	176/0506	Socket Head Set Screw, 5/16" B.S.F. x 3/8" long	110	317X155	Centre Bearing, Inner Spacer (Section 317)
81	153/05	Soft Pad for 5/16" dia. Screw	111	314Y150	Centre Stem
82	121/1640T	Square Key, Tapped, 1/2" x 1/2" x 2.1/2" long	112	154/08	Spring Washer, 1/2" dia.
83	303X124	Spacer, Rear Bearing	113	155/0828	Socket Head Cap Screw, 1/2" B.S.F. x 1.3/4" long
84	303X123B	Rear Bearing Spacer	114	317X158	Bearing Housing (Section 317)
85	303X228	Oil Retainer	115	269/60	Ball Journal, Light Type, Metric. 60 mm x 110 mm x 1.7/16" (Section 317)
86	102 42	Internal Circlip for 4.1/2" dia.	116	303V136A	Centre Shaft Gear
87	303X221B	Spindle Gear, Inner Spacer	117	121/2056T	Square Key, 5/8" x 5/8" x 3.1/2" long (Section 317)
88	303X222A	Spindle Gear, Outer Spacer			

**List of Parts for
PLATE No. 3A
(Drawing No. 303Z1B)**

WHEN ORDERING SPARE PARTS ALWAYS QUOTE THE INSPECTION NUMBER OF THE MACHINE

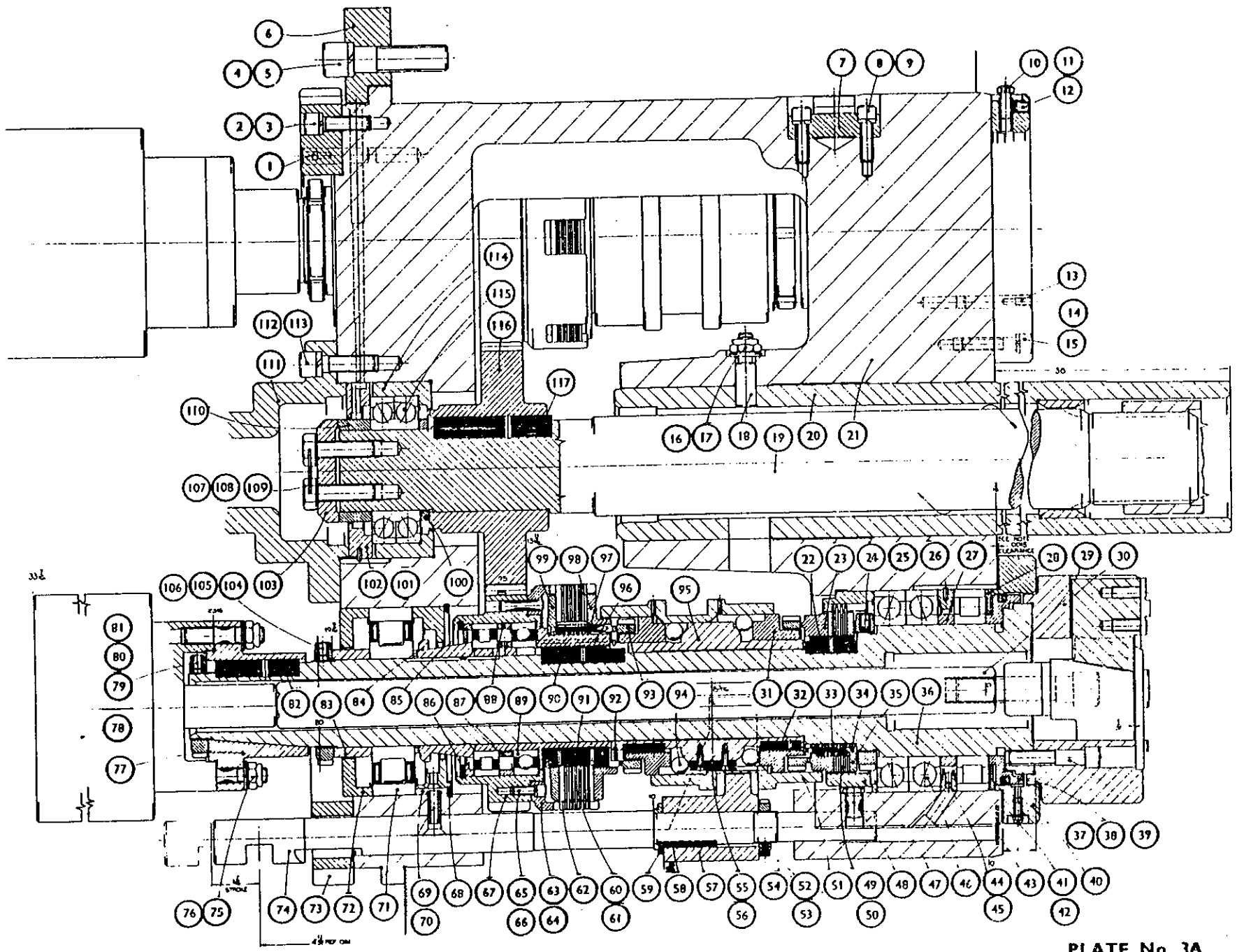

PLATE No. 3A
 (Drawing No. 303 Z 1B)

Handwritten text, likely bleed-through from the reverse side of the page.

303 Z 1C SPINDLE ARRANGEMENT

6 1/4"-6 and 6 1/4"-6D MACHINES

COMMENCING ON INSPECTION No. 16358

INDEX NO.	PART NO.	TITLE	INDEX NO.	PART NO.	TITLE
1	141/14	Taper Pin, Tapped, 1/2" dia. x 2" long	30	303Y246	Chuck
2	154/07	Spring Washer, 7/16" dia.	31	303X202	Thrust Ring
3	155/0724	Socket Head Cap Screw, 7/16" B.S.F. x 1.1/2" long	32	122/1220T	Rectangular Key, Tapped, 3/8" x 1/4" x 1.1/4" long
4	154/12	Spring Washer, 3/4" dia.	33	303X220A	Clutch Spring
5	155/1248	Socket Head Cap Screw, 3/4" B.S.F. x 3/4" long	34	308X250	Clutch Spring Pin
6	301X163	Thrust Block	35	303X196	Brake Thrust Plate
7	301X146	Locator	36	303Z102C	Work Spindle
8	155/0620	Socket Head Cap Screw, 3/8" B.S.F. x 1.1/4" long	37	301X116	Piston Ring
9	154/06	Spring Washer, 3/8" dia.	38	303V115B	Ring Housing
10	301X156	Stop Screw	39	155/0736	Socket Head Cap Screw, 7/16" B.S.F. x 2.1/4" long
11	153/05	Soft Pad for 5/8" dia. Screw	40	303V114B	Binding Cap for Spindle Front Bearing
12	176/0506	Socket Head Set Screw, 5/16" B.S.F. x 3/8" long	41	212/04	Autofub Nipple, 1/4" B.S.F.
13	141/10	Taper Pin, Tapped, 13/32" dia. x 2" long	42	210/1725	Yellow Indicator Washer for 1/4" B.S.F.
14	154/06	Spring Washer, 3/8" dia.	43	129/15	Welch Plug, 1.1/8" dia.
15	155/0628	Socket Head Cap Screw, 3/8" B.S.F. x 1.3/4" long	44	303X117A	Front Bearing, Outer Spacer
16	130/08	Flat Washer, 1/2" dia.	45	143/0406D	Grooved Pin, Type D, 1/8" dia. x 3/8" long
17	203/08L	Locknut, 1/2" B.S.F.	46	SB116	Heavy Duty Front Spindle Bearings
18	317X142	Taper Pin, Threaded	47	303V195A	Brake Housing
19	317Y140A	Centre Driving Shaft	48	303X226A	Drive Key (for Brake)
20	317Y141D	Centre Guide	49	303X197	Brake Inner Clutch Plate
21	303Z101A	Spindle Drum	50	303X198	Brake Outer Clutch Plate
22	303X200A	Key for Brake Clutch	51	303Y206	Clutch Bobbin
23	303X199	Brake Clutch Ring	52	303X227	Locknut
24	303X144	Spindle Locknut	53	153/42	Soft Pad for 2BA Screw
25	176/0506	Socket Head Set Screw, 5/16" B.S.F. x 3/8" long	54	179/204	Hexagon Socket Set Screw, Cup Point, 2B.A. x 1/4" long
26	153/05	Soft Pad for 5/16" dia. Screw	55	303X205	Clutch Centre Key
27	303X194A	Spacer, Front Bearing	56	159/408	Hexagon Socket Countersunk Head Screw, 4 B.A. x 1/2" long
28	302X160	Labyrinth Ring	57	303V207	Clutch Fork
29	303X103	Draw Bar	58	122/0828	Rectangular Key, 1/4" x 3/16" x 1.3/4" long

Continued.....

List of Parts for
PLATE No.38
 (Drawing No. 303Z1C)

WHEN ORDERING SPARE PARTS ALWAYS QUOTE THE INSPECTION NUMBER OF THE MACHINE

303 Z 1C SPINDLE ARRANGEMENT

6 1/2" - 6 and 6 1/2" - 6D MACHINES

COMMENCING ON INSPECTION No. 16358

INDEX NO.	PART NO.	TITLE	INDEX NO.	PART NO.	TITLE
59	303X209	Clutch Glut Spacer	89	SB120	Roller and Ball Journal, Extra Light
60	303X212	Driving Clutch Plate, Inner	90	303X218	Clutch Drive Key
61	303X213	Driving Clutch Plate, Outer	91	303X216A	Key for Driving Clutch
62	303X214	Driving Clutch Plate, Outer	92	101/32	External Circlip for 3.1/8" dia.
63	303V219	Driving Clutch Housing	93	303X201	Clutch Adjusting Nut
64	125/2220	Taper Pin, Plain, 11/32" dia. x 1.1/4" long	94	--	Hardened Steel Ball, 13mm dia.
65	155/0412	Socket Head Cap Screw, 1/4" B.S.F. x 3/4" long	95	303V203	Clutch Inner Member
66	154/04	Spring Washer, 1/4" dia.	96	303V217F	Driving Clutch Centre
67	303V112C	Work Spindle Gear	97	308X249	Clutch Spring Pin
68	104/50P	Internal Circlip, 140mm	98	303V211	Drive Clutch Thrust Plate
69	303X120	Rear Bearing, Outer Spacer	99	303X215	Driving Clutch Thrust Plate
70	511X172A	Lubricant Guide Bush	100	317X157	Spacer
71	SB40	Roller Journal, Medium	101	143/0406D	Mills Pin, 1/8" dia. x 3/8" long
72	303V121	Rear Bearing, End Cap	102	317V156	Centre Bearing, Outer Spacer
73	303Z109	Index Gear on Spindle Drum	103	317X145	Binding Plate (Section 317)
74	303V210B	Clutch Operating Shaft	104	151/65	Slotted Locknut, 65mm, 22 T.P.I.
75	203/07	Selflocking Nut, 7/16" B.S.F.	105	176/0506	Socket Head Set Screw, 5/16" dia. x 3/8" long
76	130/07	Plain Washer for 7/16" dia.	106	153/05	Soft Pad for 5/16" dia. Screw
77	303V224	Air Cylinder Adaptor	107	--	Soft Iron Wire
78	303Y245	Air Cylinder	108	198/16	Shakeproof Lockwasher, 1/2" dia.
79	151/50	Slotted Locknut, 5mm, 22 T.P.I.	109	317X144	Bolt (Section 317)
80	176/0506	Socket Head Set Screw, 5/16" B.S.F. x 3/8" long	110	317X155	Centre Bearing, Inner Spacer
81	153/05	Soft Pad for 5/16" dia. Screw	111	314Y150	Centre Stem
82	121/1640T	Square Key, Tapped, 1/2" x 1/2" x 2.1/2" long	112	154/08	Spring Washer, 1/2" dia.
83	303X124	Spacer, Rear Bearing	113	155/0828	Socket Head Cap Screw, 1/2" B.S.F. x 1.3/4" long
84	303X123B	Rear Bearing Spacer	114	317X158	Bearing Housing
85	303X228A	Oil Retainer	115	269/60	Ball Journal, Light Type, Metric, 60mm x 110mm x 1.7/16"
86	104/45	Internal Circlip for 115mm dia.	116	303V136A	Centre Shaft Gear
87	303X221C	Spindle Gear, Inner Spacer	117	121/2056T	Square Key, 5/8" x 5/8" x 3.1/2" long
88	303X222B	Spindle Gear, Outer Spacer			

List of Parts for
PLATE No.3B
 (Drawing No.303Z1C)

WHEN ORDERING SPARE PARTS ALWAYS QUOTE THE INSPECTION NUMBER OF THE MACHINE

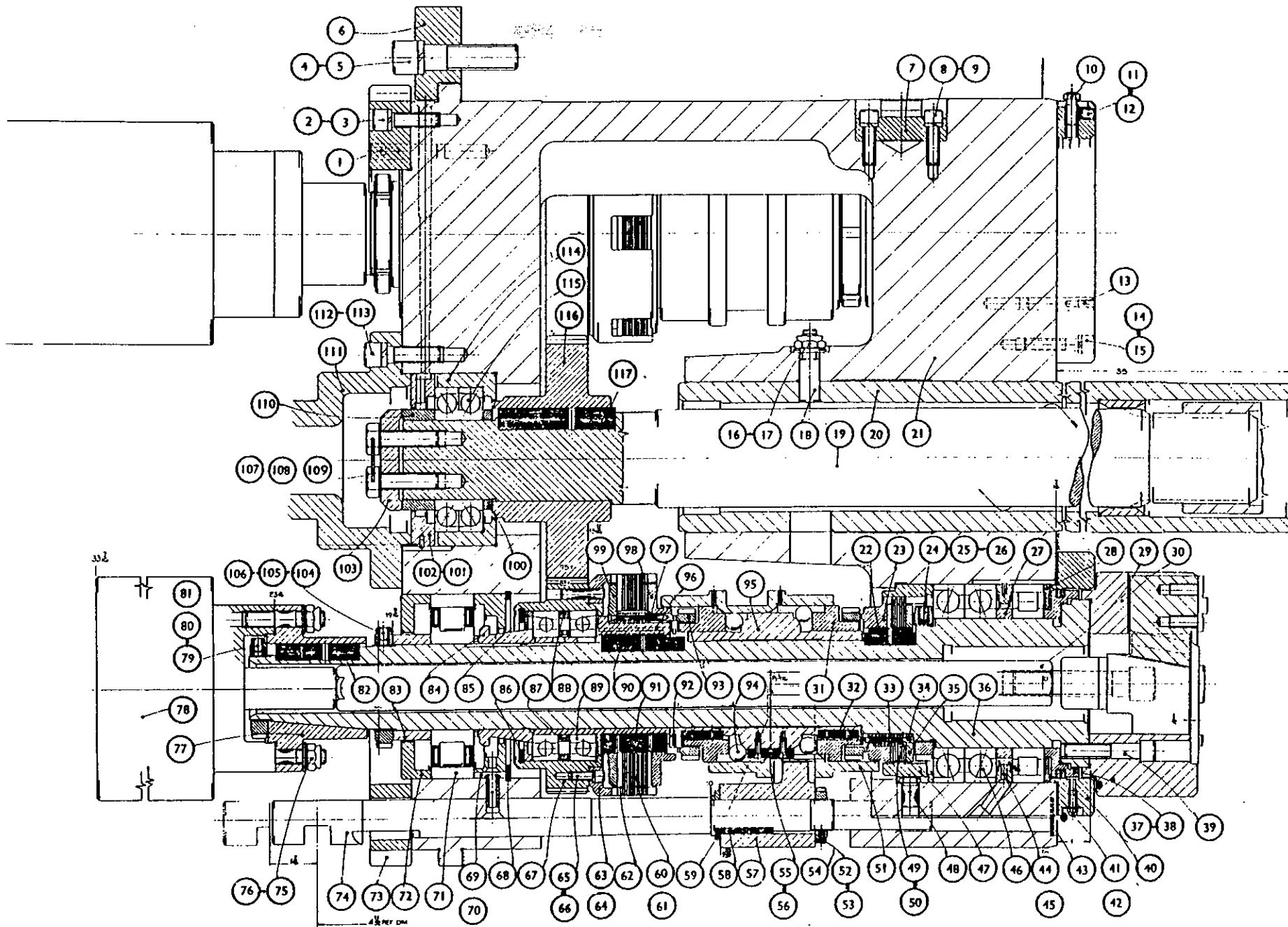

SPINDLE ARRANGEMENT
 6 1/4" - 6 AND 6 1/2" - 6D MACHINES

PLATE No.3B
 (Drawing No.30321C)

**WICKMAN
MULTI-SPINDLE
AUTOMATICS**

**SPINDLE ARRANGEMENT
6 $\frac{5}{8}$ "-6 AND 6 $\frac{5}{8}$ "-6D CHUCKING MACHINES**

INDEX NO.	PART NO.	TITLE.
1	301X.180	Clamp for Rear Bearing Cap.
2	155/0720	$\frac{1}{4}$ " B.S.F. Socket Head Cap Screw, 1 $\frac{1}{2}$ " long.
3	154/07	$\frac{7}{16}$ " Spring Washer.

List of Parts for
PLATE No. 4
(Drawing No. 303 Z 2)

WHEN ORDERING SPARE PARTS ALWAYS QUOTE THE SERIAL NUMBER OF THE MACHINE

SPINDLE ASSEMBLY

6 $\frac{5}{8}$ "-6 AND 6 $\frac{5}{8}$ "-6D CHUCKING MACHINES

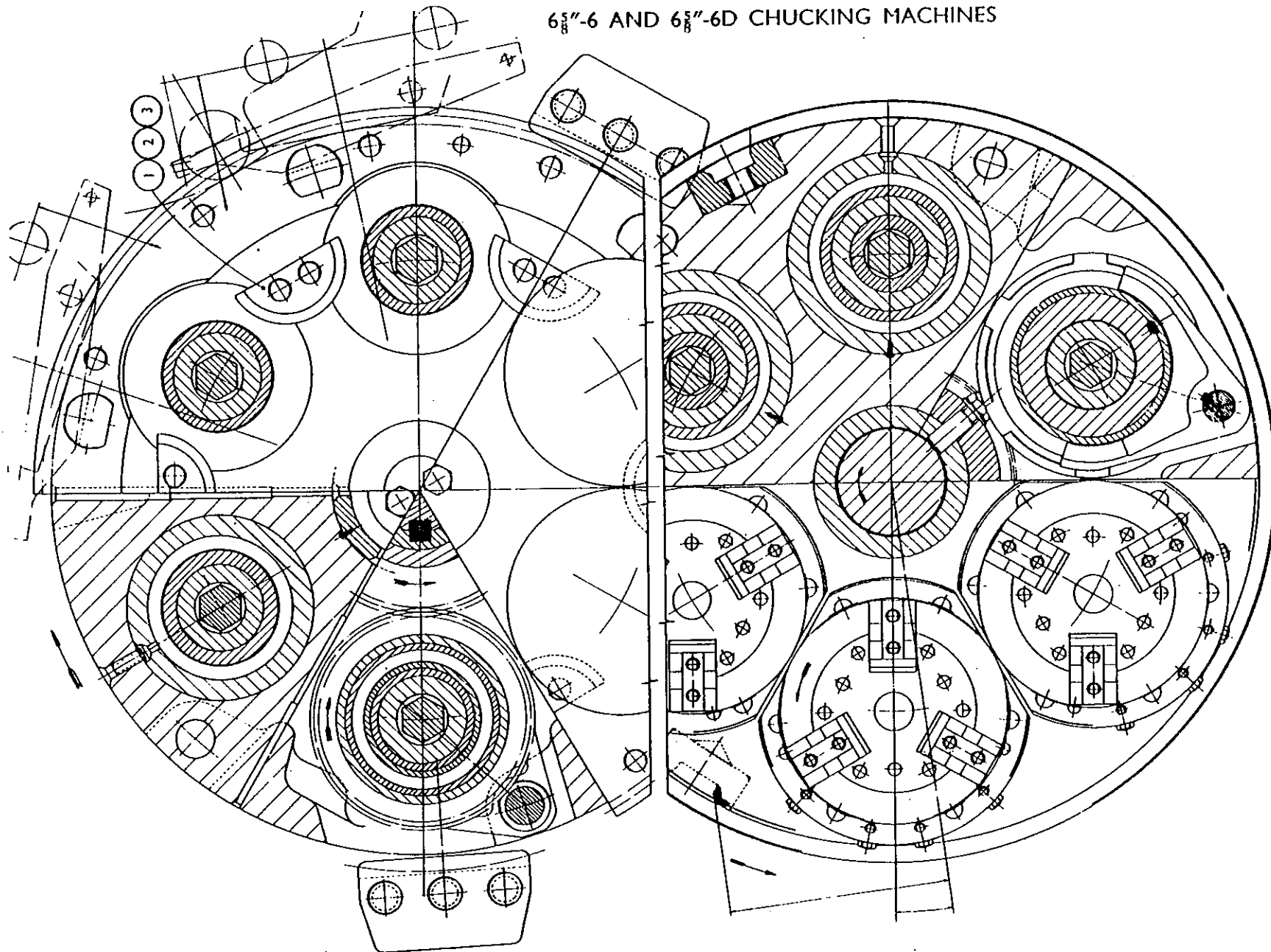

PLATE No. 4
(Drawing No. 303 Z 2)

**WICKMAN
MULTI-SPINDLE
AUTOMATICS**

SPINDLE STOPPING UNIT

6 3/8" -6 AND 6 3/8" -6D CHUCKING MACHINES

INDEX NO.	PART NO.	TITLE	INDEX NO.	PART NO.	TITLE
1	304V.119	Cranked Shaft	31	212/18	1/8" B.S.P. Autolub Nipple
2	167/0614	3/8" B.S.F. Hex. Head Set Screw, 7/8" long	32	210/1725	Yellow Indicator Washer
3	197/12	3/8" dia. Shakeproof Lockwasher	33	-	Torrington Needle Roller Bearing. B1212
4	183/0632	3/8" B.S.F. Square Head Set Screw, Taper Point 2" long	34	101/6	External Circlip, 3/4" dia.
5			35	304X.123	Gear
5	173/06	3/8" B.S.F. Hexagon Locknut	36	304X.122	Operating Rack
6	304V.113A 304V.114	6 3/8" - only) 6 3/8" -6D only) Right-hand Switch Bracket	37	304X.132	Stop Housing
7	141/3	11/32" dia. Taper Pin (Tapped), 1 1/4" long	38	178/0636	3/8" B.S.F. Socket Set Screw, Dog Point, 2 1/4" long
8	-	" Snap-lock " Limit Switch, Series 16D.1200	39	173/06L	3/8" B.S.F. Locknut
9	304V.111A	Left-hand Bracket	40	173/06	3/8" B.S.F. Hexagon Nut
10	167/0610	5/16" B.S.F. Hex. Head Set Screw, 3/4" long	41	304X.110	Washer
11	130/06	5/16" dia. Flat Washer	42	304X.124	Shoe Spring
12	212/9018	3/8" B.S.P. Autolub Nipple (Angled).	43	304X.109	Eye Bolt
13	210/2526	Yellow Indicator Washer	44	304X.126	Spring Pin
14	155/0414	1/4" B.S.F. Socket Head Cap Screw, 7/8" long	45	127/0405	1/16" dia. Cotter Pin, 3/8" long
15	154/04	1/4" Spring Washer	46	236/202424	Oil Retaining Bush
16	173/07L	7/16" B.S.F. Locknut	47	304X.128	Slide Guide
17	212/9018	3/8" B.S.P. Autolub Nipple (Angled)	48	155/0614	5/16" B.S.F. Socket Head Cap Screw, 7/8" long
18	210/2526	Yellow Indicator Washer	49	154/06	5/16" Spring Washer
19	173/06L	3/8" B.S.F. Locknut	50	304X.127	Glut Pin
20	183/0624	3/8" B.S.F. Square Head Screw, Taper Point, 1 1/2" long	51	127/0405	1/16" dia. Cotter Pin, 1" long
21	176/0614	5/16" B.S.F. Socket Set Screw, 7/8" long	52	304X.120	Operating Pad
22	153/06	Soft Pad.	53	-	Torrington Needle Roller Bearing. B1212
23	155/0612	5/16" B.S.F. Socket Head Cap Screw, 3/4" long	54	304X.121	Roller
24	154/06	5/16" Spring Washer	55	141/3	11/32" dia. Taper Pin (Tapped), 1 1/4" long
25	304Z.101U	Housing	56	304X.117	Clutch Shoe
26	-	Torrington Needle Roller Bearing, B1B12	57	236/202424	Oil Retaining Bush
27	121/0820T	1/4" Square Key (Tapped), 1 1/2" long	58	304X.128	Slide Guide
28	304X.125	Bearing Housing	59	304Y.102	6 3/8" -6 only) 6 3/8" -6D only) Slide
29	155/0410	1/4" B.S.F. Socket Head Cap Screw, 3/4" long	60	304V.134	Maxam Air Cylinder, C3, DF, 4" stroke
30	154/04	1/4" Spring Washer			

List of Parts for
PLATE No.6
(Drawing No.304 Z 1)

WHEN ORDERING SPARE PARTS ALWAYS QUOTE THE SERIAL NUMBER OF THE MACHINE

SPINDLE STOPPING UNIT
6 $\frac{3}{8}$ "-6 AND 6 $\frac{3}{8}$ "-6D CHUCKING MACHINES

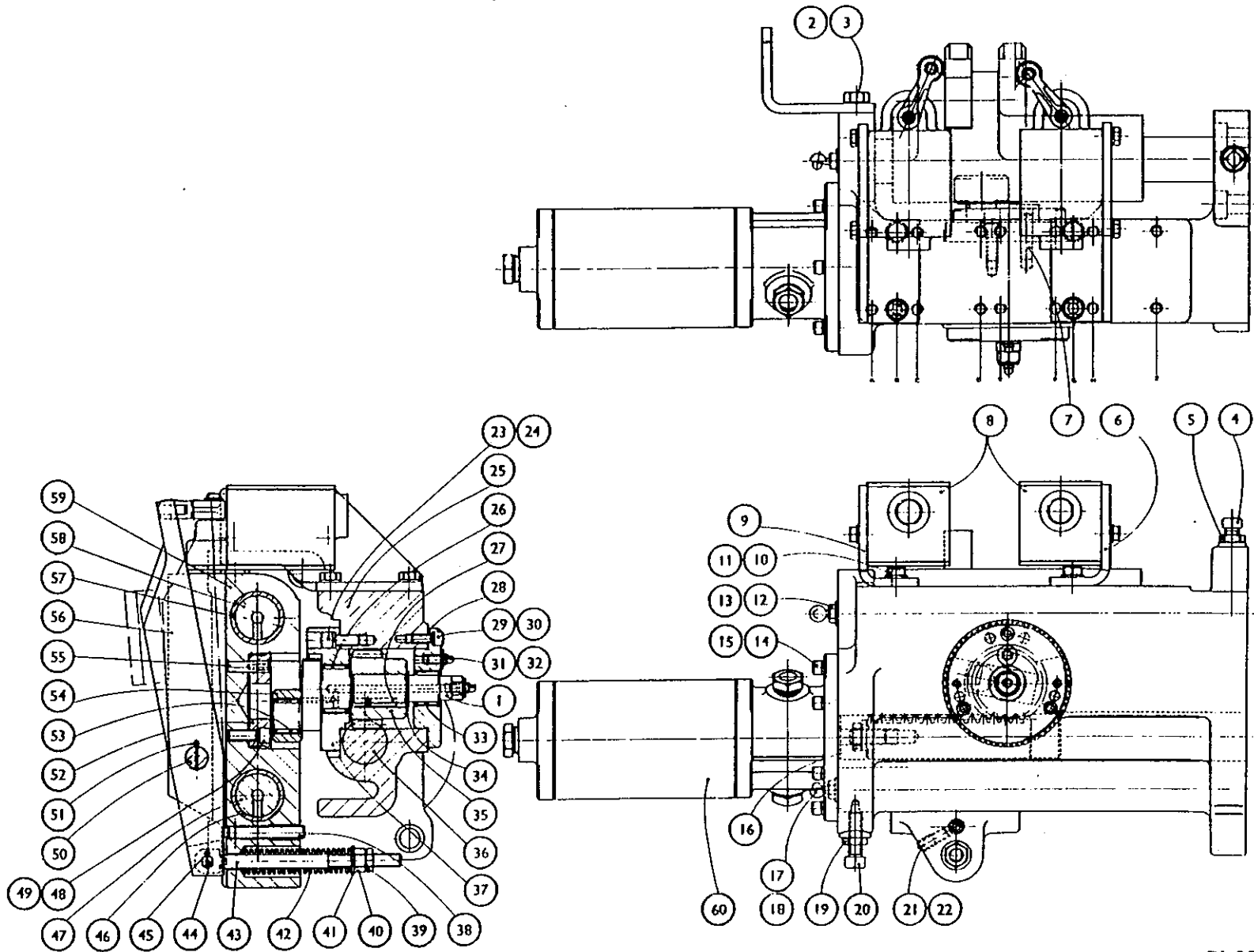

PLATE No. 5
(Drawing No. 304 Z 1)

**WICKMAN
MULTI-SPINDLE
AUTOMATICS**

**CLUTCH ADJUSTING UNIT
6 $\frac{5}{8}$ "-6 CHUCKING MACHINE**

INDEX NO.	PART NO.	TITLE.	INDEX NO.	PART NO.	TITLE.
1	155/0740	$\frac{3}{16}$ " B.S.F. Socket Head Cap Screw, 2 $\frac{1}{2}$ " long.	15	182/0414	$\frac{1}{2}$ " B.S.F. Socket Set Screw, Taper Point, $\frac{1}{2}$ " long.
2	154/07	$\frac{3}{16}$ " Spring Washer.	16	504X.152	Anchor Pin.
3	155/0740	$\frac{3}{16}$ " B.S.F. Socket Head Cap Screw, 2 $\frac{1}{2}$ " long.	17	304X.163	Plunger.
4	154/07	$\frac{3}{16}$ " Spring Washer.	18	MSC183	Spring.
5	167/0410	$\frac{1}{2}$ " B.S.F. Hex. Head Set Screw, $\frac{1}{2}$ " long.	19	203/05L	$\frac{5}{16}$ " B.S.F. Pinnacle Nut.
6	198/8	$\frac{1}{2}$ " Shakeproof Washer.	20	167/0520	$\frac{1}{16}$ " B.S.F. Hex. Head Set Screw, 1 $\frac{1}{2}$ " long.
7	304Y.161	Bracket.	21	16D/1200	"Snap-Lock" Limit Switch.
8	101/11	External Circlip, 1".	22	304X.164	Switch Plate.
9	176/0714	$\frac{1}{16}$ " B.S.F. Socket Set Screw, Cup Point, $\frac{1}{2}$ " long.	23	203/06	$\frac{3}{16}$ " B.S.F. Pinnacle Nut.
10	126/1626	$\frac{1}{2}$ " dia. Parallel Dowel, 1 $\frac{1}{2}$ " long.	24	188/0636	$\frac{3}{8}$ " B.S.F. Square Head Set Screw, 2 $\frac{1}{2}$ " long.
11	304V.162	Lever.	25	176/0412	$\frac{1}{2}$ " B.S.F. Socket Set Screw, Cup Point, $\frac{1}{2}$ " long.
12	126/2040	$\frac{3}{8}$ " dia. Parallel Dowel, 2 $\frac{1}{2}$ " long.	26	153/04	Soft Pad.
13	504X.154	Pivot Pin.	27	556X.111A	Plunger.
14	203/04	$\frac{1}{2}$ " B.S.F. Pinnacle Nut.	28	144X.129	Clutch Spring.

List of Parts for
PLATE No. 6
(Drawing No. 304 Z 6)

WHEN ORDERING SPARE PARTS ALWAYS QUOTE THE SERIAL NUMBER OF THE MACHINE

CLUTCH ADJUSTING UNIT

6 $\frac{5}{8}$ "-6 CHUCKING MACHINE

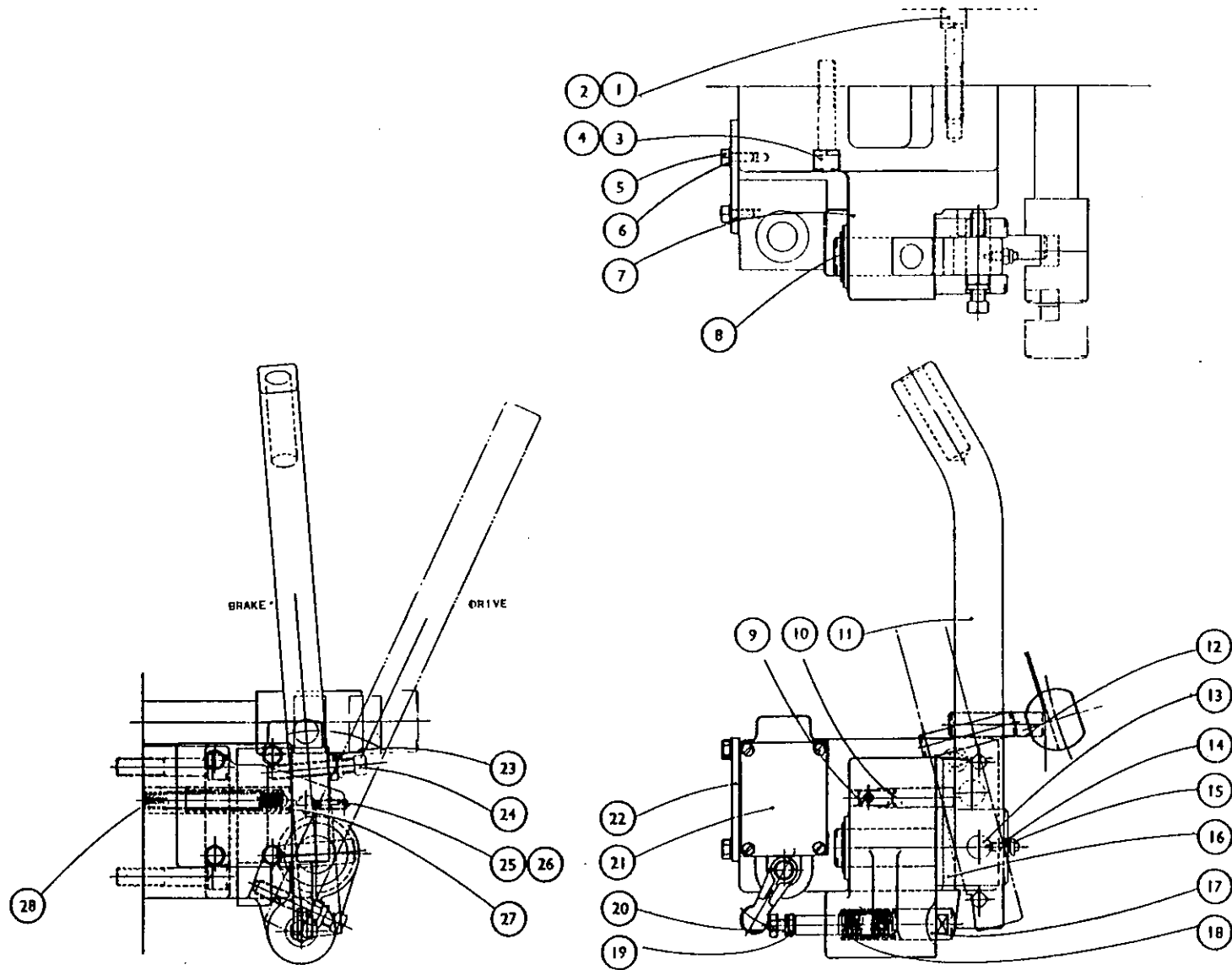

PLATE No. 6
(Drawing No. 304 Z 6)

INDEX NO.	PART NO.	TITLE	INDEX NO.	PART NO.	TITLE
1	154/05	$\frac{1}{16}$ " Spring Washer.	35	214V.172	Base.
2	155/0528	$\frac{1}{16}$ " B.S.F. Socket Head Cap Screw $1\frac{1}{2}$ " long.	36	237/81	Solid Elbow $\frac{1}{2}$ " Conduit.
3	314Z.110A	End Bracket.	37	237/301	Nipple $\frac{1}{2}$ " Conduit.
4	237/302	$\frac{1}{2}$ " Conduit Nipple.	38		$\frac{1}{2}$ " Soft Washer.
5	C.6492	$\frac{1}{2}$ " Lead Washer.	39	Type M.C.	Superflexit $\frac{1}{2}$ " Conduit 5' long.
6	237/82	Solid Elbow $\frac{1}{2}$ " Conduit.	40		$\frac{1}{2}$ " Soft Washer.
7	C.6493	$\frac{1}{2}$ " Lead Washer.	41	237/81	Solid Elbow $\frac{1}{2}$ " Conduit.
8	C.6492	$\frac{1}{2}$ " Lead Washer.	42	237/272	Hexagon Head Plug.
9	237/1210	Reducer $\frac{1}{2}$ " — $\frac{1}{2}$ " Conduit.	43	C.6492	$\frac{1}{2}$ " Lead Washer.
10	Superflexit Ref. 2	Type M.C. $\frac{1}{2}$ " conduit 21' long.	44	Ref. 2	Superflexit Type M.C. $\frac{1}{2}$ " x 12' long.
11	155/0510	$\frac{1}{16}$ " B.S.F. Socket Head Cap Screw $\frac{1}{2}$ " long.	45	C.6492	$\frac{1}{2}$ " Lead Washer.
12	514X.130	Cover Guide.	46	237/1210	Reducer $\frac{1}{2}$ " — $\frac{1}{2}$ " Conduit.
13	154/04	$\frac{1}{2}$ " dia. Spring Washer.	47	C.6493	$\frac{1}{2}$ " Lead Washer.
14	155/0428	$\frac{1}{2}$ " B.S.F. Socket Head Cap Screw $1\frac{1}{2}$ " long.	48	16D.1200	B.S.A. Snap Lock Limit Switch.
15	514X.198	Pressure Switch.	49	514V.124	Switch Bracket.
16	Size 00	Jubilee Hose Clip.	50	155/0510	$\frac{1}{16}$ " B.S.F. Socket Head Cap Screw $\frac{1}{2}$ " long.
17	572X.137	Instruction Plate.	51	514X.117	Switch Cam.
18	572X.139	Instruction Plate.	52	176/0608	$\frac{1}{2}$ " B.S.F. Socket Set Screw $\frac{1}{2}$ " long.
19	572X.138	Instruction Plate.	53	182/0612	$\frac{1}{2}$ " B.S.F. Taper Point Screw $\frac{3}{4}$ " long.
20	Size 1	Terminal Block 30 amp 6 way.	54	101/26	External Circlip 2 $\frac{1}{2}$ "
21	156/210	2 B.A. Socket Head Cap Screw $\frac{1}{2}$ " long.	55	155/0536	$\frac{1}{16}$ " B.S.F. Socket Head Cap Screw 2 $\frac{1}{2}$ " long.
22	572X.129A	Instruction Plate.	56	237/1210	Reducer $\frac{1}{2}$ " — $\frac{1}{2}$ " Conduit.
23	572X.130A	Instruction Plate.	57	C.6493	$\frac{1}{2}$ " Lead Washer.
24	DAS.185/10	Pipe Clip $\frac{1}{2}$ "	58	237/302	Nipple $\frac{1}{2}$ " Conduit.
25	156/210	2 B.A. Socket Head Cap Screw $\frac{1}{2}$ " long.	59	237/102	Short Arm Elbow $\frac{1}{2}$ " Conduit.
26	237/354	Entry Bush 1" Conduit.	60	Ref. 2	Superflexit Type M.C. $\frac{1}{2}$ " x 16' long.
27	C.6495	Lear Washer.	61	C.6492	$\frac{1}{2}$ " Lead Washer.
28	143/1232D	Groove d Pin $\frac{1}{8}$ " dia. x 2" long.	62	514V.196	Terminal Block.
29	514Y.193	Solenoid Operated Valve.	63	155/0410	$\frac{1}{2}$ " B.S.F. Socket Head Cap Screw. $\frac{1}{2}$ " long.
30	155/0732	$\frac{1}{16}$ " B.S.F. Socket Head Cap Screw 2" long.	64	154/04	$\frac{1}{2}$ " Spring Washer.
31	154/07	$\frac{1}{16}$ " Spring Washer.	65	237/351	Entry Bush $\frac{1}{2}$ " Conduit.
32	155/0424	$\frac{1}{2}$ " B.S.F. Socket Head Cap Screw $1\frac{1}{2}$ " long.	66	572X.132A	Instruction Plate.
33	154/04	$\frac{1}{16}$ " Spring Washer.	67	572X.131A	Instruction Plate.
34	514X.518	Adaptor (fitted to Canadian and American Machines Only).			

END BRACKET AND CONTROL UNIT ASSEMBLY

6 $\frac{1}{2}$ "—6, 6 $\frac{1}{2}$ "—6D, CHUCKING MACHINES

Commencing
M/c No. 9546

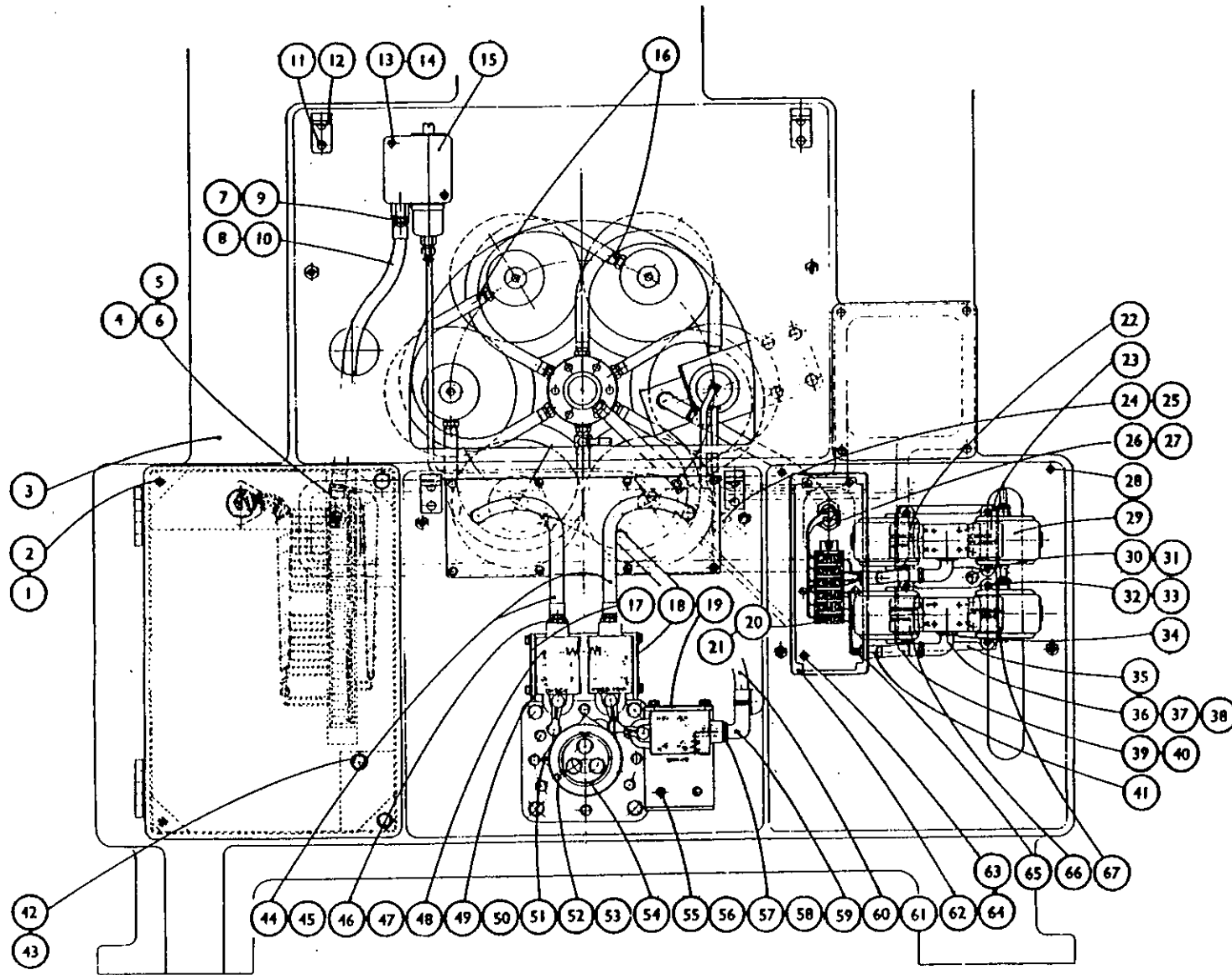

PLATE No. 7
(Drawing No. 314Z4A)

314 Z 4B END BRACKET & CONTROL UNIT ASSEMBLY
6 1/2" - 6 AIR CHUCKER. SECTION 314

Last used on
 machine No.15093

INDEX NO.	PART NO.	TITLE	INDEX NO.	PART NO.	TITLE
1	247/1021	3/4" Dia. Conduit 21" long	35	--	3/16" Whit. Screw 7/16" long
2	357/10	3/8" Soft Washer	36	--	TAL Blanking Plate GP 10
3	237/1210	3/4"-5/8" Reducer	37	154/05	5/16" Spring Washer
4	357/12	3/4" Soft Washer	38	155/0564	5/16" BSF Socket Head Cap Screw 4"
5	514X.198	Pressure Switch	39	514X.109	Support Block
6	165/0428	1/4" BSF Socket Head Cap Screw 1 1/4" long	40	237/275	1 1/4" Conduit Plug
7	154/04	1/4" Spring Washer	41	--	3 station Manifold TAL No. GMC 103
8	514X.130	Cover Guide	42	165/204	2BA Round Head Screw 1/4" long
9	155/0510	5/16" BSF Socket Head Cap Screw 5/8"	43	292/2	Legend Plate
10	164/05	5/16" Spring Washer	44	292/4	Legend Plate
11	314Z.110C	End Bracket	45	101/26	2 3/4" External Circlip
12	--	Klippon Screw & Screw Bolt SB 13	46	154/03	2BA Spring Washer
13	--	Klippon 3 way Jumper Box Q13	47	156/228	2BA Socket Head Cap Screw 1 1/4" long
14	357/20	1 1/4" Soft Washer	48	--	Square D Limit Switch Class 9007 Type AW 36
15	156/210	2BA Socket Head Cap Screw 5/8" long	49	155/0524	5/16" BSF Socket Head Cap Screw 1 1/2" long
16	--	Klippon Marker Tag BS 65	50	154/05	5/16" Spring Washer
17	--	Klippon End Bracket EWK	51	357/10	5/8" Soft Washer
18	237/355	1 1/2" Entry Bush	52	514V.205	Support Bracket
19	328/10	3/8" Clip	53	514X.206	Gasket
20	326/1232	3/8" Tension Pin 2" long	54	247/1009	5/8" Conduit 9" long
21	--	Klippon End Section AP	55	154/06	3/4" Spring Washer
22	--	Klippon Terminal Type 5AK 2.5	56	155/0616	3/8" BSF Socket Head Cap Screw 1" long
23	514Y.108	Connection Box	57	514V.124B	Switch Bracket
24	514X.204	Assembly Rail	58	357/12	3/4" Soft Washer
25	203/2	2BA Locknut	59	237/1210	3/4"-5/8" Reducer
26	162/208	2BA Countersunk Head Screw 1 1/2" long	60	357/10	5/8" Soft Washer
27	292/3	Legend Plate	61	237/272	5/8" Conduit Plug
28	165/204	2BA Round Head Screw 1/4" long	62	166/404	4BA Round Head Screw 1/4" long
29	292/5	Legend Plate	63	291/3	Legend Plate
30	237/273	3/4" Conduit Plug	64	291/4	Legend Plate
31	514Y144/1	Solenoid operated Valve for 50 cycle supply	65	291/2	Legend Plate
	514Y144/2	Solenoid operated Valve for 60 cycle supply	66	237/302	5/8" Conduit Nipple
32	154/03	3/16" Spring Washer	67	237/82	3/8" Conduit Elbow
33	CAR SC	3/16" Whit. Screw 7/16" long	68	357/10	5/8" Soft Washer
34	154/03	3/16" Spring Washer			

List of Parts for
 Plate No.7A
 (Drawing No.314Z4B)

WHEN ORDERING SPARE PARTS ALWAYS QUOTE THE INSPECTION NUMBER OF THE MACHINE

END BRACKET & CONTROL UNIT ASSEMBLY
6 1/2"-6 CHUCKING MACHINE

Last Used On
Machine 15093

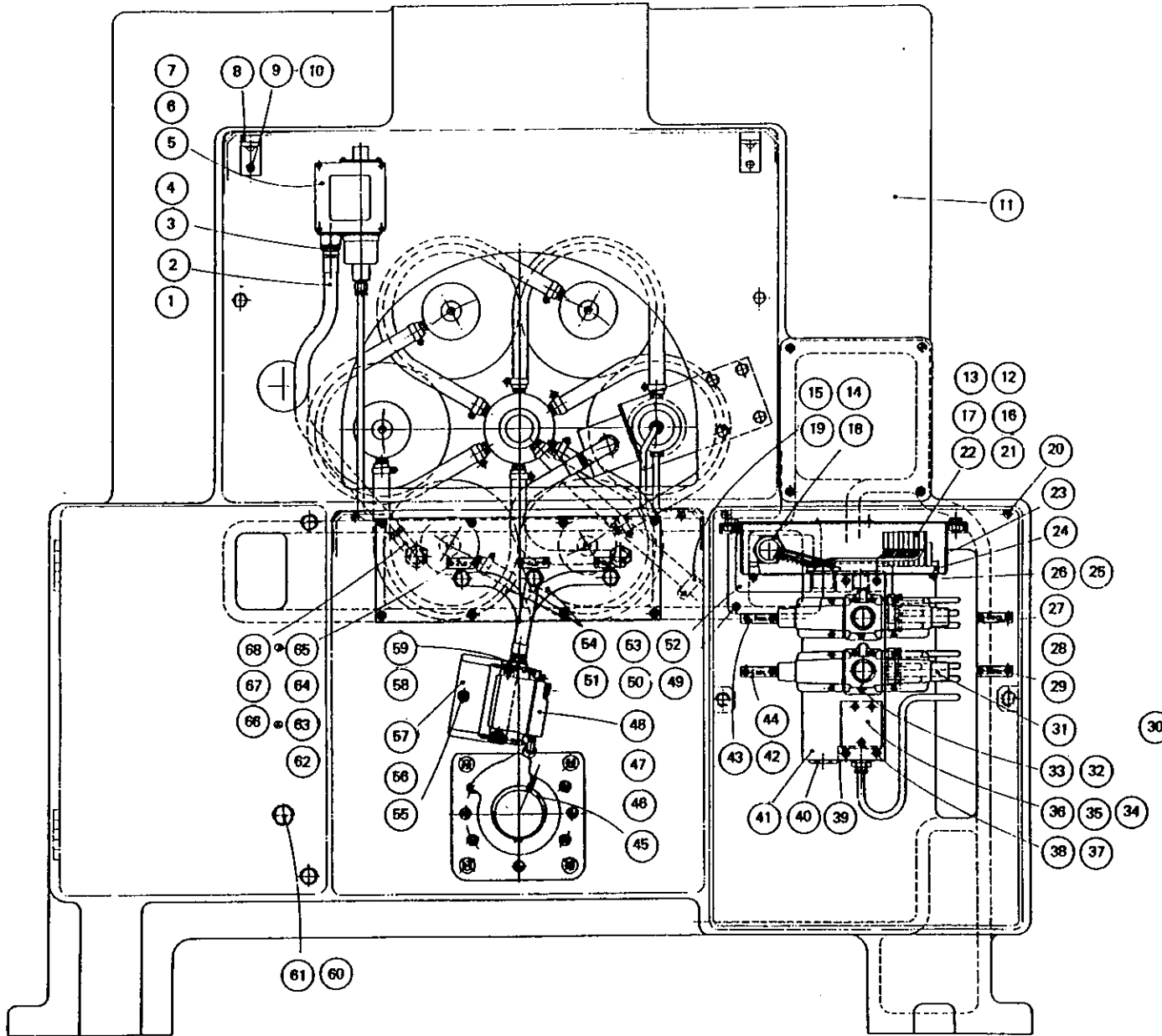

314 Z 4C ARRANGEMENT OF PNEUMATIC END BRACKET

6 $\frac{3}{4}$ "-6 MACHINE. SECTION 314

Commencing
M/c No.15094

INDEX NO.	PART NO.	TITLE	INDEX NO.	PART NO.	TITLE
1	6344	T & B Connector, 45°, 1 $\frac{1}{2}$ " Conduit	23	314 Z 110D	End Bracket
2	237/245	Locknut, 1 $\frac{1}{2}$ " Conduit	24	6361	Straight T & B Connector, $\frac{3}{8}$ " Conduit
3	—	Conduit, 1 $\frac{1}{2}$ ", Sealite Anaconda	26	237/242	Locknut, $\frac{3}{8}$ " Conduit
4	164/05	Spring Washer, for 5/16" dia.	26	614X.198	Square D Pressure Switch
5	155/0516	Socket Head Cap Screw, 5/16" B.S.F. x 1" long	27	165/0428	Socket Head Cap Screw, $\frac{1}{4}$ " B.S.F. x 1 $\frac{1}{4}$ " long
6	314Y.220	Manifold Mounting Plate	28	164/04	Spring Washer, for $\frac{1}{2}$ " dia.
7	165/0412	Socket Head Cap Screw, $\frac{1}{4}$ " B.S.F. x $\frac{3}{4}$ " long	29	160/208	Dome Head Screw, 2 B.A. x $\frac{1}{2}$ " long
8	357/20	Seal, 1 $\frac{1}{2}$ " Conduit	30	314Y.221	Blanking Plate
9	237/245	Locknut, 1 $\frac{1}{2}$ " Conduit	31	6341	T & B Connector, 45°, $\frac{3}{8}$ " Conduit
10	6364	Straight Connector, 1 $\frac{1}{2}$ " Conduit	32	237/1210	Reducer, $\frac{1}{2}$ " — $\frac{3}{8}$ " Conduit
11	164/05	Spring Washer, for 5/16" dia.	33	357/10	Seal, $\frac{3}{8}$ " Conduit
12	155/0544	Socket Head Cap Screw 5/16" BSP x 2 $\frac{1}{4}$ " long	34	357/12	Seal, $\frac{1}{4}$ " Conduit
13	165/204	Round Head Set Screw, 2 B.A. x $\frac{1}{2}$ " long	35	291/10	Legend Plate (Double Index Machine)
14	292/	Legend Plates	36	155/0510	Socket Head Cap Screw, 5/16" B.S.F. x $\frac{3}{8}$ " long
15	514V.144/2	Solenoid-Operated Valve	37	314Y.219	End Bracket Cover
16	GMC 1130	T.A.L. Manifold	38	291/5	Legend Plate
17	—	Cap Screw, 3/16" Whitworth, x $\frac{3}{4}$ " long	39	185/404	Round Head Set Screw, 4 B.A. x $\frac{1}{2}$ " long
18	G.P.10	T.A.L. Blanking Plate	40	155/0510	Socket Head Cap Screw, 5/16" B.S.F. x $\frac{3}{8}$ " long
19	237/235	Plug, 1 $\frac{1}{2}$ " Conduit	41	314Y.218	Camshaft Drive Cover
20	—	See 214 Y 7B for Pneumatic Assembly	42	—	See 315 Z 5 & 316 Z 6 for Arrangement of Front Camshaft Drive
21	291/31	Legend Plate			See also Wiring Diagram 371 Z 12D
22	165/404	Round Head Screw, 4 B.A. x $\frac{1}{2}$ " long			See also 614Z5C & 314Z6C

List of Parts for
Plate No. 7B
(Drawing No. 314 Z4C)

WHEN ORDERING SPARE PARTS ALWAYS QUOTE THE INSPECTION NUMBER OF THE MACHINE

PNEUMATIC END BRACKET
6 1/2"-6 CHUCKING MACHINES

Commencing
Machine No.15094

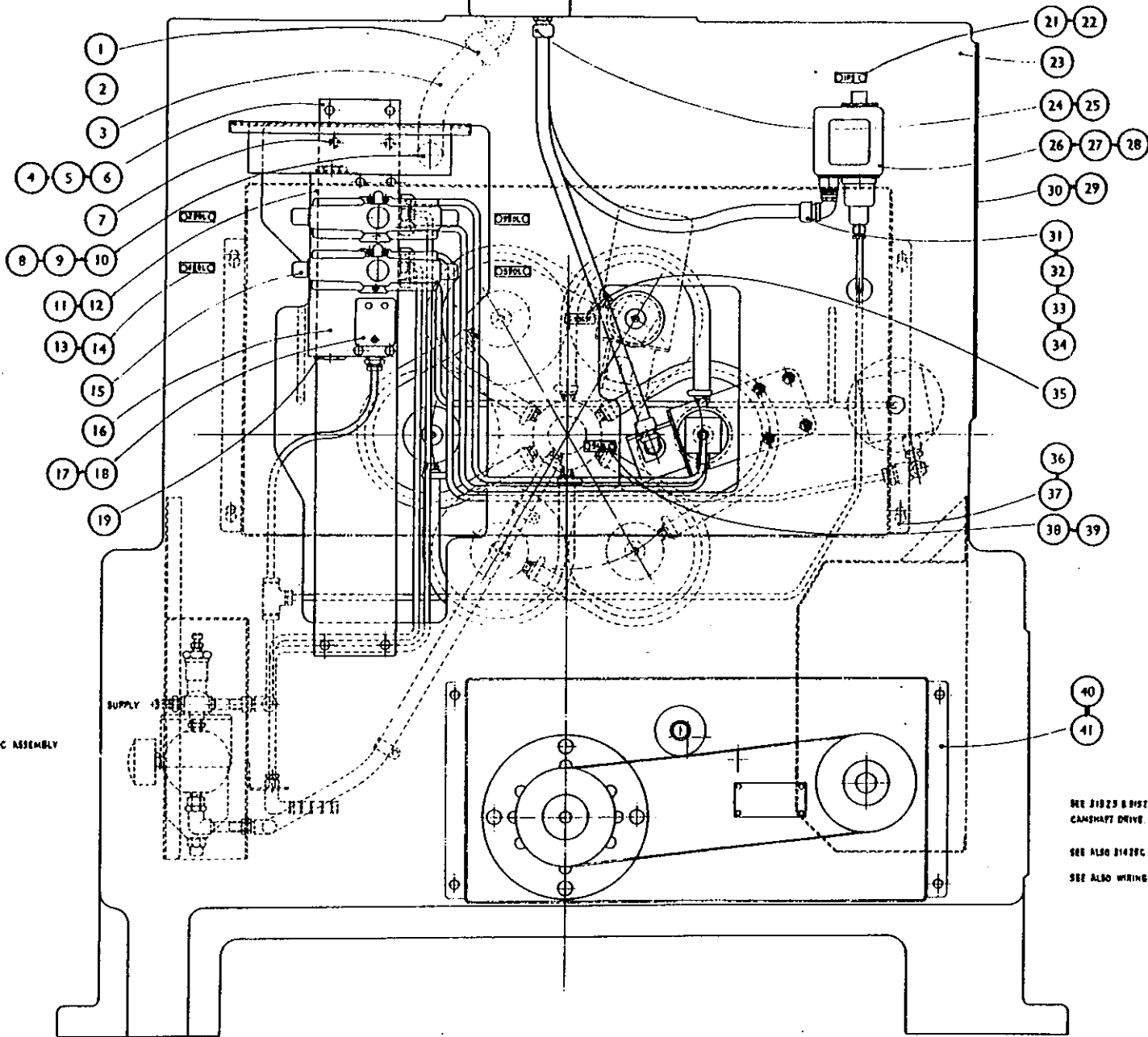

20

SEE 214Y7B FOR PNEUMATIC ASSEMBLY

42

SEE 318Z3 & 319Z6 FOR ARREST OF FRONT
CAMSHAFT DRIVE.

SEE ALSO 31429C & 31426C

SEE ALSO WIRING DIAGRAM 371Z12G

PLATE No.7B
(Drawing No.314Z4C)

WICKMAN
MULTI-SPINDLE
AUTOMATICS

END BRACKET AND CONTROL UNIT ASSEMBLY

6 $\frac{1}{2}$ " -6 CHUCKING MACHINE

Commenc
M/c No.95
Last Used
M/c No.11

INDEX NO.	PART NO.	TITLE	INDEX NO.	PART NO.	TITLE
1	614Y.112A	Connection Box	16	166/210	2B.A. Socket Head Cap Screw $\frac{3}{8}$ " long
2	24382	Crabtree Cover and Screw Assembly	16	314V.163B	Bracket
3	154/4	4B.A. Spring Washer	17	167/0510	5/16" B.S.F. Hexagon Head Set Screw $\frac{3}{8}$ " long
4	166/406	4B.A. Socket Head Cap Screw $\frac{3}{8}$ " long	18	198/12	Lockwasher
6	314V.167A	Guide Strip	19	314V.166A	Guide Strip
6	60400	Mounting Feet	20	372X.136	Instruction Plate
7	203/06	5/16" B.S.F. Self Locking Nut	21	165/406	4B.A. Round Head Set Screw $\frac{3}{8}$ " long
8	167/0610	5/16" B.S.F. Hexagon Head Set Screw $\frac{3}{8}$ " long	22	174/4	4B.A. Hexagon Nut
9	314Y.109	Bracket	23	Size 00	Jubilee Hose Clip
10	154/07	Spring Washer	24	236E	Draincock $\frac{1}{2}$ " B.S.P.
11	155/0712	7/16" B.S.F. Socket Head Cap Screw $\frac{3}{4}$ " long	25	11200-2	Norgren Filter and Drain
12	167/0512	5/16" B.S.F. Hexagon Head Set Screw $\frac{3}{8}$ " long	26	0-412	Norgren Lubricator
13	198/11	Lock Washer	27	2A.2-GG	Norgren Regulator
14	DAS.186/22	Pipe Clip			

List of Parts for
PLATE No.8
(Drawing No.314Z5A)

WHEN ORDERING SPARE PARTS ALWAYS QUOTE THE SERIAL NUMBER OF THE MACHINE

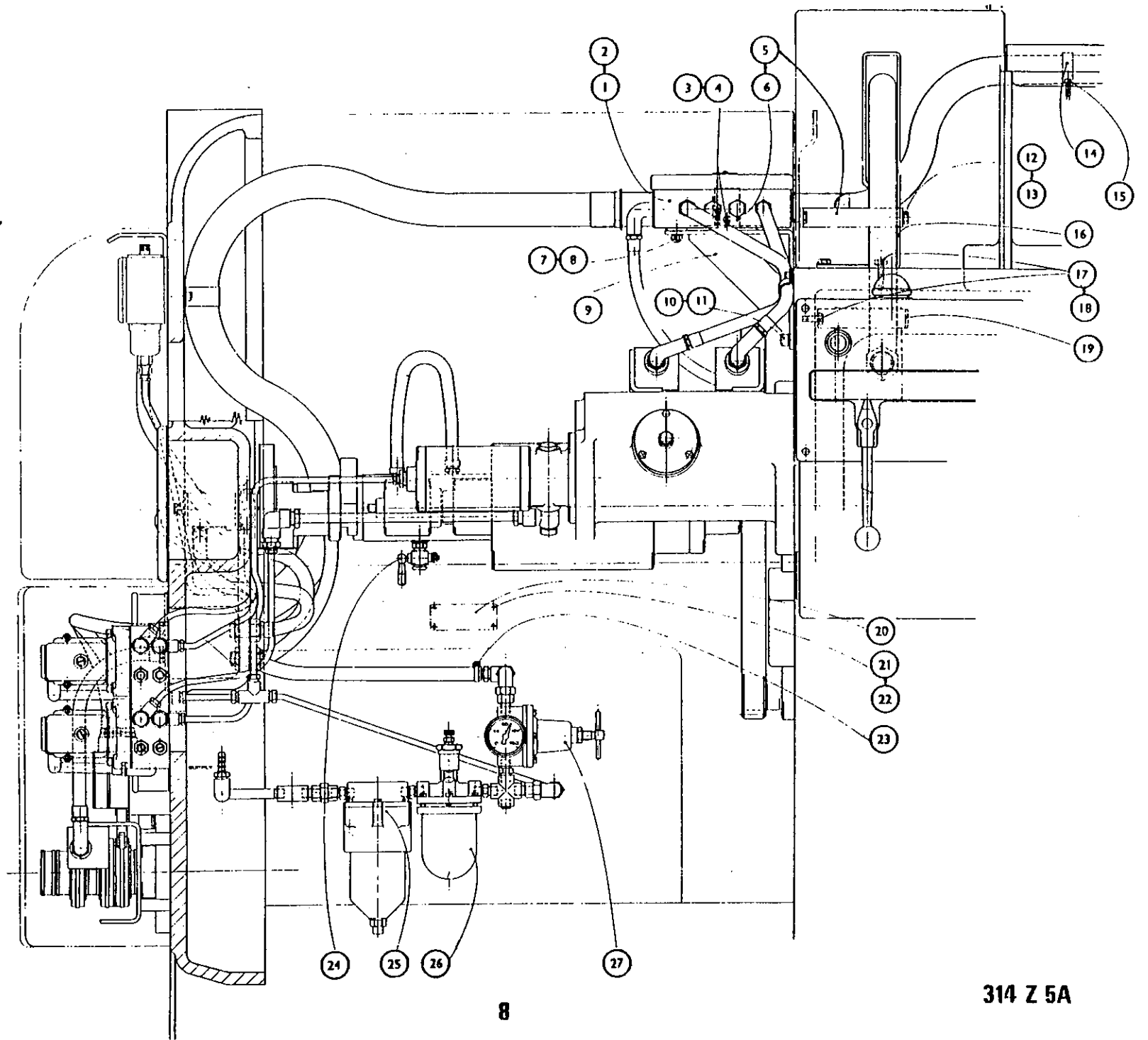

314 Z 5B END BRACKET & CONTROL UNIT ASSEMBLY

6 3/4" - 6 AIR CHUCKER. SECTIOC 314

First used on machine No.11638
Last used on machine No.15093

INDEX NO.	PART NO.	TITLE
1	165/404	4BA Round Head Screw 3/4" long
2	298A	Warning Plate
3	514Y.112C	Connection Box
4	314V.167A	Guide Strip
5	167/0512	5/16" BSF Hex. Head Set Screw 3/4" long
6	328/22	1 3/8" Pipe Clip
7	198/11	5/16" Lock Washer
8	156/210	2BA Socket Head Screw 5/8" long
9	314V.153B	Bracket
10	167/0510	5/16" BSF Hex. Head Set Screw 5/8" long
11	198/12	5/16" Lock Washer
12	314V.166A	Guide Strip
13	155/0712	7/16" BSF Socket Head Cap Screw 3/4" long
14	154/07	7/16" Spring Washer
15	314Y.109A	Bracket
16	167/0510	5/16" BSF Hex. Head Set Screw 5/8" long
17	203/05	3/8" BSF Pinnacle Nut
18	372X.136	Oil Plate
19	165/406	4BA Round Head Screw 3/8" long
20	174/4	4BA Hex. Nut
21	-	Jubilee Hose Clip Size 00
22	205/2	2BA Hex. Nut - Brass
23	165/208	2BA Round Head Screw 1/2" long
24	225/5	5/16" Pipe Clip
25	-	Norgren Regulator 20AG 2GG
26	-	Norgren Lubricator 0-41-2
27	-	Norgren Filter & Drain 30AG-2
28	-	1/2" BSP Drain Cock BSS 23GE
29	298A	Warning Plate
30	165/404	4BA Round Head Screw 3/4" long
31	514X.152	Adaptor
32	237/243	3/4" Conduit Locknut
33	237/272	3/8" Conduit Plug
34	357/12	3/4" Soft Washer
35	357/10	3/8" Soft Washer

List of Parts for
Plate No.8A
(Drawing No.314Z5B)

WHEN ORDERING SPARE PARTS ALWAYS QUOTE THE INSPECTION NUMBER OF THE MACHINE

END BRACKET AND CONTROL UNIT

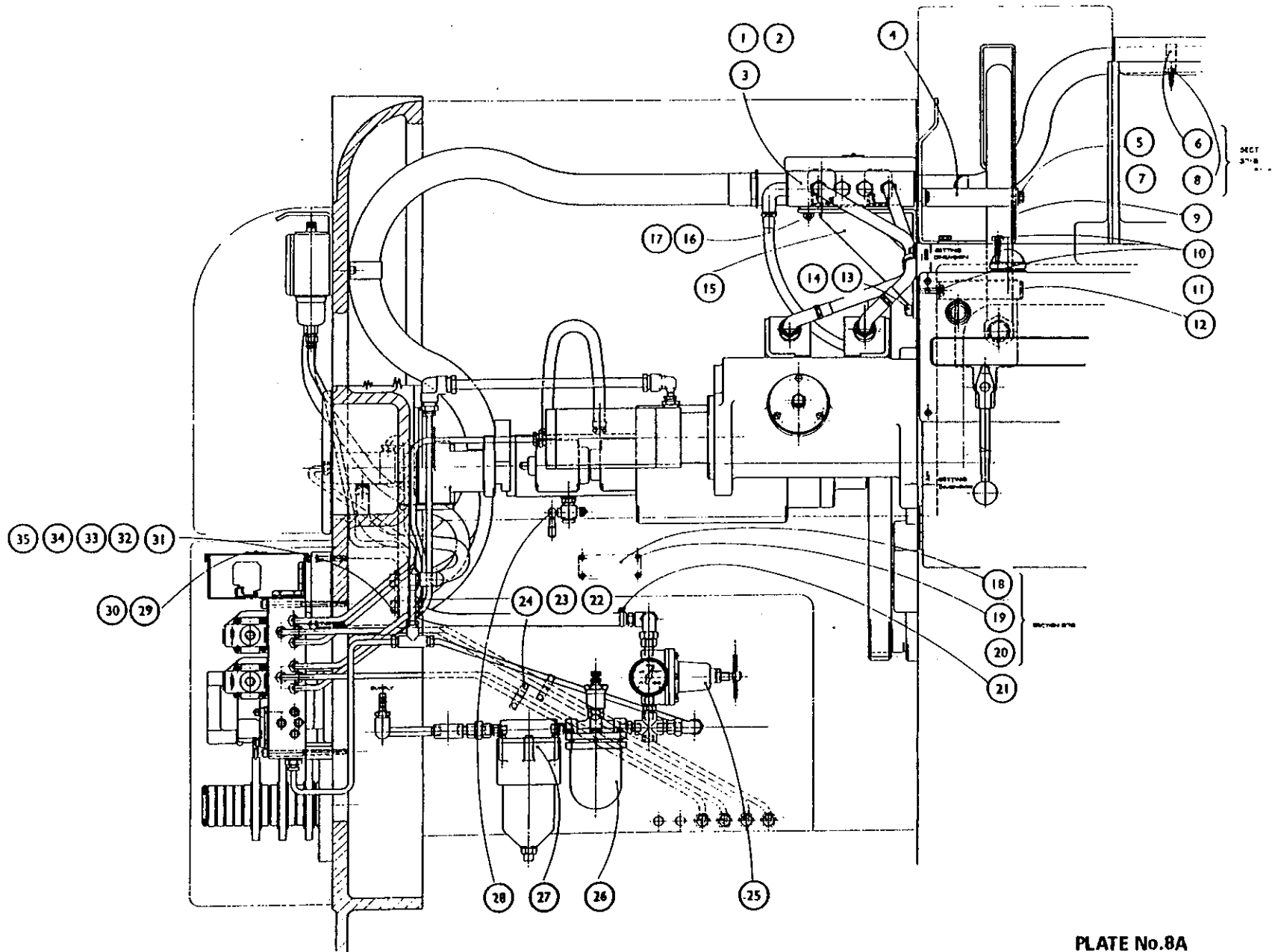

314 Z 5C BRACKET AND CONTROL UNIT ASSEMBLY

6 $\frac{1}{4}$ "-6, 6 $\frac{1}{2}$ "-6D MACHINES. SECTION 314

Commencing on
M/c No.15094

INDEX NO.	PART NO.	TITLE
1	-	Spindle Arrangement 303 Z 1 & 303 Z 2 Section 303
2	304X.159	Spacer
3	298A	Warning Plate
4	165/404	Round Head Set Screw, 4 B.A. x $\frac{1}{4}$ " long
5	514Y.108A	Connection Box
6	-	Position of chuck Operating Unit Section 514A
7	372X.136	Oil Plate
8	165/406	Round Head Set Screw, 4 B.A. x $\frac{3}{8}$ " long (Section 372)
9	174/4	Nut, 4 B.A. (Section 372)
10	-	For Pneumatic Pipe Fittings & References see Diagrammatic Circuit 214 Y /B
11	-	Also see 314 Z 4C & 314 Z 6C Also see Wiring Diagram 371 Z 12D

List of Parts for
Plate No. 8B
(Drawing No. 314 Z 5C)

WHEN ORDERING SPARE PARTS ALWAYS QUOTE THE INSPECTION NUMBER OF THE MACHINE

BRACKET AND CONTROL UNIT ASSEMBLY - REAR VIEW
6 1/2"-6 CHUCKING MACHINES

Commencing
Machine No. 15094

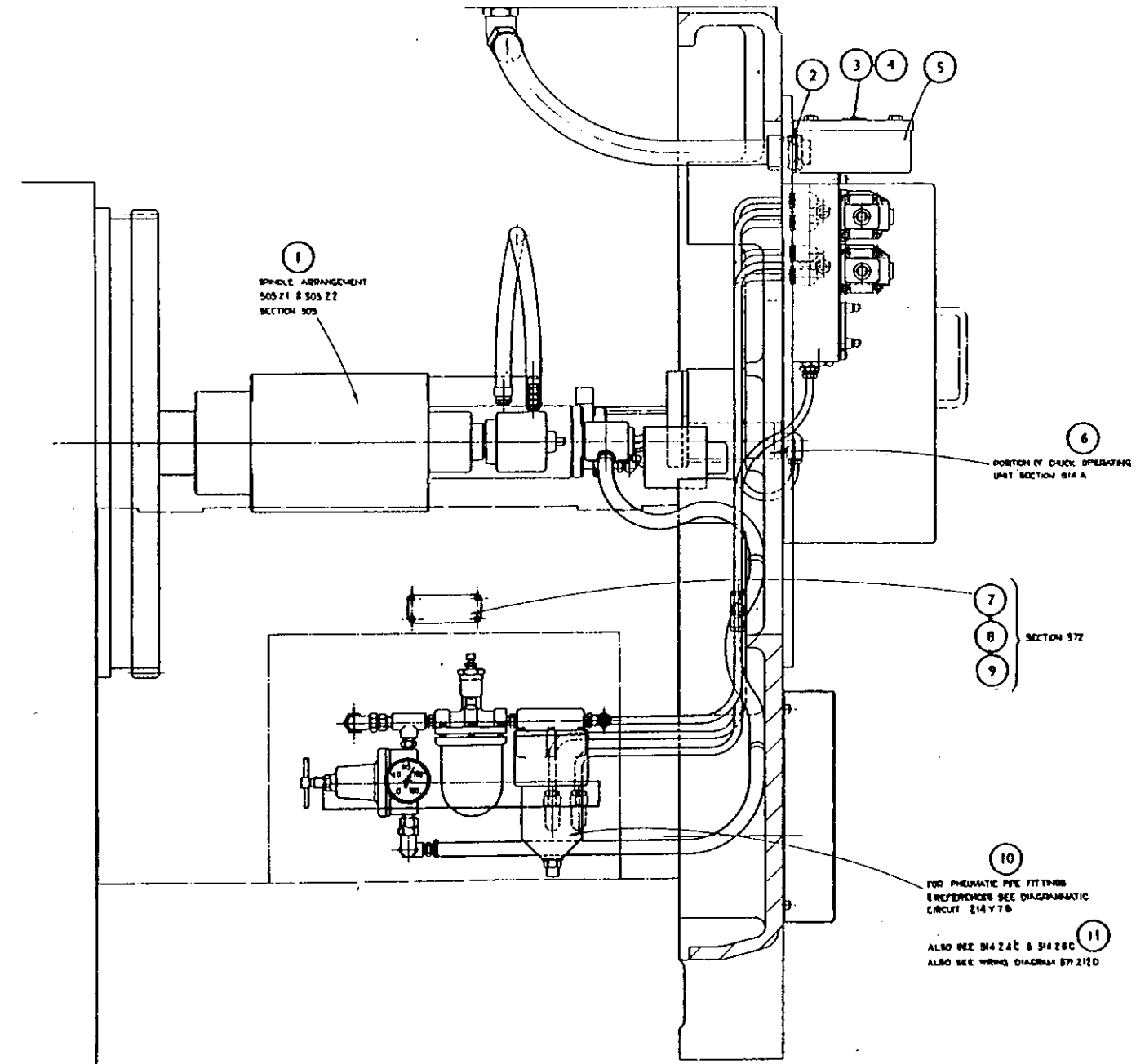

**WICKMAN
MULTI-SPINDLE
AUTOMATICS**

END BRACKET AND CONTROL UNIT ASSEMBLY

6 3/8" - 6, 6 3/8" - 6D CHUCKING MACHINE

Commencing on
M/c No.9546
Last Used on
M/c No.11637

INDEX NO.	PART NO.	TITLE	INDEX NO.	PART NO.	TITLE
1	237/355	Entry Bush 1 1/4" Conduit	40	514Y.120	Cam Switches Cover
2	237/85	Solid Elbow 1 1/4" Conduit	41	514X.149	Spacer
3	C.6496	Lead Washer	42	514Y.122	Upper Cover
4	Ref.5		43	514V.125	Channel Cover
	Type M.C.	Superflexit 1 1/4" Conduit 48" long	44	514V.128	Channel Cover Gasket
6	237/272	Hexagon Head Plug 5/8" Conduit	45	237/242	Locknut 3/8" Conduit
8	237/242	Locknut 3/8" Conduit	46	155/0512	5/16" B.S.F. Socket Head Cap Screw, 3/4" long
7	C.6492	Lead Washer 3/8"	47	143/0310A	Grooved Pin 3/32" dia. x 3/8"
8	Ref.5		48	514X.118	Cover Bolt
	Type M.C.	Superflexit 1 1/4" Conduit 77" long	49	130/06	Flat Washer 3/8"
9	237/245	Hexagon Locknut, 1 1/4" Conduit	50	237/246	Hexagon Locknut 1 1/4" Conduit
10	156/210	2 B.A. Socket Head Cap Screw 3/8" long	51	C.6497	Lead Washer 1 1/2"
11	DAS.185/10	Pipe Clip 3/8"	52	155/0612	5/16" B.S.F. Socket Head Cap Screw 1/2" long
12	Ref.2		53	514X.155	Pipe Clip
	Type M.C.	Superflexit 5/8" Conduit x 31" long	54	SJ 1	Supply Joint
13	237/82	Solid Elbow 3/8" Conduit	55	155/0512	5/16" B.S.F. Socket Head Cap Screw 3/4" long
14	237/302	Nipple 5/8" Conduit	56	314X.152	Gasket
15	C.6492	Lead Washer 3/8"	57	C.6492	Lead Washer 3/8"
16	237/1210	Reducer 3/4" - 3/8" Conduit	58	237/352	Entry Bush 1 1/4" Conduit
17	C.6493	Lead Washer 3/8"	59	237/82	Solid Elbow 3/8" Conduit
18	314Y.123B	Fixed Front Cover	60	C.6497	Lead Washer 1 1/2"
19	314Y.150	Centre Stem	61	Ref.6	
20	-	1" B.S.P. Nut		Type M.C.	Superflexit 1 1/2" Conduit x 53" long
21	167/0628	3/8" B.S.F. Hexagon Head Set Screw 1 3/4" long	62	C.6492	Lead Washer 3/8"
22	198/13	Lockwasher 3/8"	63	Ref.2	
23	314X.106	Packing Plate		Type M.C.	Superflexit 5/8" Conduit 31" long
24	Ref.2		64	156/210	2 B.A. Socket Head Screw 3/8" long
	Type M.C.	Superflexit 3/4" Conduit 16" long	65	DAS.185/10	Pipe Clip 3/8"
25	155/0510	5/16" B.S.F. Socket Head Cap Screw 3/8" long	66	237/1210	Reducer 3/4" - 3/8" Conduit
26	514X.152	Adaptor	67	C.6493	Lead Washer 3/8"
27	314X.178	Support Plate	68	167/0520	5/16" B.S.F. Hexagon Head Set Screw 1 1/4" long
28	156/210	2 B.A. Socket Head Cap Screw 3/8" long	69	130/05	Flat Washer 5/16"
29	154/03	2 B.A. Spring Washer	70	514X.131	Adaptor
30	237/243	Locknut 3/8" Conduit	71	514X.154	Gasket
31	514V.129	Switch Cover Gasket	72	203/05	5/16" B.S.F. Self-Locking Hexagon Nut
32	514V.111	Changeover Switch Cover	73	514X.157	Terminal Label
33	155/0514	5/16" B.S.F. Socket Head Cap Screw 3/8" long	74	50452	Terminal Block 15 way 19 amp.
34	514Y.194	Cover for Solenoid Valves	75	52363	Terminal Block Cover 15 way
35	C.6493	Lead Washer 3/8"	76	52294	Socket Clamp 19 amp Double
36	237/1210	Reducer 3/4" - 3/8" Conduit	77	50936	Cable Ferrules
37	C.6492	Lead Washer 3/8"	78	242	Cable Marker
38	237/302	Nipple 3/8" Conduit	79	514X.158	Terminal Label
39	237/82	Solid Elbow 3/8" Conduit			

List of Parts for
PLATE No.9
(Drawing No.314Z6A)

WHEN ORDERING SPARE PARTS ALWAYS QUOTE THE SERIAL NUMBER OF THE MACHINE

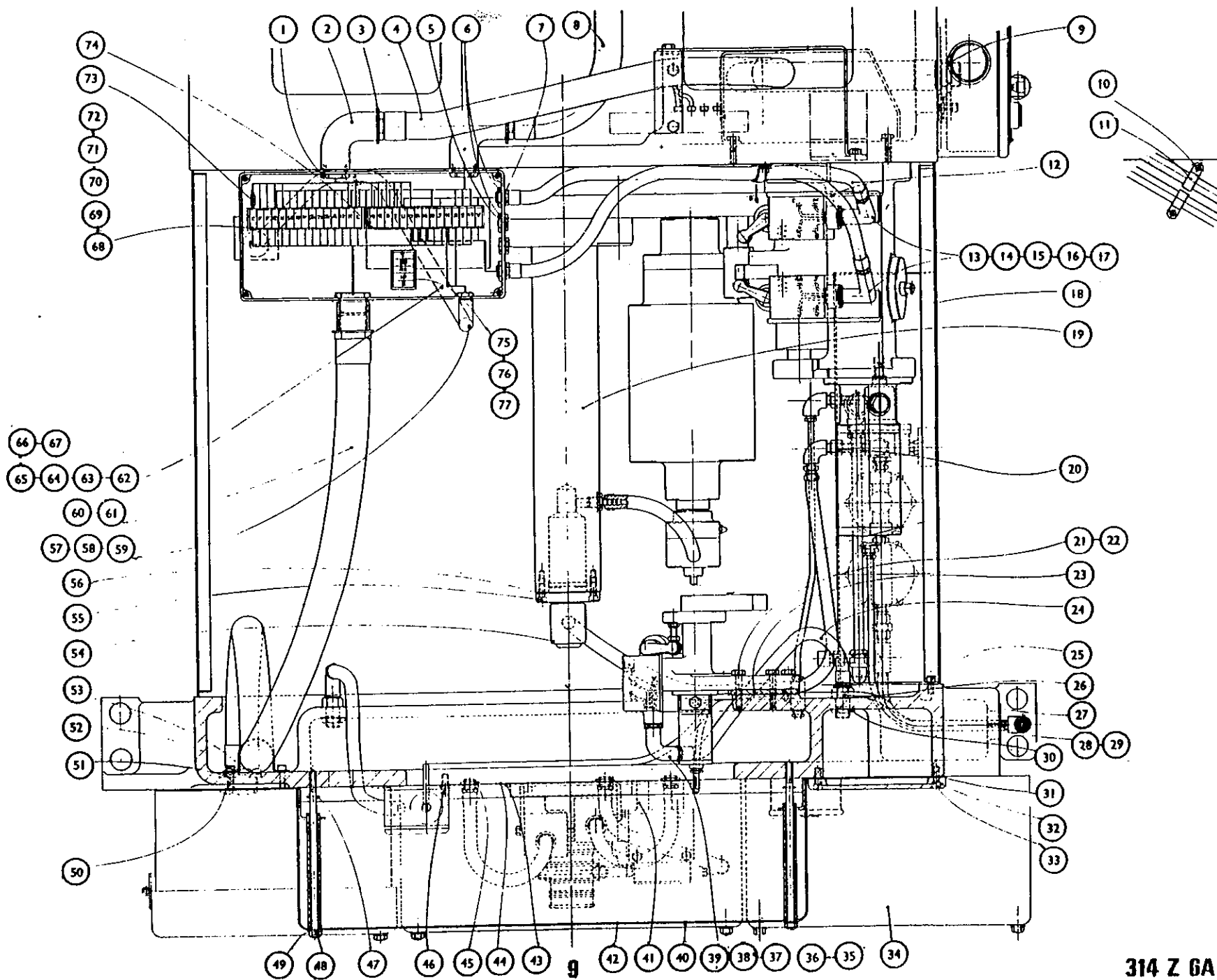

314 Z 6A

314 Z 6B END BRACKET & CONTROL UNIT ASSEMBLY

6 3/4" - 6 AIR CHUCKER. SECTION 314

Last used on
machine No.15093

INDEX NO.	PART NO.	TITLE	INDEX NO.	PART NO.	TITLE
1	257/355	1 1/4" Conduit Entry Bush	42	514V.122	Upper Cover
2	257/85	1 1/4" Conduit Elbow	43	514V.125A	Channel Cover
3	357/20	1 1/4" Soft Washer	44	514V.128	Channel Cover Gasket
4	—	Klippon End Section Type AP	45	165/0512	5/16" BSF Socket Head Cap Screw 3/4" long
5	247/2046	1 1/4" Conduit 46"	46	326/0310	3/32" Tension Pin 5/8" long
6	237/272	5/8" Conduit Plug	47	514X.118	Cover Bolt
7	237/242	5/8" Conduit Locknut	48	130/06	3/8" Flat Washer
8	357/10	5/8" Soft Washer	49	237/242	5/8" Conduit Locknut
9	247/2061	1 1/4" Conduit 61" long	50	514X.152	Adaptor
10	237/245	1 1/2" Conduit Nut	51	357/12	1/2" Soft Washer
11	357/20	1 1/4" Soft Washer	52	237/243	3/4" Conduit Locknut
12	166/210	2BA Socket Head Cap Screw 5/8" long	53	237/246	1 1/2" Conduit Locknut
13	328/10	5/8" Pipe Clip	54	357/24	1 1/2" Soft Washer
14	247/1031	5/8" Conduit 31" long	55	165/0512	5/16" BSF Socket Head Cap Screw 3/4" long
15	357/10	5/8" Soft Washer	56	514X.155	Pipe Clip
16	357/12	3/4" Soft Washer	57	—	Running Joint Lang 5J 1
17	237/1210	3/4" - 5/8" Conduit Reducer	58	165/0512	5/16" BSF Socket Head Cap Screw 3/4" long
18	357/10	5/8" Soft Washer	59	314X.152	Gasket for Running Joint
19	237/302	5/8" Conduit Nipple	60	237/82	5/8" Conduit Elbow
20	237/102	5/8" Conduit Short Arm Elbow	61	237/352	3/4" Conduit Entry Bush
21	314Y.123A	Fixed Front Cover	62	357/10	3/4" Soft Washer
22	314Y.150	Centre Stem	63	247/2453	1 1/2" Conduit 53" long
23	—	1/4" BSP Hex. Nut Brass	64	357/24	1 1/2" Soft Washer
24	198/13	3/8" Lock Washer	65	247/1031	3/8" Conduit 31" long
25	167/0628	3/8" BSF Hex. Head Set Screw 1 1/4" long	66	357/10	3/8" Soft Washer
26	314X.106	Packing Plate	67	357/12	3/4" Soft Washer
27	165/0510	5/16" BSF Socket Head Cap Screw 5/8" long	68	237/1210	3/4" - 3/8" Conduit Reducer
28	314X.178	Support Plate	69	328/10	5/8" Pipe Clip
29	154/03	3/16" Spring Washer	70	166/210	2BA Socket Head Cap Screw 3/8" long
30	166/210	2BA Socket Head Cap Screw 5/8" long	71	237/206	1 1/2" Conduit Coupler
31	514V.129	Switch Cover Gasket	72	237/356	1 1/2" Conduit Entry Bush
32	514V.111A	Change over Switch Cover	73	—	Klippon Terminal Type SAR 2.5
33	165/0520	5/16" BSF Socket Head Cap Screw 1 1/4" long	74	—	Klippon Marker Tag Type BS 65
34	514V.194A	Cover for Solenoid Valves	75	—	Klippon End Bracket Type EWK
35	357/12	3/4" Soft Washer	76	514X.207	Assembly Rail
36	237/1210	3/4" - 5/8" Conduit Reducer	77	162/208	2BA Counter Sunk Head Screw 1/2" long
37	357/10	5/8" Soft Washer	78	203/2	2BA Hex. Nut
38	237/302	5/8" Conduit Nipple	79	—	Screw & Screw Bolt SB 13
39	237/102	5/8" Conduit Short Arm Elbow	80	—	Klippon 3 way Jumper Box. QL3
40	514Y.120A	Cam Switches Cover	81	—	Klippon 2 way Jumper Box. QL2
41	247/1014	3/8" Conduit 14" long	82	—	Klippon Screw & Screw Bolt SB 13.

List of Parts for
Plate No.9A
(Drawing No.314Z6B)

WHEN ORDERING SPARE PARTS ALWAYS QUOTE THE INSPECTION NUMBER OF THE MACHINE

6 1/2" - 6 CHUCKING MACHINE

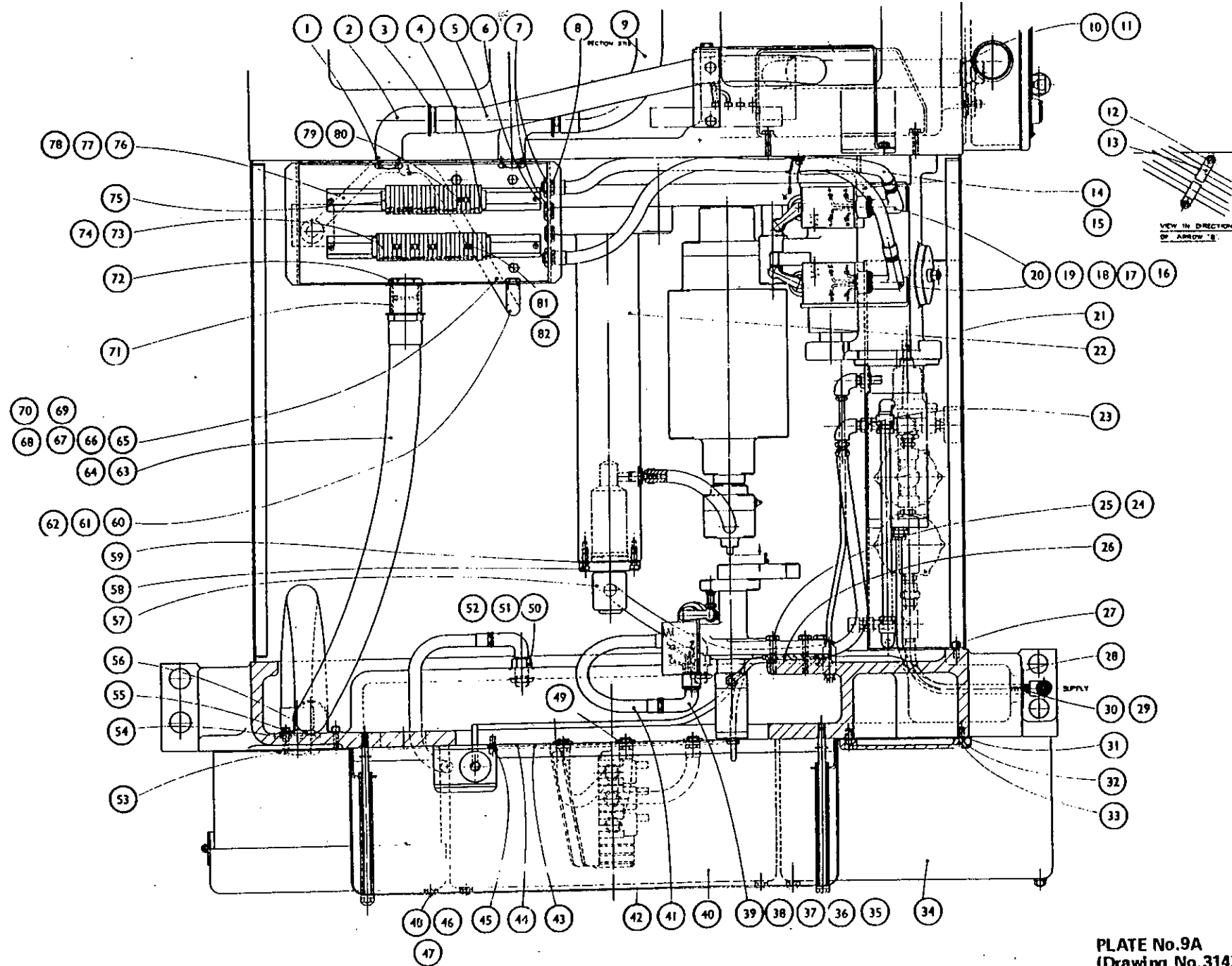

PLATE No.9A
(Drawing No.31426B)

314 Z 6C END BRACKET & CONTROL UNIT ASSEMBLY – PLAN VIEW

6 $\frac{1}{2}$ "-6 HYDRAULIC CHUCKER. SECTION 314

Commencing
No. 15094

INDEX NO.	PART NO.	TITLE
1	—	Spindle Stopping Unit Arrangement 304 Z 1 Section 304. 6 $\frac{1}{2}$ "-6
2	314Y160	Centre Stem
3	167/0628	$\frac{3}{8}$ BSF Hex. Head Set Screw 1 $\frac{1}{2}$ " long
4	198/13	$\frac{3}{8}$ Lockwasher
5	—	See Wiring Diagram 371 Z 12D Also see 314 Z 4C & 314 Z 5C
6	—	Running Joint. Leng 5J 1.
7	314X.152	Gasket for Running Joint
8	165/0612	5/16 BSF Socket Head Cap Screw $\frac{3}{4}$ " long
9	—	For Pneumatic Pipe Fittings & References see Diagrammatic Circuit 214Y7B

List of Parts for
Plate No.9B
(Drawing No.314Z6C)

WHEN ORDERING SPARE PARTS ALWAYS QUOTE THE INSPECTION NUMBER OF THE MACHINE

END BRACKET AND CONTROL UNIT ASSEMBLY. PLAN VIEW

6 $\frac{1}{2}$ "-6 CHUCKING MACHINE

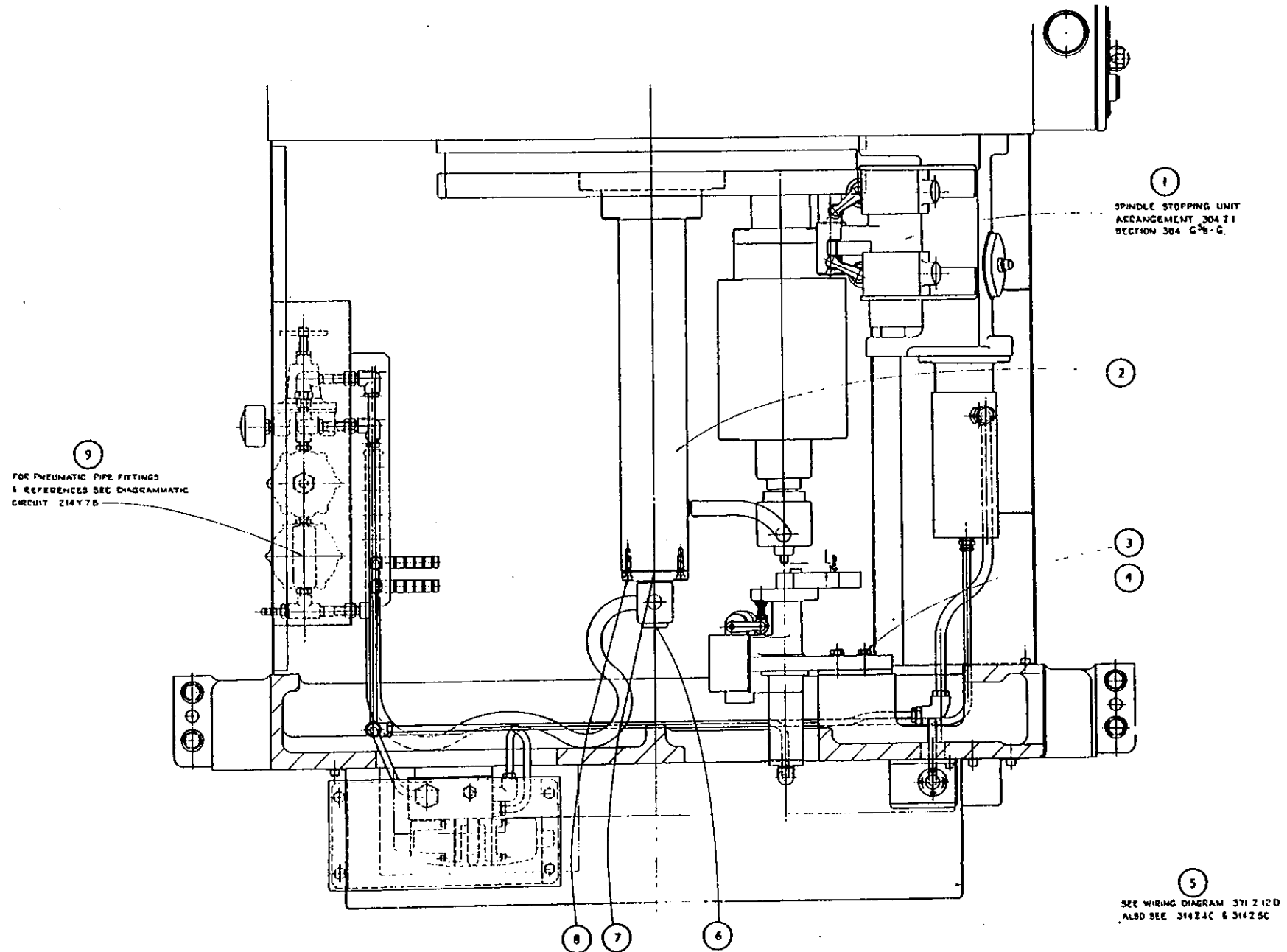

PLATE No.9B
(Drawing No.314Z6C)

**WICKMAN
MULTI-SPINDLE
AUTOMATICS**

**END BRACKET AND CONTROL ASSEMBLY
6 $\frac{3}{8}$ "-6 AND 6 $\frac{3}{8}$ "-6D CHUCKING MACHINES**

**Obsolete
Last Used On
M/c No.9545**

FOR LOCATION OF PARTS SEE TABLE ON PLATE 10

**List of Parts for
PLATE No. 10
(Drawing No. 314 Z 15)**

WHEN ORDERING SPARE PARTS ALWAYS QUOTE THE SERIAL NUMBER OF THE MACHINE

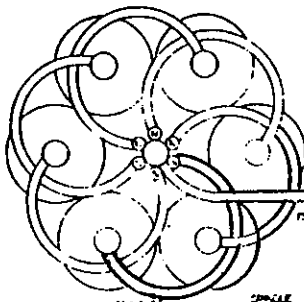

PARTS REF.	DESCRIPTION	DRAWING OR MFR. NO. (QUANTITIES IN BRACKETS)				SUPPLIER'S REF. (QUANTITIES IN BRACKETS)
		1	2	3	4	
A	TUBE ADAPTER	1	1	1	1	
B	ELBOW ADAPTER	1	1	1	1	
C	TUBING TEE CONNECTOR	1	1	1	1	
D	WHEEL TUBE ADAPTER	1	1	1	1	
E	REDUCING CONNECTOR	1	1	1	1	
F	ELBOW CONNECTOR	1	1	1	1	
G	PERMANENT ELBOW MULTIPLE	1	1	1	1	
H	THROTTLE VALVE	1	1	1	1	
J	ELBOW FITTING	1	1	1	1	
K	TEE CONNECTOR	1	1	1	1	
L	HEAVY DUTY NIPPLE	1	1	1	1	
M	ORF	1	1	1	1	
N	WHEEL CONNECTOR	1	1	1	1	
P	WHEEL BRACKET	1	1	1	1	
Q	WHEEL CONNECTOR	1	1	1	1	
R	WHEEL BRACKET	1	1	1	1	
S	WHEEL CONNECTOR	1	1	1	1	
T	WHEEL CONNECTOR	1	1	1	1	

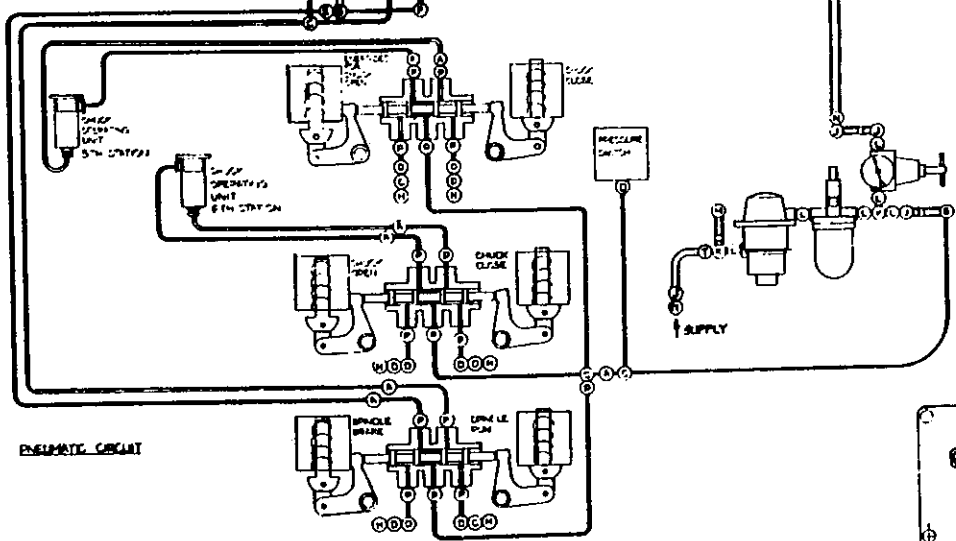

PNEUMATIC CIRCUIT

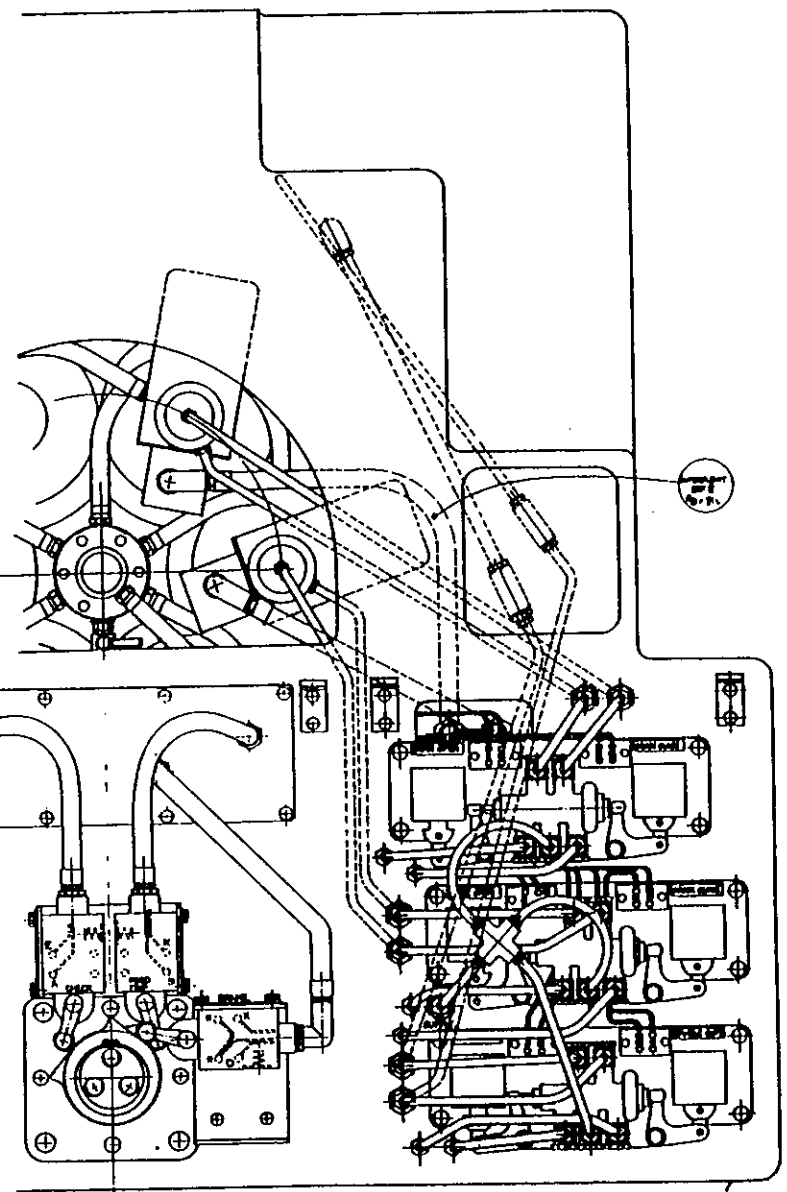

WICKMAN
MULTI-SPINDLE
AUTOMATICS

END BRACKET ASSEMBLY
6 $\frac{1}{2}$ " --6D CHUCKING MACHINE

Commencing
M/c No. 9546

INDEX NO.	PART NO.	TITLE
1	2A.2--GG	Norgren Regulator
2	314X.119A	Connection Tube
3	11200--2	Norgren Filter and Drain
4	0--41--2	Norgren Lubricator
5	514V.197	Terminal Box
6	Type M.C. Ref.1	$\frac{1}{2}$ " Superflexit Conduit 10 $\frac{1}{2}$ " long
7	Type M.C. Ref.2	$\frac{3}{8}$ " Superflexit Conduit 21" long

List of Parts for
PLATE No.10A
(Drawing No.314Z15A)

WHEN ORDERING SPARE PARTS ALWAYS QUOTE THE SERIAL NUMBER OF THE MACHINE

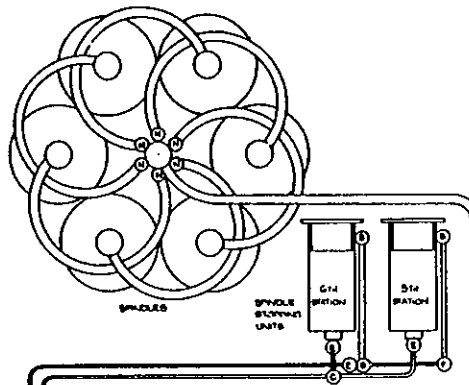

ITEM REF	DESCRIPTION	DRAWING OR SHOP NO	QUANTITIES IN BRACKET ¹	SUPPLIES FOR IN BRACKET ²
A	SOCKET PIPE PLUG	1/2 C	104/11 (3)	
B	ELBOW ADAPTOR	1/2 T	224/16 (1)	221/10 (1)
C	TURNING TEE CONNECTOR	1/2 T	277/6 (1)	221/10 (1)
D	MALE TUBE ADAPTOR	1/2 B	226/10 (1)	221/10 (1)
E	REDUCING CONNECTOR	1/2 T	222/10 (1)	221/10 (1)
F	ELBOW CONNECTOR	1/2 T	227/7 (1)	221/10 (1)
G	FEMALE ELBOW ADAPTOR	1/2 T	228/10 (1)	221/10 (1)
H	THROTTLE VALVE	1/2 B		424/10 PER 2-10 (1)
J	ELBOW (FEMALE)	1/2 B		226 325V (1)
K	TEE CONNECTOR	1/2 B		226 325V (1)
L	HEXAGON NUT	1/2 B		226 325V (1)
M	GAP	1/2 B		226 325V (1)
N	NOSE CONNECTOR	1/2 B		SCHRADE G-302
P	SINGLE SHUNTER	1/2 T	Z0229/4 (1)	221/10 (1)
Q	FOUR WAY CONNECTOR	1/2 T	Z0220/8 (1)	221/10 (1)
R	SOCKET PIPE PLUG	1/2 C	104/11 (1)	
S	TURNING TEE CONNECTOR	1/2 T	277/6 (1)	221/10 (1)
T	UNION 1/2 GAS MALE - 1/2 GAS FEMALE	1/2 B		226 325V (1)
U	UNION 1/2 GAS MALE - 1/2 GAS FEMALE	1/2 B		226 325V (1)
V	UNION ELBOW 1/2 GAS MALE - 1/2 GAS FEMALE	1/2 B		

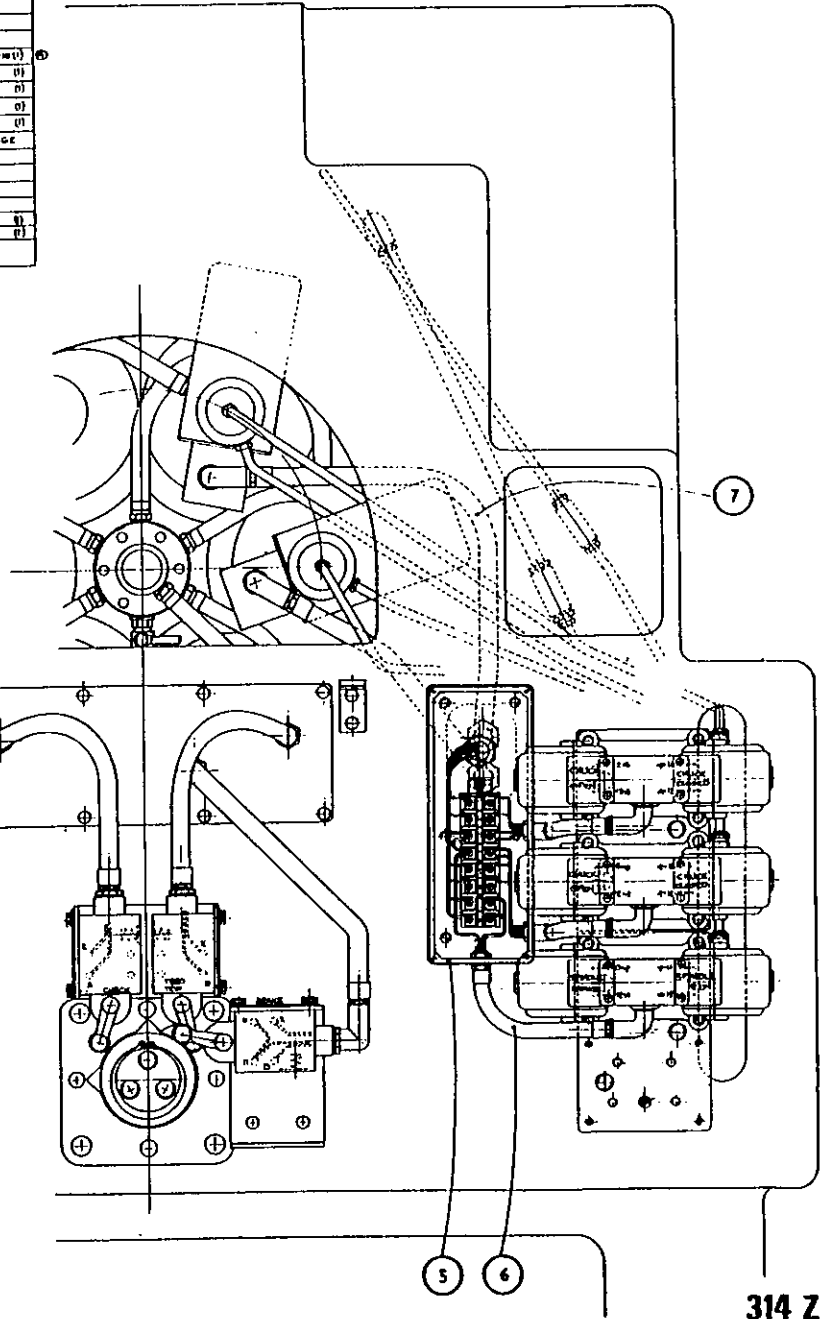
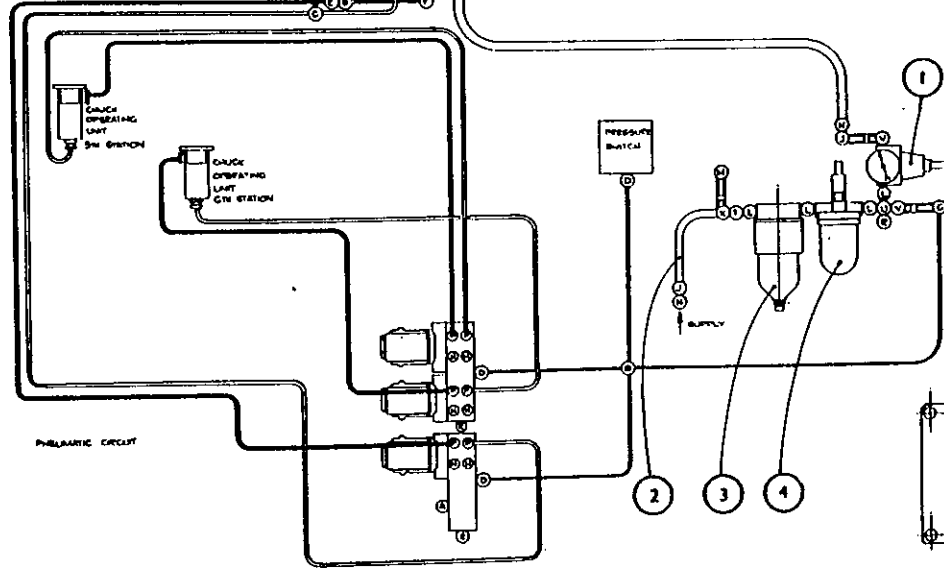

WICKMAN
MULTI-SPINDLE
AUTOMATICS

END BRACKET AND CONTROL ASSEMBLY PNEUMATIC CIRCUIT

6 $\frac{1}{4}$ " -6, 6 $\frac{1}{4}$ " -6D CHUCKING MACHINES

Commencing
M/c No. 9546
Last Used On
M/c No. 11637

INDEX NO.	PART NO.	TITLE
1	SJ.1	Lang Supply Joint
2	-	Air Hose 5/16" Bore 18" long
3	603X.240A	
4	214V.172	Base
5	514V.193	Solenoid Operated Valve/1-50 cycle/2-60 cycle.
6	225/818	Copper Tube 1/2" dia.
7	ACW.1	
8	225/5050	Copper Tube 5/16" dia.
9	314X.119A	Connection Tube
10	--	Air Hose, Bore 5/16"
11	514X.116	Connector
12	2A.2-GG	Norgren Regulator
13	514X.116	Connector
14	0-41-2	Norgren Lubricator
16	11200-2	Norgren Filter and Drain

List of Parts for
PLATE No.11
(Drawing No.214Y7)

WHEN ORDERING SPARE PARTS ALWAYS QUOTE THE SERIAL NUMBER OF THE MACHINE

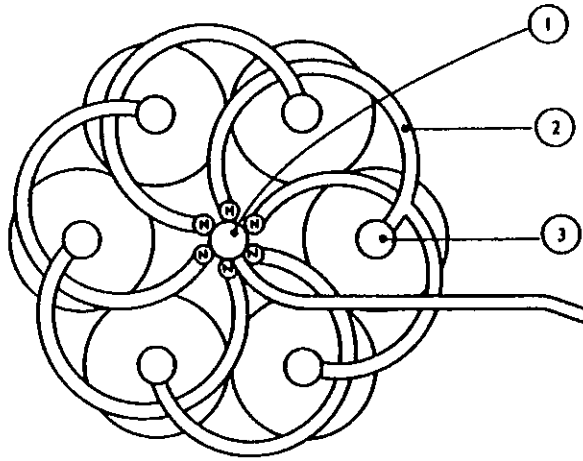

FITTING BOX	DESCRIPTION	QUANTITIES	W&P N. (IN BRACKETS)		SUPPLIER REF. (QUANTITIES IN BRACKETS)
A	BAND	1/8" WT. 208/0814(1)	218/3 (1)	221/7 (1)	
B	ELBOW ADAPTOR	1/2" T. 244/0 (1)	218/12 (1)	221/10 (1)	
C	TUBING TEE CONNECTOR	1/2" T. 217/6 (1)	218/9 (A)	221/7 (5)	
D	MALE TUBE ADAPTOR	1/8" WT. 210/16 (1)	218/9 (1)	221/7 (1)	
E	REDUCING CONNECTOR	1/2" T. 226/20(1)	218/9 (1)	221/7 (1)	
F	ELBOW CONNECTOR	1/2" T. 227/7 (1)	218/12 (1)	221/10 (1)	
G	FEMALE ELBOW ADAPTOR	1/8" WT. 228/8 (1)	218/9 (1)	221/7 (1)	
H	THROTTLE VALVE	1/4"			MAKAPFER-10 (
J	ELBOW FEMALE	1/4"			888 810V. (
K	TEE CONNECTOR	1/4"			888 820V. (
L	HEXAGON NIPPLE	1/4"			888 820V. (
M	CAP	1/4"			888 822V. (
N	HOSE CONNECTOR	1/4" WT			SCHLADER G367
P	UNION 1/4 GAS MALE-1/4 GAS FEMALE				888 85E. (
Q	FOUR WAY CONNECTOR	1/4"			888 822V. (
R	SOCKET WPC PLUS	1/4"	194/E (1)		
S	UNION ELBOW 1/4 GAS MALE-1/4 GAS FEMALE				888 87E. (
T	MALE TUBE ADAPTOR	1/4" WT	218/9 (1)		
U	REDUCER	1/2" T	208/8/01	218/9 (1)	221/7 (1)
V	MALE TUBE ADAPTOR	1/8" WT	248/1401		

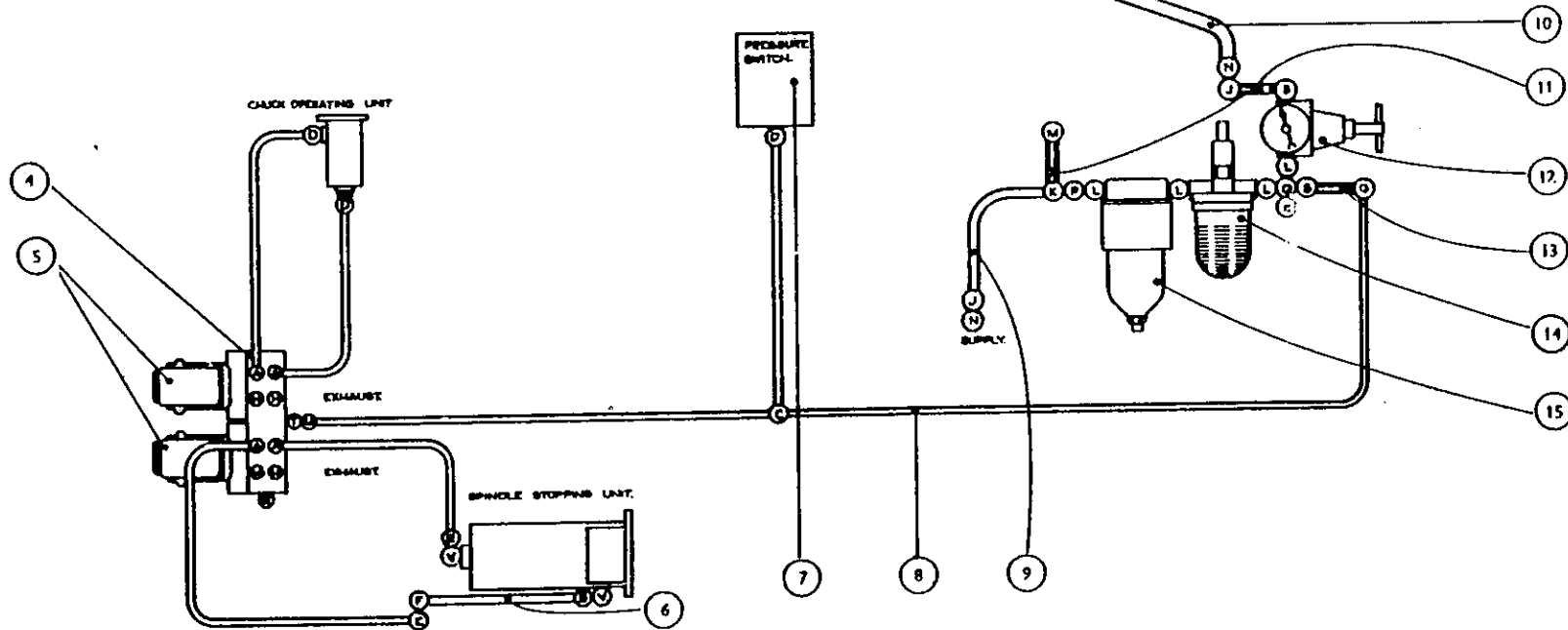

214 Y 7A PNEUMATIC CIRCUIT DIAGRAM

6 $\frac{1}{4}$ "-6, 6 $\frac{1}{4}$ "-6D CHUCKING MACHINES

First Used on Machine 1
Last Used on Machine K

INDEX NO.	PART NO.	TITLE
1	SJ 1	Long Supply Joint
2	—	Air Hose 5/16" Bore 18" long
3	503X.248A	Valve Joint
4	Size 00	Jubilee Hose Clip
5	GMC 103	3 Station Manifold
6	514V.144/1	Solenoid Operated Valve for 60 cycle supply
	514V.144/2	Solenoid Operated Valve for 60 cycle supply
7	GP 10	Blanking Plate
8	225/818	1/2" Dia. Copper Tube
9	Type ACW 1	Pressure Switch Square D Class 9012
10	225/6050	5/16" Dia. Copper Tube
11	314X.119A	Connection Tube
12	30AG-2	Norgren Filter & Drain
13	0-41-2	Norgren Lubricator
14	514X.116	Connector
15	20AG-2GG	Norgren Lubricator
16	514X.116	Connector
17	—	5/16" Bore, Air Hose, 30" long
18	G 203	TAL Silencer/Regulator

List of Parts for
Plate No.11A
(Drawing No.214Y7A)

WHEN ORDERING SPARE PARTS ALWAYS QUOTE THE INSPECTION NUMBER OF THE MACHINE

First Used On
Machine No.11638
Last Used On
Machine No.15093

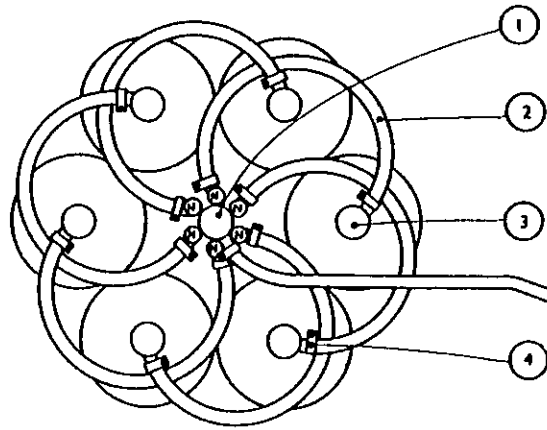

FITTING REF.	DESCRIPTION	W.S.P. NO. (QUANTITIES IN BRACKETS.)			SUPPLIERS REF. NO. (QUANTITIES IN BRACKETS.)
		244/8 (1)	215/12 (1)	221/10 (1)	
A					
B	ELBOW ADAPTOR 1/2T.	244/8 (1)	215/12 (1)	221/10 (1)	
C	TUBING TEE CONNECTOR 3/16T.	217/6 (1)	215/9 (3)	221/7 (3)	
D	MALE TUBE ADAPTOR 1/4G 3/16T	215/10 (1)	215/9 (1)	221/7 (1)	
E	REDUCING CONNECTOR 1/2T. 3/16T	236/20 (1)	215/9 (1)	221/7 (1)	
F	ELBOW CONNECTOR 1/2T	227/7 (1)	215/12 (1)	221/10 (1)	
G	FEMALE ELBOW ADAPTOR 1/4G 3/16T	215/8 (1)	215/9 (1)	221/7 (1)	
H					
J	ELBOW FEMALE 1/4G.				B55 516V (1)
K	TEE CONNECTOR 1/4G				B55 520V (1)
L	HEXAGON NUT/FL. 1/4G.				B55 526V (1)
M	CAP 1/4G.				B55 522V (1)
N	HOSE CONNECTOR 1/4G 3/16T				SCHRADER 6362
P	UNION 1/4G MALE - 1/4 GAS FEMALE				B55 55R (1)
Q	FOUR WAY CONNECTOR 1/4G				B55 522V (1)
R	SOCKET PIPE PLUG 1/4G.	194/2 (1)			
S	UNION ELBOW 1/4 GAS MALE - 1/4 GAS FEMALE				B55 57R (1)
V	MALE TUBE ADAPTOR 1/2G 1/2T	215/26 (1)	215/12 (1)	221/10 (1)	
W	MALE TUBE ADAPTOR 1/2G 3/16T	215/16 (1)	215/9 (1)	221/7 (1)	
X	FEMALE ADAPTOR 1/4G 3/16T	220/15 (1)	215/9 (1)	221/7 (1)	
Y	SOCKET PIPE PLUG 1/2G.	194/4 (1)			
Z	HEX. HEAD PLUG. 1/2 COND.	237/25 (1)			

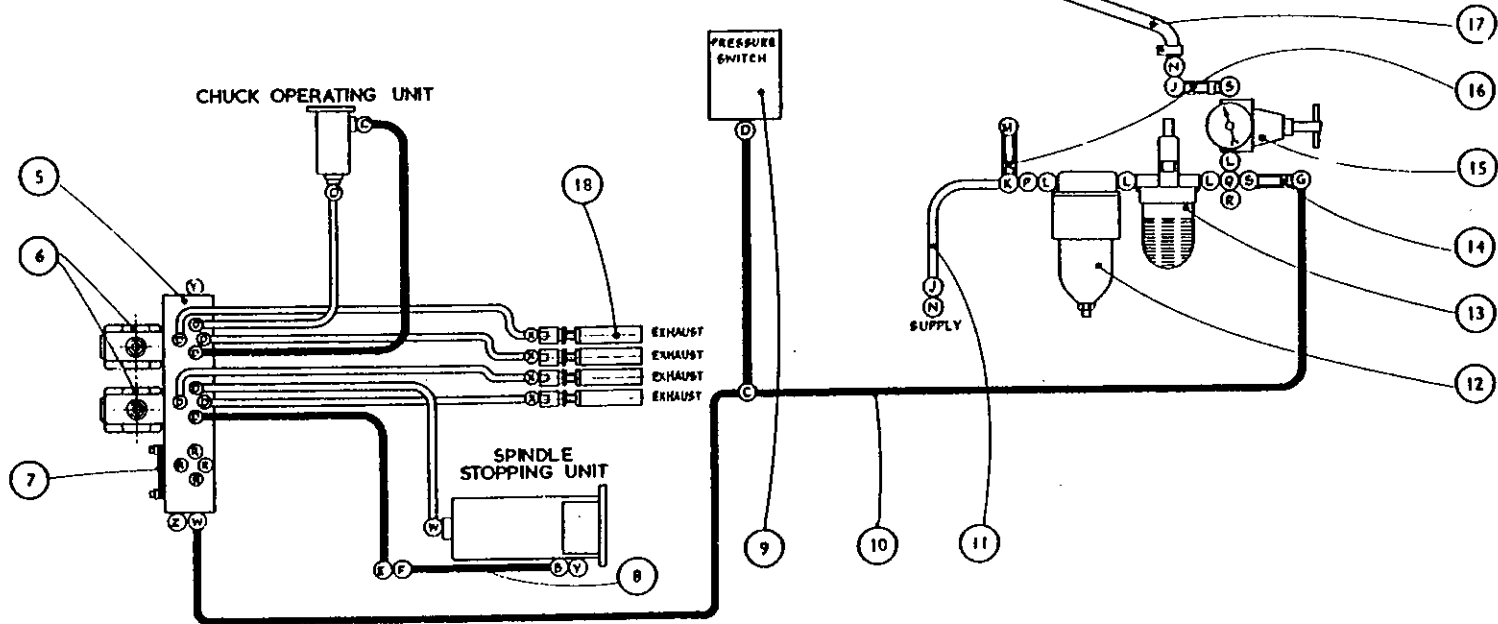

214 Y 7C PNEUMATIC CIRCUIT DIAGRAM
6 1/2"-6, 6 1/4"-6D CHUCKING MACHINES. SECTION 314

**Commencing
Machine No.15094**

INDEX NO.	PART NO.	TITLE
1	SJ 1	Lang Supply Joint
2	—	Air Hose 5/16" Bore 18" long
3	VJ 1	Air Cylinder
4	Size 00	Jubilee Hose Clip
5	G 201	TAL Silencer
6	—	Air Hose 5/16" Bore. 30" long
7	514X.116	Connector
8	—	1/4" BSP Hexagon Nut
9	20AG-2GG	Norgren Regulator
10	514X.116	Connector
11	0-41-2E	Norgren Lubricator
12	F02-200-A3TB	Norgren Filter & Drain
13	—	See also 214Z11
14	14.02.810	8m/m Copper Tube
16	Type ACW 1	Pressure Switch Square D Class 9012
16	14.02.1212	12m/m Copper Tube
17	GP 10	TAL Blanking Plate
18	514V.144/1	Solenoid Operated Valve for 50 cycle supply
	514V.144/2	Solenoid Operated Valve for 60 cycle supply
19	GMC 1130	3 Station Manifold

**List of Parts for
Plate No.11B
(Drawing No.214Y7C)**

WHEN ORDERING SPARE PARTS ALWAYS QUOTE THE INSPECTION NUMBER OF THE MACHINE

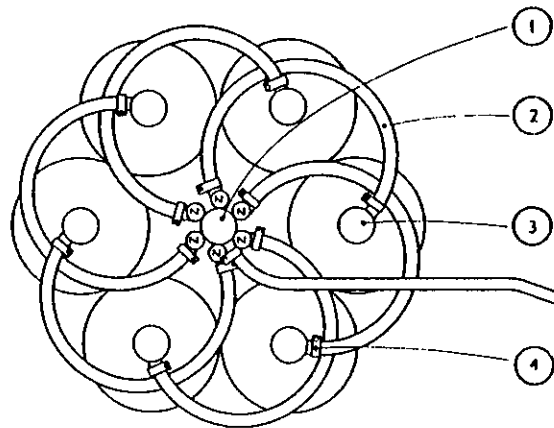

20 FITTING REF	DESCRIPTION	WICKMAN METRIC STANDARD N° & WSP N° (QUANTITIES IN BRACKETS)			SUPPLIERS REF N° (QUANTITIES IN BRACKETS)
A					
B	STEM ELBOW CONNECTOR 12mm-T	14.54.1212 (1)	14.07.12 (1)	14.08.12 (1)	
C	TEE CONNECTOR 8mm-T	14.05.08 (1)	14.07.08 (3)	14.08.08 (2)	
D	STRAIGHT MALE ADAPTOR 1/8" BSP-B-T	14.72.0804 (1)	14.07.08 (1)	14.08.08 (1)	
E	REDUCING CONNECTOR 12mm-T-8mm-T	14.11.0812 (1)	14.07.08 (1)	14.08.08 (1)	
F	ELBOW CONNECTOR 12mm-T	14.04.12 (1)	14.07.12 (1)	14.08.12 (1)	
G	FEMALE ELBOW ADAPTOR 1/8" BSP-R-T	14.35.0804 (1)	14.07.08 (1)	14.08.08 (1)	
H	1/4 G FEMALE ELBOW	315 x 16"	215/9 (1)	221/7 (1)	
J	ELBOW FEMALE 1/4 G				B55 516V (1)
K	TEE CONNECTOR 1/4 G				B65 520V (1)
L	HEXAGON NIPPLE 1/4 G				B55 526V (1)
M	CAP 1/4 G				B56 532V (1)
N	HOSE CONNECTOR 1/4 G 5/16 T				SCHRADER 63C
P	UNION 1/4 GAS MALE-1/4 GAS FEMALE				B55 55R (1)
Q	FOUR WAY CONNECTOR 1/4 G				B55 522V (1)
R	SOCKET PIPE PLUG 1/4 G	194/2 (1)			
S	UNION ELBOW 1/4 GAS MALE-1/4 GAS FEMALE				B55 57R (1)
T	MALE ELBOW ADAPTOR 1/8" BSP-B-T	14.75.0804 (1)	14.07.08 (1)	14.08.08 (1)	
V	STRAIGHT MALE ADAPTOR 1/8" BSP-12-T	14.72.1208 (1)	14.07.12 (1)	14.08.12 (1)	
W	STRAIGHT MALE ADAPTOR 1/8" BSP-8-T	14.72.0808 (1)	14.07.08 (1)	14.08.08 (1)	
X					
Y	SOCKET PIPE PLUG 1/2 G	194/4 (1)			
Z	HEX HEAD PLUG 1/4 COND	25/4 275 (1)			

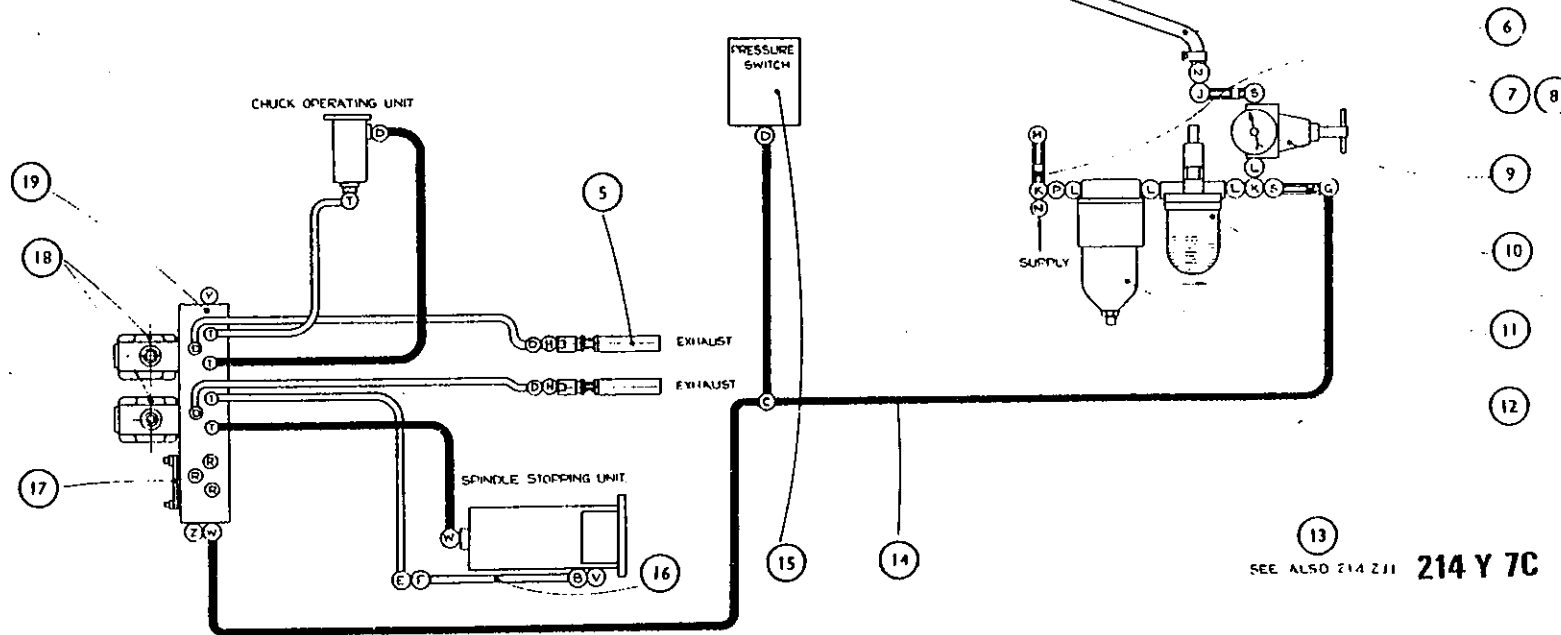

SEE ALSO 214 Z11 214 Y 7C

214 Y 8A PNEUMATIC CIRCUIT DIAGRAM
6 1/2"-6D CHUCKING MACHINES. SECTION 314

INDEX NO.	PART NO.	TITLE
1	—	5/16" Air Hose 18" long
2	Size 00	Jubilee Clip
3	SJ1	Lang Supply Joint
4	UJ1	Air Cylinder
5	14.02.1212	12m/m Copper Tube
6	—	5/16" Air Hose 30" long
7	514X.116	Connector
8	—	1/4" BSP Hexagon Nut
9	20 AG- 2GG	Norgren Regulator
10	514X.116	Connector
11	0-41-2E	Norgren Lubricator
12	F02-200-A3TB	Norgren Filter & Drain
13	—	See also 214212
14	514X.118	Connector
15	14.02.810	8m/m Copper Tube
16	ACW 1	Pressure Switch Square D Class 9012
17	GMC 1130	TAL Manifold
18	514V.144/2	Solenoid Operated Valve 60 Cycle
19	G201	ASB Silencer

List of Parts for
 Plate No.11C
 (Drawing No.214Y8A)

WHEN ORDERING SPARE PARTS ALWAYS QUOTE THE INSPECTION NUMBER OF THE MACHINE

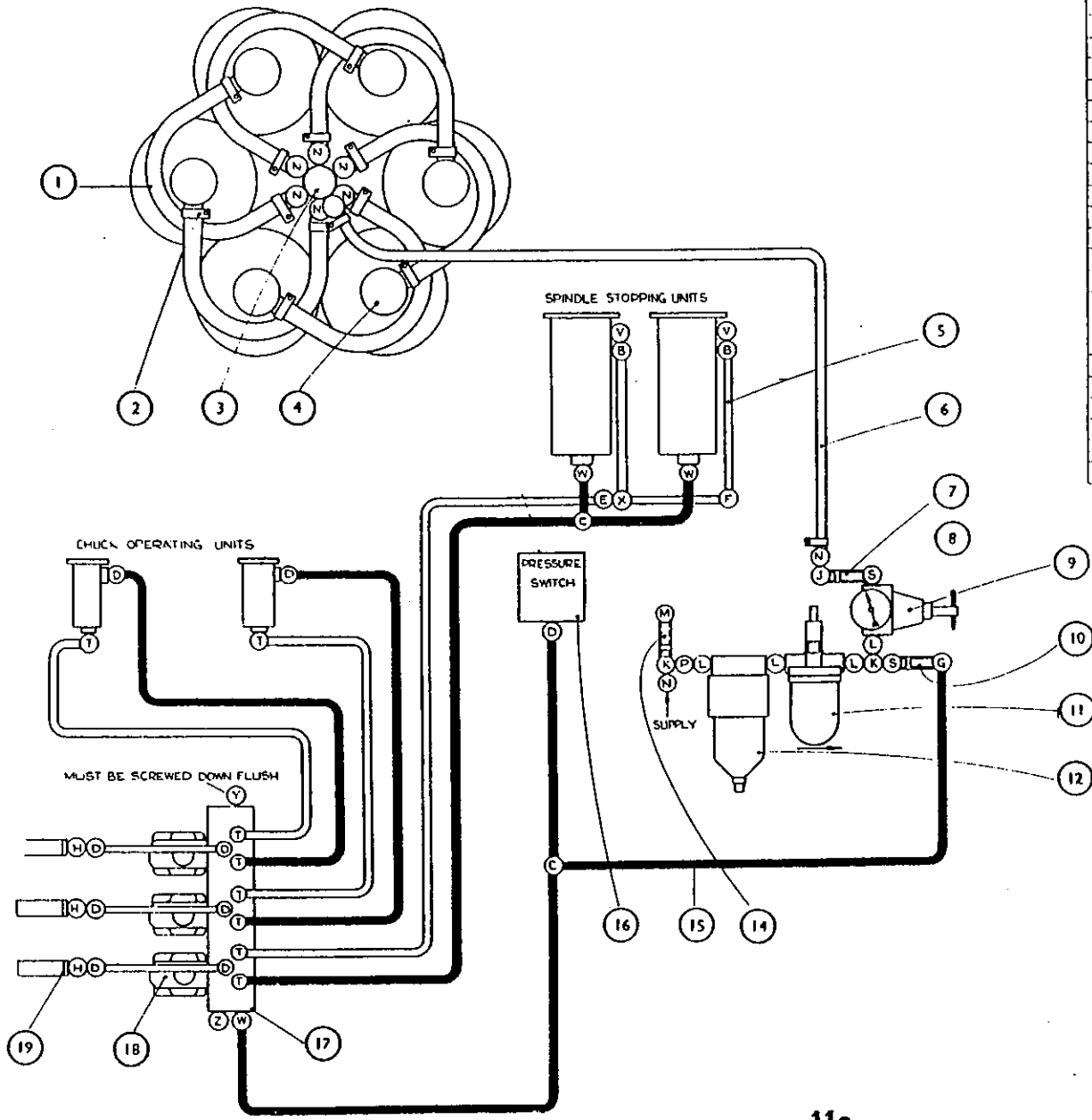

FITTING REF	DESCRIPTION	WSP N ^o s (QUANTITIES IN BRACKETS) & WICKMAN METRIC STANDARD N ^o s			SUPPLIER REF N ^o
					(QTY IN BRACKETS)
A					
B	STEM ELBOW CONNECTOR 12-T	14.54.12(2)	14.07.12(1)	14.08.12(1)	
C	TEE CONNECTOR 8-T	14.05.08(1)	14.07.08(1)	14.08.08(1)	
D	STRAIGHT MALE ADAPTOR 1/2 BSP-8-T	14.72.0804(1)	14.07.08(1)	14.08.08(1)	
E	REDUCING CONNECTOR 12-T-8-T	14.11.0812(1)	14.07.08(1)	14.08.08(1)	
F	ELBOW CONNECTOR 12-T	14.04.12(1)	14.07.12(1)	14.08.12(1)	
G	FEMALE ELBOW ADAPTOR 1/2 BSP-8-T	14.35.0804(1)	14.07.08(1)	14.08.08(1)	
H	1/4 G FEMALE ELBOW	315 X 127	215 2 (1)	221.7 (1)	
J	ELBOW FEMALE 1/4 G				BSS 517 (1)
K	TEE CONNECTOR 1/4 G				BSS 527
L	HEXAGON NIPPLE 1/4 G				BSS 526 (1)
M	CAP 1/4 G				BSS 532 (1)
N	HOSE CONNECTOR 1/4 G 3/16 T				BSS 527 (1)
P	UNION 1/4 G MALE 1/4 G FEMALE				BSS 554 (1)
Q	FOUR WAY CONNECTOR 1/4 G				BSS 522 (1)
R	SOCKET PIPE PLUG 1/4 G	192/2 (1)			
S	UNION ELBOW 1/4 G MALE 1/4 G FEMALE				BSS 512 (1)
T	MALE ELBOW ADAPTOR 1/2 BSP-8-T	14.75.0804(1)	14.07.08(1)	14.08.08(1)	
V	STRAIGHT MALE ADAPTOR 1/2 BSP-12-T	14.72.1208(1)	14.07.12(1)	14.08.12(1)	
W	STRAIGHT MALE ADAPTOR 1/2 BSP-8-T	14.72.0808(1)	14.07.08(1)	14.08.08(1)	
X	TEE CONNECTOR 12-T	14.05.12(1)	14.07.12(1)	14.08.12(1)	
Y	SOCKET PIPE PLUG 1/2 G	194/4 (1)			
Z	HEX HD PLUG 1/4 COND	237/275(1)			

13
SEE ALSO 214Z12. 214 Y 8A

**WICKMAN
MULTI-SPINDLE
AUTOMATICS**

**CHUCK OPERATING UNIT
6 $\frac{1}{4}$ "-6 AND 6 $\frac{1}{4}$ "-6D CHUCKING MACHINES**

INDEX NO.	PART NO.	TITLE	INDEX NO.	PART NO.	TITLE
1	198/8	$\frac{1}{4}$ " Lockwasher	12	514X.107	5/16" Pin
2	514X.103	Switch Plate	13	212/18	$\frac{1}{4}$ " B.S.P. Autolub Nipple
3	16D.1200	B.S.A. Acme Snap Lock Switch	14	210/2525	Plastic Indicator Washer (Yellow)
4	167/0520	5/16" B.S.F. Hex. Head Set Screw, 1 $\frac{1}{4}$ " long	15	178/0710	5/16" B.S.F. Socket Head Set Screw (Half-Dog) $\frac{3}{8}$ " long
5	203/05L	5/16" B.S.F. Simmonds Locknut	16	514X.102B	Trip Plate Pivot
6	203/06	$\frac{3}{8}$ " B.S.F. Simmonds Hex. Nut	17	514X.101B	Trip Plate
7	170/0636	$\frac{3}{8}$ " B.S.F. Hex. Head Bolt, 2 $\frac{1}{4}$ " long	18	143/1036B	5/16" dia. Mills Grooved Pin, 2 $\frac{1}{4}$ " long
8	514X.165A	Air Cylinder, Double Acting	19	143/1014B	5/16" dia. Mills Grooved Pin, $\frac{7}{8}$ " long
9	156/210	2B.A. Socket Head Cap Screw, $\frac{3}{8}$ " long	20	125/1624	$\frac{1}{4}$ " dia. Taper Pin, 1 $\frac{1}{2}$ " long
10	514V.106	Main Body	21	155/0408	$\frac{1}{4}$ " B.S.F. Socket Head Cap Screw, $\frac{1}{2}$ " long
11	514X.104A	Slider			

List of Parts for
PLATE No.12
(Drawing No.514Y1)

WHEN ORDERING SPARE PARTS ALWAYS QUOTE THE SERIAL NUMBER OF THE MACHINE

CHUCK OPERATING UNIT
6 $\frac{5}{8}$ "-6 AND 6 $\frac{5}{8}$ "-6D CHUCKING MACHINES

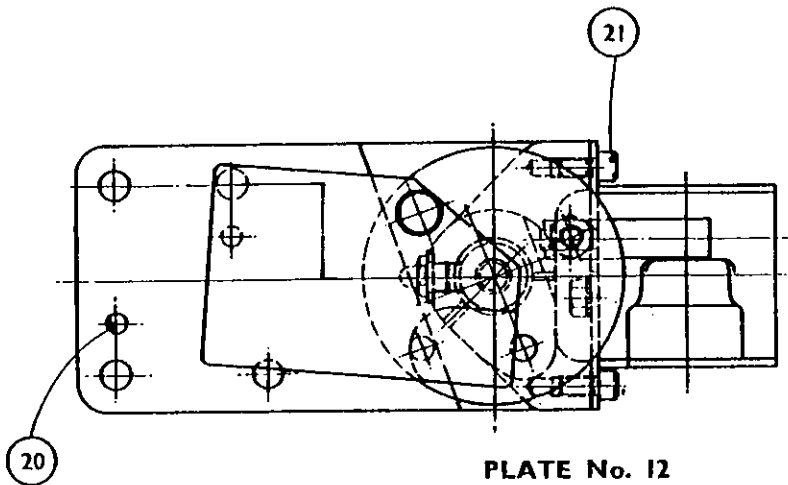
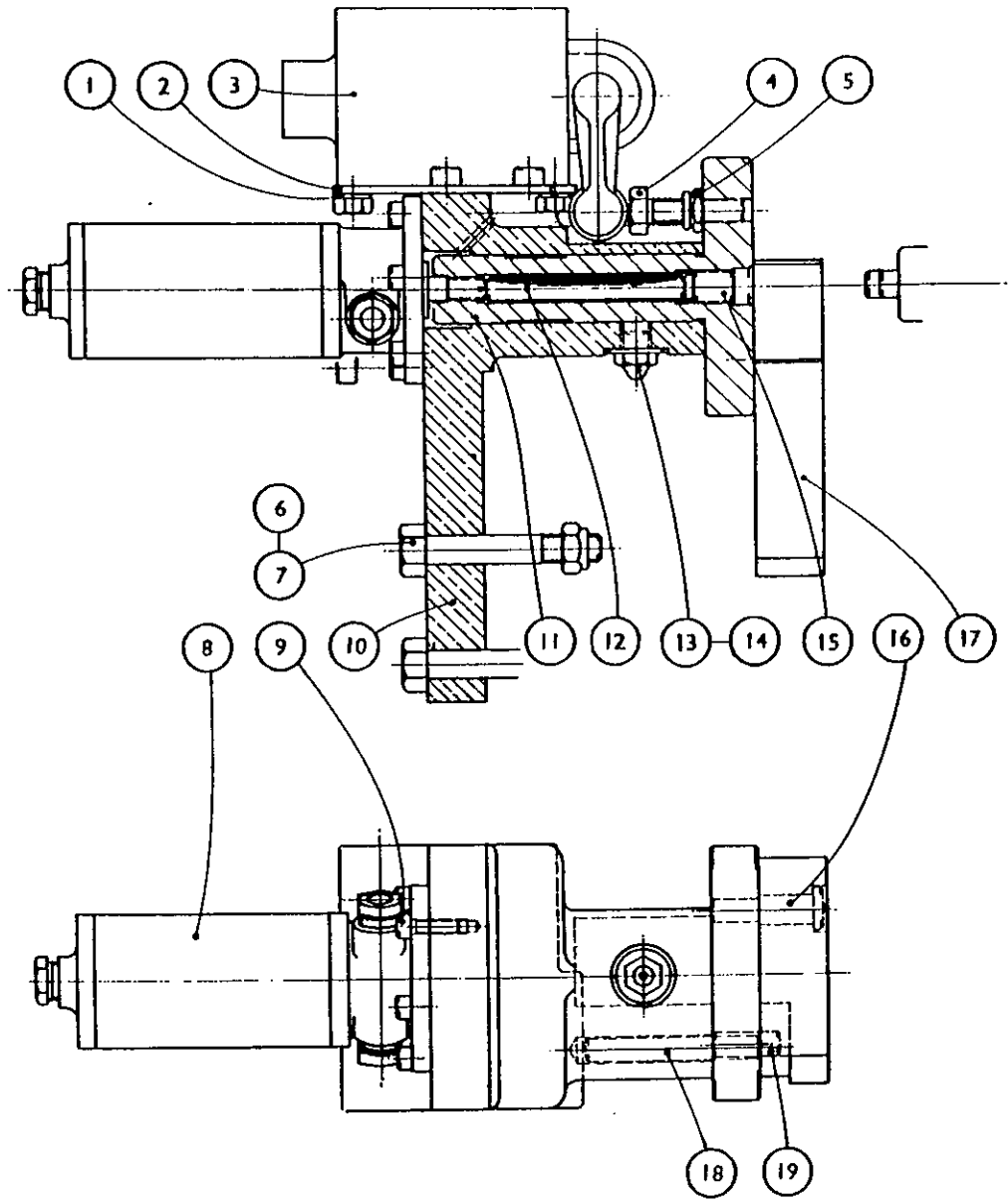

PLATE No. 12
(Drawing No. 514 Y 1)

214 Z 2A RELAY PANEL
6 1/2" - 6 MACHINE. SECTION 214B

**Commencing
Machine 11638
Last Used on
Machine 15093**

INDEX NO.	PART NO.	TITLE	INDEX NO.	PART NO.	TITLE
1	314X.125	Fault Nameplate	24	214Z.121B	Relay Panel
2	165/404	4BA Round Head Screw 1/4" long	25	326/0510	Spring Pin 3/32" x 3/8" long
3	291/67	Legend Plate 'SS7'	26	214X.11B	Cover Bolt
4	165/404	4BA Round Head Screw 1/4" long	27	130/06	Washer for 3/8" Dia.
5	162/410	4BA Counter Sunk Head Screw. 3/8" long	28	165/406	4BA Round Head Screw 3/8" long
6	203/4	4BA Self Locknut	29	174/4	Hexagon Nut 4BA
7	291/37	Legend Plate '2CR'	30	165/404	4BA Round Head Screw 1/4" long
8	165/404	4BA Round Head Screw 1/4" long	31	298A	Warning Plate
9		Marking Tag 'Klippon'	32		Terminal 'Klippon' SAK 2.5
10		End Section 'Klippon'	33		Screw Bolt and Screw SB 13
11	314X.144	Gasket	34		Jumper Bar (2 Pole) QL2
12	C16 A 239E	Multi - Step Switch, Single Pole, 12 Steps	35		Jumper Bar (4 Pole) QL4
13		Volcrepe Expanded 'RN' 1/4 x 1/2	36		Puc Tube 1/2" Internal Dia. x 27" long
14		End Bracket 'Klippon' Type EWK	37		Beta Strip 6mm
15	214X.160	Assembly Rail	38		Beta Buckle
16	291/75	Legend Plate 'FL'	39	165/206	2BA Round Head Screw 3/8" long
17	165/404	4BA Round Head Screw 1/4" long	40	198/6	Lockwasher for 2BA Dia.
18		Pilot Light Class 9001 TP 21R	41		Square 'D' Relay DO 40, Class 8501
19		Neoprene Packing 1/2" x 3/4"	42	291/36	Legend Plate '1 CR'
20	165/052B	5/16 B.S.F. Socket Cap Screw 1 1/4" long	43	165/404	4BA Round Head Screw 1/4" long
21	154/05	Spring Washer for 5/16" dia.	44		Beta Saddle
22		Square 'D' Relay DO 4Z, Class 8501	45	165/404	4BA Round Head Screw 1/4" long
23	162/204	2BA Counter Sunk Screw 1/4" long			

List Of Parts for
Plate No. 13
(Drawing No. 214 Z 2A)

WHEN ORDERING SPARE PARTS ALWAYS QUOTE THE INSPECTION NUMBER OF THE MACHINE

RELAY PANEL

6 1/4" - 6, 6 1/2" - 6D CHUCKING MACHINES

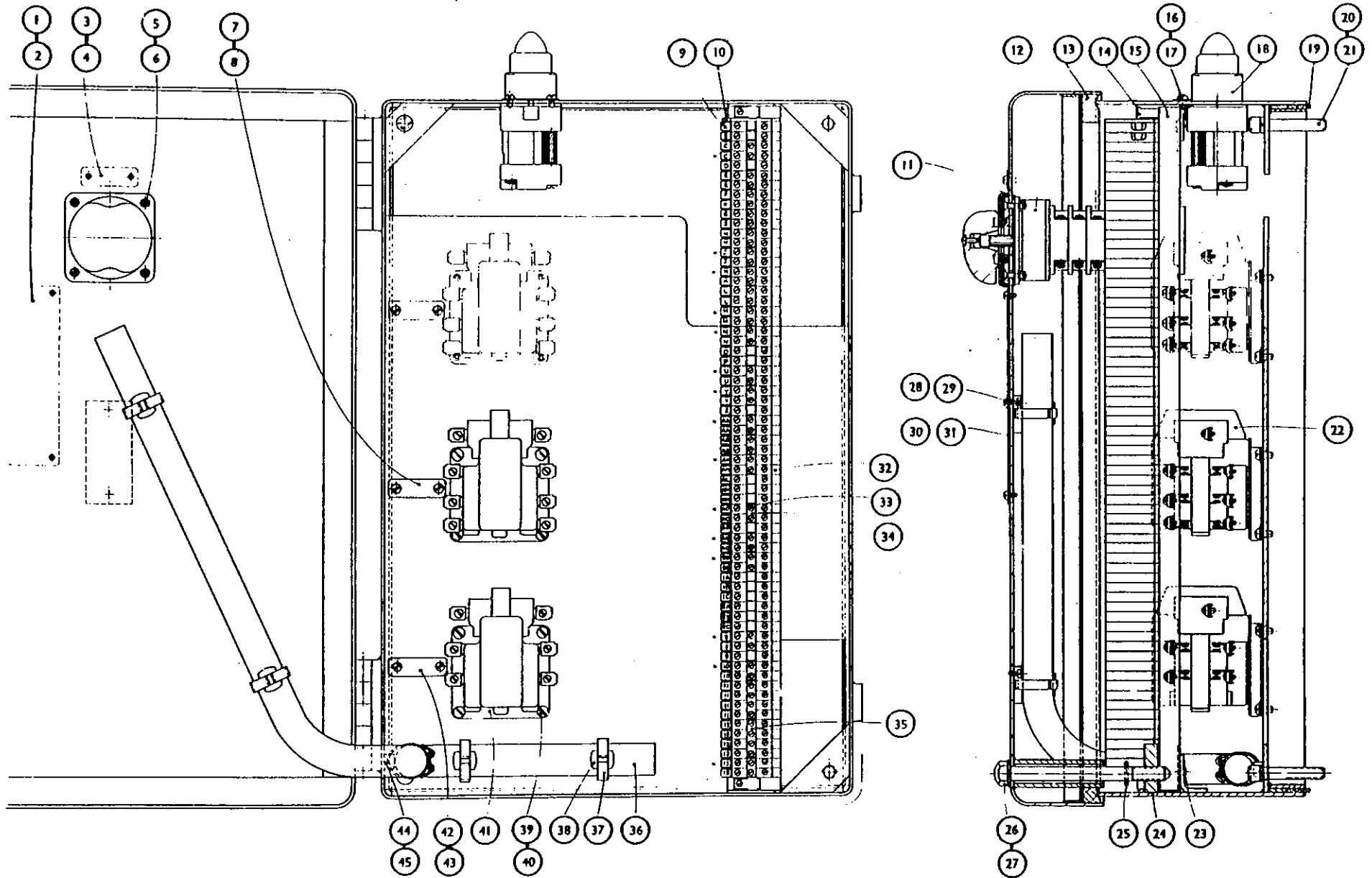

PLATE No.13
(Drawing No.214Z2A)

WICKMAN
MULTI-SPINDLE
AUTOMATICS

FRONT CONTROL PANEL
6 1/4" -6 CHUCKING MACHINE

Last Used On Machine No. 11694

INDEX NO.	PART NO.	TITLE	INDEX NO.	PART NO.	TITLE
1	514X.164	Gasket	17	154/05	Spring Washer
2	—	Edison 60V. 15 watt. Bulb	18	155/0514	5/16" B.S.F. Socket Head Cap Screw 3/8" long
3	15082	Indicator Unit	19	Type T.A.	Contact Block
4	514Y.140	Control Box Gasket	20	Type T.R.15	Push Button (Green)
5	214Y.139	Front Control Panel	21	Type T.A.	Contact Block
6	155/0512	5/16" B.S.F. Socket Head Cap Screw 1/2" long	22	Type T.R.2	Push Button (Red)
7	154/05	Spring Washer	23	160/204	2B.A. Socket Dome Head Screw
8	514X.113	Plug	24	214/V.143	Instruction Plate
9	514X.114	Washer	25	198/8	Shakeproof Washer
10	Type 777/1	Control Switch	26	167/0410	1/4" B.S.F. Hexagon Head Set Screw 3/8" long
11	514X.142A	Switch Lever	27	154/04	Spring Washer
12	241/8	Black Plastic Knob 1 1/2" dia. 5/16" B.S.F.	28	155/0412	1/4" B.S.F. Socket Head Cap Screw 1/2" long
13	514Z.138A	Front Control Box	29	194/4	1/4" B.S.P. Socket Pipe Plug
14	Type TA	Contact Block	30	240/4024	Hinge Type 207 2 1/2" long
15	Type TR.15	Push Button (Green)	31	159/208	2B.A. Socket Countersunk Head Screw 1/2" long
16	—	Cork	32	514X.181	Switch Lever

List of Parts for
PLATE No.14
(Drawing No.514V30)

WHEN ORDERING SPARE PARTS ALWAYS QUOTE THE SERIAL NUMBER OF THE MACHINE

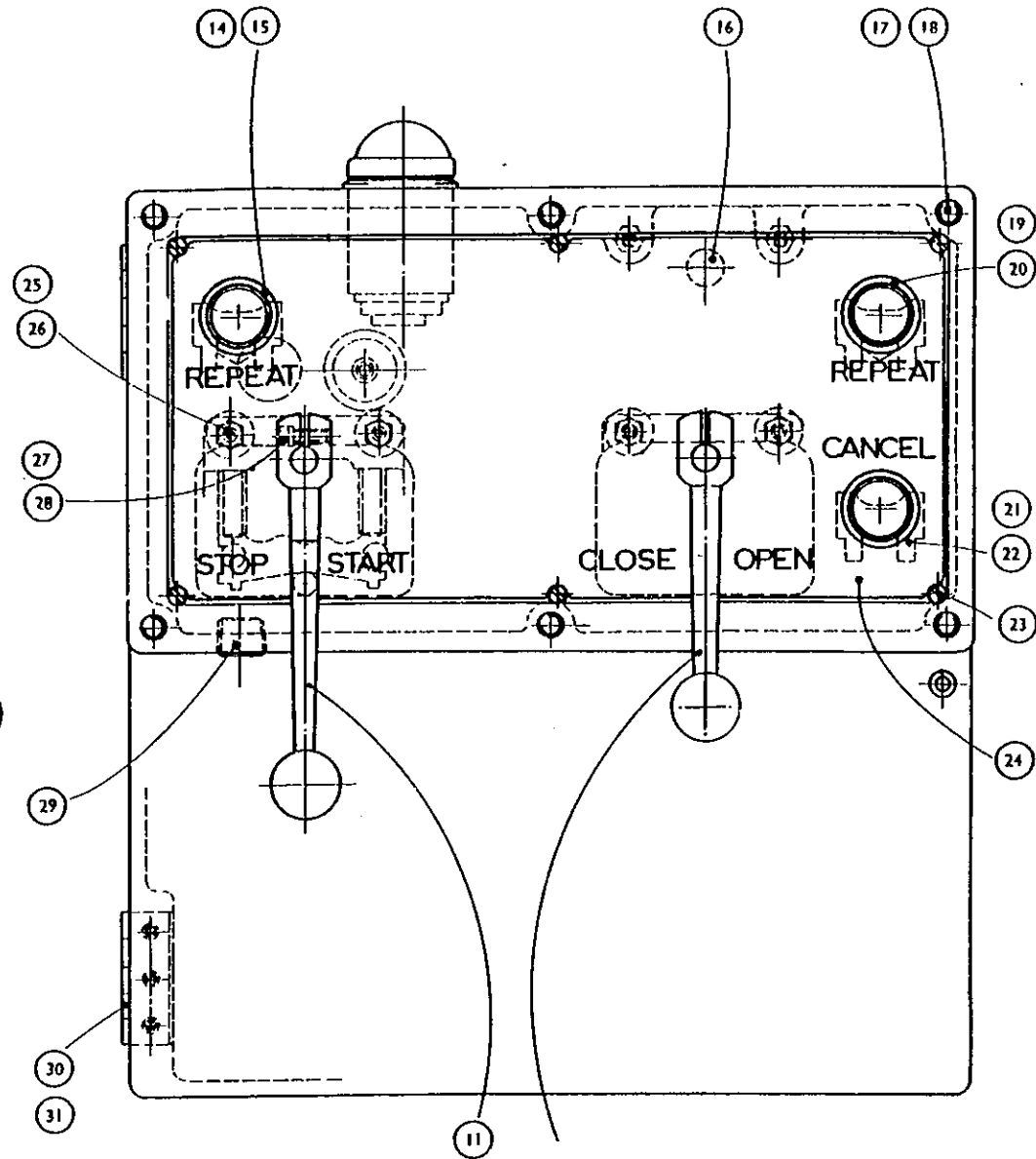
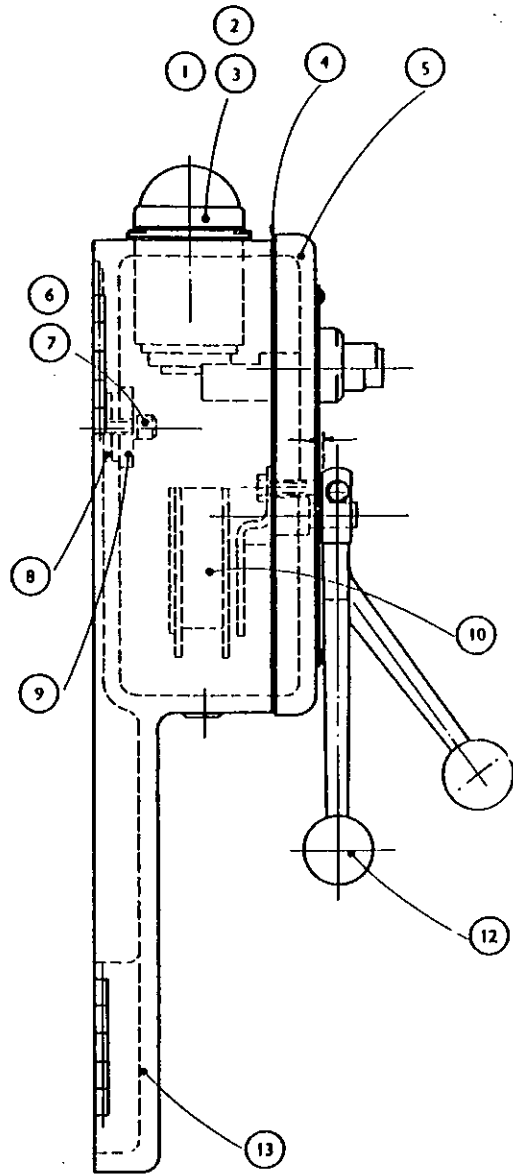

WICKMAN
MULTI-SPINDLE
AUTOMATICS

514 V 3D FRONT CONTROL PANEL
6 1/2" - 6 CHUCKING MACHINE. SECTION 514C

Last Used on
M/c No. 14711

INDEX NO.	PART NO.	TITLE
1	--	Colour Cap Red. Type RL-2 Square ' D'
2	--	Pilot Lamp TP-21. Square ' D'
3	514Y.140	Control Box Gasket
4	214Y.139A	Front Control Panel
5	--	Plastic Colour Cap. Green 66N Square ' D'
6	--	Contact Block Type TA Square ' D'
7	--	R.B. Operator Type TR 54 Square ' D'
8	--	Plug this hole on 7 1/4" - 6 and 9" - 4 Machines. Plug other Hole on 6 1/4" - 6 and 8" - 4 Machines
9	--	Cork to fit 11/16" dia. hole
10	165/0b28	5/16" BSF Socket Head Cap Screw 1 1/4" long
11	164/06	Spring Washer for 5/16" dia.
12	--	Plastic Colour Cap 66N Green. Square ' D'
13	--	Push Button Operator Type TR 54 Square ' D'
14	--	Contact Block Type TA. Square ' D'
15	--	Push Button Operator Type TR 54. Square ' D'
16	--	Plastic Colour Cap 6RD Red. Square ' D'
17	--	Contact Block Type TA. Square ' D'
18	160/204	2BA Socket Dome Head Screw 1/2" long
19	219V.143B	Instruction Plate
20	514X.181	Switch Lever
21	514X.142A	Switch Lever
22	159/208	2BA Socket Counter Sunk Head Screw 1/2" long
23	240/4024	Hinge Type 207. 2 1/2" long
24	514X.114	Washer
25	514X.113	Plug
26	155/0512	5/16" Socket Head Cap Screw 3/4" long
27	164/06	Spring Washer for 5/16" dia.
28	514Z.138A	Front Control Box
29	241/8	5/16" BSF Black Knob 1 1/4" Dia
30	194/4	1/2" BSP Socket Pipe Plug
31	214V.18	Relay Panel
32	154/04	Spring Washer for 1/2" dia.
33	165/0412	1/4" BSF Socket Head Cap Screw 3/4" long

List of Parts for
Plate No. 14A
(Drawing No. 514 V 3D)

WHEN ORDERING SPARE PARTS ALWAYS QUOTE THE INSPECTION NUMBER OF THE MACHINE

FRONT CONTROL PANEL
6 1/2" - 6 CHUCKING MACHINES

Last Used On
Machine No. 147 11

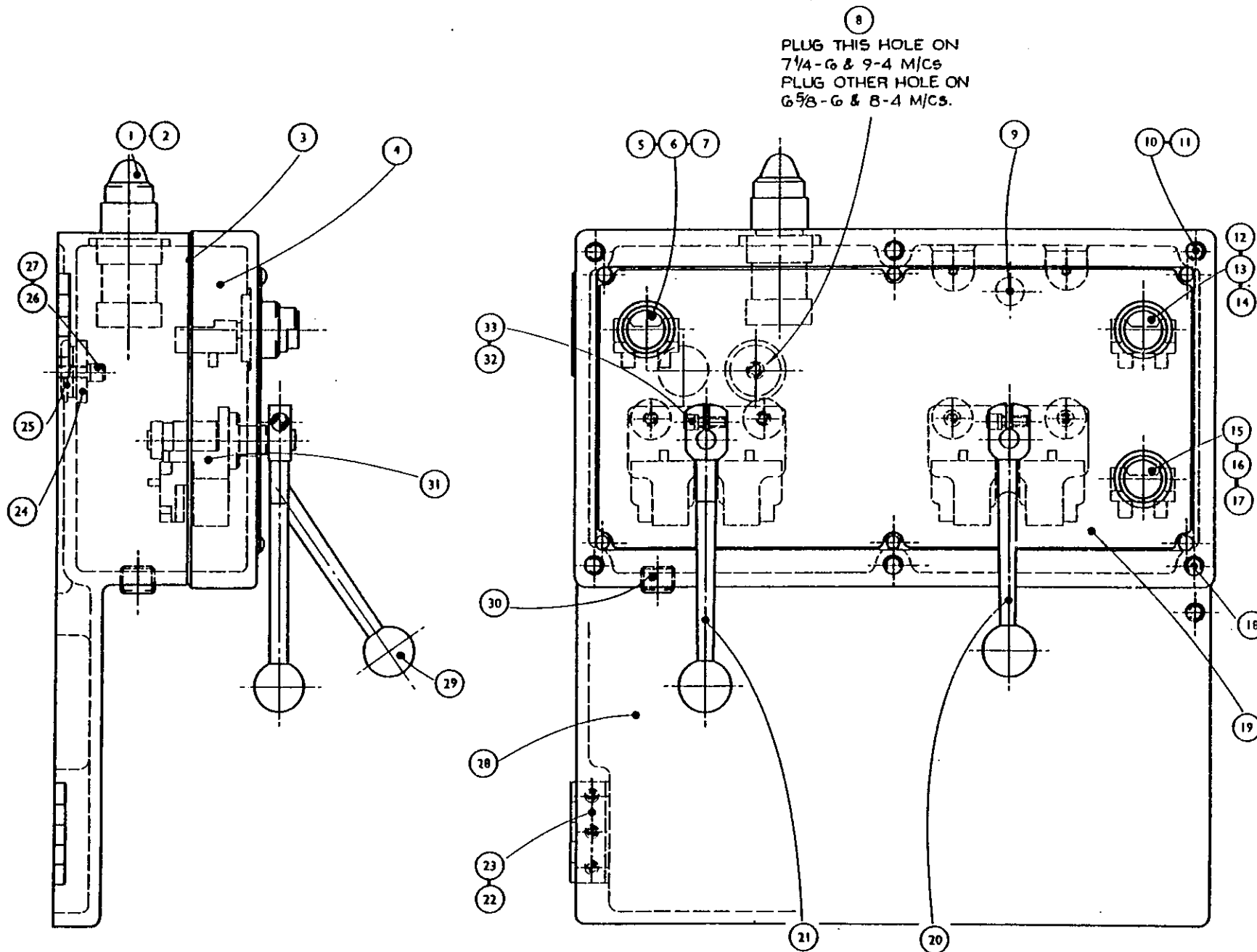

PLATE No. 14A
(Drawing No. 514V3D)

**SOLENOID OPERATED VALVE
6 $\frac{1}{8}$ "-6 AND 6 $\frac{1}{8}$ "-6D CHUCKING MACHINES**

INDEX NO.	PART NO.	TITLE.	INDEX NO.	PART NO.	TITLE.
1	203/4	4 B.A. Pinnacle Self-Locking Nut.	16	—	Maxam 4-way Pneumatic Valve.
2	514X.169	Pin.	17	127/0605	$\frac{1}{8}$ " dia. Split Cotter Pin.
3	174/2	2 B.A. Hex. Nut.	18	130/05	$\frac{1}{8}$ " Flat Washer.
4	203/2	2 B.A. Pinnacle Self-Locking Nut.	19	514X.167	Lever.
5	130/03	$\frac{1}{8}$ " Flat Washer.	20	514X.168	Link.
6	514X.170	Pin.	21	156/420	4 B.A. Socket Head Cap Screw, $1\frac{1}{4}$ " long.
7	514X.171A	Solenoid Plate.	22	130/03	$\frac{1}{8}$ " Flat Washer.
8	203/2	2 B.A. Pinnacle Self-Locking Nut.	23	203/2	2 B.A. Pinnacle Self-Locking Nut.
9	156/410	4 B.A. Socket Head Cap Screw, $\frac{1}{2}$ " long.	24	—	Metalastic Instrumounting 13/154/3.
10	154/4	4 B.A. Spring Washer.	25	176/0405	$\frac{1}{4}$ " B.S.F. Socket Set Screw, Cup Point, $\frac{1}{8}$ " long.
11	—	Two Way Terminal Block SN.5112 (Insulator).	26	153/04	$\frac{1}{2}$ " Soft Pad.
12	41/010	Wire, Type T.	27	514X.176	Stud.
13	—	Varley Solenoid, Type A, Pull-Type.	28	514X.174	Spacer.
14	154/04	$\frac{1}{2}$ " Spring Washer.	29	514V.172A	Solenoid Valve Base.
15	155/0444	$\frac{1}{2}$ " B.S.F. Socket Head Cap Screw, $2\frac{1}{2}$ " long.			

SOLENOID OPERATED VALVE
6 $\frac{1}{8}$ "-6 AND 6 $\frac{1}{8}$ "-6D CHUCKING MACHINES

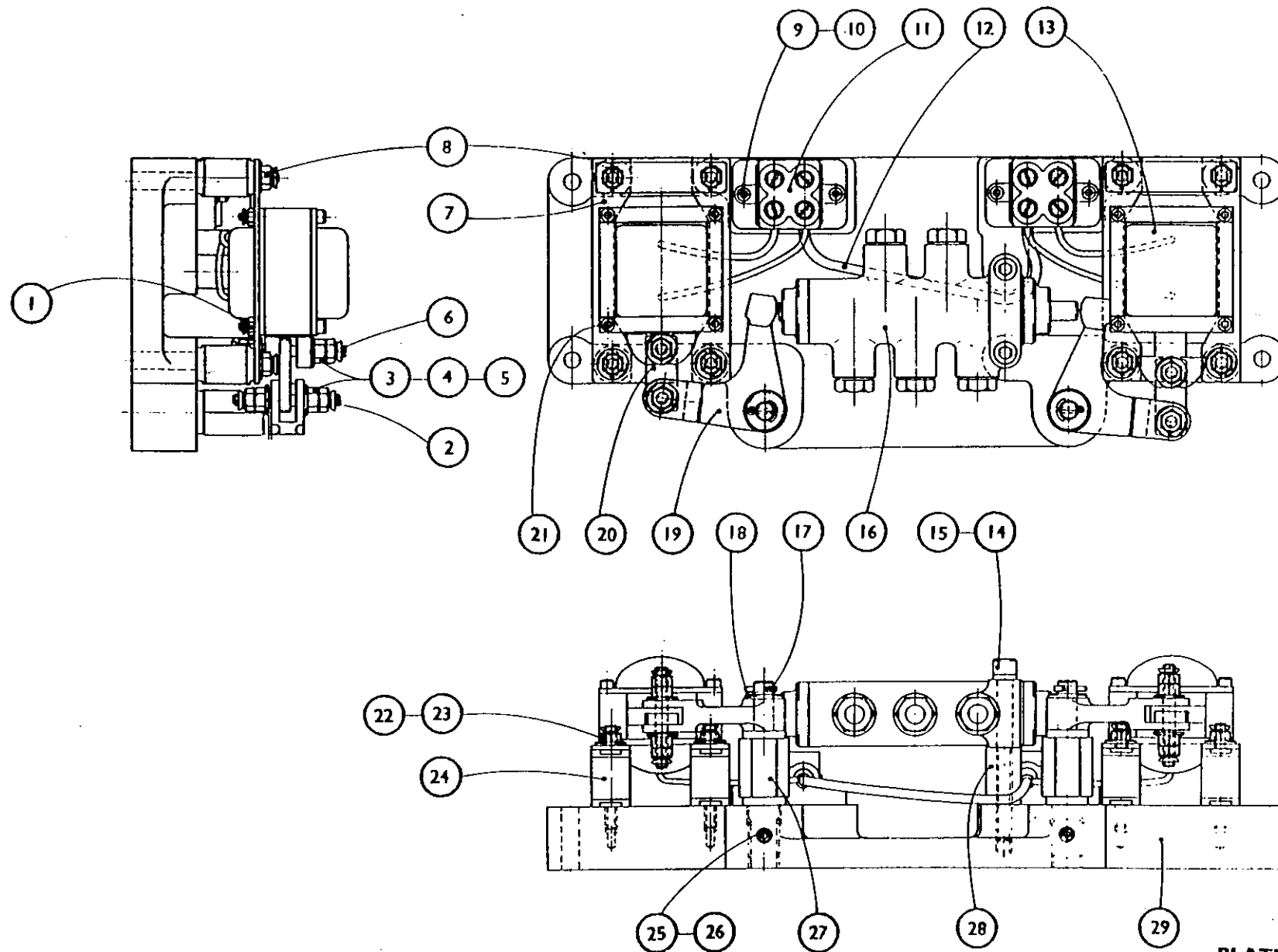

PLATE No. 15
(Drawing No. 514 Y 12)

**WICKMAN
MULTI-SPINDLE
AUTOMATICS**

**FRONT CONTROL PANEL
6 1/2" --6D CHUCKING MACHINE**

INDEX NO.	PART NO.	TITLE	INDEX NO.	PART NO.	TITLE
1	614X.164	Gasket	16	154/5	Spring Washer
2	—	Edison Screw Bulb 60v. 15 watt.	17	165/0514	5/16" B.S.F. Socket Head Cap Screw 7/8" long
3	15082	Crabtree Indicator Unit	18	614X.181	Switch Lever
4	614Y.140	Control Box Gasket	19	Type T.R.2	Push Button (Red)
5	214Y.139	Front Control Panel	20	Type T.A.	Contact Block
6	Type 777/1	Brookhirst Control Switch Single Pole	21	160/204	2 B.A. Socket Dome Head Screw 1/4" long
7	614X.142A	Switch Lever	22	214V.180	Instruction Plate
8	241/8	Black Plastic Knob 1 1/4" dia. 5/16" B.S.F.	23	198/8	Shakproof Washer
9	165/0512	5/16" B.S.F. Socket Head Cap Screw 3/4" long	24	167/0410	1/4" B.S.F. Hexagon Head Set Screw 3/4" long
10	164/05	Spring Washer	25	154/04	Spring Washer
11	614X.113	Plug	26	165/0412	1/4" B.S.F. Socket Head Cap Screw 3/4" long
12	614X.114	Washer	27	194/4	Socket Pipe Plug
13	614Z.138A	Front Control Box	28	240/4024	Hinge Type 207 2 1/2" long
14	Type T.R.16	Push Button (Green)	29	159/208	2 B.A. Socket Countersunk Head Screw 1/2" long
15	Type T.A.	Contact Block			

List of Parts for
PLATE No.16
(Drawing No.614V13A)

WHEN ORDERING SPARE PARTS ALWAYS QUOTE THE SERIAL NUMBER OF THE MACHINE

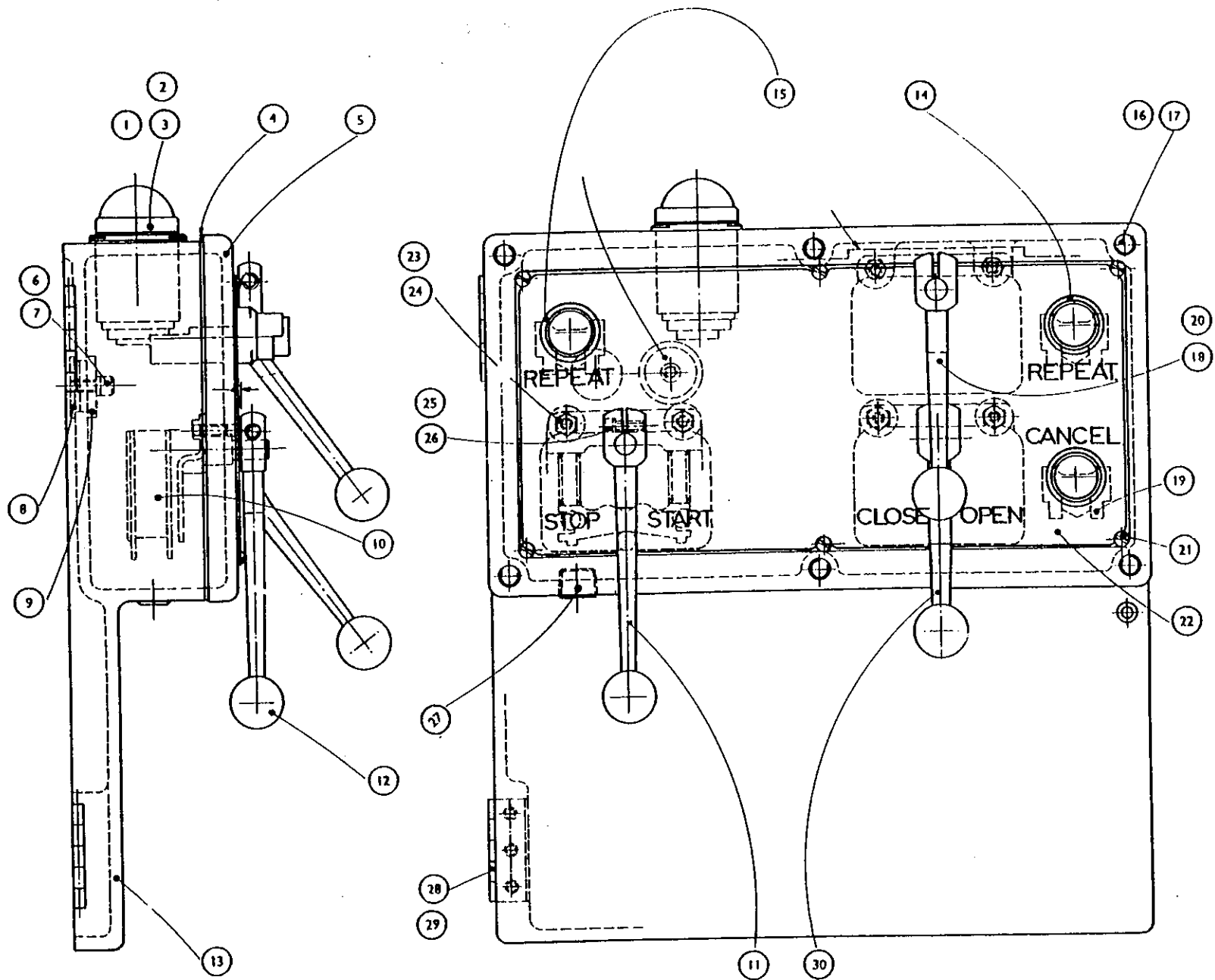

514 V 13C FRONT CONTROL PANEL
6 1/4" - 6D CHUCKING MACHINES. SECTION 514F

Last used on
 Machine 15360

INDEX NO.	PART NO.	TITLE
1	514X.114	Washer
2	514X.113	Plug
3	155/0512	5/16" BSF Socket Head Cap Screw 3/4" long
4	154/05	5/16" Spring Washer
5	Type RL-2	Colour Cap Red Square D
6	Type TP 21	Pilot Lamp Square D
7	514Y.140	Control Box Gasket
8	214Y.139A	Front Control Panel
9	Type T-6GN	Plastic Colour Cap Green Square D
10	Type TA	Contact Block Square D
11	Type TR 54	Push Button Operator Square D
12	514X.181	Switch Lever
13	155/0528	5/16" BSF Socket Head Cap Screw 1 1/2" long
14	154/05	5/16" Spring Washer
15	Type 6GN	Plastic Colour Cap Green Square D
16	Type TR 54	Push Button Operator Square D
17	Type TA	Contact Block Square D
18	Type TH 54	Push Button Operator Square D
19	Type 6RD	Plastic Colour Cap Red Square D
20	Type TA	Contact Block Square D
21	160/204	2BA Dome Head Screw 1/2" long
22	214V.180A	Instruction Plate
23	514X.181	Switch Lever
24	514X.142A	Switch Lever
25	169/208	2BA Socket Countersunk Head Screw 1/2" long
26	240/4024	Hinge Type 207 2 1/2" long
27	514Z.138A	Front Control Box
28	241/8	Black Plastic Knob 1 1/2" Dia. 5/16" BSF
29	194/4	1/2" BSP Socket Pipe Plug
30	214V.18	Control Switch
31	154/04	1/4" Spring Washer
32	155/0412	1/2" BSF Socket Head Cap Screw 3/4" long

List of Parts for
 Plate No.16A
 (Drawing No.514V13C)

WHEN ORDERING SPAHE PARTS ALWAYS QUOTE THE INSPECTION NUMBER OF THE MACHINE

FRONT CONTROL PANEL (DOUBLE INDEX MACHINES)

6 1/2" - 6D CHUCKING MACHINE

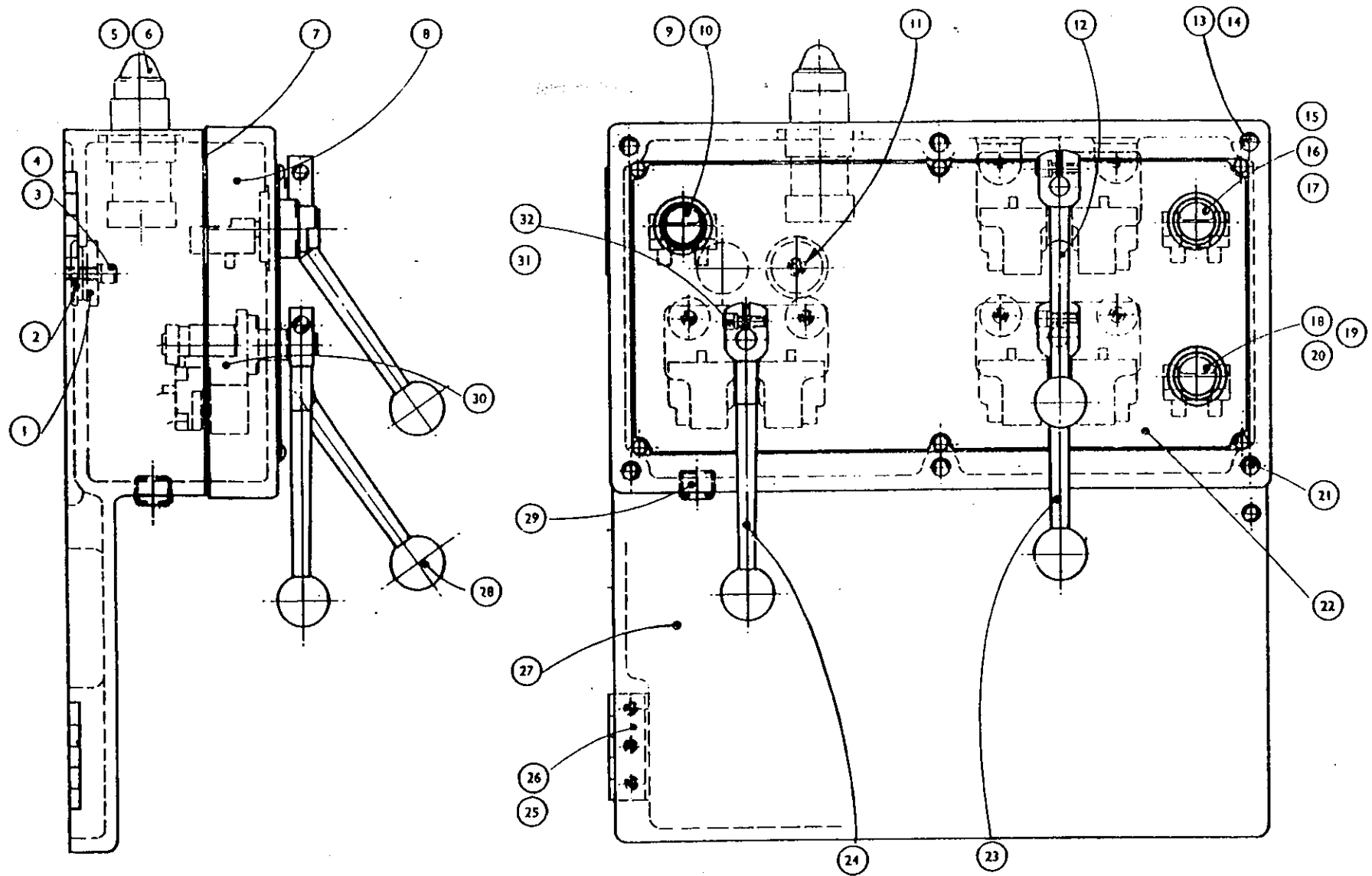

**WICKMAN
MULTI-SPINDLE
AUTOMATICS**

MOTOR DRIVE

2¼"-6, 2¼"-6D, 2"-6 AND 2"-6D BAR MACHINES
6⅝"-6, 6⅝"-6D CHUCKING MACHINES

INDEX NO.	PART NO.	TITLE.	INDEX NO.	PART NO.	TITLE.
1	322V.124	Belt Guard Back Plate.	19	316X.106	Adjustment Block.
2	322Y.121	Belt Guard Back Plate.	20	167/12160	⅜" B.S.F. Hexagon Head Set Screw, 10" long.
3	322Z.122B	Belt Guard.	21	316V.104A	Motor Platform Bracket.
4	322X.127	Belt Guard Spacer.	22	155/1280	⅜" B.S.F. Socket Head Cap Screw, 5" long.
5	322X.116	Belt Guard Stud.	23	154/12	⅜" Spring Washer.
6	203/06L	⅜" B.S.F. Simmonds Locknut.	24	188/0828	⅜" B.S.F. Square Head Set Screw, 1⅜" long.
7	316Y.102	Driven Pulley.	25	203/08	⅜" B.S.F. Self-Locking Nut.
8	C.96	Vee Belt, Type "C", ⅜" x ⅜" x 96" long.	26	316X.107	Spacer.
9	176/0612	⅜" B.S.F. Socket Set Screw, Cup Point, ⅜" long.	27	167/0612	⅜" B.S.F. Hexagon Head Set Screw, ⅜" long.
10	122/2072T	Tapped Key, ⅜" x ⅜" x 4½" long.	28	203/06L	⅜" B.S.F. Simmonds Locknut.
11	516X.105	Motor Platform Shaft.	29	172/110	Slotted Locknut, 110 mm.
12	316V.101A	Motor Pulley.	30	165/406	4 B.A. Round Head Screw, ⅜" long.
13	167/1040	⅜" B.S.F. Hexagon Head Set Screw, 2½" long.	31	203/4	4 B.A. Simmonds Locknut.
14	130/10	⅜" dia. Flat Washer.	32	197/11	⅜" Lockwasher.
15	316Y.103	Motor Platform.	33	167/0512	⅜" B.S.F. Hexagon Head Set Screw, ⅜" long.
16	173/12	⅜" B.S.F. Hexagon Nut.	34	167/0614	⅜" B.S.F. Hexagon Head Set Screw, ⅜" long.
17	155/0836	⅜" B.S.F. Socket Head Cap Screw, 2¼" long.	35	197/12	⅜" Lockwasher.
18	154/08	⅜" B.S.F. Spring Washer.			

List of Parts for
PLATE No. 17
(Drawing No. 316 Z 1)

WHEN ORDERING SPARE PARTS ALWAYS QUOTE THE SERIAL NUMBER OF THE MACHINE

MOTOR DRIVE

2¼"-6, 2¼"-6D, 2"-6 AND 2"-6D BAR MACHINES

6⅝"-6, 6⅝"-6D CHUCKING MACHINES

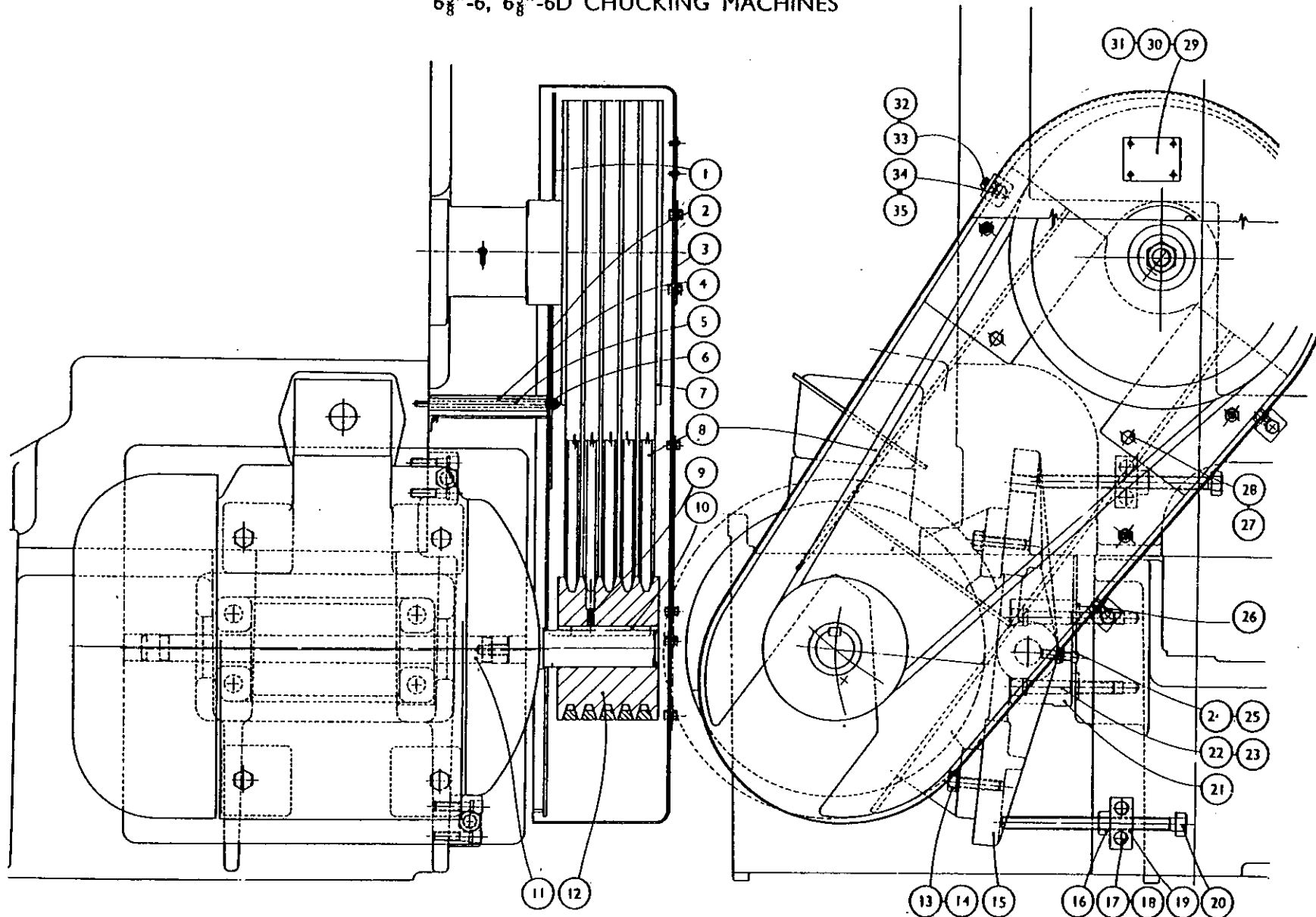

PLATE No. 17
(Drawing No. 316 Z 1)

316 Z 1B MOTOR DRIVE
6 $\frac{1}{4}$ "-6, 2"-6 MACHINES. SECTION 316

INDEX NO.	PART NO.	TITLE	INDEX NO.	PART NO.	TITLE
1	-	For U.S.A. and Canada: Brook Motor 1150 r.p.m. 25 h.p. Frame Size L324T	21	167/0612	Hexagon Head Set Screw, $\frac{3}{8}$ " B.S.F. x $\frac{1}{4}$ " long
		Brook Motor 1450 r.p.m. 25 h.p. Frame Size D180M	22	203/4	Selflocking Nut, 4 B.A. (Section 372)
		Totally enclosed, fan cooled. See 316 Y 103B for position	23	165/406	Round Head Screw, 4 B.A. x $\frac{3}{8}$ " long (Section 372)
2	322V.124	Belt Guard Back Plate	24	172X.110A	Motor Direction Check Plate (Section 372)
3	322Z.122B	Belt Guard	25	316X.107	Spacer
4	C96	Vee Belt, $\frac{7}{8}$ " x 17/32" x 96" inside length	26	188/0824	Square Head Set Screw, $\frac{1}{8}$ " B.S.F. x $1\frac{1}{4}$ " long
5	C100	Vee Belt, $\frac{7}{8}$ " x 17/32" x 100" inside length	27	203/08	Selflocking Nut, $\frac{1}{2}$ " B.S.F.
6	316Y.102	Driven Pulley	28	155/1280	Socket Head Cap Screw, $\frac{1}{2}$ " B.S.F. x 1" long
7	322X.127	Belt Guard Spacer	29	154/12	Spring Washer, for $\frac{3}{4}$ " dia.
8	322X.116	Belt Guard Stud	30	316V.104A	Motor Platform Bracket
9	203/06L	Selflocking Nut, $\frac{3}{8}$ " B.S.F.	31	167/12160	Hexagon Head Set Screw, $\frac{3}{8}$ " B.S.F. x 10" long
10	322 Y.121B	Belt Guard Back Plate	32	316X.106	Adjustment Block
11	316V.109B	Motor Pulley	33	155/0836	Socket Head Cap Screw, $\frac{1}{2}$ " B.S.F. x $2\frac{1}{4}$ " long
12	316Y.506A	Support Strip	34	154/08	Spring Washer, for $\frac{1}{2}$ " dia.
13	216X.106	Key, 14 mm x 9 mm x 100 mm long	35	173/12	Hexagon Nut, $\frac{3}{4}$ " B.S.F.
14	121/1664	Key, $\frac{1}{2}$ " square x 4" long	36	316Y.103B	Motor Platform
15	176/0612	Socket Cup Point Screw, $\frac{3}{8}$ " B.S.F. x $\frac{1}{2}$ " long	37	167/0828	Hexagon Head Set Screw, $\frac{1}{2}$ " B.S.F. x $1\frac{1}{2}$ " long
16	197/11	Shakeproof Washer, for 5/16" dia.	38	130/08	Flat Washer, for $\frac{1}{2}$ " dia.
17	167/0612	Hexagon Head Set Screw, 5/16" B.S.F. x $\frac{1}{2}$ " long	39	516X.105	Motor Platform Shaft
18	197/12	Shakeproof Washer, for $\frac{3}{8}$ " dia.			
19	167/0614	Hexagon Head Set Screw, $\frac{3}{8}$ " B.S.F. x $\frac{7}{8}$ " long			
20	203/06L	Selflocking Nut, $\frac{3}{8}$ " B.S.F.			

List of Parts for
Plate No. 17A
(Drawing No. 316 Z 1B)

WHEN ORDERING SPARE PARTS ALWAYS QUOTE THE INSPECTION NUMBER OF THE MACHINE

MOTOR DRIVE

2 1/4"-6, 2 1/4"-6D, 2"-6 AND 2"-6D BAR MACHINES

6 1/4"-6, 6 1/4"-6D CHUCKING MACHINES

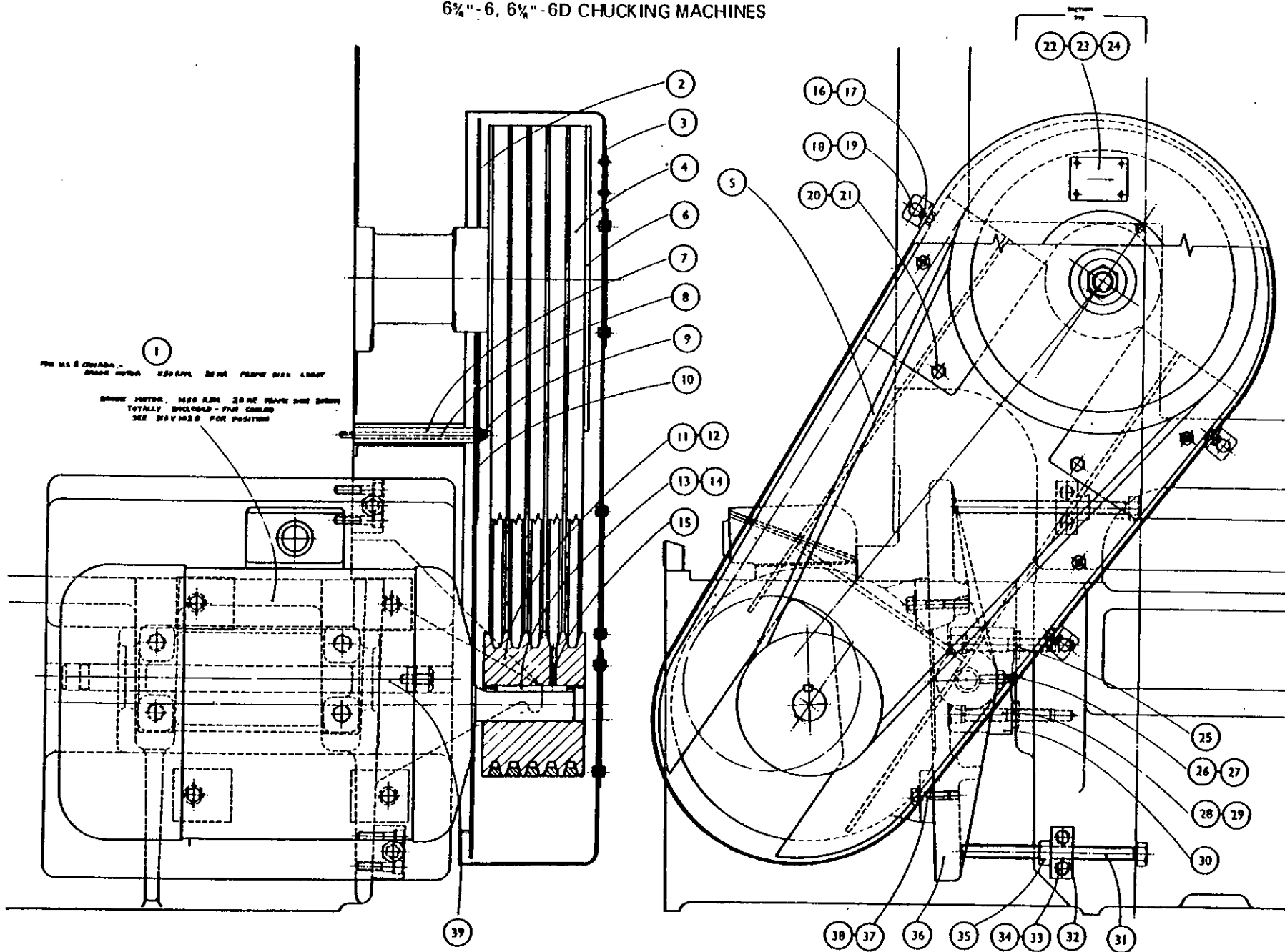

**WICKMAN
MULTI-SPINDLE
AUTOMATICS**

MAIN DRIVE GEARING

2 1/4" -6, 2 1/4" -6D AND 2" -6D BAR MACHINES

6 1/4" -6, 6 1/4" -6D CHUCKING MACHINES

INDEX NO.	PART NO.	TITLE	INDEX NO.	PART NO.	TITLE
1	164/06	3/4" Spring Washer	37	317X.185A	Key for 317Y.125
2	165/0620	3/8" B.S.F. Socket Head Cap Screw 1 1/4" long	38	203/16L	1" B.S.F. Self Locking Locknut
3	317X.138	Steady Bush	39	317X.116A	Clamp Washer
4	317Y.140A	Centre Drive Shaft	40	257/60	60mm x 130mm x 31mm Medium Bearing
5	317Y.141D	Centre Guide	41	317X.116A	Clamp Washer
6	103/39	85mm External Circlip	42	203/16L	1" B.S.F. Self Locking Locknut
7	317V.117A	Centre Guide Bearing	43	104/48	130mm Internal Circlip
8	194/1	1/4" B.S.P. Socket Pipe Plug	44	517Y.105A	Bearing Housing
9	104/52	150mm Internal Circlip	45	122/1622T	1/2" x 11/32" Parallel Tapped Key 1 1/4" long
10	258/85	85mm x 160mm x 28mm Light Bearing	46	122/1622T	1/2" x 11/32" Parallel Tapped Key 1 1/4" long
11	317X.115	Centre Shaft Coupler	47	257/65	65mm x 120mm x 29mm Medium Bearing
12	317X.114	Centre Shaft Spacer	48	317V.101A	Pulley Bearing Housing
13	317X.188	Key for 317Y.128	49		List of available Spindle Speed Gears
14	166/206	2BA Socket Head Cap Screw 3/8" long	50	154/05	5/16" Spring Washer
15	317X.193	Drive Sprocket	51	155/0516	5/16" B.S.F. Socket Head Cap Screw 1" long
16	258/85	85mm x 160mm x 28mm Light Bearing	52	317X.102	End Cap
17	104/52	150mm Internal Circlip	53	121/1662T	1/2" Square Parallel Tapped Key 3/4" long
18	317V.191	Bearing Housing	54	317X.116A	Clamp Washer
19	317X.143	Bearing Housing	55	203/16L	1" B.S.F. Self Locking Locknut
20	317X.107A	Clamp Plate	56	317X.151	Pulley Spacer
21	317X.192	Locking Pin	57	235/44562	2 1/2" x 3/4" x 3/8" Oil Seal
22	182/0408	1/4" B.S.F. Socket Set Screw 1/2" long. Taper Point	58	316Y.102	Drive Pulley
23	155/0612	3/8" B.S.F. Socket Head Cap Screw 3/4" long	59	317X.124A	Spacer
24	103/39	85mm External Circlip	60	154/10	3/8" Spring Washer
25	317Y.128	Centre Drive Shaft	61	155/1032	3/4" B.S.F. Socket Head Cap Screw 2" long
26	317V.147	Small Sliding Gear	62	317X.133	Coolant Pump Sprocket
27	317X.139A	Drive Pinion	63	317X.123	Spacer
28	317X.190A	Drive Pinion	64	317X.134	Oil Pump Sprocket
29	103/31	60mm External Circlip	65	258/60	60mm x 110mm x 62mm Light Bearing
30	104/48	130mm Internal Circlip	66	203/07L	7/16" B.S.F. Self Locking Locknut
31	155/0616	1/2" B.S.F. Socket Head Cap Screw 1" long	67	130/07	7/16" Flat Washer
32	517Y.105A	Bearing Housing	68	168X.133	Pump Sprocket
33	122/1632T	1/2" x 11/32" Parallel Tapped Key 2" long	69	110038	72 Link Renolds Chain
34	257/60	60mm x 130mm x 31mm Medium Bearing	70	168X.136	Pump Locknut
35		See Table	71	176/0405	1/4" B.S.F. Socket Set Screw 5/16" long. Cup Point
36	155/0408	1/4" B.S.F. Socket Head Cap Screw 1 1/2" long			

Continued.....

List of Parts for
PLATE No.18
(Drawing No.317Z1)

WHEN ORDERING SPAHE PARTS ALWAYS QUOTE THE INSPECTION NUMBER OF THE MACHINE

317 Z 1 ARRANGEMENT OF MAIN DRIVE GEARING

6 $\frac{1}{2}$ "-6, 6 $\frac{1}{2}$ "-6D, 2"-6 MACHINES. SECTION 317

INDEX NO.	PART NO.	TITLE
71	176/0405	Socket Set Screw, Cup Point, $\frac{1}{4}$ " B.S.F. x $\frac{5}{16}$ " long)
72	168X.134A	Eccentric Bush) Section 368
73	153/04	Soft Pad, for $\frac{1}{4}$ " B.S.F.)
74	118X.141	Spring Retaining Plug
75	317X.111	Clutch Spring
76	117X.152	Plunger
77	117X.152	Plunger
78	317X.111	Clutch Spring
79	118X.141	Spring Retaining Plug
80	--	See Drawing 168 Z 1A for Arrangement of Lubrication Pump
81	--	Enlarged Section of Plunger & Slipping Clutch Centre, Scale 4:1
82	317X.108	Thrust Washer
83	236/404840	Oil Retaining Bush, 2 $\frac{1}{2}$ " x 3" x 2 $\frac{1}{2}$ "
84	317V.135	Fast Motion Gear
85	317Y.104	Slipping Clutch Body
86	121/1244T	Key, Tapped, $\frac{1}{4}$ " square x 2 $\frac{3}{4}$ " long
87	317X.146	High Speed Drive Gear
88	317Y.122	Pulley Shaft
89	317X.120	Slow Speed Drive Gear
90	317X.130	Spacing Washer
91	257/45	Medium Journal, 45 x 100 x 25mm
92	317X.126	Clamp Washer
93	203/16L	Selflocking Nut, 1" B.S.F.
94	317X.136A	Slipping Clutch Centre
95	155/0824	Socket Head Cap Screw, $\frac{1}{2}$ " B.S.F. x 1 $\frac{1}{2}$ " long
96	154/08	Spring Washer, for $\frac{1}{2}$ " dia.
97	317Y.125	Speed Change Shaft
98	257/45	Medium Journal, 45 x 100 x 25mm
99	317X.126	Clamp Washer
100	203/16L	Selflocking Nut, 1" B.S.F.
101	317X.130	Spacing Washer
102	125/4036	Solid Taper Pin, $\frac{5}{8}$ " dia. x 2 $\frac{1}{4}$ " long
103	317X.110	Gear Centre
104	317V.148	Large Sliding Gear

List of Parts for
Plate No. 18
(Drawing No. 317Z 1)

WHEN ORDERING SPARE PARTS ALWAYS QUOTE THE INSPECTION NUMBER OF THE MACHINE

MAIN DRIVE GEARING
 2 1/4"-6, 2 1/4"-6D, 2"-6 AND 2"-6D BAR MACHINES
 6 3/8"-6, 6 3/8"-6D CHUCKING MACHINES

49

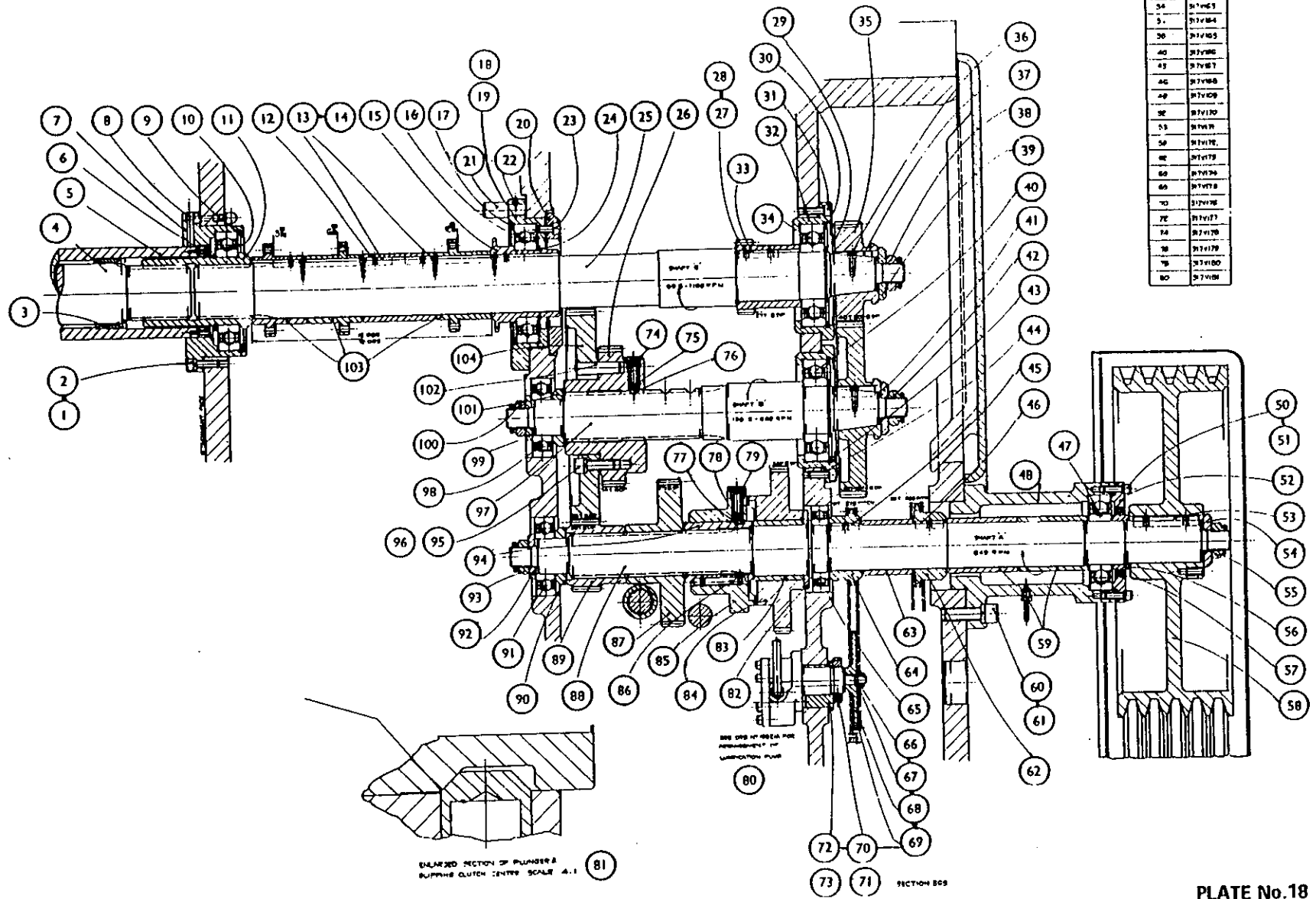

LIST OF MATERIAL	
SHAFTS	
QTY	DESCRIPTION
18	317V40
28	317V40
30	317V40
32	317V42
34	317V43
35	317V44
36	317V45
40	317V46
43	317V47
46	317V48
49	317V49
52	317V50
55	317V51
58	317V52
60	317V53
63	317V54
66	317V55
69	317V56
72	317V57
75	317V58
78	317V59
81	317V60
84	317V61

**WICKMAN
MULTI-SPINDLE
AUTOMATICS**

FEED DRIVE GEARING
2 $\frac{1}{4}$ "-6; 2 $\frac{1}{4}$ "-6D, 2"-6 AND 2"-6D BAR MACHINES
6 $\frac{5}{8}$ "-6 AND 6 $\frac{5}{8}$ "-6D CHUCKING MACHINES

Last Used On
M/c No.14704 - 6 $\frac{5}{8}$ "-6
M/c No.15752 - 2 $\frac{1}{4}$ "-6

INDEX NO.	PART NO.	TITLE.
1	318Y.125	Upper Wormwheel.
2	318Y.138	Upper Wormshaft.
3	318X.117A	Bearing Housing.
4	SB.22	Medium Angular Contact Bearing.
5	215/3	Tubing Nut.
6	318X.114	Bearing Cap.
7	318X.168	Wormshaft Sprocket
8	318X.167	Clutch Member.
9	317X.126	Clamp Washer.
10	203/16L	1" B.S.F. Self-Locking Nut (Thin).
11	155/0644	$\frac{1}{2}$ " B.S.F. Skt. Hd. Cap Screw, 2 $\frac{1}{2}$ " lg.
12	154/06	$\frac{1}{2}$ " Spring Washer.
13	318X.207	Jockey Sprocket Assembly.
14	318X.163	Jockey Eccentric.
15	518X.201	Key.
16	159/408	4 B.A. Skt. Ctsk. Hd. Screw, $\frac{1}{2}$ " lg.
17	103/21	35 mm. External Circlip.
18	258/35	Light Ball Journal, 35 x 72 x 17 mm.
19	215/3	Tubing Nut.
20	155/0620	$\frac{1}{2}$ " B.S.F. Skt. Hd. Cap Screw, 1 $\frac{1}{2}$ " lg.
21	154/06	$\frac{1}{2}$ " Spring Washer.
22	318X.101	Bearing Housing.
23	104/36	72 mm. Internal Circlip.
24	518X.148	Washer.
25	203/12L	$\frac{3}{4}$ " B.S.F. Self-Locking Nut (Thin).
26	104/38	80 mm. Internal Circlip.
27	103/21	35 mm. External Circlip.
28	518X.201	Key.
29	159/408	4 B.A. Skt. Ctsk. Hd. Screw, 1 $\frac{1}{2}$ " lg.
30	518X.148	Washer.
31	203/12L	$\frac{3}{4}$ " B.S.F. Self-Locking Nut (Thin).
32	257/35	Medium Ball Journal, 35x80x21 mm.
33	318X.103	Bearing Housing.
34	215/3	Tubing Nut.
35	154/06	$\frac{1}{2}$ " Spring Washer.
36	155/0620	$\frac{1}{2}$ " B.S.F. Skt. Hd. Cap Screw, 1 $\frac{1}{2}$ " lg.
37	154/06	$\frac{1}{2}$ " Spring Washer.
38	155/0620	$\frac{1}{2}$ " B.S.F. Skt. Hd. Cap Screw, 1 $\frac{1}{2}$ " lg.
39	318V.107	Bearing Housing.
40	121/1232T	$\frac{1}{2}$ " Tapped Key, 2" long.
41	318X.205	Bearing Cap.
42	318X.111	Washer.
43	257/35	Medium Ball Journal 35 x 80 x 21 mm.
44	203/16L	1" B.S.F. Self-Locking Nut (Thin).
45	318X.203	Oil Bush.
46	181AX.126	Oil Nipple.
47	219/17	$\frac{1}{2}$ " Male Elbow Adaptor.
48	155/0620	$\frac{1}{2}$ " B.S.F. Skt. Hd. Cap Screw, 1 $\frac{1}{2}$ " lg.
49	154/06	$\frac{1}{2}$ " Spring Washer.
50	155/0620	$\frac{1}{2}$ " B.S.F. Skt. Hd. Cap Screw, 1 $\frac{1}{2}$ " lg.
51	154/06	$\frac{1}{2}$ " Spring Washer.
52	360X.132	Output Gear (6 $\frac{1}{2}$ "-6D only).
53	318X.193	Output Gr. (2 $\frac{1}{2}$ "-6, 2"-6 & 6 $\frac{1}{2}$ "-6 only).
54	155/0620	$\frac{1}{2}$ " B.S.F. Skt. Hd. Cap Screw, 1 $\frac{1}{2}$ " lg.
55	154/06	$\frac{1}{2}$ " Spring Washer.
56	121/1228T	$\frac{1}{2}$ " Square Tapped Key, 1 $\frac{1}{2}$ " long.
57	317X.126	Clamp Washer.

INDEX NO.	PART NO.	TITLE.
58	203/16L	1" B.S.F. Self-Locking Nut (Thin).
59	168X.160	Oil Bush.
60	181AX.126	Oil Nipple.
61	318X.204A	Oil Bracket.
62	318X.165	Driving Sprocket.
63	218X.203	Pillar.
64	203/06	$\frac{3}{4}$ " B.S.F. Self-Locking Nut.
65	130/06	$\frac{1}{2}$ " Flat Washer.
66	318X.206	Bearing Clamp.
67	318V.153	Bearing Housing.
68	318X.157	Adjustment Ring.
69	257/35	Medium Ball Journal, 35 x 80 x 21 mm.
70	318X.155	Collar.
71	104/38	80 mm. Internal Circlip.
72	121/1232T	$\frac{1}{2}$ " Square Tapped Key, 2" long.
73	258/40	Light Ball Journal, 40 x 80 x 18 mm.
74	104/38	80 mm. Internal Circlip.
75	318V.170A	Gear.
76	360V.131	Gear (6 $\frac{1}{2}$ "-6D only).
77	101/44	5" dia. External Circlip.
78	318X.143	Inner Spacer.
79	318V.136	Clutch Sleeve.
80	258/40	Light Ball Journal, 40 x 80 x 18 mm.
81	318X.109	Thrust Collar.
82	318X.201	Clutch Key.
83	—	No. 5 Multigrip Clutch.
84	318Y.154	Feed Clutch Shaft.
85	318X.201	Clutch Key.
86	183/0828	$\frac{1}{2}$ " B.S.F. Square Head Screw, Taper Point, 1 $\frac{1}{2}$ " long.
87	203/08L	$\frac{1}{2}$ " B.S.F. Self-Locking Nut (Thin).
88	318V.166	Brake Housing.
89	257/50	Mdm. Ball Journal, 50 x 110 x 27 mm.
90	121/1232T	$\frac{1}{2}$ " Square Tapped Key, 2" long.
91	318X.196	Mitre Wheel.
92	318X.112	Washer.
93	203/12L	$\frac{3}{4}$ " B.S.F. Self-Locking Nut (Thin).
94	203/12L	$\frac{3}{4}$ " B.S.F. Self-Locking Nut (Thin).
95	318X.112	Washer.
96	318X.196	Mitre Wheel.
97	121/1228T	$\frac{1}{2}$ " Square Tapped Key, 1 $\frac{1}{2}$ " long.
98	318X.111	Washer.
99	203/16L	1" B.S.F. Self-Locking Nut (Thin).
100	194/1	$\frac{1}{2}$ " B.S.P. Socket Pipe Plug.
101	257/35	Medium Ball Journal, 35 x 80 x 21 mm.
102	318X.142	Collar.
103	104/42	100 mm. Internal Circlip.
104	101/43	4 $\frac{1}{2}$ " dia. External Circlip.
105	318V.192	Feed Input Gear.
106	203/12L	$\frac{3}{4}$ " B.S.F. Self-Locking Nut (Thin).
107	518X.148	Washer.
108	257/35	Medium Ball Journal 35 x 80 x 21 mm.
109	318Y.124	Lower Wormwheel.
110	318Y.137	Lower Wormshaft.
111	SB.7	Medium Angular Contact Bearing.
112	318X.158	Spacer.
113	318X.159	Spacer.

INDEX NO.	PART NO.	TITLE.
114	318X.113	Bearing Housing.
115	215/3	Tubing Nut.
116	318X.115	End Cap.
117	318X.195	Handwind Gear.
118	317X.126	Clamp Washer.
119	203/16L	1" B.S.F. Self-Locking Nut (Thin).
120	154/07	$\frac{1}{2}$ " Spring Washer.
121	155/0728	$\frac{1}{2}$ " B.S.F. Skt. Hd. Cap Screw, 1 $\frac{1}{2}$ " lg.
122	318V.132	Free Wheel Body.
123	—	$\frac{1}{2}$ " dia. Steel Roller, $\frac{1}{2}$ " long.
124	518X.221	Free Wheel Plunger.
125	518X.220	Free Wheel Spring.
126	203/16L	1" B.S.F. Self-Locking Nut (Thin).
127	318X.111	Washer.
128	257/35	Medium Ball Journal, 35 x 80 x 21 mm.
129	203/12	$\frac{3}{4}$ " B.S.F. Self-Locking Nut.
130	518X.197	Collar.
131	258/35	Light Ball Journal, 35 x 72 x 17 mm.
132	103/21	35 mm. External Circlip.
133	518X.201	Key.
134	159/408	4 B.A. Skt. Ctsk. Hd. Screw, $\frac{1}{2}$ " lg.
135	518X.148	Washer.
136	203/12L	$\frac{3}{4}$ " B.S.F. Self-Locking Nut (Thin).
137	318X.183	Gear.
138	318X.178	Gear (6 $\frac{1}{2}$ "-6D and 2 $\frac{1}{2}$ " - 6 L B F).
139	318X.145	Input Shaft.
140	318V.149	Intermediate Shaft.
141	318X.128	Slipping Clutch Centre.
142	122/1240T	Tapped Rectangular Key $\frac{1}{2}$ " x $\frac{1}{4}$ " x 2 $\frac{1}{2}$ ".
143	318Y.127B	Slipping Clutch Body.
144	117X.152	Plunger.
145	117X111A	Clutch Spring.
146	118X.141	Spring Retaining Plug.
147	318X.130	Slipping Clutch Gear.
148	236/242836	Oil Retaining Bush.
149	318X.122	Thrust Collar.
150	121/1232T	$\frac{1}{2}$ " Square Tapped Key, 2" long.
151	121/1232T	$\frac{1}{2}$ " Square Tapped Key 2" long.
152	318X.201	Clutch Key.
153	121/1244T	$\frac{1}{2}$ " Square Tapped Key, 2 $\frac{1}{2}$ " long.
154	318Y.151	Fast Motion Clutch Shaft.
155	318X.201	Clutch Key.
156	318X.109	Thrust Collar.
157	258/40Z	Light Ball Journal, 40 x 80 x 18 mm.
158	318X.108	Inner Spacer.
159	273/40Z	Light Roller Journal, 40x80x18mm.
160	104/38	80 mm. Internal Circlip.
161	318X.110	Outer Spacer.
162	318V.135	Clutch Gear.
163	—	No. 5 Multigrip Clutch.
164	258/55Z	Light Ball Journal, 55 x 100 x 21 mm.
165	318X.133	Side Plate.
166	318V.131	Clutch Cup.
167	257/40	Medium Ball Journal 40x90x23mm.
168	—	Duplex Roller Chain, 114046, 100 pitches.

List of Parts for
PLATE No. 19
(Drawing No. 318 Z I)

WHEN ORDERING SPAKE PARTS ALWAYS QUOTE THE SERIAL NUMBER OF THE MACHINE

FEED DRIVE GEARING
 2 1/4"-6, 2 1/4"-6D, 2"-6 AND 2"-6D BAR MACHINES
 6 5/8"-6 AND 6 5/8"-6D CHUCKING MACHINES

Last Used On
 Machine No.14704 - 6 1/2" - 6
 Machine No.15752 - 2 1/4" - 6

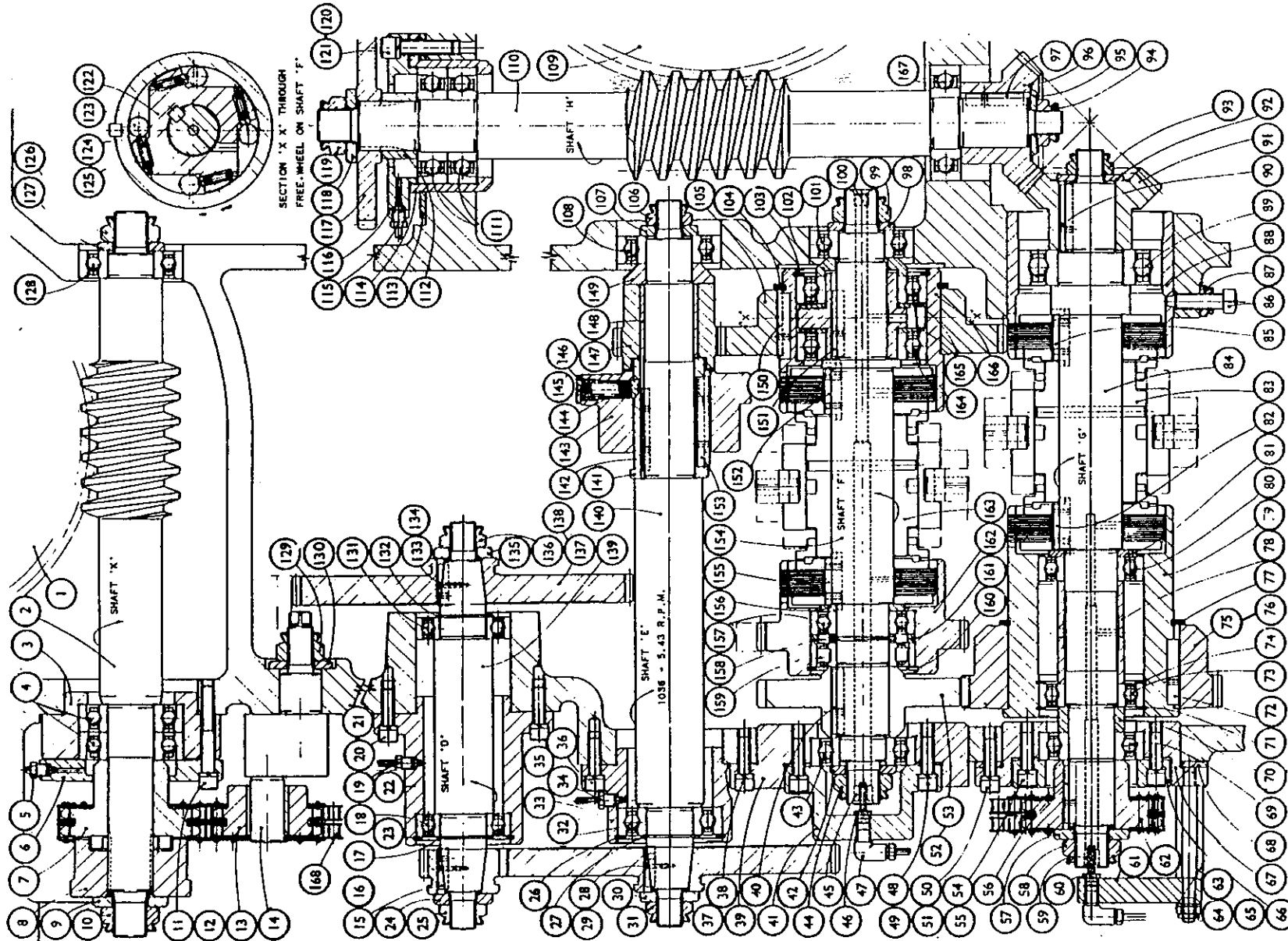

LIST OF AVAILABLE FEED GEARS 8DP. 20° P.A.

Drg. Ref. No.	Drg. Ref. No.	Drg. Ref. No.	Drg. Ref. No.
19T. 518X171	37T. 518X177	52T. 518X182	70T. 318X179
21T. 318X171	39T. 518X178	55T. 318X173	72T. 318X180
24T. 518X172	42T. 518X179	57T. 318X174	75T. 318X181
27T. 518X173	44T. 518X180	60T. 318X175	78T. 318X182
29T. 518X174	47T. 518X181	62T. 318X176	81T. 318X183
32T. 518X175	49T. 318X184	65T. 318X177	
34T. 518X176	50T. 318X172	67T. 318X178	

List of Parts for
PLATE No. 19
 (Drawing No. 318 Z 1)

318 Z 2A ARRANGEMENT OF ELECTRO-MAGNETIC CLUTCH AND FEED BRAKE FOR FEED DRIVE

2 1/4"-6, 6 1/2"-6 MACHINE. SECTION 318

COMMENCING ON
 INSP. No. 15753 2 1/4 - 6
 INSP. No. 15361 6 1/2 - 6

INDEX NO.	PART NO.	TITLE	INDEX NO.	PART NO.	TITLE
1	518X.220	Freewheel spring	37	154/07	Spring Washer, for 7/16" dia.
2	518X.221	Freewheel Plunger	38	318X.113	Bearing Housing
3	-	Roller, 3/8" dia.	39	587	Medium Angular Contact Bearing, 40 x 90 x 23mm
4	318V.132	Freewheel Body	40	318Y.137	Lower Wormshaft
5	101/21	External Circlip, 35mm	41	318Y.124	Lower Wormwheel
6	159/408	Countersunk Head Screw, 4 B.A. x 1/2" long	42	518X.148	Washer
7	518X.201	Key	43	203/12L	Selflocking Nut, Thin, 3/4" B.S.F.
8	518X.148	Washer	44	318V.192	Feed Inout Gear
9	203/12L	Selflocking Nut, 3/4" B.S.F.	45	121/1232T	Key, Tapped, 3/8" square x 2" long
10	-	See Table on 318 Z 3	46	101/43	External Circlip, 4 1/4" dia.
11	104/38	Internal Circlip, 80mm	47	318X.133	Side Plate
12	257/35	Medium Metric Journal, 35 - 80 - 21mm	48	104/42	Internal Circlip, 100mm
13	215/3	Tubing Nut, for 3/16" o.d. tube (Section 368)	49	318X.142	Collar
14	154/06	Spring Washer, for 3/4" dia.	50	257/36	Medium Metric Journal, 35 - 80 - 21mm
15	165/0x 20	Socket Head Cap Screw, 3/8" B.S.F. x 1 1/4" long	51	318X.111	Washer
16	318X.103	Bearing Housing	52	194/1	Socket Pipe Plug, 1/2" B.S.P.
17	318V.149	Intermediate Shaft	53	203/16L	Selflocking Nut, Thin, 1" B.S.F.
18	121/1244T	Key, Tapped, 3/8" square x 2 1/2" long	54	257/40	Medium Metric Journal, 40 - 90 - 23mm
19	318X.128	Slipping Clutch Centre	55	121/1228T	Key, Tapped, 3/8" square x 1 1/2" long
20	122/1240T	Key, Tapped, 3/8" x 1/4" x 2 1/2" long	56	318X.196	Mitre Wheel
21	318Y.127B	Slipping Clutch Body	57	318X.112	Washer
22	117X.152	Plunger	58	203/12L	Selflocking Nut, Thin, 3/4" B.S.F.
23	117X.111A	Clutch Spring	59	318Y.232A	Feed Clutch Shaft
24	118X.141	Spring Retaining Plug	60	318X.241	Mitre Wheel
25	318X.130	Slipping Clutch Gear	61	258/55	Light Metric Journal, 55 - 100 - 21mm
26	257/35	Medium Metric Journal, 35 - 80 - 21mm	62	318X.246	Clamp Ring
27	236/242836	Oil Retaining Bush, 1 1/2" x 1 1/4" x 2 1/4" long	63	155/0414	Socket Head Cap Screw, 1/2" B.S.F. x 3/4" long
28	318X.122	Thrust Collar	64	154/04	Spring Washer, for 1/2" dia.
29	318X.159	Spacer	65	176/0506	Socket Set Screw, 5/16" B.S.F. x 3/8" long
30	215/3	Tubing Nut, for 3/16" o.d. tube (Section 368)	66	163/05	Soft Pad, for 5/16" dia.
31	318X.115	End Cap	67	151/55	Slotted Locknut, 65mm
32	318X.195	Handwind Gear	68	139/16	Square Head Dowel, 3/8" dia. x 1 1/4" long
33	203/16L	Selflocking Nut, 1" B.S.F.	69	154/04	Spring Washer, for 1/2" dia.
34	317X.126	Clamp Washer	70	318X.251	Spring
35	318X.158	Spacer	71	155/0416	Socket Head Cap Screw, 1/2" B.S.F. x 1" long
36	155/0728	Socket Head Cap Screw, 7/16" B.S.F. x 1 1/4" long	72	318X.244	Adjustment Washer

List of Parts for
 Plate No. 19A
 (Drawing No. 318 Z 2A)

WHEN ORDERING SPARE PARTS ALWAYS QUOTE THE INSPECTION NUMBER OF THE MACHINE

318 Z 2A ARRANGEMENT OF ELECTRO-MAGNETIC CLUTCH AND FEED BRAKE FOR FEED DRIVE

2 1/4"-6, 6 3/8"-6 MACHINES. SECTION 318

COMMENCING ON
INSP. No. 15753 2 1/4 - 6
INSP. No. 15361 6 3/8 - 6

INDEX NO.	PART NO.	TITLE	INDEX NO.	PART NO.	TITLE
73	318X.245	Bobbin	111	318X.242	Clamp Plate
74	318V.238	Sliding Clutch	112	318V.234A	Bearing Housing
75	318Y.236	Clutch Sleeve	113	318V.107	Bearing Housing
76	103/30	External Circlip, 55mm	114	318X.111	Washer
77	318V.230A	Electro-Magnetic Clutch	115	203/16L	Selflocking Nut, Thin, 1" B.S.F.
78	268/50	Extra Light Metric Journal	116	318X.203	Oil Bush
79	126/0812	Parallel Dowel, 1/4" dia. x 1 1/2" long	117	318V.233A	Brake Mounting Body
80	318X.247	Spacer	118	181AX.126	Oil Nipple
81	103/42	External Circlip, 100mm	119	318X.205	Bearing Cap
82	318X.252	Outer Spacer	120	219/17	Elbow Adaptor, Male, 3/16" o.dia. Tube (Section 368)
83	318X.250	Inner spacer	121	257/35	Medium Metric Journal, 35 - 80 - 21mm
84	104/50	Internal Circlip, 140mm	122	-	Note: Fast motion input gear on shaft "A" see 317 Z 1
85	275/100	Extra Light Metric Journal, 100 - 140 - 20mm	123	154/06	Spring Washer, for 3/16" dia.
86	318V.237A	Gear, 61 Teeth (2 1/4" - 6 3/8" - 6)	124	155/0620	Socket Head Cap Screw, 3/8" B.S.F. x 1 1/4" long
87	318V.268	Gear, 75 Teeth (2 1/4" - 6L, 6 3/8" - 6D)	125	360X.192	Output Gear, 35 Teeth (2 1/4" - 6L, 6 3/8" - 6D)
88	318V.235A	Bearing Mounting Sleeve	126	318X.193	Output Gear, 49 Teeth (2 1/4" - 6, 6 3/8" - 6)
89	258/50	Light Metric Journal, 50 - 90 - 20mm	127	155/0620	Socket Head Cap Screw, 3/4" B.S.F. x 1 1/4" long
90	103/28	External Circlip, 50mm	128	154/06	Spring Washer, for 3/8" dia.
91	103/30	External Circlip, 55mm	129	318Y.151A	Fast Motion Clutch Shaft
92	155/0524	Socket Head Cap Screw, 5/16" B.S.F. x 1 1/2" long	130	121/1232T	Key, Tapped, 3/8" square x 2" long
93	154/05	Spring Washer, for 5/16" dia.	131	104/38	Internal Circlip, 80mm
94	101/18	External Circlip, 1 1/2" dia.	132	273/40Z	Light Metric Roller Journal, 40 - 80 - 18mm
95	258/55	Light Metric Journal, 55 - 100 - 21mm	133	318X.110	Outer Spacer
96	318X.259	Metric Key	134	318X.108	Inner Spacer
97	318X.240	Driving Sprocket	135	318X.109	Thrust Collar
98	169/0524	Hexagon Head Screw, 5/16" B.S.F. x 1 1/2" long	136	318X.201A	Clutch Key
99	198/11	Shakeproof Washer, for 5/16" dia.	137	318V.210	No. 5 Herber's Multi-Grip Double Clutch
100	104/36	Internal Circlip, 72mm	138	318X.201A	Clutch Key
101	273/35	Light Metric Roller Journal, 35 - 72 - 17mm	139	318X.202	Clutch Spring
102	318X.266A	Spacer	140	318V.135	Clutch Gear
103	130/14	Flat Washer, for 7/8" dia.	141	258/40Z	Light Metric Journal, 40 - 80 - 18mm
104	203/14L	Selflocking Nut, Thin, 3/4" B.S.F.	142	155/0408	Socket Head Cap Screw, 1/2" B.S.F. x 1/2" long
105	118V.231A	Electro-Magnetic Spring Brake	143	318X.260	Metric Key
106	118X.258	Metric Key	144	318V.131	Clutch Cup
107	155/0620	Socket Head Cap Screw, 3/8" B.S.F. x 1 1/4" long	145	121/1232T	Key, Tapped, 3/4" square x 2" long
108	155/0648	Socket Head Cap Screw, 3/4" B.S.F. x 3" long	146	258/55Z	Light Metric Journal, 55 - 100 - 21mm
109	154/06	Spring Washer, for 3/8" dia.	147	318X.248	Spring Abutment
110	155/0410	Socket Head Cap Screw, 1/2" B.S.F. x 5/8" long	148	318X.239	Bearing Housing

List of Parts for
Plate No. 19A
(Drawing No. 318 Z 2A)

WHEN ORDERING SPARE PARTS ALWAYS QUOTE THE INSPECTION NUMBER OF THE MACHINE

ELECTRO-MAGNETIC FEED CLUTCH & BRAKE

2 1/4"-6, 2 1/4"-6D BAR MACHINES. 6 1/2"-6, 6 1/2"-6D CHUCKING MACHINES

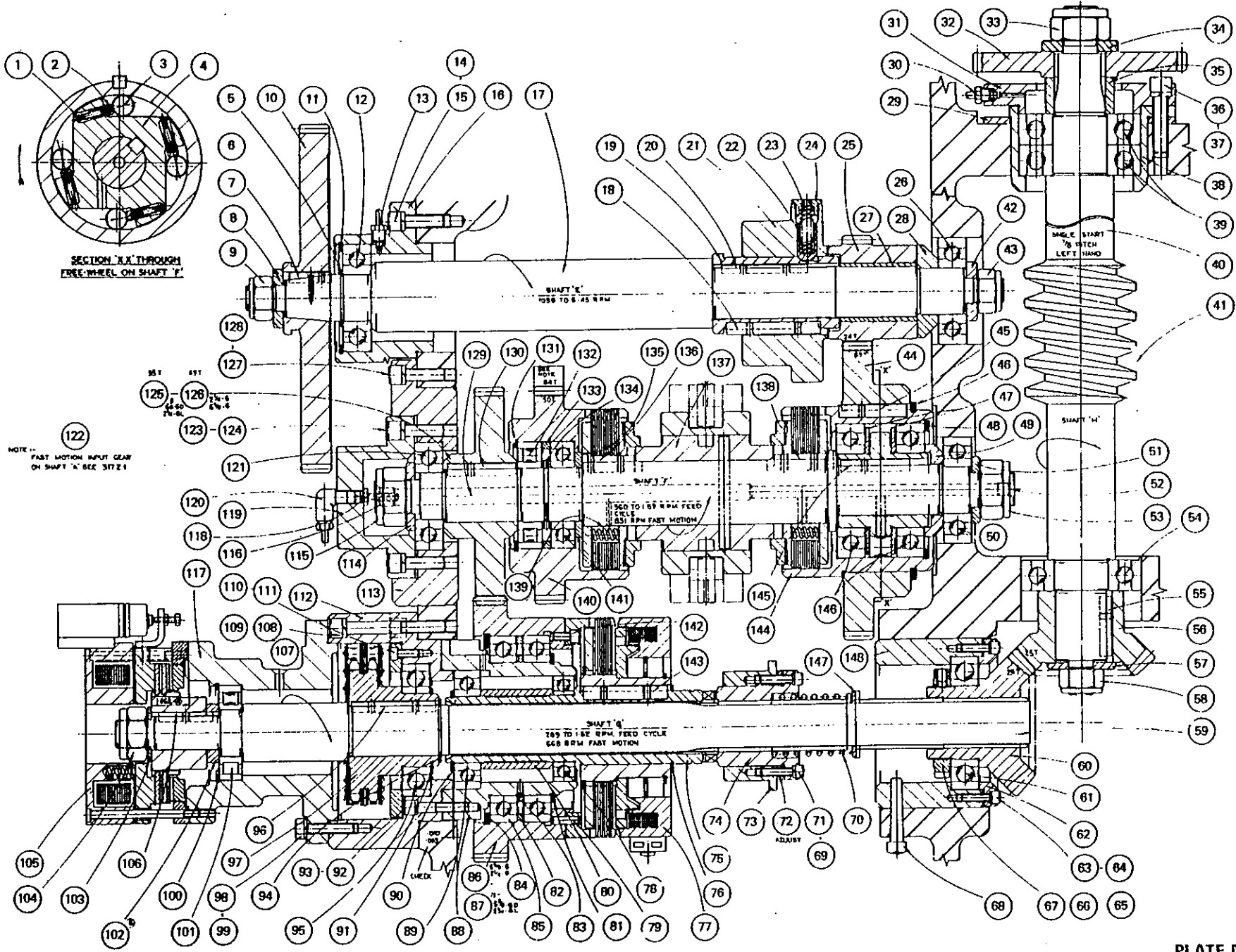

318 Z 3 ARRANGEMENT OF ELECTRO-MAGNETIC CLUTCH AND FEED BRAKE FOR FEED DRIVE

6 3/4" - 6 MACHINE. SECTION 318

COMMENCING ON
INSP. No. 15753 2 1/4 - 6
INSP. No. 15361 6 1/2 - 6

INDEX NO.	PART NO.	TITLE	INDEX NO.	PART NO.	TITLE
1	317X.128	Clamp Washer	24	318Y.125	Upper Wormwheel
2	203/16L	Selflocking Nut, Thin, 1" B.S.F.	25	318X.111	Washer
3	154/06	Spring Washer, for 3/8" dia.	26	203/16L	Selflocking Nut, Thin, 1" B.S.F.
4	155/0644	Socket Head Cap Screw, 3/8" B.S.F. x 2 1/2" long	27	237/35	Medium Metric Journal, 35-80-21mm
5	318X.207	Jockey Sprocket Assembly	28	-	Feed Motion Input Gear on Shaft "C", see 317 Z 1
6	318X.163	Jockey Eccentric	29	203/12L	Selflocking Nut, Thin, 3/4" B.S.F.
7	155/0620	Socket Head Cap Screw, 3/8" B.S.F. x 1 1/2" long	30	518X.197	Collar
8	154/06	Spring Washer, for 3/8" dia.	31	318X.178	Gear, 67 teeth (6 3/4" - 6D, 2 1/2" - 6L)
9	215/3	Tubing Nut, for 3/16" o.d. dia. Tube (Section 368)	32	318X.183	Gear, 81 teeth (2 1/4" - 6, 6 3/4" - 6, 2 3/4" - 4, 8" - 4)
10	518X.201	Key	33	518X.201	Key
11	159/408	Countersunk Screw, 4 B.A. x 1/2" long	34	159/408	Countersunk Screw, 4 B.A. x 1/2" long
12	203/12L	Selflocking Nut, Thin, 3/4" B.S.F.	35	203/12L	Selflocking Nut, Thin, 3/4" B.S.F.
13	518X.148	Washer	36	518X.148	Washer
14	-	See Table	37	318X.145	Input Shaft
15	103/21	External Circlip, 35mm	38	103/21	External Circlip, 35mm
16	104/36	Internal Circlip, 72mm	39	258/35	Light Metric Journal, 35-72-17mm
17	318X.167	Clutch Member	40	-	Shaft "E", see 318 Z 2
18	318X.168	Wormshaft Sprocket	41	318X.101	Bearing Housing
19	318X.114	Bearing Cap	42	258/35	Light Metric Journal, 35-72-17mm
20	215/3	Tubing Nut, for 3/16" o.d. dia. Tube	43		List of available feed gears 8 DP 20 P.A.
21	318X.117A	Bearing Housing			
22	S022	Medium Angular Contact Bearing 40 x 90 x 23mm			
23	318Y.138	Upper Wormshaft			

No. of teeth	Drawing Ref. No.	No. of teeth	Drawing Ref. No.	No. of teeth	Drawing Ref. No.	No. of teeth	Drawing Ref. No.
-----------------	---------------------	-----------------	---------------------	-----------------	---------------------	-----------------	---------------------

List of Parts for
Plate No. 19B
(Drawing No. 318 Z 3)

WHEN ORDERING SPARE PARTS ALWAYS QUOTE THE INSPECTION NUMBER OF THE MACHINE

2 1/4"-6, 2 1/4"-6D BAR MACHINES. 6 1/4"-6, 6 1/4"-6D CHUCKING MACHINES

43

LIST OF AVAILABLE FEED GEARS 5 OR 20° PA							
ONE REF. #	ONE REF. #	ONE REF. #	ONE REF. #	ONE REF. #	ONE REF. #	ONE REF. #	ONE REF. #
51T	518 X 171	51T	518 X 171	55T	518 X 182	70T	518 X 179
61T	518 X 178	56T	518 X 176	55T	518 X 173	72T	518 X 180
64T	518 X 172	42T	518 X 179	57T	518 X 174	75T	518 X 181
77T	518 X 173	44T	518 X 180	60T	518 X 175	81T	518 X 182
79T	518 X 174	47T	518 X 181	62T	518 X 176	81T	518 X 183
82T	518 X 175	49T	518 X 184	65T	518 X 177		
84T	518 X 176	50T	518 X 172	67T	518 X 178		

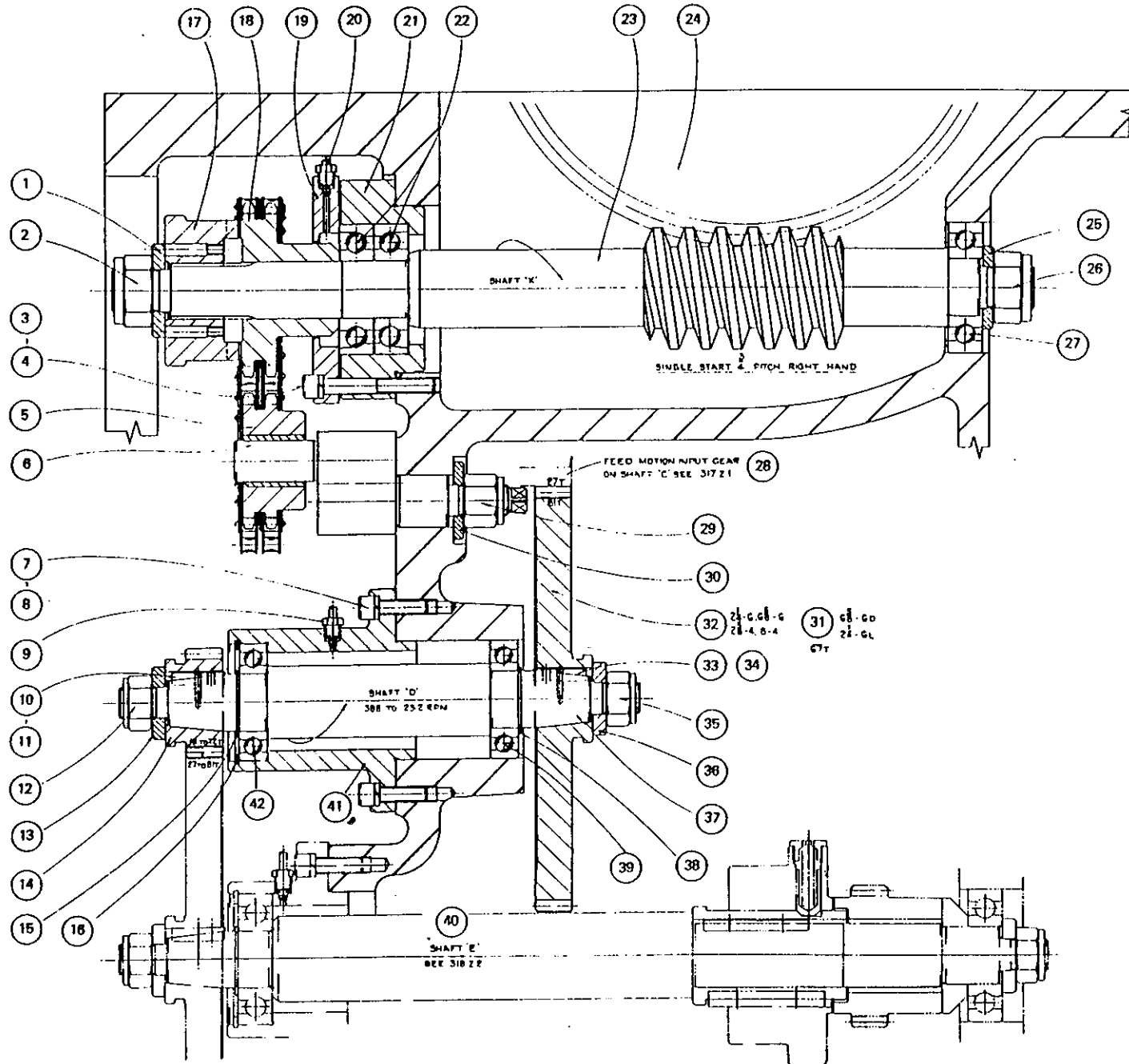

PLATE No.19B
(Drawing No.31823)

318 Z 4A MOTOR DRIVE END OF MAIN DRIVE HOUSING (ELECTRO-MAGNETIC BRAKE AND CLUTCH)

2 1/4"-6, 6 3/8"-6 MACHINES. SECTION 318

COMMENCING ON
INSP. No.15753 2 1/4"-6
INSP. No.15361 6 3/8"-6

INDEX NO.	PART NO.	TITLE
1	—	Spindle Speed Pick-Off Gears, 28-68 teeth 8 D.P. 20° P.A.
2	—	Spindle Speed Pick-Off Gears 40-80 teeth 8 D.P. 20° P.A.
3	—	Feed Pick-Off Gears 19-72 teeth 8 D.P. 20° P.A.
4	—	Upper Wormshaft Sprocket, 25 teeth, 1/2 pitch
5	—	Renold Chain 114046 1/2 pitch 0.335 Roller dia. Duplex 100 pitches long
6	154/05	Spring Washer, for 5/16" dia.
7	155/0516	Socket Head Cap Screw, 5/16" B.S.F. x 1" long
8	—	See Arrangement Drawing 322 Z 3B
9	—	Feed Pick-Off Gears 27-81 teeth 8 D.P. 20° P.A.
10	291/81	Legend Plate
11	165/404	Round Head Screw, 4 B.A. x 1/4" long
12	291/2	Legend Plate
13	118X.141	Spring Retaining Plug
14	165/404	Round Head Screw, 4 B.A. x 1/4" long
15	318X.253	Brake Release Instruction Plate
16	118V.255	Brake Adjustment Name Plate
17	165/404	Round Head Screw, 4 B.A. x 1/4" long
18	322X.242	Reset Pin Retaining Plate
19	322V.241	Brake Housing Cover
20	155/0410	Socket Head Cap Screw, 1/4" B.S.F. x 3/8" long
21	154/04	Spring Washer, for 1/4" dia.
22	322Z.240	Magnetic Brake Housing
23	322X.244	Coolant Drive End Cover
24	155/0410	Socket Head Cap Screw, 1/4" B.S.F. x 3/8" long
25	154/04	Spring Washer, for 1/4" dia.
26	—	Renold Chain 110046 ; pitch 0.335 dia. roller 94 pitches, 2 1/4"-6 89 pitches, 6 3/8"-6
27	—	See 369 Z5 for Coolant Drive
28	—	Renold Chain 110038 3/8 pitch 0.25 dia. roller 72 pitches long

List of Parts for
Plate No. 19C
(Drawing No. 318 Z4A)

WHEN ORDERING SPARE PARTS ALWAYS QUOTE THE INSPECTION NUMBER OF THE MACHINE

ELECTRO-MAGNETIC FEED CLUTCH & BRAKE

2 1/4"-6, 2 1/4"-6D BAR MACHINES. 6 1/4"-6, 6 1/4"-6D CHUCKING MACHINES

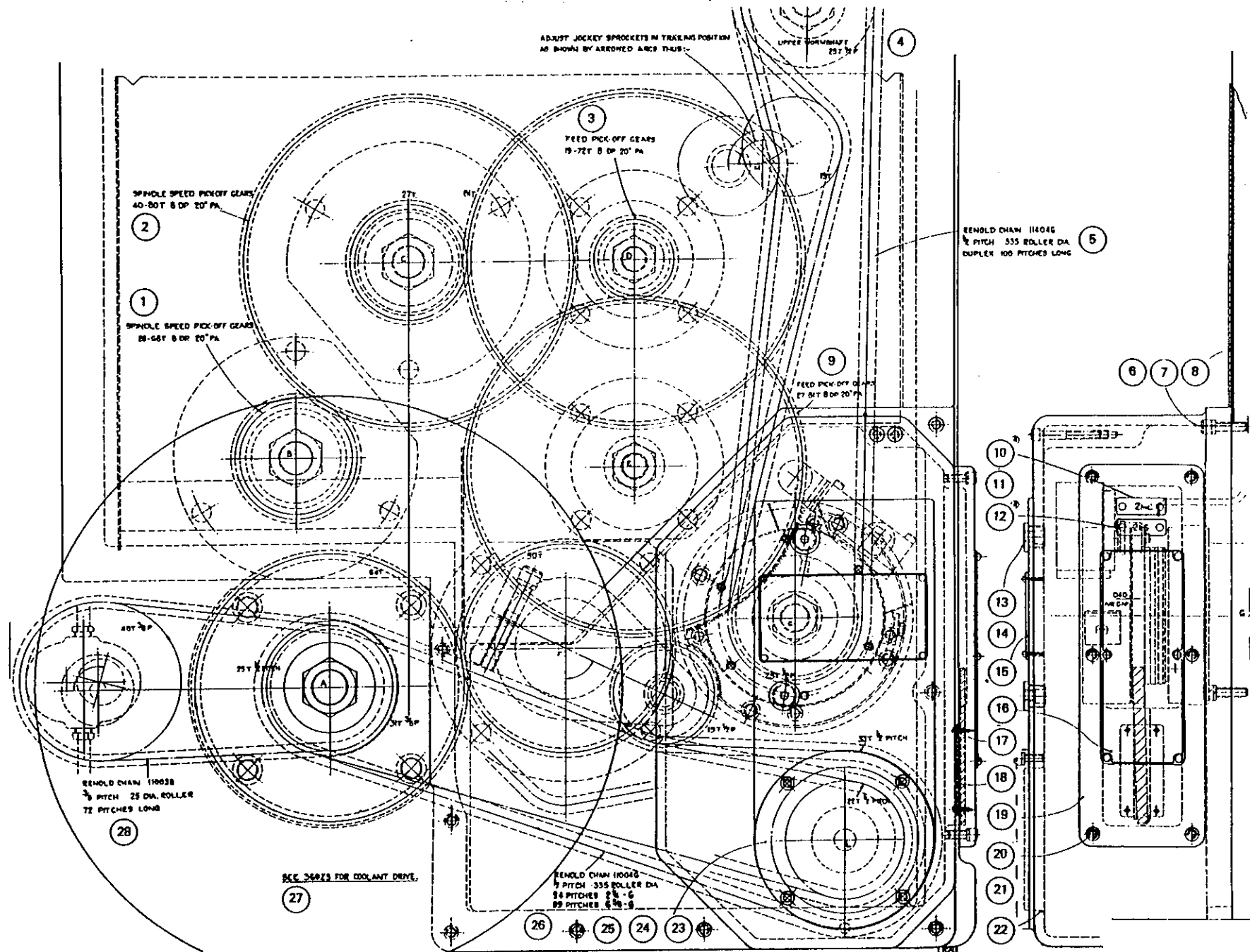

PLATE No.19C
(Drawing No.31824A)

**WICKMAN
MULTI-SPINDLE
AUTOMATICS**

MACHINE CONTROLS
2 $\frac{1}{4}$ "-6, 2 $\frac{1}{4}$ "-6D, 2"-6 AND 2"-6D BAR MACHINES
6 $\frac{5}{8}$ "-6, 6 $\frac{5}{8}$ "-6D CHUCKING MACHINES

Last Used On
M/c No.14704 - 6 $\frac{1}{4}$ "-6
M/c No.15752 - 2 $\frac{1}{4}$ "-6

INDEX NO.	PART NO.	TITLE.	INDEX NO.	PART NO.	TITLE.
1	319X.131	Feed Motion Cam.	45	155/0624	$\frac{1}{2}$ " B.S.F. Socket Head Cap Screw, 1 $\frac{1}{2}$ " long.
2	319X.130	Fast Motion Cam	46	154/06	$\frac{1}{2}$ " Spring Washer.
3	183/0520	$\frac{1}{8}$ " B.S.F. Taper Point Screw, 1 $\frac{1}{2}$ " long.	47	121/1032T	$\frac{1}{8}$ " Square Tapped Key, 2" long.
4	203/05	$\frac{1}{8}$ " B.S.F. Self-Locking Nut.	48	319V.126	Glut Lever.
5	188/0624	$\frac{1}{2}$ " B.S.F. Square Head Set Screw, 1 $\frac{1}{2}$ " long.	49	319X.192	Glut Pin
6	203/06L	$\frac{1}{2}$ " B.S.F. Self-Locking Nut (Thin).	50	319X.110	Glut.
7	319X.139	Link End.	51	198/8	$\frac{1}{2}$ " dia. Shakeproof Internal Serrated Washer.
8	119X.197	Special Locknut.	52	155/0408	$\frac{1}{2}$ " B.S.F. Socket Head Cap Screw, $\frac{1}{2}$ " long.
9	155/0524	$\frac{1}{8}$ " B.S.F. Socket Head Cap Screw, 1 $\frac{1}{2}$ " long.	53	CRLN2-LH5FT	Burgess "Micro" Switch, 5 ft. leads.
10	203/05L	$\frac{1}{8}$ " B.S.F. Self-Locking Nut (Thin).	54	130/04	$\frac{1}{2}$ " dia. Flat Washer.
11	154/05	$\frac{1}{8}$ " Spring Washer.	55	319X.125	Lever.
12	319X.129B	Switch Bracket.	56	101/2	$\frac{1}{2}$ " dia. External Circlip.
13	119X.142A	Link.	57	519X.144	Link Pin.
14	155/0514	$\frac{1}{8}$ " B.S.F. Socket Head Cap Screw, $\frac{1}{2}$ " long	58	198/8	$\frac{1}{2}$ " dia. Shakeproof Internal Serrated Washer.
15	154/05	$\frac{1}{8}$ " Spring Washer.	59	155/0408	$\frac{1}{2}$ " B.S.F. Socket Head Cap Screw, $\frac{1}{2}$ " long.
16	203/08	$\frac{1}{8}$ " B.S.F. Self-Locking Nut.	60	319X.128	Switch Plate.
17	319X.143	Link End.	61	130/10	$\frac{1}{2}$ " dia. Flat Washer.
18	519X.194	Roller.	62	203/10L	$\frac{1}{2}$ " B.S.F. Self-Locking Nut (Thin).
19	519X.133A	Operating Lever Roller Pin.	63	155/0614	$\frac{1}{2}$ " B.S.F. Socket Head Cap Screw, $\frac{1}{2}$ " long.
20	319V.119	Lever.	64	154/06	$\frac{1}{2}$ " Spring Washer.
21	154/05	$\frac{1}{8}$ " Spring Washer.	65	319X.176	"T" Nut.
22	155/0514	$\frac{1}{8}$ " B.S.F. Socket Head Cap Screw, $\frac{1}{2}$ " long.	66	—	$\frac{1}{2}$ " dia. Steel Ball.
23	319X.175	Lever Pivot Pin.	67	219X.193	Locating Spring.
24	101/2	$\frac{1}{2}$ " dia. External Circlip.	68	219X.194	Spring Retainer.
25	519X.144	Link Pin.	69	597BX.124	Fork Pin.
26	182/0620	$\frac{1}{2}$ " B.S.F. Socket Set Screw, Taper Point, 1 $\frac{1}{2}$ " long.	70	130/05	$\frac{1}{2}$ " dia. Flat Washer.
27	153X.111	Plunger.	71	127/0605	$\frac{1}{2}$ " dia. Split Cotter Pin, $\frac{1}{2}$ " long.
28	153X.118A	Plunger Spring	72	B.S.4	"Oillite" Bearing.
29	519X.184A	Fast Motion Lever Boss.	73	519X.167	Hand Wind Drive Dog.
30	241/13	1 $\frac{1}{2}$ " dia. Bakelite Knob (Red).	74	125/2232	$\frac{1}{2}$ " dia. Taper Pin, 2" long.
31	519X.160A	Fast Motion Lever.	75	319X.189	Hand Wind Sliding Gear.
32	519X.186	Pivot Pin.	76	316X.149	Hand Wind Shaft.
33	179/204	2 B.A. Socket Set Screw, $\frac{1}{2}$ " long.	77	101/18	$\frac{1}{2}$ " dia. External Circlip.
34	164/0408	$\frac{1}{2}$ " B.S.F. Round Head Screw, $\frac{1}{2}$ " long.	78	319V.118	Detent Lever.
35	519X.185	Cover Plate.	79	125/1620	$\frac{1}{2}$ " dia. Taper Pin, 1 $\frac{1}{2}$ " long.
36	101/13	1 $\frac{1}{2}$ " External Circlip.	80	319X.134	Detent.
37	319X.186	Spacer.	81	319X.113A	Bearing Sleeve.
38	154/05	$\frac{1}{8}$ " Spring Washer.	82	155/0514	$\frac{1}{8}$ " B.S.F. Socket Head Cap Screw, $\frac{1}{2}$ " long.
39	155/0506	$\frac{1}{8}$ " B.S.F. Socket Head Cap Screw, $\frac{1}{2}$ " long.	83	125/2232	$\frac{1}{2}$ " dia. Taper Pin, 2" long.
40	319X.103	Bearing Bush.	84	154/04	$\frac{1}{8}$ " Spring Washer.
41	155/0624	$\frac{1}{2}$ " B.S.F. Socket Head Cap Screw, 1 $\frac{1}{2}$ " long.	85	519X.167	Hand Wind Drive Dog.
42	154/06	$\frac{1}{8}$ " Spring Washer.	86	FY.52198	Lever.
43	121/1032T	$\frac{1}{8}$ " Square Tapped Key, 2" long.	87	519X.204	Revolving Handle.
44	319X.161	Fast Motion Lever Shaft.			

List of Parts for
PLATE No. 20
(Drawing No. 319 Z 1)

WHEN ORDERING SPARE PARTS ALWAYS QUOTE THE SERIAL NUMBER OF THE MACHINE

MACHINE CONTROLS

2¼"-6, 2¼"-6D, 2"-6 AND 2"-6D BAR MACHINES
6⅝"-6, 6⅝"-6D CHUCKING MACHINES

Last Used On
Machine No.14704 - 6¼"-6
Machine No.15762 - 2¼"-6

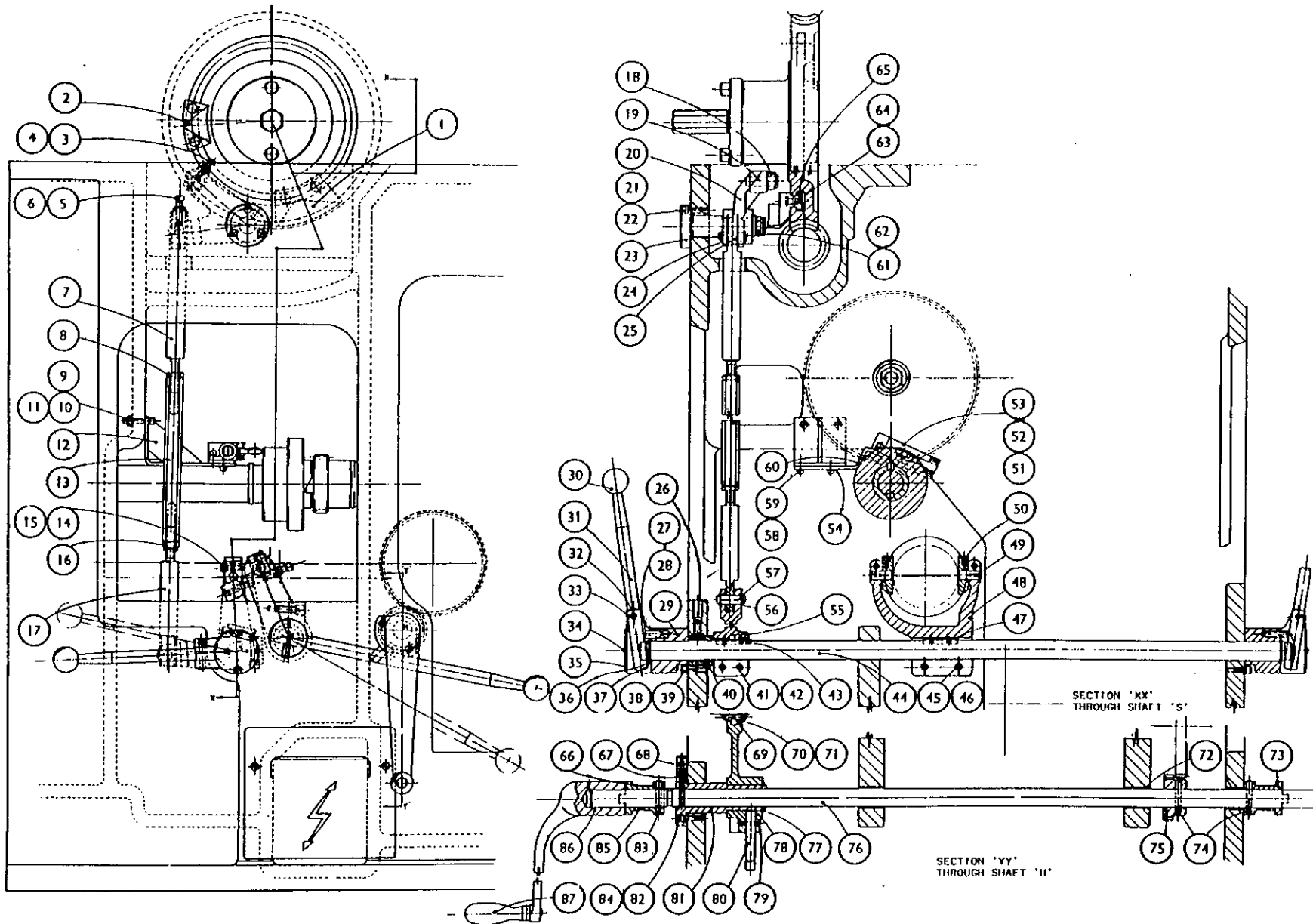

319 Z 5 CONTROL SHAFT ARRANGEMENT

6 $\frac{1}{2}$ "-6, 2 $\frac{1}{4}$ "-6 MACHINES. SECTION 319

INDEX NO.	PART NO.	TITLE	INDEX NO.	PART NO.	TITLE
1	182/0416	Set Screw, Taper Point, $\frac{1}{4}$ " B.S.F. x 1" long	41	241/9	Bakelite Knob
2	241/9	Bakelite knob	42	319X.218	Link Screw, Right Hand
3	319X.227	Feed Lever	43	173/08L	Hexagon Locknut, $\frac{3}{8}$ " B.S.F.
4	125/2236	Taper Pin, 11/32" x 2 $\frac{1}{2}$ " long	44	319X.219	Adjusting Nut
5	182/0612	Set Screw, Taper Point, $\frac{3}{8}$ " B.S.F. x $\frac{3}{4}$ " long	45	419X.135	Special Locknut
6	182/0620	Set Screw, Taper Point, $\frac{3}{8}$ " B.S.F. x 1 $\frac{1}{2}$ " long	46	319X.217	Link Screw, Left Hand
7	319V.203	Lever	47	155/0824	Socket Head Cap Screw, $\frac{3}{8}$ " B.S.F. x 1 $\frac{1}{2}$ " long
8	121/1020T	Key, Tapped, 6/16" x 1 $\frac{1}{4}$ " long	48	154/06	Spring Washer, for $\frac{3}{8}$ " dia.
9	130/06	Flat Washer, for $\frac{3}{4}$ " dia.	49	125/2232	Taper Pin, 11/32" x 2" long
10	219X.192	Glut Pin	50	319X.211	Handwind Sliding Gear
11	219X.110	Glut	51	BS4	Oilite Bearing, 1/16" bore
12	327/0608	Cotter Pin, 3/32" dia. x 1" long	52	319X.224	Trip Collar
13	319X.214	Link Pin	53	325/0828	Tension Pin, $\frac{1}{2}$ " dia. x 1 $\frac{1}{2}$ " long
14	101/20	External Circlip, 1 $\frac{1}{2}$ " dia.	54	-	Soft Iron Wire, 18 S.W.G.
15	219X.110	Glut	55	154/04	Spring Washer, for $\frac{1}{2}$ " dia.
16	219X.192	Glut Pin	56	155/0412	Socket Head Cap Screw, $\frac{1}{4}$ " B.S.F. x $\frac{3}{4}$ " long
17	319Y.201	Glut Lever	57	BS1A1	Switch, Square D, Class 9007, Type B
18	121/1032T	Key, Tapped, 5/16" square x 2" long	58	MA 1	Lever Arm, Square D, Class 9007
19	101/20	External Circlip, 1 $\frac{1}{2}$ " dia.	59	101/18	External Circlip, 1 $\frac{1}{2}$ " dia.
20	319Y.205	Glut Sleeve	60	319X.213	Spacer
21	319V.206	Feed Lever Shaft	61	319V.204	Lever
22	101/20	External Circlip, 1 $\frac{1}{2}$ " dia.	62	319X.215	Link Pin
23	121/1024T	Key, Tapped, 5/16" square x 1 $\frac{1}{2}$ " long	63	319X.216	Link
24	319Y.202	Interlock Lever	64	154/05	Spring Washer, for 5/16" dia.
25	101/20	External Circlip, 1 $\frac{1}{2}$ " dia.	65	155/0514	Socket Head Cap Screw, 5/16" B.S.F. x $\frac{3}{4}$ " long
26	319V.207	Bearing Sleeve	66	319V.208	Bearing Sleeve
27	155/0514	Socket Head Cap Screw, 5/16" B.S.F. x $\frac{7}{8}$ " long	67	319X.230	Handwind Shaft
28	154/05	Spring Washer, for 5/16" dia.	68	-	Steel Ball, 5/16" dia.
29	319V.210	Front Lever Boss	69	519X.204	Revolving Handle
30	319X.226	Spacer	70	FY 5219B	Lever
31	155/0506	Socket Head Cap Screw, 5/16" B.S.F. x $\frac{3}{4}$ " long	71	519X.167	Handwind Drive Dog
32	182/0612	Set Screw, Taper Point, $\frac{3}{8}$ " B.S.F. x $\frac{1}{2}$ " long	72	125/2232	Taper Pin, 11/32" dia. x 2" long
33	125/2236	Taper Pin, 11/32" dia. x 2 $\frac{1}{2}$ " long	73	219X.193	Locating Spring
34	182/0416	Set Screw, Taper Point, $\frac{1}{2}$ " B.S.F. x 1" long	74	219X.194	Spring Retainer
35	BS4	Oilite Bearing, 1.1/16" bore	75	327/0608	Cotter Pin, 3/32" dia. x 1" long
36	125/2232	Taper Pin, 11/32" dia. x 2" long	76	319X.214	Link Pin
37	319X.148	Collar	77	130/06	Flat Washer, for $\frac{3}{8}$ " dia.
38	125/2232	Taper Pin, 11/32" dia. x 2" long	78	319X.103	Bearing Bush
39	519X.167	Handwind Drive Dog	79	319V.209	Rear Lever Boss
40	319X.227	Feed Lever			

List of Parts for
Plate No. 20A
(Drawing No. 319 Z5)

WHEN ORDERING SPARE PARTS ALWAYS QUOTE THE INSPECTION NUMBER OF THE MACHINE

CONTROL SHAFT ARRANGEMENT

2 1/4"-6, 2 1/4"-6D, 2"-6 AND 2"-6D BAR MACHINES. 6 1/2"-6, 6 1/2"-6D CHUCKING MACHINES

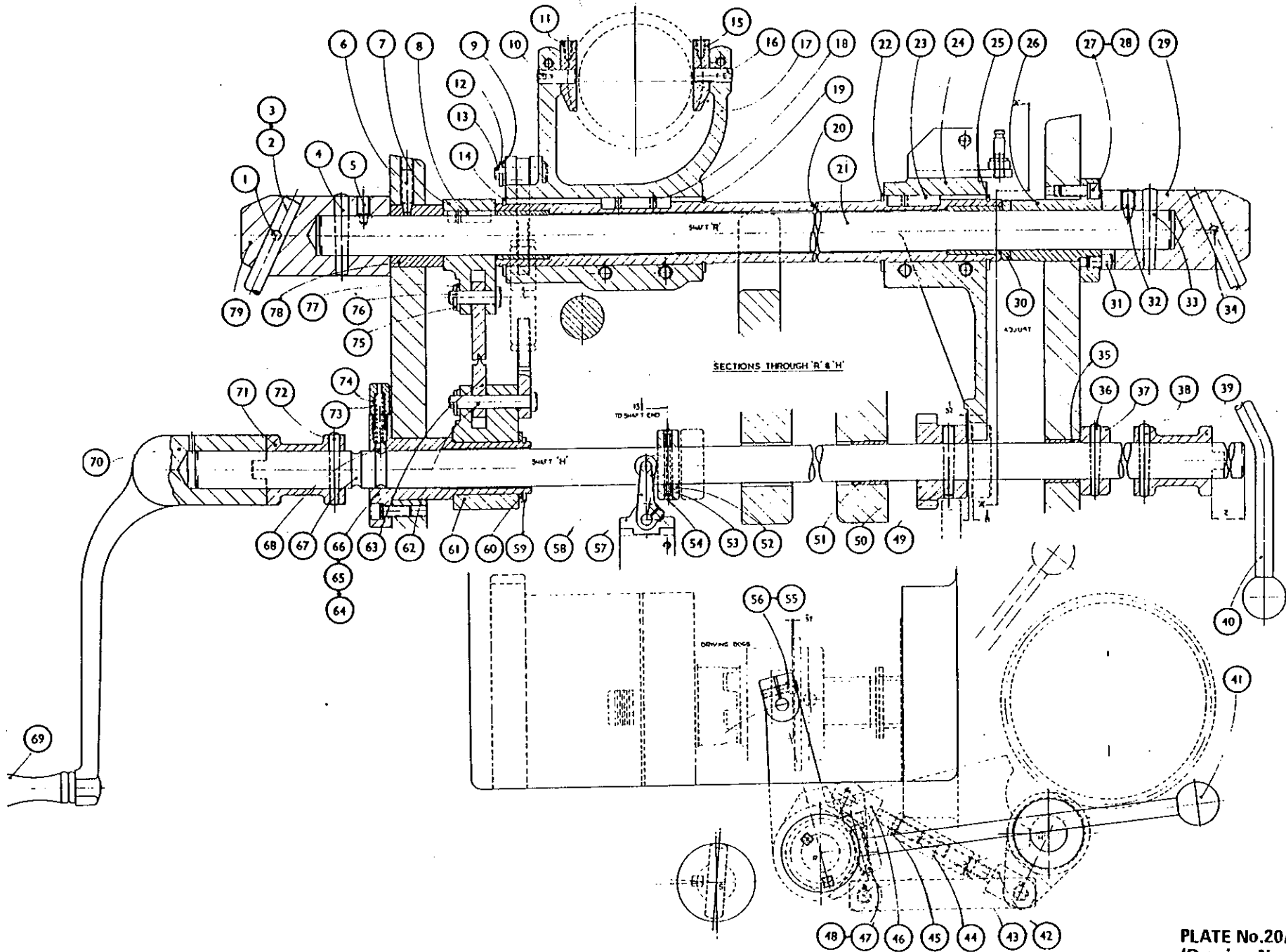

**WICKMAN
MULTI-SPINDLE
AUTOMATICS**

MACHINE CONTROLS

2¼"-6, 2¼"-6D, 2"-6 AND 2"-6D BAR MACHINES

6⅜"-6, 6⅜"-6D CHUCKING MACHINES

Last Used On
M/c No.14704 - 6¼"-6
M/c No.15752 - 2¼"-6

INDEX NO.	PART NO.	TITLE.	INDEX NO.	PART NO.	TITLE.
1	319X.192	Glut Pin.	33	203/06	¾" B.S.F. Self-Locking Nut.
2	319X.110	Glut.	34	319X.123	Spring Anchor.
3	319X.191	Glut Pin.	35	MSE.325	Morris Extension Spring.
4	319X.116	Lever.	36	197/11	⅜" dia. External Serrated Washer.
5	121/1024T	⅜" Square Tapped Key, 1¼" long.	37	167/0516H	⅜" B.S.F. Hexagon Head Screw, 1" long.
6	182/0620	¾" B.S.F. Socket Set Screw, Taper Point, 1¼" long.	38	155/0514	⅜" B.S.F. Socket Head Cap Screw, ¾" long.
7	121/1024T	⅜" Square Tapped Key, 1¼" long.	39	154/05	⅜" Spring Washer.
8	182/0616	¾" B.S.F. Socket Set Screw, Taper Point, 1" long.	40	188/0644	¾" B.S.F. Square Head Set Screw, 2½" long.
9	519X.146	Feed Lever.	41	203/06L	¾" B.S.F. Self-Locking Nut (Thin).
10	319X.179	Lever Boss.	42	155/0620	¾" B.S.F. Socket Head Cap Screw, 1¼" long.
11	182/0612	¾" B.S.F. Socket Set Screw, Taper Point, ¾" long.	43	154/06	¾" Spring Washer.
12	319X.103	Bearing Bush.	44	354/0512	Oil Sealing "O" Ring for ½" bore
13	155/0512	⅜" B.S.F. Socket Head Cap Screw, ¾" long.	45	194/8	½" B.S.P. Socket Pipe Plug.
14	154/05	⅜" Spring Washer.	46	241/13	1¼" dia. Black Bakelite Knob.
15	143/1636	½" dia. Mills Grooved Pin, 2½" long.	47	319X.135	Latch Plate.
16	319V.117	Brake Operating Lever.	48	182/0510	⅜" B.S.F. Socket Set Screw, Taper Point, ¾" long.
17	236/182220	Oil Retaining Bush.	49	120X.110A	Pull Rod Sleeve.
18	319V.121	Glut Lever.	50	120X.119	Solenoid Return Spring.
19	182/0620	¾" B.S.F. Socket Set Screw, Taper Point, 1¼" long.	51	120X.111	Screwed Sleeve.
20	203/06	¾" B.S.F. Self-Locking Nut.	52	173/10L	¾" B.S.F. Hexagon Locknut.
21	121/1032T	⅜" Square Tapped Key, 2" long.	53	319X.136A	Pull Rod.
22	319V.105	Glut Sleeve.	54	173/04	½" B.S.F. Hexagon Nut.
23	319X.147	Feed Lever Shaft.	55	154/04	½" Spring Washer.
24	319V.181A	Interlock Lever.	56	167/0408	½" B.S.F. Hexagon Head Screw, ½" long.
25	182/0828	½" B.S.F. Socket Set Screw, Taper Point, 1¾" long.	57	FV.5416B/1	Solenoid, "Varley", 110 volt.
26	203/08	½" B.S.F. Self-Locking Nut.	58	120X.102C	Solenoid Platform.
27	236/182220	Oil Retaining Bush.	59	155/0512	⅜" B.S.F. Socket Head Cap Screw, ¾" long.
28	182/0620	¾" B.S.F. Socket Set Screw, Taper Point, 1¼" long.	60	130/05	⅜" Flat Washer.
29	203/06	¾" B.S.F. Self-Locking Nut.	61	319X.146	Brake Operating Spring.
30	319X.104	Collar.	62	597BX.124	Fork Pin.
31	319X.123	Spring Anchor.	63	127/0605	⅜" dia. Split Cotter Pin, ¾" long.
32	173/06L	¾" B.S.F. Locknut.	64	319X.108A	Anchor Sleeve.
			65	155/10120	½" B.S.F. Socket Head Cap Screw, 7¼" long.

List of Parts for
PLATE No. 21
(Drawing No. 319 Z 2)

WHEN ORDERING SPARE PARTS ALWAYS QUOTE THE SERIAL NUMBER OF THE MACHINE

MACHINE CONTROLS

2¼"-6, 2¼"-6D, 2"-6 AND 2"-6D BAR MACHINES

6⅝"-6, 6⅝"-6D CHUCKING MACHINES

Last Used On

Machine No. 14704 - 6¼"-6

Machine No. 15752 - 2¼"-6

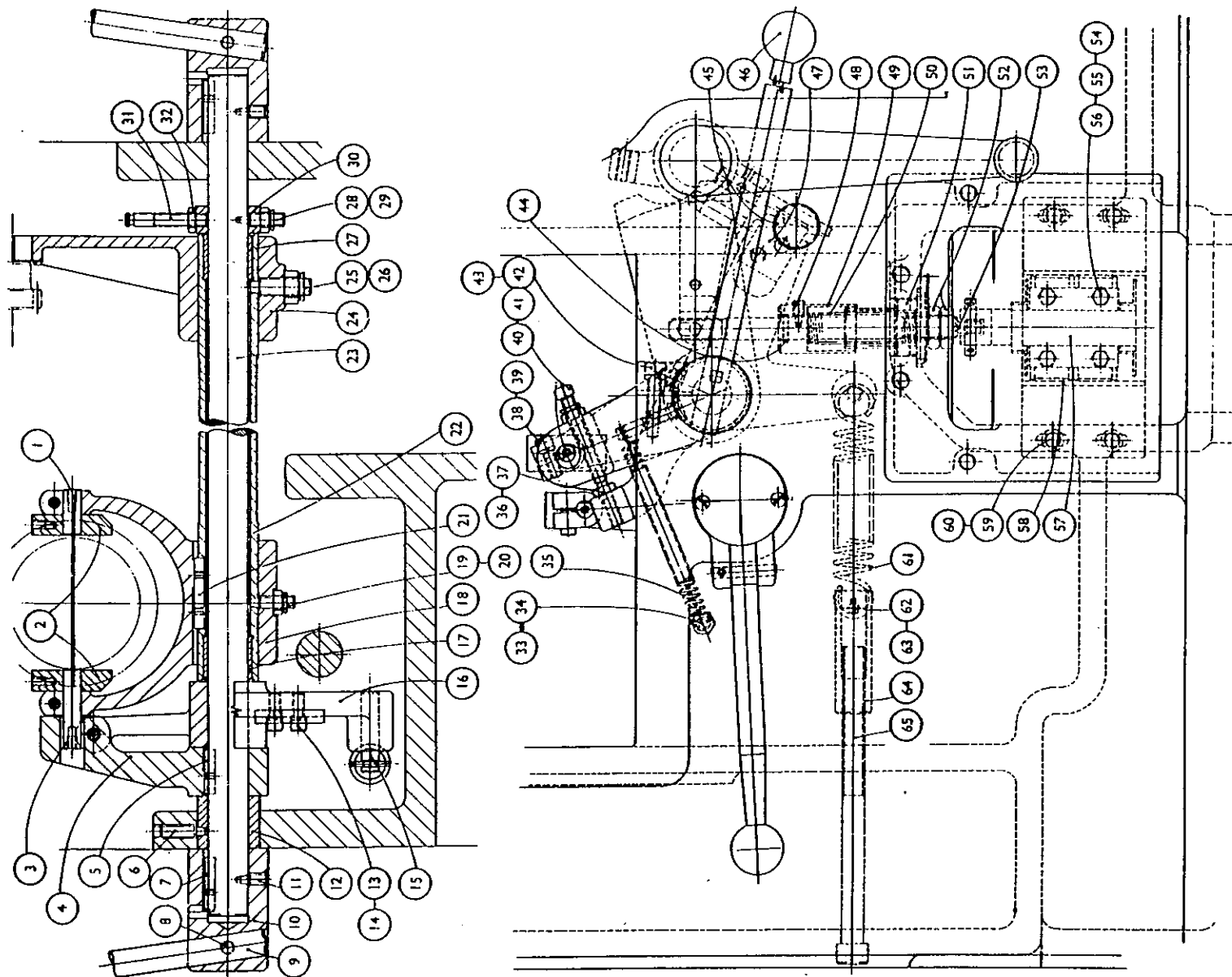

319 Z 6 CONTROL SHAFT ARRANGEMENT
6 $\frac{1}{8}$ "-6, 2 $\frac{1}{4}$ "-6 MACHINES. SECTIONS 319, 319A

Last Used On
 Machine No.16347
 (Excepting Machine No.16352)

INDEX NO.	PART NO.	TITLE	INDEX NO.	PART NO.	TITLE
1	155/0412	Socket Head Cap Screw, 1/4" B.S.F. x 1/4" long	37	167/0412	Hexagon Head Screw, 1/4" B.S.F. x 3/4" long
2	203/04	Selflocking Nut, 1/4" B.S.F.	38	198/8	Shakeproof Washer, for 1/4" B.S.F.
3	130/04	Flat Washer, for 1/4" dia.	39	AW 12	Limit Switch, Square D, Class 9007
4	319X.130	Fast Motion Cam	40	2441-D87-X1	Conduit Seal
5	203/05	Selflocking Nut, 5/16" B.S.F.	41	BA 1	Operating Arm, Square D
6	183/0520	Square Head Screw, Taper Point, 5/16" B.S.F. x 1 1/4" long	42	167/0524	Hexagon Head Screw, 5/16" B.S.F. x 1 1/2" long
7	319X.131	Feed Motion Cam	43	203/06	Selflocking Nut, 3/8" B.S.F.
8	203/06L	Selflocking Nut, Thin, 3/8" B.S.F.	44	319X.123	Spring Anchor
9	188/0624	Square Head Set Screw, 3/8" B.S.F. x 1 1/2" long	45	USE 325	Morris Spring
10	319X.139	Link End	46	167/0412	Hexagon Head Screw, 1/4" B.S.F. x 1/4" long
11	119X.197	Special Locknut	47	198/8	Shakeproof Washer, for 1/4" B.S.F.
12	119X.142A	Link	48	203/06	Selflocking Nut, 5/16" B.S.F.
13	165/0524	Socket Head Cap Screw, 5/16" B.S.F. x 1 1/2" long	49	319X.225	Spring Anchor
14	154/05	Spring Washer, for 5/16" dia.	50	319V.222	Trip Bracket
15	203/05L	Selflocking Nut, Thin, 5/16" B.S.F.	51	203/05	Selflocking Nut, 5/16" B.S.F.
16	519X.194	Roller	52	-	Scrap View showing bung in position in housing
17	519X.133A	Operating Lever Roller Pin	53	319X.520	Plug
18	319V.119	Lever	54	198/8	Shakeproof Washer, for 1/4" B.S.F.
19	154/05	Spring Washer, for 5/16" dia.	55	155/0408	Socket Head Cap Screw, 1/4" B.S.F. x 1/4" long
20	155/0514	Socket Head Cap Screw, 5/16" B.S.F. x 3/4" long	56	BZLN-2-LHBEG	Micro-Switch, Honeywell
21	319X.175	Lever Pivot Pin	57	319X.110	Glut
22	101/2	External Circlip, 1/2" dia.	58	319X.192	Glut Pin
23	619X.144	Link Pin	59	153X.111	Plunger
24	318X.249	Switch Bracket	60	153X.118A	Plunger Spring
25	130/04	Flat Washer, for 1/4" dia.	61	519X.184A	Fast Motion Lever Boss
26	203/04	Selflocking Nut, 1/4" B.S.F.	62	101/13	External Circlip, 1 1/4" DIA.
27	158/0412	Countersunk Socket Head Screw, 1/4" B.S.F. x 3/4" long	63	155/0506	Socket Head Cap Screw, 5/16" B.S.F. x 3/4" long
28	318X.254	Restaining Arm	64	319X.161	Fast Motion Lever Shaft
29	319X.176	Tee Nut	65	319V.126	Glut Lever
30	154/06	Spring Washer, for 3/8" dia.	66	-	Section "XX" through shaft "S"
31	155/0614	Socket Head Cap Screw, 3/8" B.S.F. x 3/4" long	67	121/1032T	Key, Tapped, 5/16" square x 2" long
32	203/10L	Selflocking Nut, Thin, 3/8" B.S.F.	68	154/06	Spring Washer, for 3/8" dia.
33	130/10	Flat Washer, for 3/8" dia.	69	155/0624	Socket Head Cap Screw, 3/8" B.S.F. x 1 1/4" long
34	156/224	Socket Cap Screw, 2 B.A. x 1 1/2" long	70	121/103T	Key, Tapped, 5/16" square x 2" long
35	154/03	Spring Washer, for 3/16" dia.	71	319X.103	Bearing Bush
36	219X.174	Switch Bracket	72	182/0620	Set Screw, Taper Point, 3/8" B.S.F. x 1 1/4" long

List of Parts for
 Plate No. 21A
 (Drawing No. 319 Z6)

WHEN ORDERING SPARE PARTS ALWAYS QUOTE THE INSPECTION NUMBER OF THE MACHINE

319 Z 6 CONTROL SHAFT ARRANGEMENT
6 $\frac{1}{8}$ "-6, 2 $\frac{1}{4}$ "-6 MACHINES. SECTIONS 319, 319A

INDEX NO.	PART NO.	TITLE
73	319X.186	Spacer
74	101/13	External Circlip, 1 $\frac{1}{8}$ " dia.
75	319X.128	Switch Plate
76	519X.144	Operating Lever Roller Pin
77	101/2	External Circlip, $\frac{1}{2}$ " dia.
78	319X.125	Lever
79	24 1/13	Knob, Red, 1 $\frac{1}{2}$ " dia.
80	519X.160A	Fast Motion Lever
81	179/204	Socket Set Screw, 2 B.A. x $\frac{1}{2}$ " long
82	156/228	Socket Cap Screw, 2 B.A. x 1 $\frac{1}{4}$ " long
83	154/08	Spring Washer, for $\frac{1}{2}$ " dia.
84	519X.186	Pivot Pin
85	164/0408	Round Head Set Screw, $\frac{1}{4}$ " B.S.F. x $\frac{1}{2}$ " long
86	519X.185	Cover Plate
87	319V.223	Switch Bracket
88	167/0514	Hexagon Head Screw, 5/16" B.S.F. x $\frac{7}{8}$ " long
89	198/12	Shakeproof Washer, for 5/16" dia.
90	203/08	Selflocking Nut, $\frac{1}{2}$ " B.S.F.
91	319X.143	Link End
92	155/0514	Socket Head Cap Screw, 5/16" B.S.F. x $\frac{7}{8}$ " long
93	154/05	Spring Washer, for 5/16" dia.
94	361/1820	Square Head Plug, 1 $\frac{1}{2}$ " B.S.P.

**List of Parts for
Plate No. 21A
(Drawing No. 319 Z6)**

WHEN ORDERING SPARE PARTS ALWAYS QUOTE THE INSPECTION NUMBER OF THE MACHINE

CONTROL SHAFT

2 1/4"-6, 2 1/4"-6D, 2"-6 AND 2"-6D BAR MACHINES. 6 1/8"-6, 6 1/8"-6D CHUCKING MACHINES

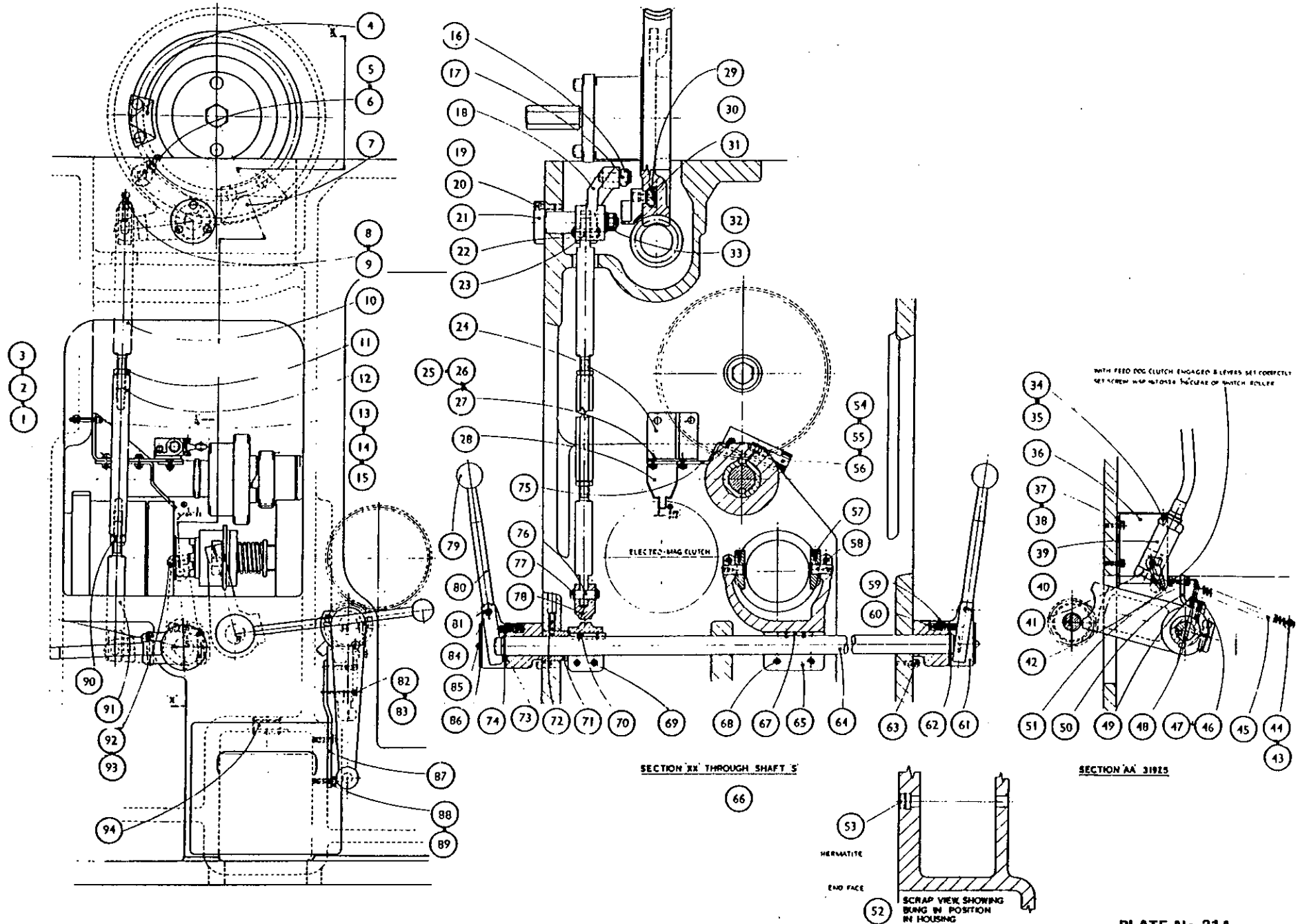

319 Z 6A CONTROL SHAFT ARRANGEMENT

2 1/4" - 6, 6 3/4" - 6 MACHINES

Commencing
Machine No.16348
(Excepting Machine 1635)

INDEX NO.	PART NO.	TITLE	INDEX NO.	PART NO.	TITLE
1	319X.130	Fast Motion Cam	45	182/0612	3/8" BSF Socket Set Screw 3/4" long Taper point
2	203/06	5/16" BSF Self Locking Nut	46	182/0620	3/8" BSF Socket Set Screw 1 1/2" long Taper point
3	183/0520	5/16" BSF Square Head Set Screw 1 1/2" long Taper point	47	319X.103	Bearing Bush
4	319X.131	Feed Motion Cam	48	121/1032T	5/16" Square Tapped Key 2" long
5	203/06L	3/8" BSF Self Locking Nut	49	155/0624	3/8" BSF Socket Head Cap Screw 1 1/2" long
6	188/0624	3/8" BSF Square Head Set Screw 1 1/2" long	50	154/06	3/8" Spring Washer
7	319X.139	Link End	51	121/1032T	5/16" Square Tapped Key 2" long
8	119X.197	Special Locknut	52	319V.126	Glut Lever
9	119X.142A	Link	53	319X.161A	Fast Motion Lever Shaft
10	155/0524	5/16" BSF Socket Head Cap Screw 1 1/2" long	54	219X.136	Spacer
11	154/05	5/16" Spring Washer	55	182/0612	3/8" BSF Socket Set Screw 3/4" long Taper point
12	203/05L	5/16" BSF Self Locking Nut	56	121/1024T	5/16" Square Tapped Key 1 1/2" long
13	156/228	2BA Socket Head Cap Screw 1 1/2" long	57	219V.135	Lever Boss
14	154/03	3/16" Spring Washer	58	319X.192	Glut Pin
15	319V.223	Switch Bracket	59	319X.110	Glut
16	167/0514	5/16" BSF Hexagon Head Set Screw 7/8" long	60	8ZLN-2-LHBE6	Honeywell Micro Switch
17	198/12	5/16" Lockwasher	61	155/0408	1/4" BSF Socket Head Cap Screw 1/2" long
18	361/1820	1 1/2" BSP Square Head Plug	62	198/8	1/4" Lock Washer
19	154/05	5/16" Spring Washer	63	130/10	3/8" Flat Washer
20	155/0514	5/16" BSF Socket Head Cap Screw 7/8" long	64	203/10L	3/8" BSF Self Locking Nut
21	319X.143	Link End	65	155/0614	3/8" BSF Socket Head Cap Screw 7/8" long
22	203/08	1/2" BSF Self Locking Nut	66	154/06	3/8" Spring Washer
23	155/0412	1/2" BSF Socket Head Cap Screw 3/4" long	67	319X.176	T Nut
24	203/04	1/4" BSF Self Locking Nut	68	-	Electro Magnetic Clutch
25	130/04	1/2" Flat Washer	69	156/224	2BA Socket Head Cap Screw 1 1/2" long
26	519X.194	Roller	70	154/03	3/16" Spring Washer
27	519X.133A	Roller Pin	71	219X.174	Switch Bracket
28	319V.119	Lever	72	167/0412	1/2" BSF Hexagon Head Set Screw 3/4" long
29	154/05	5/16" Spring Washer	73	198/8	1/4" Lock Washer
30	155/0514	5/16" BSF Socket Head Cap Screw 7/8" long	74	AW 12	Square D Limit Switch Class 9007
31	319X.176	Lever Pivot Pin	75	2441-D87-X1	Condulet Seal
32	101/2	1/2" External Circlip	76	BA-1	Square D Operating Arm
33	519X.144	Link Pin	77	167/0524	5/16" BSF Hexagon Head Set Screw 1 1/2" long
34	318X.249	Switch Bracket	78	203/05	5/16" BSF Self Locking Nut
35	130/04	1/2" Flat Washer	79	319V.222	Trip Bracket
36	203/04	1/4" BSF Self Locking Nut	80	319X.225	Spring Anchor
37	158/0412	1/2" BSF Counter Sunk Head Screw 3/4" long	81	203/05	5/16" BSF Self Locking Nut
38	318X.254	Restraining Arm	82	198/8	1/4" Lock Washer
39	319X.128	Switch Plate	83	167/0412	1/2" BSF Hexagon Head Set Screw 3/4" long
40	515X.144	Flexible Pipe Assembly	84	USE 325	Morris Spring
41	101/2	1/2" External Circlip	85	319X.123	Spring Anchor
42	319X.125	Lever	86	203/06	3/8" BSF Self Locking Nut
43	219V.135	Lever Boss	87	319X.520	Plug
44	121/1024T	5/16" Square Tapped Key 1 1/2" long			

List of Parts for
Plate No.21B

(Drawing No.31926A)

WHEN ORDERING SPARE PARTS ALWAYS QUOTE THE INSPECTION NUMBER OF THE MACHINE

CONTROL SHAFT ARRANGEMENT

2 1/4"-6, 2 1/4"-6D BAR MACHINES. 6 3/8"-6, 6 3/8"-6D CHUCKING MACHINES

Commencing
Machine No.16348
(Excluding Machine 19352)

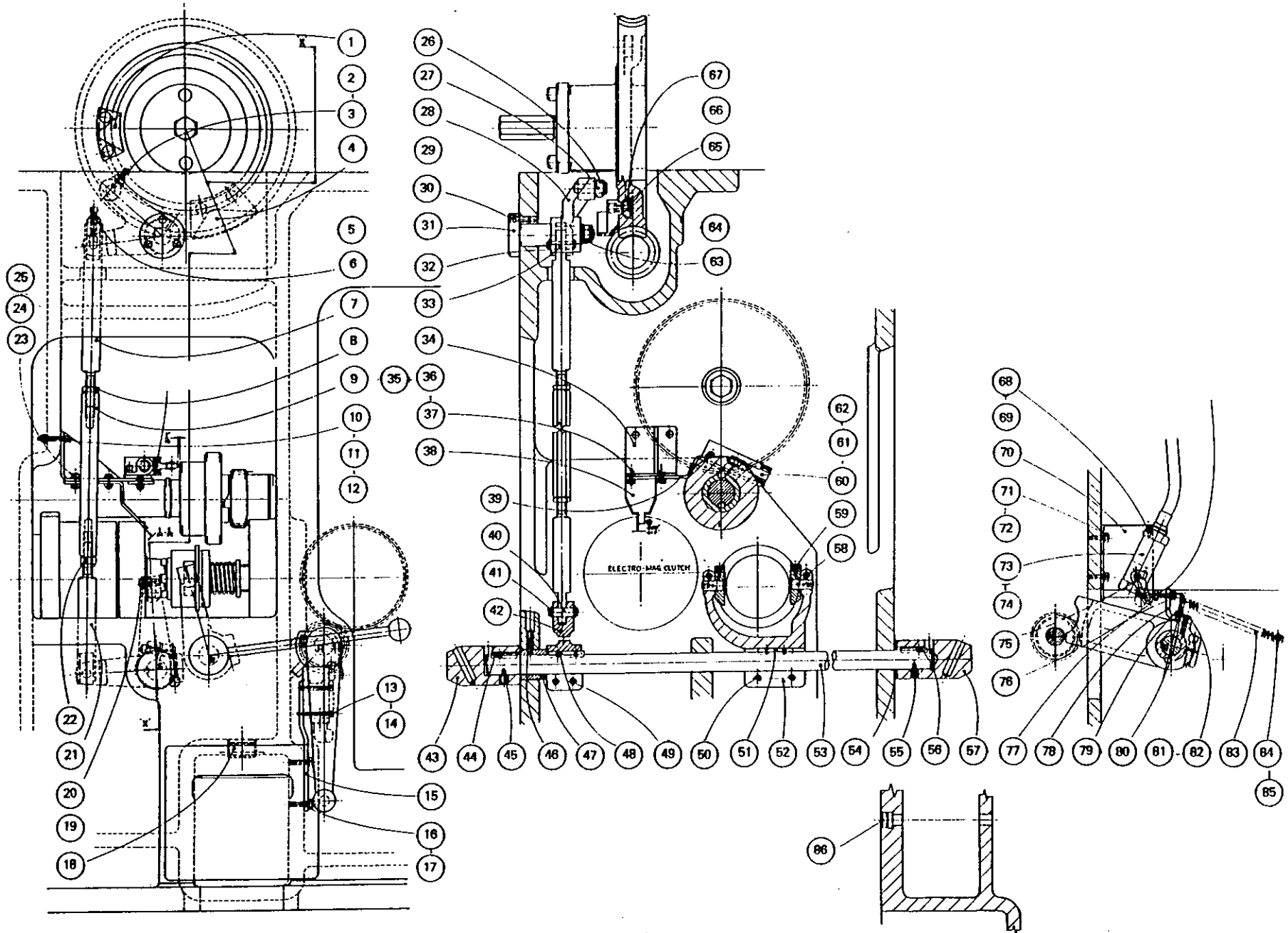

**WICKMAN
MULTI-SPINDLE
AUTOMATICS**

**MACHINE CONTROLS
6 $\frac{5}{8}$ "-6 AND 6 $\frac{5}{8}$ "-6D CHUCKING MACHINES**

INDEX NO.	PART NO.	TITLE.	INDEX NO.	PART NO.	TITLE.
1	203/06	$\frac{3}{8}$ " B.S.F. Self-Locking Nut.	24	182/0510	$\frac{1}{4}$ " B.S.F. Socket Set Screw, Taper Point, $\frac{1}{2}$ " long.
2	314X.123	Spring Anchor.	25	319X.138	Pull Rod Sleeve.
3	MSE.325	Morris Extension Spring.	26	319X.156	Trip Spring.
4	197/11	$\frac{1}{8}$ " dia. External Serrated Washer.	27	354/16	Oil Sealing "O" Ring for 1 $\frac{1}{8}$ " O.D.
5	167/0516H	$\frac{1}{8}$ " B.S.F. Hexagon Head Screw, 1" long.	28	319X.137	Pull Rod.
6	155/0514	$\frac{1}{8}$ " B.S.F. Socket Head Cap Screw, $\frac{1}{2}$ " long.	29	319X.155	Spring Sleeve.
7	154/05	$\frac{1}{4}$ " Spring Washer.	30	520X.178	Plunger Insert.
8	188/0644	$\frac{3}{8}$ " B.S.F. Square Head Set Screw, 2 $\frac{1}{4}$ " long.	31	154/4	Spring Washer for 4 B.A.
9	203/06L	$\frac{3}{8}$ " B.S.F. Self-Locking Nut (Thin).	32	174/4	4 B.A. Hexagon Nut.
10	154/06	$\frac{3}{8}$ " Spring Washer.	33	156/412	4 B.A. Socket Head Cap Screw, $\frac{1}{2}$ " long.
11	155/0620	$\frac{3}{8}$ " B.S.F. Socket Head Cap Screw, 1 $\frac{1}{2}$ " long.	34	50449	Crabtree 2-way Terminal Block.
12	354/14	Oil Sealing "O" Ring for $\frac{3}{4}$ " bore.	35	167/0508	$\frac{1}{8}$ " B.S.F. Hexagon Head Screw, $\frac{1}{2}$ " long.
13	508X.208	Spring Anchor.	36	154/05	$\frac{1}{4}$ " Spring Washer
14	146/317	Extension Spring.	37	173/05	$\frac{1}{4}$ " B.S.F. Hexagon Nut.
15	508X.208	Spring Anchor.	38	520V.175A	Varley Solenoid, Type "C".
16	167/0512H	$\frac{1}{8}$ " B.S.F. Hexagon Head Screw, $\frac{3}{4}$ " long.	39	319X.159	Solenoid Platform.
17	197/11	$\frac{1}{8}$ " dia. External Serrated Washer.	40	155/0512	$\frac{1}{8}$ " B.S.F. Socket Head Cap Screw, $\frac{3}{4}$ " long.
18	188/0540	$\frac{1}{8}$ " B.S.F. Square Head Set Screw, 2 $\frac{1}{4}$ " long.	41	130/05	$\frac{3}{16}$ " Flat Washer.
19	203/05	$\frac{1}{8}$ " B.S.F. Self-Locking Nut.	42	319X.146	Brake Operating Spring.
20	319X.141A	Stop Pin.	43	597BX.124	Fork Pin.
21	194/8	1" B.S.P. Socket Pipe Plug.	44	127/0605	$\frac{3}{32}$ " dia. Split Cotter Pin, $\frac{1}{2}$ " long.
22	241/13	1 $\frac{1}{2}$ " dia. Black Bakelite Knob.	45	319X.108A	Anchor Sleeve.
23	319X.140B	Latch Brake.	46	155/10120	$\frac{1}{4}$ " B.S.F. Socket Head Cap Screw, 7 $\frac{1}{2}$ " long.

List of Parts for
PLATE No. 22
(Drawing No. 319 Z 3)

WHEN ORDERING SPARE PARTS ALWAYS QUOTE THE SERIAL NUMBER OF THE MACHINE

MACHINE CONTROLS
6 $\frac{5}{8}$ "-6, 6 $\frac{5}{8}$ "-6D CHUCKING MACHINES

Last Used On
Machine No.14704 - 6 $\frac{5}{8}$ "-6
Machine No.15752 - 2 $\frac{1}{4}$ "-6

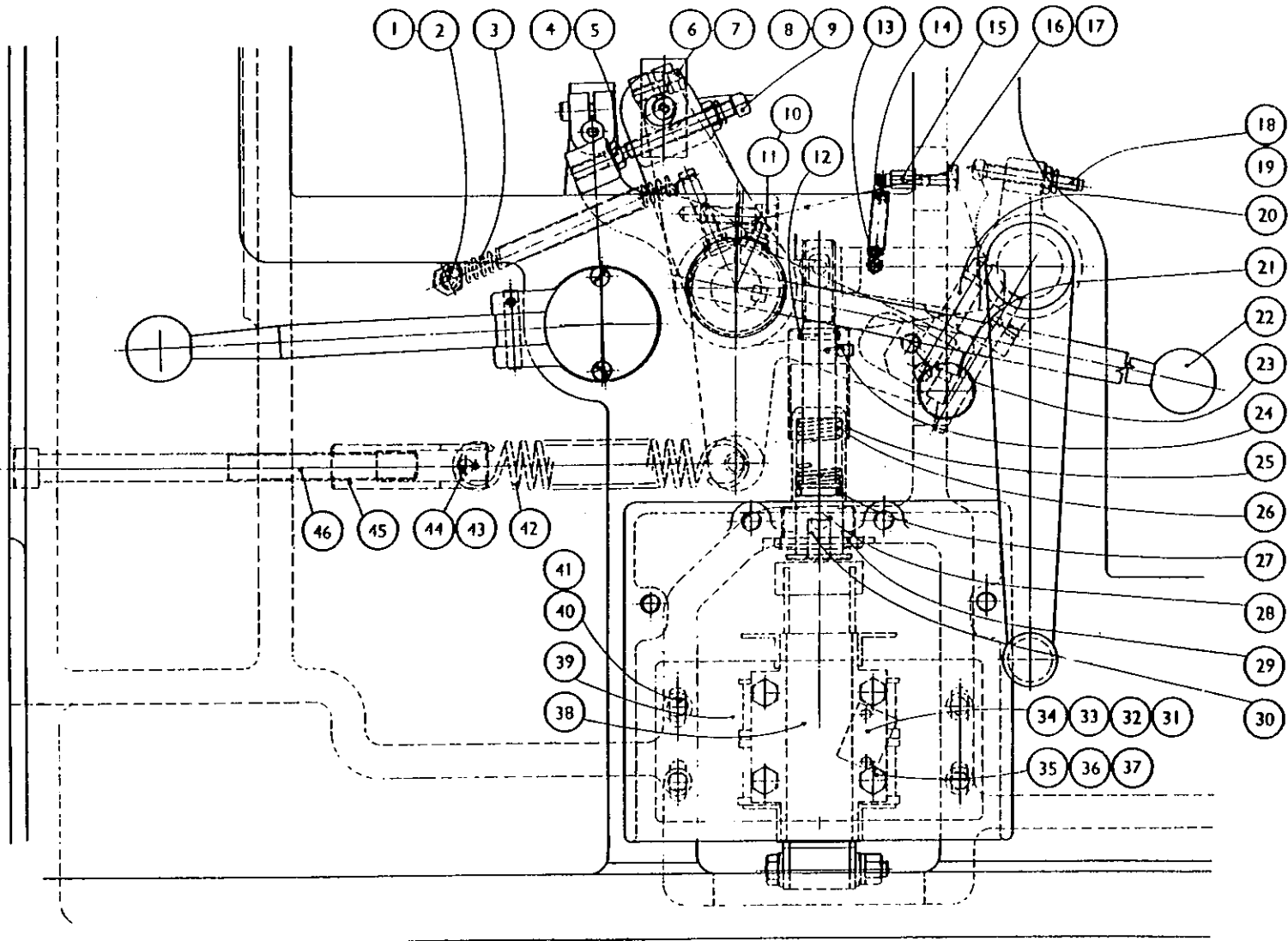

**WICKMAN
MULTI-SPINDLE
AUTOMATICS**

FEED BRAKE INTERLOCK

2¼" -6, 2¼" -6D BAR MACHINES

**Last Used On
M/c No.14704-6¼"-6
M/c No.15752-2¼"-6**

INDEX NO.	PART NO.	TITLE
1	198/8	Internal Shakeproof Washer
2	167/0412	¼" B.S.F. Hexagon Head Screw ¾" long
3	219X.174	Switch Bracket
4	203/05	5/16" B.S.F. Self Locking Nut
5	167/0536	5/16" Hexagon Head Screw 2¼" long
6	219X.173	Bracket
7	154/03	3/16" Spring Washer
8	156/224	2 B.A. Socket Cap Screw 1½" long
9	Class 9007	Type AW12-B1 Square D Limit Switch
10	155/0812	¼" B.S.F. Socket Cap Screw ¾" long
11	182/0832	½" B.S.F. Taper Point Set Screw 2" long

**List of Parts for
PLATE No.22A
(Drawing No.319Y4)**

WHEN ORDERING SPARE PARTS ALWAYS QUOTE THE SERIAL NUMBER OF THE MACHINE

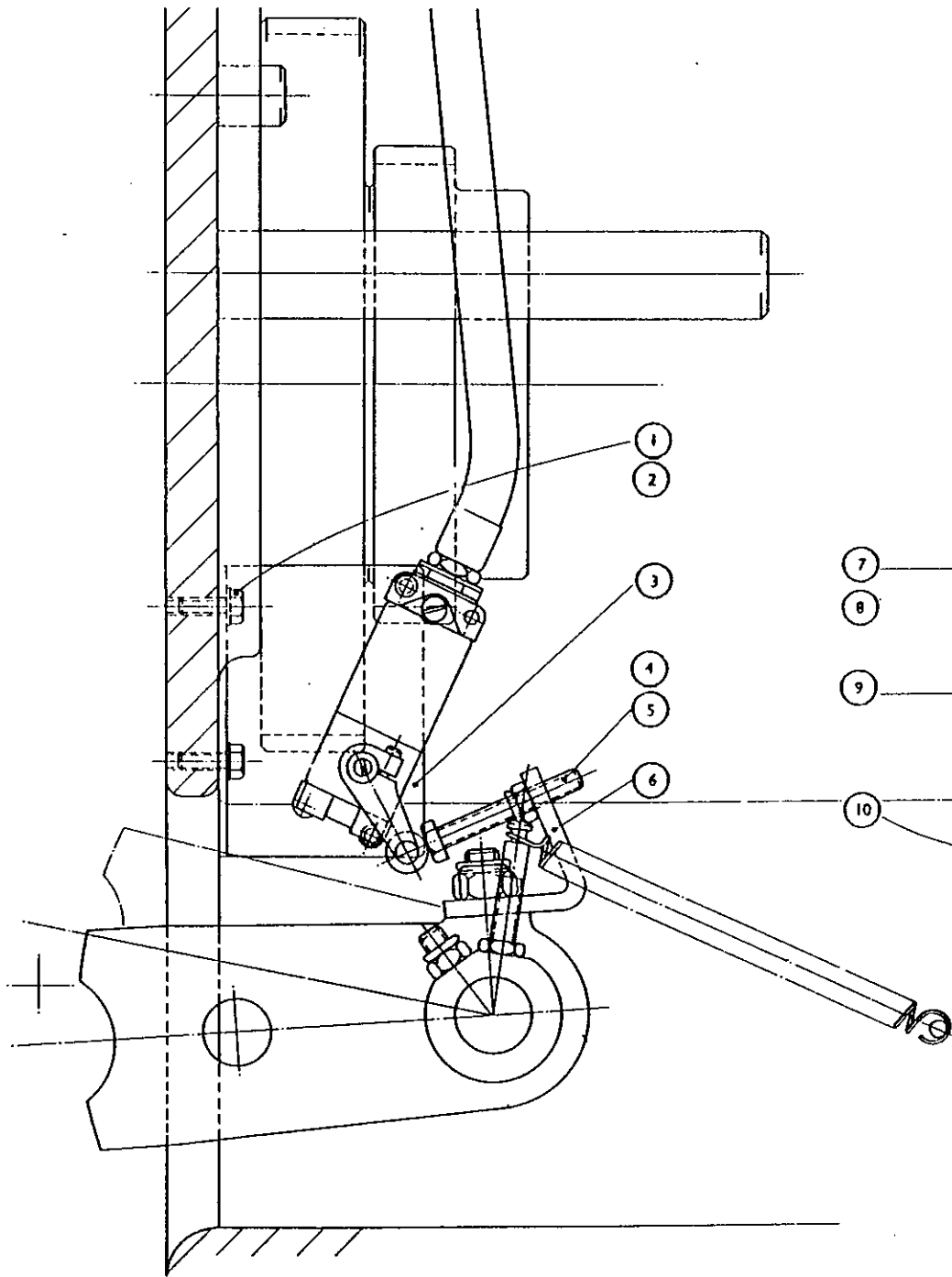

22A

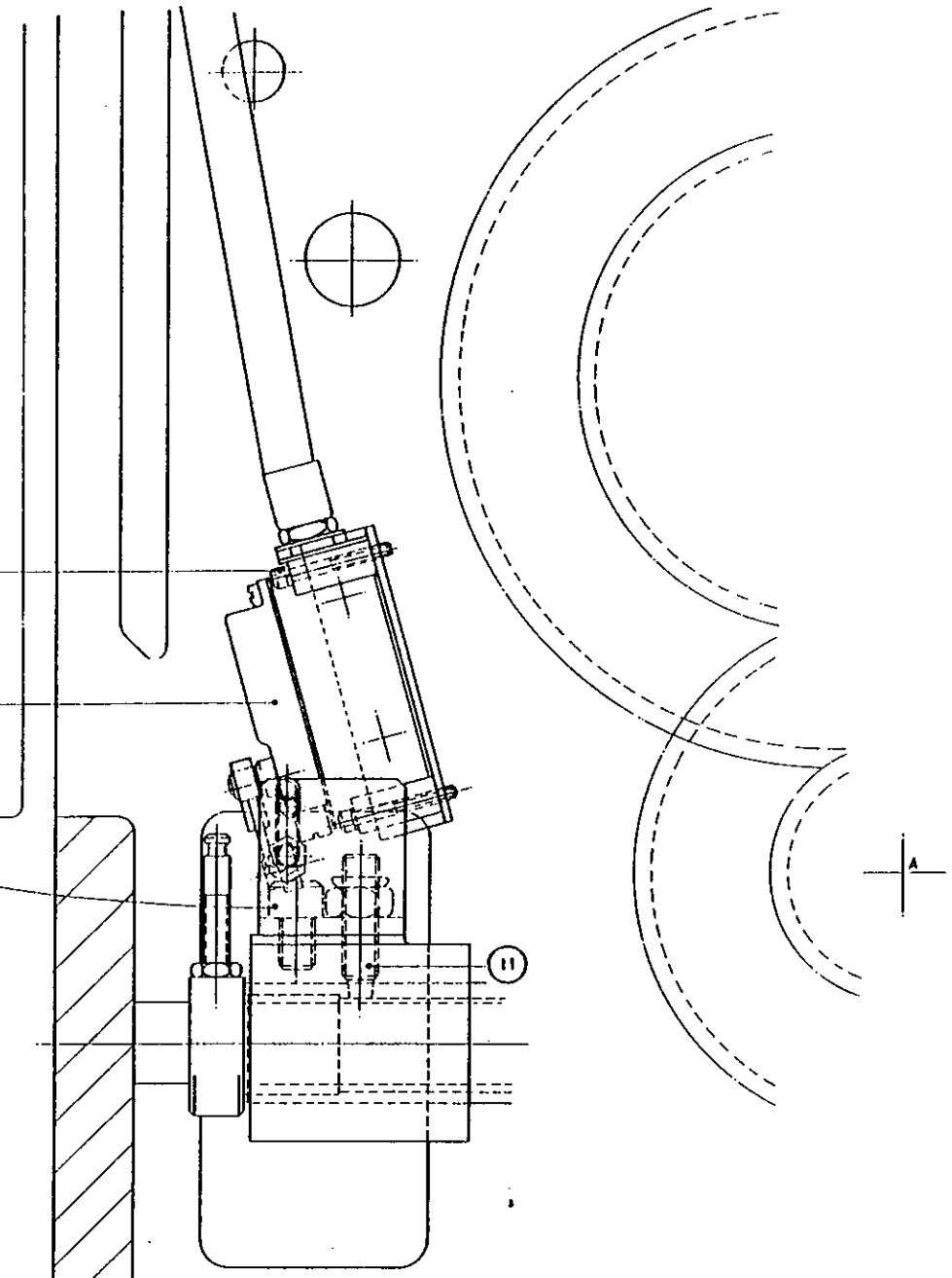

319 Y 4

**WICKMAN
MULTI-SPINDLE
AUTOMATICS**

CENTRE BLOCK OPERATION
2½"-6, 2¼"-6D, 2"-6 AND 2"-6D BAR MACHINES
6⅝"-6, 6⅜"-6D CHUCKING MACHINES

INDEX NO.	PART NO.	TITLE.	INDEX NO.	PART NO.	TITLE.
1	323X.169	Stop Shaft.	26	154/12	¾" Spring Washer.
2	323X.174	Toggle Bush.	27	155/1248	¾" B.S.F. Socket Head Cap Screw, 3" long.
3	324X.116	Roller Pin.	28	323V.160	Toggle Anchor.
4	324X.117	Cam Roller.	29	323X.172	Spacer.
5	323X.103	Roller Pin.	30	323X.171	Toggle Stop Bolt.
6	323X.104	Roller.	31	183/0620	¾" B.S.F. Socket Set Screw, Taper Point, 1¼" long.
7	323X.114	Link Pin.	32	203/06L	¾" B.S.F. Self-Locking Nut (Thin).
8	323X.113	Clamp.	33	323Y.119	Toggle Lever.
9	155/0828	¾" B.S.F. Socket Head Cap Screw, 1½" long.	34	183/0628	¾" B.S.F. Square Head Screw, Taper Point, 1¼" long.
10	154/08	¾" Spring Washer.	35	203/06	¾" B.S.F. Self-Locking Nut.
11	123X.178	Stop Pad.	36	323V.161	Toggle Link.
12	323X.140A	Stop Bolt.	37	203/06L	¾" B.S.F. Self-Locking Nut (Thin).
13	323Y.122	Centre Lever.	38	183/0620	¾" B.S.F. Square Head Screw, Taper Point, 1¼" long.
14	203/06L	¾" B.S.F. Self-Locking Nut (Thin).	39	225/4050	¾" Copper Tube, 1¼" long.
15	183/0620	¾" B.S.F. Square Head Screw, Taper Point, 1¼" long.	40	323Z.101	Sliding Block.
16	323X.162	Link Pin.	41	323X.162	Link Pin.
17	323Y.116	Link for Centre Cam Lever.	42	203/06L	¾" B.S.F. Self-Locking Nut (Thin).
18	203/06	¾" B.S.F. Self-Locking Nut.	43	183/0620	¾" B.S.F. Square Head Screw, Taper Point, 1¼" long.
19	183/0628	¾" B.S.F. Square Head Screw, Taper Point, 1¼" long.	44	323X.168	Toggle Pin.
20	210/2525	Yellow Indicator Washer.	45	323X.173	Toggle Bush.
21	212/18	¾" B.S.P. Autolub Nipple.	46	323X.174	Toggle Bush.
22	182/0620	¾" B.S.F. Socket Set Screw, Taper Point, 1¼" long.	47	323X.104	Roller.
23	323X.111	Stroke Setting Block.	48	541X.122	Approach Roller Pin.
24	323V.107A	Fulcrum Bracket.	49	323X.168	Toggle Pin.
25	323X.167	Dowel Pin.	50	323X.174	Toggle Bush.

List of Parts for
PLATE No. 23
(Drawing No. 323 Z I)

WHEN ORDERING SPARE PARTS ALWAYS QUOTE THE SERIAL NUMBER OF THE MACHINE

CENTRE BLOCK OPERATION

2¼"-6, 2¼"-6D, 2"-6 AND 2"-6D BAR MACHINES

6⅝"-6, 6⅝"-6D CHUCKING MACHINES

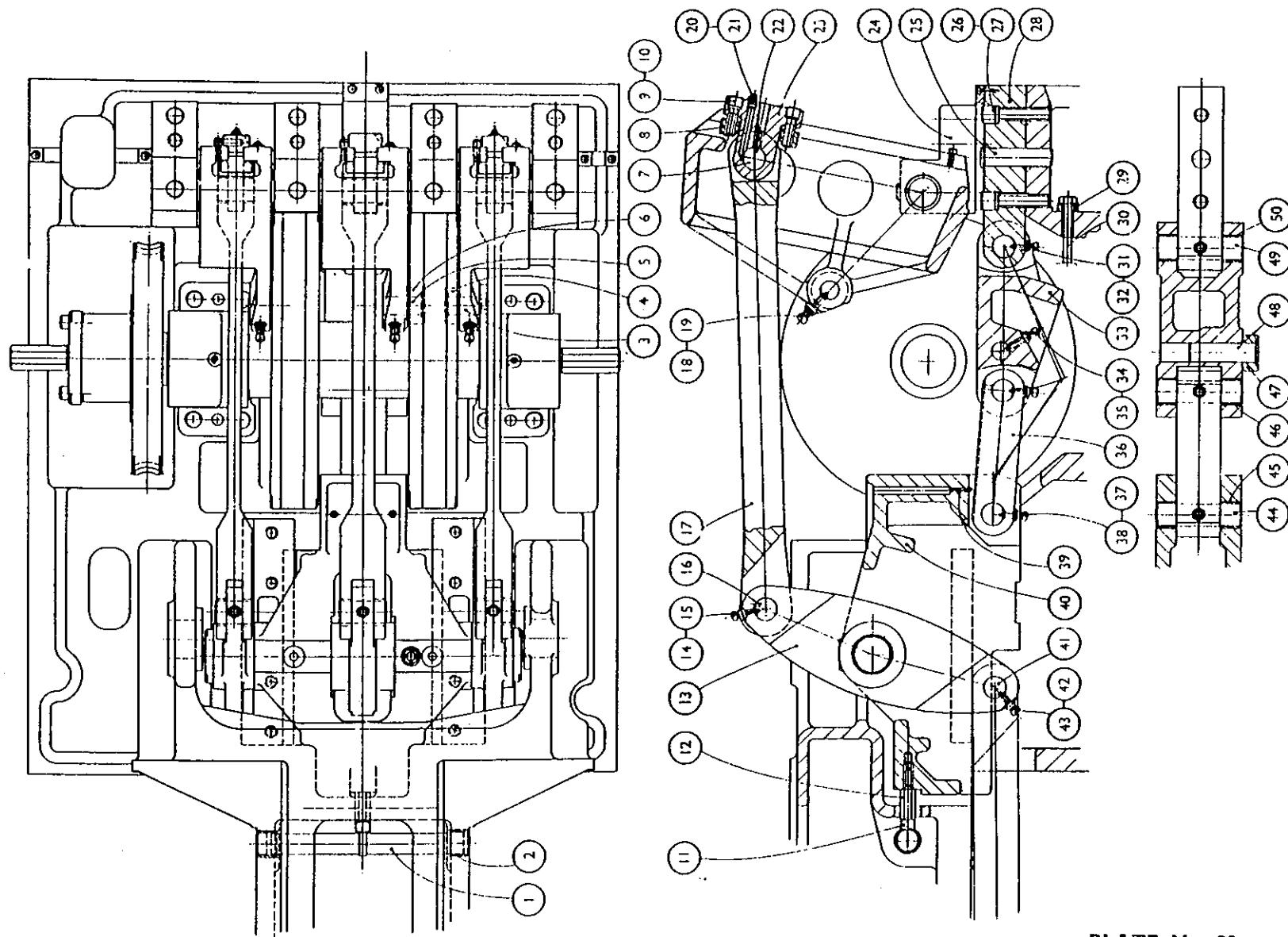

PLATE No. 23
(Drawing No. 323 Z 1)

**WICKMAN
MULTI-SPINDLE
AUTOMATICS**

CENTRE BLOCK OPERATION
2¼"-6, 2¼"-6D, 2"-6 AND 2"-6D BAR MACHINES
6⅜"-6, 6⅜"-6D CHUCKING MACHINES

INDEX NO.	PART NO.	TITLE.	INDEX NO.	PART NO.	TITLE.
1	324Y.119	Side Lever.	44	164/0408	¼" B.S.F. Round Head Set Screw, ½" long.
2	324X.120	Link Pin.	45	323V.105	Scale.
3	183/0620	⅜" B.S.F. Square Head Screw, Taper Point, 1½" long.	46	324X.106	Fulcrum Pin.
4	203/06L	⅜" B.S.F. Self-Locking Nut (Thin).	47	324Z.101	Independent Cam Lever, Front.
5	324Y.105	Link for Side Cam Levers.	48	324Y.112	Pusher Arm.
6	203/06	⅜" B.S.F. Self-Locking Nut.	49	164/0408	¼" B.S.F. Round Head Set Screw, ½" long.
7	183/0628	⅜" B.S.F. Square Head Screw, Taper Point, 1½" long.	50	323V.105	Scale.
8	324X.109	Link Pin.	51	154/12	⅜" Spring Washer.
9	324X.113	Clamp.	52	155/1280	⅜" B.S.F. Socket Head Cap Screw, 5" long.
10	155/0728	⅜" B.S.F. Socket Head Cap Screw, 1½" long.	53	323X.109	Fulcrum Pin.
11	154/07	⅜" Spring Washer.	54	323V.150	Retaining Strip.
12	212/18	⅜" B.S.P. Autolub Nipple.	55	154/10	⅜" Spring Washer.
13	210/2525	Yellow Indicator Washer.	56	155/1048	⅜" B.S.F. Socket Head Cap Screw, 3" long.
14	182/0620	⅜" B.S.F. Socket Set Screw, Taper Point, 1½" long.	57	325V.104	Feed Cam.
15	324X.104	Stroke Adjusting Block.	58	325V.105	Return Cam.
16	176/0404	⅜" B.S.F. Socket Set Screw, ½" long.	59	325V.106	Guard Cam.
17	NO.10	Taper Pin, 2½" long.	60	126/1620	½" dia. Dowel Pin, 1½" long.
18	155/1244	⅜" B.S.F. Socket Head Cap Screw, 2½" long.	61	122/2464T	Rectangular Key (Tapped), ⅜" x ½" x 4" long.
19	154/12	⅜" Spring Washer.	62	323X.126	Camshaft Bearing.
20	155/0512	⅜" B.S.F. Socket Head Cap Screw, ½" long.	63	323Y.130	Camshaft Bracket.
21	154/05	⅜" Spring Washer.	64	318Y.125	Upper Worm Wheel.
22	323X.108	Fulcrum Bracket Tenon.	65	323X.128	Clamp Plate.
23	323V.123	Lever Shaft.	66	323X.127	Clamp Pillar.
24	236/323624	Oil Retaining Bush.	67	155/0828	⅜" B.S.F. Socket Head Cap Screw, 1½" long.
25	323X.115	Link Bush.	68	154/08	⅜" Spring Washer.
26	183/0832	⅜" B.S.F. Square Head Screw, Taper Point, 2" long.	69	141/20	⅜" dia. Taper Pin (Tapped), 2½" long.
27	203/08	⅜" B.S.F. Self-Locking Nut.	70	323Y.153	Rear Cam Carrier.
28	324X.115	Link Bush.	71	126/2028	⅜" dia. Dowel Pin, 1½" long.
29	236/323636	Oil Retaining Bush.	72	323Y.152	Front Cam Carrier.
30	324X.121	Retaining Plate.	73	155/0616	⅜" B.S.F. Socket Head Cap Screw, 1" long.
31	155/0616	⅜" B.S.F. Socket Head Cap Screw, 1" long.	74	323Y.124	Upper Camshaft.
32	143/1020D	⅜" dia. Mills Grooved Pin, 1½" long.	75	324V.124	Guard Cam.
33	155/0632	⅜" B.S.F. Socket Head Cap Screw, 2" long.	76	324V.123	Return Cam.
34	154/06	⅜" Spring Washer.	77	324V.122	Feed Cam
35	223X.130	Stop.	78	323Y.180	Centre Block, Feed Cam.
36	143/1224D	⅜" dia. Mills Grooved Pin, 1½" long.	79	323V.181	Centre Block, Return Cam.
37	155/0510	⅜" B.S.F. Socket Head Cap Screw, ½" long.	80	323V.188	Centre Block, Guard Cam.
38	154/05	⅜" Spring Washer.	81	323V.182	4" Fast Motion Cam, Inner
39	154/10	⅜" Spring Washer.	82	323V.183	4" Fast Motion Cam, Outer
40	155/1036	⅜" B.S.F. Socket Head Cap Screw, 2½" long.	83	323V.185	3½" Fast Motion Inner Cam.
41	325Z.101	Independent Cam Lever, Rear.	84	323V.186	3½" Fast Motion Outer Cam.
42	323X.110	Fulcrum Bush.	85	323V.184	Fast Motion Guard Cam.
43	323Z.102	Centre Cam Lever.	86	155/0820	⅜" B.S.F. Socket Head Cap Screw, 1½" long.

List of Parts for
PLATE No. 24
(Drawing No. 323 Z 2)

WHEN ORDERING SPARE PARTS ALWAYS QUOTE THE SERIAL NUMBER OF THE MACHINE

CENTRE BLOCK OPERATION

2¼"-6, 2¼"-6D, 2"-6 AND 2"-6D BAR MACHINES

6½"-6, 6½"-6D CHUCKING MACHINES

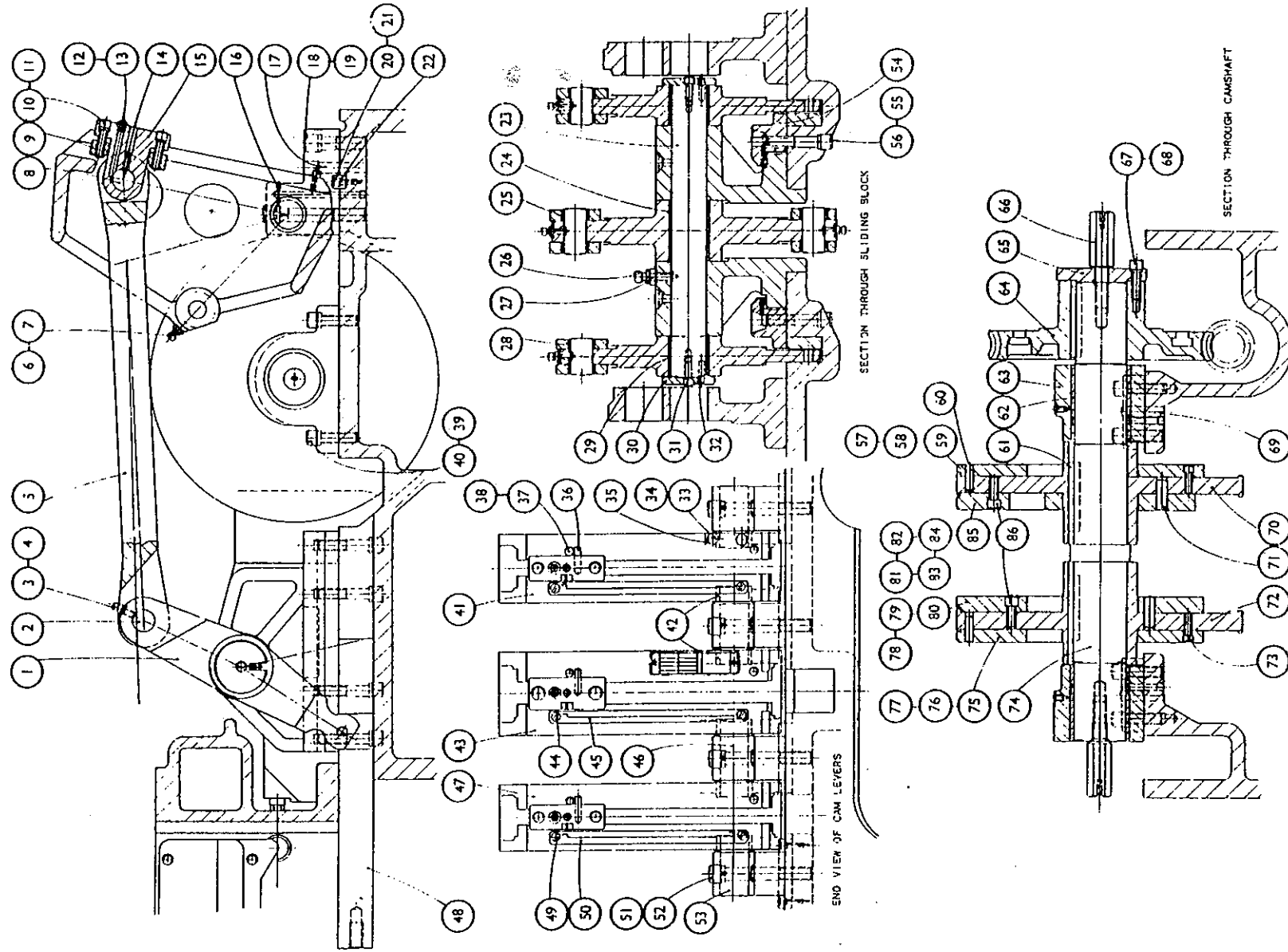

**WICKMAN
MULTI-SPINDLE
AUTOMATICS**

AUXILIARY LONGITUDINAL SLIDE OPERATION. FRONT AND REAR

2¼"-6, 2¼"-6D, 2"-6 AND 2"-6D BAR MACHINES

6⅝"-6, 6⅝"-6D CHUCKING MACHINES

INDEX NO.	PART NO.	TITLE.	INDEX NO.	PART NO.	TITLE.
1	324Y.151	Lever.	23	189AX.129	Spring Anchor.
2	325Y.151	Lever.	24	203/06L	¾" B.S.F. Self-Locking Nut (Thin).
3	325Y.150	Cam Lever.	25	182/0620	¾" B.S.F. Socket Set Screw, Taper Point, 1¼" long.
4	324X.106	Fulcrum Pin.	26	324V.153	Link.
5	323X.110	Fulcrum Bush.	27	324X.155A	Tension Spring.
6	324Y.150	Cam Lever.	28	189AX.129	Spring Anchor.
7	341X.119	Tee Bolt.	29	183/0624	¾" B.S.F. Square Head Set Screw, 1¼" long.
8	341X.141	Sliding Sleeve.	30	203/06L	¾" B.S.F. Self-Locking Nut (Thin).
9	236/242816	Oil Retaining Bush.	31	164/0406	¾" B.S.F. Round Head Screw, ¾" long.
10	341X.116	Slotted Washer.	32	541X.118	Indicating Pin.
11	173/14HL	¾" B.S.F. Locknut.	33	324X.154	Scale.
12	323X.110	Fulcrum Bush.	34	155/1280	¾" B.S.F. Socket Head Cap Screw, 5" long.
13	323X.109	Fulcrum Pin.	35	154/12	¾" Spring Washer.
14	324X.117	Cam Roller.	36	176/0404	¾" B.S.F. Socket Set Screw, ¾" long.
15	323X.103	Roller Pin.	37	323V.107A	Fulcrum Bracket.
16	236/202412	Oil Retaining Bush.	38	155/1244	¾" B.S.F. Socket Head Cap Screw, 2¼" long.
17	323X.162	Link Pin.	39	154/12	¾" Spring Washer.
18	324X.152	Lever Pivot.	40	NO.10	Taper Pin, 2¼" long.
19	212/03GS	¾" B.S.P. Oiler.	41	155/0512	¾" B.S.F. Socket Head Cap Screw, ¾" long.
20	154/06	¾" Spring Washer.	42	154/05	¾" Spring Washer.
21	155/0616	¾" B.S.F. Socket Head Cap Screw, 1" long.	43	323X.108	Fulcrum Bracket.
22	236/323640	Oil Retaining Bush.	44	324Y.112	Pusher Arm.

List of Parts for
PLATE No. 25
(Drawing No. 324 Z 1)

WHEN ORDERING SPARE PARTS ALWAYS QUOTE THE SERIAL NUMBER OF THE MACHINE

AUXILIARY LONGITUDINAL SLIDE OPERATION. FRONT AND REAR

2¼"-6, 2¼"-6D, 2"-6 AND 2"-6D BAR MACHINES

6⅝"-6, 6⅝"-6D CHUCKING MACHINES

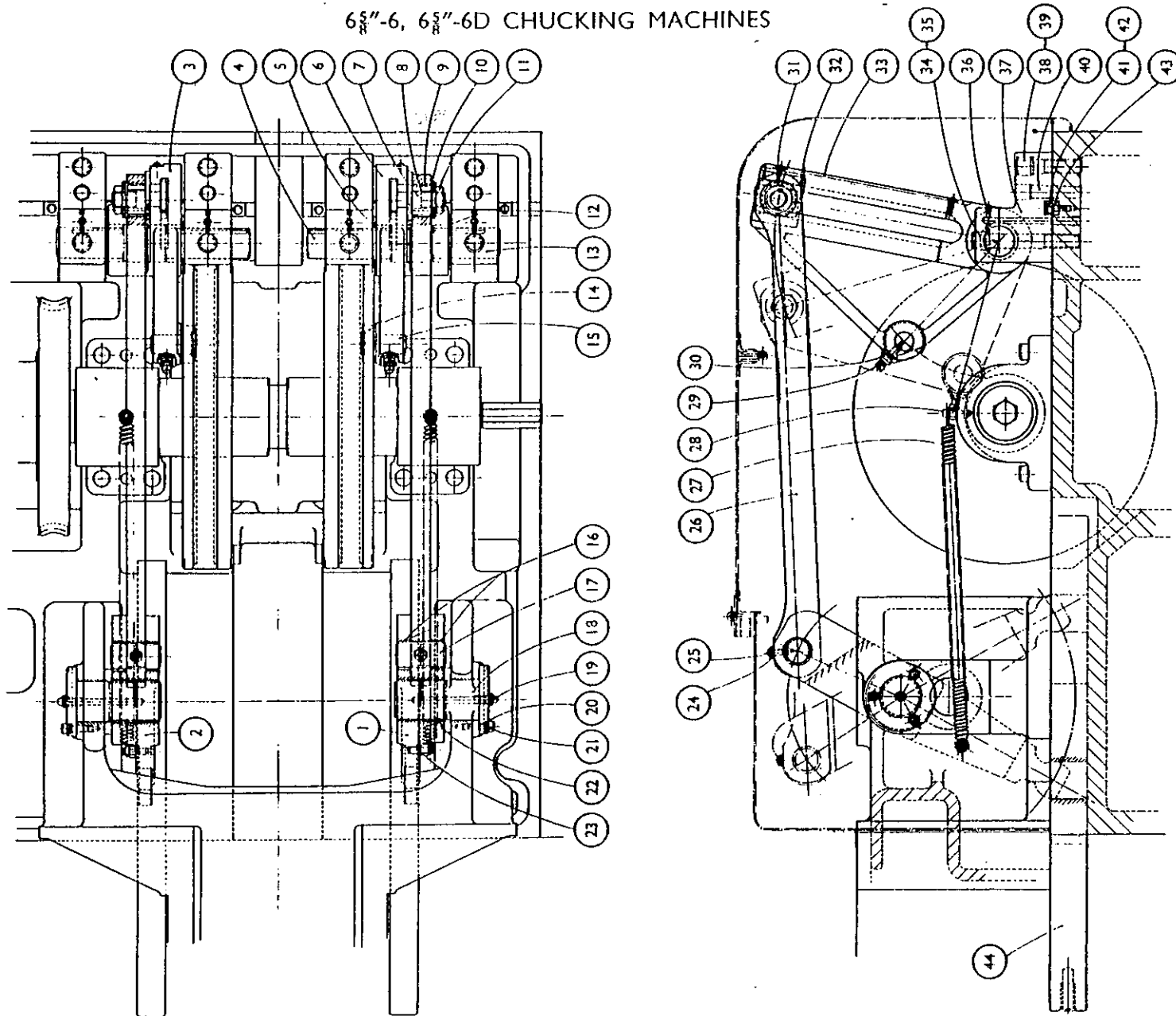

PLATE No. 25
(Drawing No. 324 Z 1)

**WICKMAN
MULTI-SPINDLE
AUTOMATICS**

CENTRE BLOCK

2¼"-6, 2¼"-6D, 2"-6 AND 2"-6D BAR MACHINES

INDEX NO.	PART NO.	TITLE.	INDEX NO.	PART NO.	TITLE.
1	154/04	¼" Spring Washer.	44	155/0408	¼" B.S.F. Socket Head Cap Screw, ½" long.
2	155/0414	¼" B.S.F. Socket Head Cap Screw, ¾" long.	45	154/04	¼" Spring Washer.
3	178/0516	½" B.S.F. Socket Set Screw, ¼-Dog Point, 1" long.	46	327X.126	Swarf Guard—Centre Guide.
4	129X.105	Locating Block.	47	155/0408	¼" B.S.F. Socket Head Cap Screw, ½" long.
5	129X.105	Locating Block.	48	154/04	¼" Spring Washer.
6	178/0516	½" B.S.F. Socket Set Screw, ¼-Dog Point, 1" long.	49	327X.127	Swarf Guard—Beam.
7	155/0414	¼" B.S.F. Socket Head Cap Screw, ¾" long.	50	527X.116	Packing Washer.
8	154/04	¼" Spring Washer.	51	154/03	¼" Spring Washer.
9	329X.113	Guard Plate, Rear.	52	156/210	2 B.A. Socket Head Cap Screw, ½" long.
10	154/07	¼" Spring Washer.	53	527X.125	Oil Filter.
11	155/0732	¼" B.S.F. Socket Head Cap Screw, 2" long.	54	155/1040	¼" B.S.F. Socket Head Cap Screw, 2¼" long.
12	329X.109A	Stop Block.	55	154/10	¼" Spring Washer.
13	329X.112	Guard Plate, Front.	56	327V.105	Guide Block.
14	173/08HL	½" B.S.F. Hexagon Locknut.	57	323X.162	Link Pin.
15	329X.111A	Stop Screw.	58	182/0620	½" B.S.F. Socket Set Screw, Taper Point, 1¼" long.
16	329X.107	Adjusting Screw.	59	225/4050	Copper Tube.
17	FX.2599	Hexagon Nut.	60	155/0412	¼" B.S.F. Socket Head Cap Screw, ½" long.
18	130/12	¼" Plain Washer.	61	154/04	¼" Spring Washer.
19	529X.110	Spacer.	62	203/10L	¼" B.S.F. Self-Locking Nut.
20	FX.2599	Hexagon Nut.	63	327X.130	Gasket.
21	173/08H	½" B.S.F. Hexagon Nut.	64	173/10HL	½" B.S.F. Hexagon Locknut.
22	173/08HL	½" B.S.F. Hexagon Locknut.	65	327V.128	Splash Guard.
23	130/12	¼" Plain Washer.	66	327Y.120	Centre Block Link.
24	154/08	¼" Spring Washer.	67	527X.111B	Stop Screw.
25	155/0832	¼" B.S.F. Socket Head Cap Screw, 2" long.	68	327Z.102	Guide Arm.
26	329X.106	Extension Arm.	69	173/10H	½" B.S.F. Hexagon Nut.
27	FX.4539C	Gib Adjusting Screw.	70	173/10HL	½" B.S.F. Hexagon Locknut.
28	530X.105	Gib Strip.	71	154/10	¼" Spring Washer.
29	329Y.102	Tool Block Guide.	72	155/1068	¼" B.S.F. Socket Head Cap Screw, 4¼" long.
30	329Y.101	Tool Block.	73	327X.103	Centre Block Bush.
31	176/0516	½" B.S.F. Socket Set Screw, Cup Point, 1" long.	74	141/17	Extractable Taper Dowel.
32	527X.106A	Gib Strip.	75	194/1	¼" B.S.P. Socket Pipe Plug.
33	327X.107	Gib Adjusting Screw.	76	527X.115	Dowel for Bearing.
34	329Y.102	Tool Block Guide.	77	14.75.0602	Elbow.
35	530X.105	Gib Strip.		14.07.06	Tubing Nut.
36	FX.4539C	Gib Adjusting Screw.		14.08.06	Tubing Sleeve.
37	329Y.101	Tool Block.	78	194/1	¼" B.S.P. Socket Pipe Plug.
38	329X.106	Extension Arm.	79	327Z.101	Centre Block.
39	153/05	Soft Pad.	80	527X.115	Dowel for Bearing.
40	155/1060	½" B.S.F. Socket Head Cap Screw, 3¼" long.	81	327X.103	Centre Block Bush.
41	154/10	¼" Spring Washer.	82	327X.113	Scraper Ring.
42	158/0410	¼" B.S.F. Countersunk Socket Screw, ½" long.	83	327X.114	Retaining Plate.
43	14.75.0602	Elbow.			
	14.07.06	Tubing Nut.			
	14.08.06	Tubing Sleeve.			

List of Parts for
PLATE No. 26
(Drawing No. 327 Z 1)

WHEN ORDERING SPARE PARTS ALWAYS QUOTE THE SERIAL NUMBER OF THE MACHINE

CENTRE BLOCK

2 1/4"-6, 2 1/4"-6D, 2"-6 AND 2"-6D BAR MACHINES

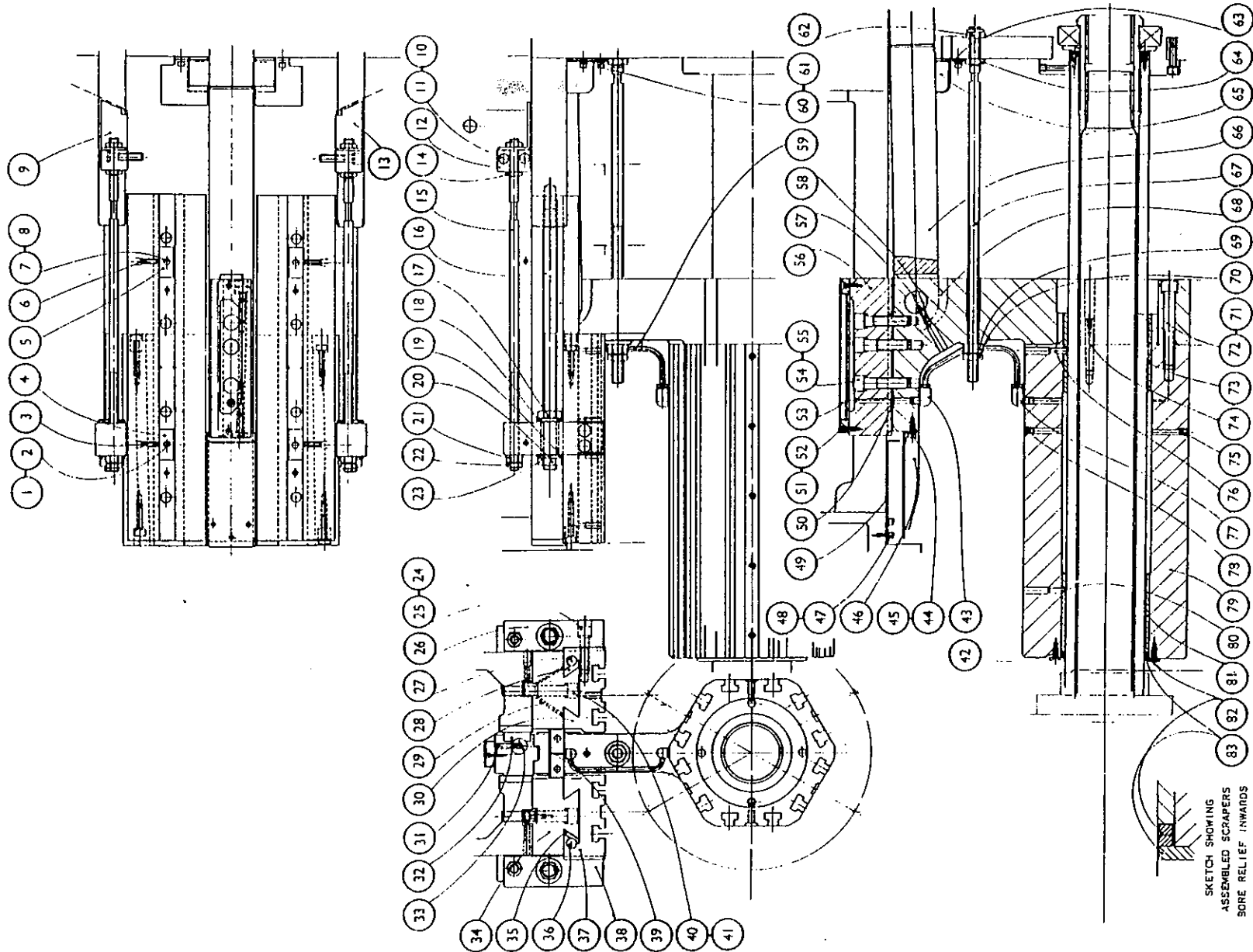

**WICKMAN
MULTI-SPINDLE
AUTOMATICS**

**CENTRE BLOCK
6 $\frac{1}{8}$ "-6 AND 6 $\frac{1}{8}$ "-6D CHUCKING MACHINES**

INDEX NO.	PART NO.	TITLE.	INDEX NO.	PART NO.	TITLE.
1	155/0414	$\frac{1}{4}$ " B.S.F. Socket Head Cap Screw, $\frac{3}{4}$ " long.	46	327V.122	Centre Block Link, L.H.
2	154/04	$\frac{1}{4}$ " Spring Washer.	47	161/0616	$\frac{1}{4}$ " B.S.F. Slotted Countersunk Screw, 1" long.
3	173/0516	$\frac{3}{8}$ " B.S.F. Socket Set Screw, $\frac{1}{4}$ -Dog Point, 1" long.	48	327X.125A	Link Stop.
4	129X.105	Locating Block.	49	323X.162	Link Pin.
5	329X.109A	Stop Block.	50	182/0620	$\frac{1}{4}$ " B.S.F. Socket Set Screw, Taper Point, 1 $\frac{1}{4}$ " long.
6	155/0732	$\frac{3}{8}$ " B.S.F. Socket Head Cap Screw, 2" long.	51	327V.105	Guide Block.
7	154/07	$\frac{1}{4}$ " Spring Washer.	52	154/10	$\frac{1}{4}$ " Spring Washer.
8	154/04	$\frac{1}{4}$ " Spring Washer.	53	155/1040	$\frac{1}{4}$ " B.S.F. Socket Head Cap Screw, 2 $\frac{1}{2}$ " long.
9	155/0412	$\frac{1}{4}$ " B.S.F. Socket Head Cap Screw, $\frac{3}{4}$ " long.	54	527X.125	Oil Filter.
10	329X.113	Guard Plate, Rear.	55	156/210	2 B.A. Socket Head Cap Screw, $\frac{1}{4}$ " long.
11	327X.131	Splash Guard.	56	154/03	$\frac{1}{4}$ " Spring Washer.
12	327X.130	Gasket.	57	327X.127	Swarf Guard, Beam.
13	173/08HL	$\frac{1}{4}$ " B.S.F. Hexagon Locknut.	58	155/0408	$\frac{1}{4}$ " B.S.F. Socket Head Cap Screw, $\frac{1}{4}$ " long.
14	329X.111A	Stop Screw.	59	154/04	$\frac{1}{4}$ " Spring Washer.
15	130/07	$\frac{1}{4}$ " Flat Washer.	60	327X.126	Swarf Guard, Centre Guide.
16	329X.112	Guard Plate, Front.	61	527X.116	Packing Washer.
17	327X.124	Link Bolt.	62	155/0408	$\frac{1}{4}$ " B.S.F. Socket Head Cap Screw, $\frac{1}{4}$ " long.
18	329X.107	Adjusting Screw.	63	154/04	$\frac{1}{4}$ " Spring Washer.
19	FX.2599	Hexagon Nut.	64	158/0410	$\frac{1}{4}$ " B.S.F. Socket Countersunk Screw, $\frac{1}{4}$ " long.
20	130/12	$\frac{1}{4}$ " Flat Washer.	65	527X.115	Oil Filter.
21	529X.110	Spacer.			Elbow.
22	130/12	$\frac{1}{4}$ " Flat Washer.	66	{ 14.75.0602	Tubing Nut.
23	173/08H	$\frac{1}{4}$ " B.S.F. Hexagon Nut.		{ 14.07.06	Tubing Sleeve.
24	173/08HL	$\frac{1}{4}$ " B.S.F. Hexagon Locknut.		{ 14.08.06	
25	FX.2599	Hexagon Nut.	67	203/10L	$\frac{1}{4}$ " B.S.F. Self-Locking Nut.
26	329X.106	Extension Arm.	68	173/10HL	$\frac{1}{4}$ " B.S.F. Hexagon Locknut.
27	155/0832	$\frac{1}{4}$ " B.S.F. Socket Head Cap Screw, 2" long.	69	527X.111B	Stop Screw.
28	154/08	$\frac{1}{4}$ " Spring Washer.	70	327Z.102	Guide Arm.
29	FX.4539C	Gib Adjusting Screw.	71	173/10H	$\frac{1}{4}$ " B.S.F. Hexagon Nut.
30	530X.105	Gib Strip.	72	173/10HL	$\frac{1}{4}$ " B.S.F. Hexagon Locknut.
31	329Y.102	Tool Block Guide.	73	155/1068	$\frac{1}{4}$ " B.S.F. Socket Head Cap Screw, 4 $\frac{1}{4}$ " long.
32	155/1060	$\frac{1}{4}$ " B.S.F. Socket Head Cap Screw, 3 $\frac{1}{2}$ " long.	74	154/10	$\frac{1}{4}$ " Spring Washer.
33	154/10	$\frac{1}{4}$ " Spring Washer.	75	327X.103	Centre Block Bush.
34	527X.106A	Gib Strip.	76	141/17	Extractable Taper Dowel.
35	176/0516	$\frac{3}{8}$ " B.S.F. Socket Set Screw, Cup Point, 1" long.	77	527X.115	Dowel for Bearing.
36	153/05	Soft Pad.	78	194/1	$\frac{1}{4}$ " B.S.P. Socket Pipe Plug.
37	327X.107	Gib Adjusting Screw.	79	225/4050	Copper Tube.
38	329X.106	Extension Arm.			Elbow.
39	329Y.102	Tool Block Guide.	80	{ 14.75.0602	Tubing Nut.
40	FX.4539C	Gib Adjusting Screw.		{ 14.07.06	Tubing Sleeve.
41	530X.105	Gib Strip.		{ 14.08.06	
42	329Y.101	Tool Block.	81	194/1	$\frac{1}{4}$ " B.S.P. Socket Pipe Plug.
43	329Y.101	Tool Block.	82	327Z.121	Centre Block (6 $\frac{1}{8}$ "-6 only).
44	327V.129	Centre Block Link, R.H.	83	327Z.132	Centre Block (6 $\frac{1}{8}$ "-6D only).
45	327X.123	Link Adjuster.	84	327X.103	Centre Block Bush.
			85	327X.113	Scraper Ring.
			86	327X.114	Retaining Plate.

List of Parts for
PLATE No. 27
(Drawing No. 327 Z 2)

WHEN ORDERING SPARE PARTS ALWAYS QUOTE THE SERIAL NUMBER OF THE MACHINE

CENTRE BLOCK

6 $\frac{5}{8}$ "-6, 6 $\frac{5}{8}$ "-6D CHUCKING MACHINES

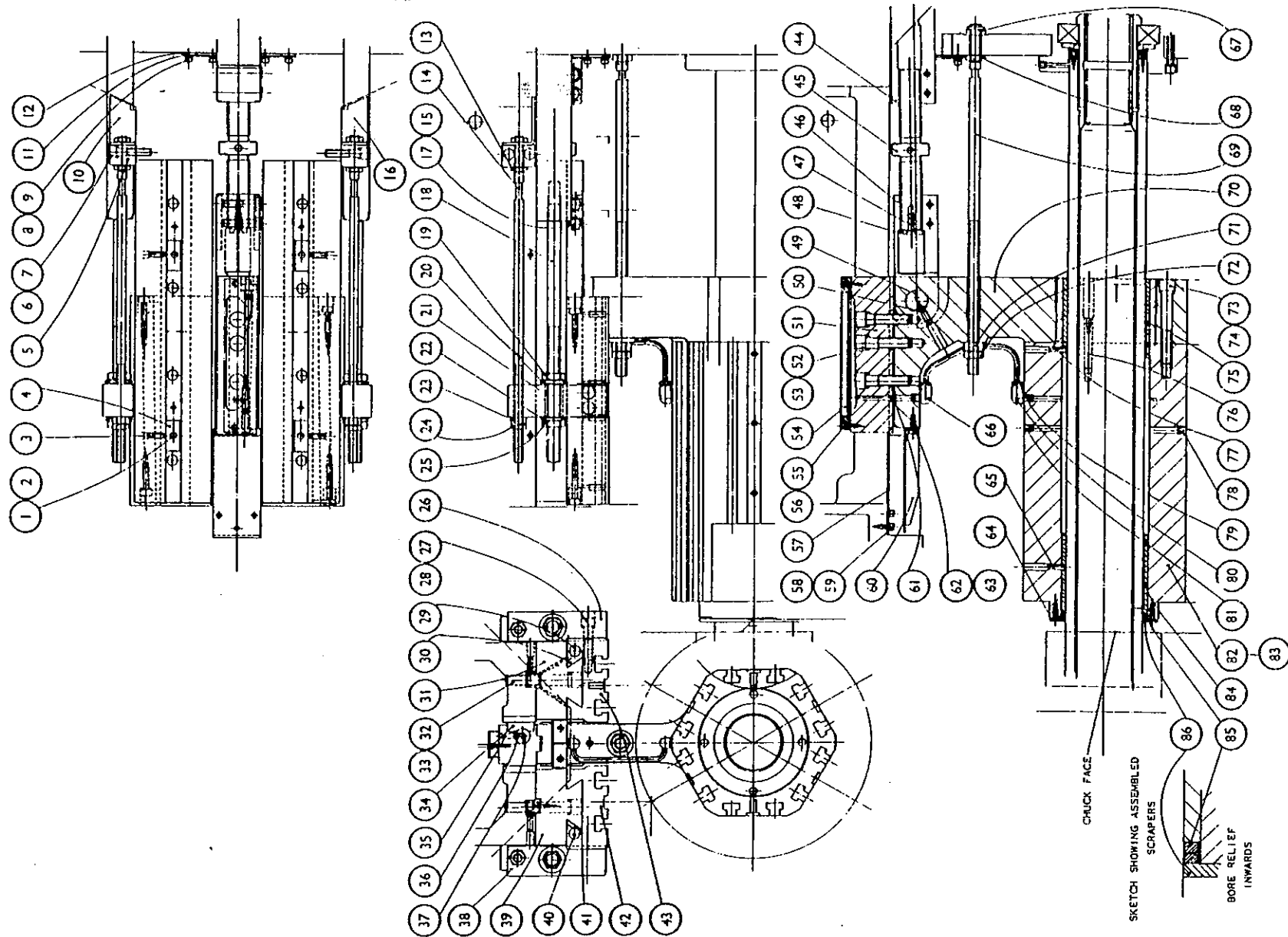

PLATE No. 27
(Drawing No. 327 Z 2)

**WICKMAN
MULTI-SPINDLE
AUTOMATICS**

UPPER CROSS SLIDES
2 $\frac{1}{4}$ "-6, 2 $\frac{1}{4}$ "-6D, 2"-6 AND 2"-6D BAR MACHINES
6 $\frac{5}{8}$ "-6, 6 $\frac{5}{8}$ "-6D CHUCKING MACHINES

INDEX NO.	PART NO.	TITLE.	INDEX NO.	PART NO.	TITLE.
1	155/0616	$\frac{3}{8}$ " B.S.F. Socket Head Cap Screw, 1" long.	26	125/1628	$\frac{1}{4}$ " dia. Taper Pin, 1 $\frac{1}{2}$ " long.
2	154/06	$\frac{3}{8}$ " Spring Washer.	27	167/1048H	$\frac{1}{8}$ " B.S.F. Hexagon Head Set Screw, 3" long (Hardened).
3	141/3	$\frac{3}{16}$ " dia. Extractable Taper Pin, 1 $\frac{1}{2}$ " long.	28	130/10	$\frac{1}{8}$ " dia. Plain Washer.
4	335X.106	End Bracket.	29	335Z.129	Upper Cross Slide (2"-6 only).
5	129/13	1" dia. Welch Plug.		335Z.132	Upper Cross Slide (Front) (6 $\frac{5}{8}$ "-6 only).
6	342V.112/E	Micrometer Head.	30	335X.136	Link Pin.
7	342V.112/M	Micrometer Head.	31	236/141612	Oil Retaining Bush.
8	342X.139	Adjusting Screw.	32	342X.122	Stop Bracket Lockbolt.
9	335V.135	Adjusting Block.	33	342X.126	Plain Locking Piece.
10	335X.137	Link.	34	342X.125	Threaded Locking Piece.
11	335V.120	Operating Arm.	35	155/0824	$\frac{1}{4}$ " B.S.F. Socket Head Cap Screw, 1 $\frac{1}{2}$ " long.
12	155/0728	$\frac{1}{4}$ " B.S.F. Socket Head Cap Screw, 1 $\frac{1}{2}$ " long.	36	154/08	$\frac{1}{4}$ " Spring Washer.
13	154/07	$\frac{1}{4}$ " Spring Washer.	37	130/14	$\frac{3}{8}$ " dia. Plain Washer.
14	155/0840	$\frac{1}{2}$ " B.S.F. Socket Head Cap Screw, 2 $\frac{1}{2}$ " long.	38	203/14L	$\frac{3}{8}$ " B.S.F. Self-Locking Nut (Thin).
15	154/08	$\frac{1}{2}$ " Spring Washer.	39	335Y.119	Keyed Upper Lever.
16	335X.109	Upper Cross Slide Spring.	40	335X.128	Pivot Pin.
17	335X.110	Spring Support.	41	335V.125	Operating Shaft.
18	335Z.129	Upper Cross Slide (2"-6 only).	42	335X.138	Operating Arm Key.
	335Z.131	Upper Cross Slide (Rear) (6 $\frac{5}{8}$ "-6 only).	43	143/0616A	$\frac{3}{16}$ " dia. Mills Grooved Pin, 1" long.
19	335X.122A	Stop Bracket	44	236/364440	Oil Retaining Bush.
			45	156/208	2 B.A. Socket Head Cap Screw, $\frac{1}{2}$ " long.
21	342X.124A	Stop Bracket Screw.	46	335X.139	Key for Upper Lever.
22	173/071H	$\frac{1}{16}$ " B.S.F. Hexagon Nut (Hardened).	47	572X.111A	Instruction Plate.
23	342X.123A	Stop Bracket Bush.	48	165/206	2 B.A. Round Head Set Screw, $\frac{3}{8}$ " long.
24	342X.143	Spacer.	49	327X.107	Gib Adjusting Screw.
25	101/15	1 $\frac{1}{2}$ " dia. External Circlip.	50	535X.113	Front Gib Strip.

List of Parts for
PLATE No. 28
(Drawing No. 335 Z 1)

WHEN ORDERING SPARE PARTS ALWAYS QUOTE THE SERIAL NUMBER OF THE MACHINE

UPPER CROSS SLIDES

2¼"-6, 2¼"-6D, 2"-6 AND 2"-6D BAR MACHINES

6⅝"-6, 6⅝"-6D CHUCKING MACHINES

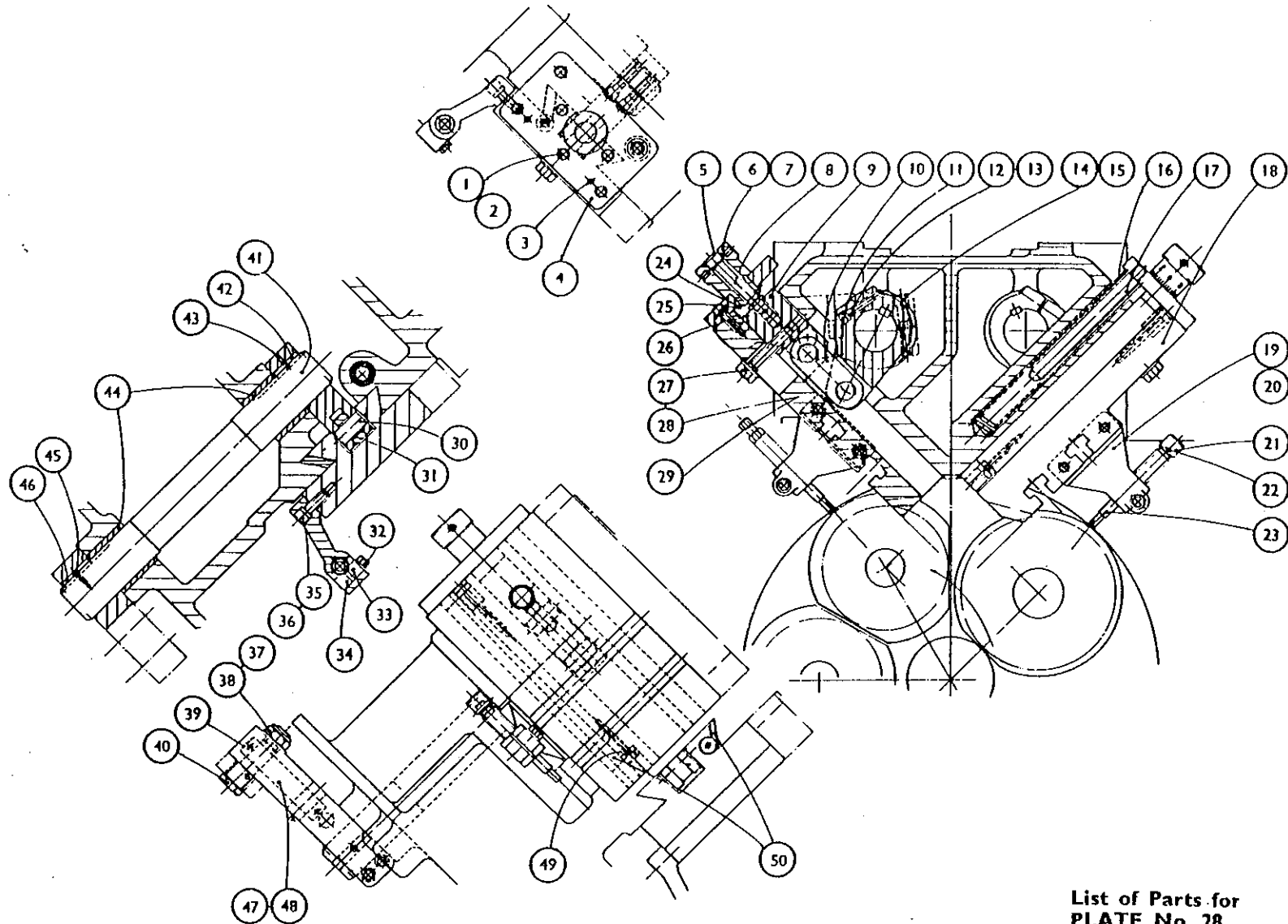

List of Parts for
PLATE No. 28
(Drawing No. 335 Z 1)

INDEX NO.	PART NO.	TITLE.	INDEX NO.	PART NO.	TITLE.
1	122/1632T	Key (Tapped), ¼" x ½" x 2" long.	24	337Z.151	Front Intermediate Slide Base.
2	337X.164	Pin for Operating Arm.	25	337X.163	Link.
3	236/121408	Oil Retaining Bush.	26	337X.160	Slide Bolt.
4	337X.155	Operating Lever.	27	337X.159	Adjusting Block.
5	154/10	½" Spring Washer.	28	125/1624	½" dia. Taper Pin, 1½" long.
6	155/1036	½" B.S.F. Socket Head Cap Screw, 2¼" long.	29	101/15	1½" dia. External Circlip.
7	337X.164	Pin for Operating Arm.	30	342X.143	Spacer.
8	337Y.153	Gib Strip.	31	129/13	1" dia. Welch Plug.
9	342V.112/E	Micrometer Head.	32	236/121412	Oil Retaining Bush.
10	342V.112/M	Micrometer Head.	33	122/1632T	Key (Tapped), ¼" x ½" x 2" long.
11	154/06	½" Spring Washer.	34	342X.139	Adjusting Screw.
12	155/0620	½" B.S.F. Socket Head Cap Screw, 1½" long.	35	337X.156	Operating Lever.
13	337X.154	End Bracket.	36	337X.113	Spring Support.
14	327X.107	Gib Adjusting Screw.	37	337X.118	Intermediate Slides Spring.
15	130/10	½" dia. Plain Washer.	38	141/3	½" dia. Taper Pin (Tapped), 1½" long.
16	173/10H	½" B.S.F. Hexagon Nut (Hardened).	39	210/1725	Yellow Indicator Washer.
17	225/3050	½" Copper Tube, ½" long.	40	212/04	½" B.S.F. Oil Nipple.
18	337Y.152	Intermediate Slide (Front).	41	176/0404	½" B.S.F. Socket Set Screw, ½" long.
19	159/208	2 B.A. Socket Countersunk Head Screw, ½" long.	42	154/10	½" Spring Washer.
20	337X.166	Chip Cover.	43	155/1028	½" B.S.F. Socket Head Cap Screw, 1½" long.
21	154/08	½" Spring Washer.	44	154/08	½" Spring Washer.
22	155/0828	½" B.S.F. Socket Head Cap Screw, 1½" long.	45	155/0828	½" B.S.F. Socket Head Cap Screw, 1½" long.
23	141/14	½" dia. Taper Pin (Tapped), 2" long.	46	337V.157	Operating Sleeve.

**List of Parts for
PLATE No. 29
(Drawing No. 337 Z I)**

WHEN ORDERING SPARE PARTS ALWAYS QUOTE THE SERIAL NUMBER OF THE MACHINE

FRONT INTERMEDIATE CROSS SLIDE
2 1/4"-6, 2 1/4"-6D, 2"-6 AND 2"-6D BAR MACHINES

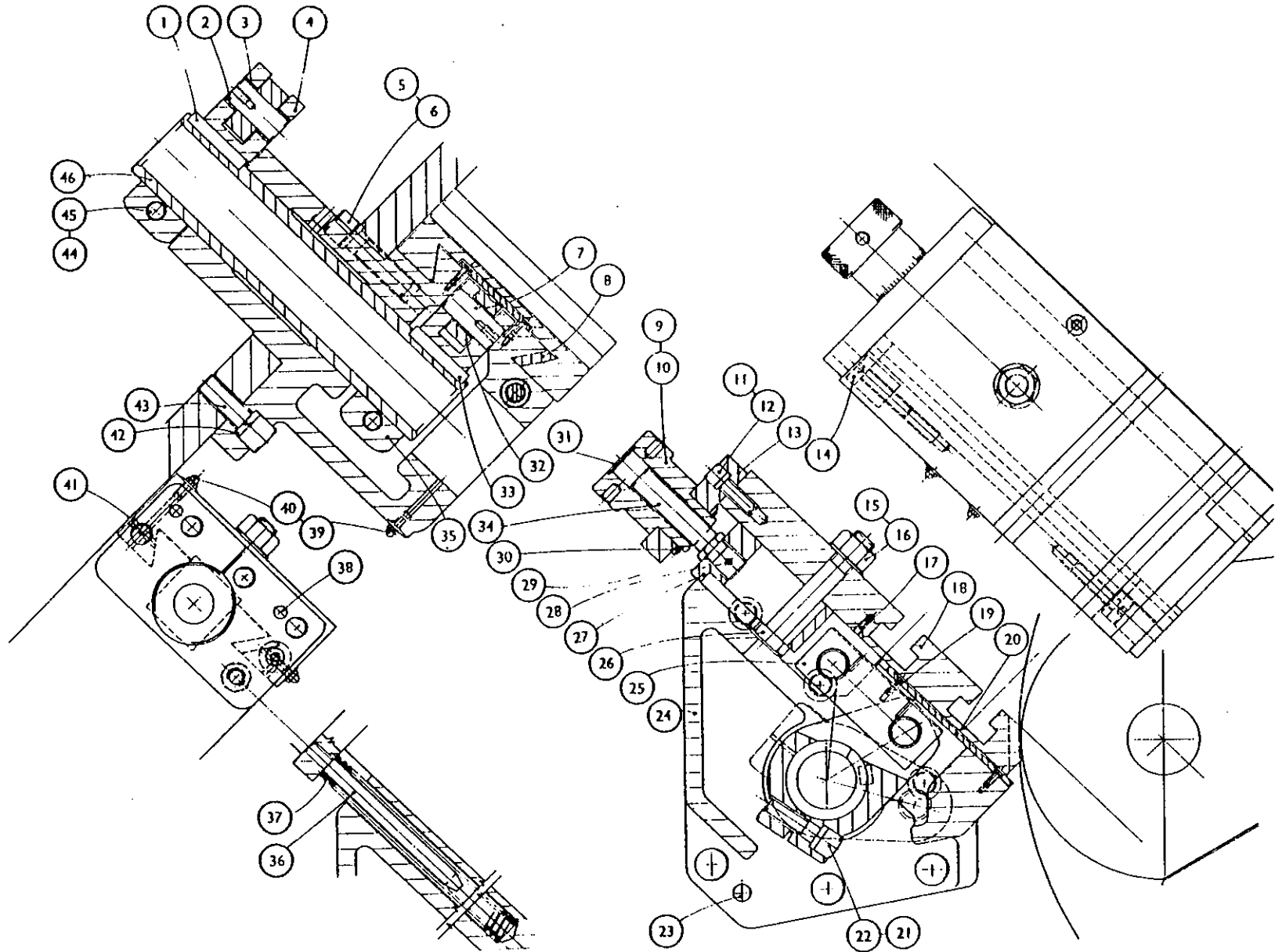

List of Parts for
PLATE No. 29
(Drawing No. 337 Z 1)

**WICKMAN
MULTI-SPINDLE
AUTOMATICS**

CROSS SLIDE OPERATION
2¼"-6, 2½"-6D, 2"-6 AND 2"-6D BAR MACHINES
6⅝"-6, 6⅞"-6D CHUCKING MACHINES

INDEX NO.	PART NO.	TITLE.	INDEX NO.	PART NO.	TITLE.
1	182/0624	¼" B.S.F. Socket Set Screw, Taper Point, 1¼" long.	12	182/0628	⅜" B.S.F. Socket Set Screw, Taper Point, 1¼" long.
2	203/06L	⅜" B.S.F. Self-Locking Nut (Thin).	13	203/06	⅜" B.S.F. Self-Locking Nut.
3	225/4050	¼" dia. Copper Tube, 1¼" long.	14	154/4	Spring Washer for 4 B.A.
4	203/06	⅜" B.S.F. Self-Locking Nut.	15	156/408	4 B.A. Socket Head Cap Screw, ½" long.
5	183/0628	⅜" B.S.F. Square Head Set Screw, Taper Point, 1¼" long.	16	341X.160	Indicator Finger.
6	182/0620	⅜" B.S.F. Socket Set Screw, Taper Point, 1¼" long.	17	541X.156	Spring Anchor.
7	203/06L	⅜" B.S.F. Self-Locking Nut (Thin).	18	341Z.101A	Front Cross Slide Cam Lever.
8	182/0624	¼" B.S.F. Socket Set Screw, Taper Point, 1¼" long.	19	341V.159A	Extension Spring.
9	203/06L	⅜" B.S.F. Self-Locking Nut (Thin).	20	341X.145A	Scale for Front Lower Cross Slide.
10	341Y.150	Oil Well.	21	159/406	4 B.A. Countersunk Head Cap Screw, ⅜" long.
11	155/0408	¼" B.S.F. Socket Head Cap Screw, ½" long.			

List of Parts for
PLATE No. 30
(Drawing No. 341 Z 1)

WHEN ORDERING SPARE PARTS ALWAYS QUOTE THE SERIAL NUMBER OF THE MACHINE

CROSS SLIDE OPERATION

2¼"-6, 2¼"-6D, 2"-6 AND 2"-6D BAR MACHINES

6⅝"-6, 6⅝"-6D CHUCKING MACHINES

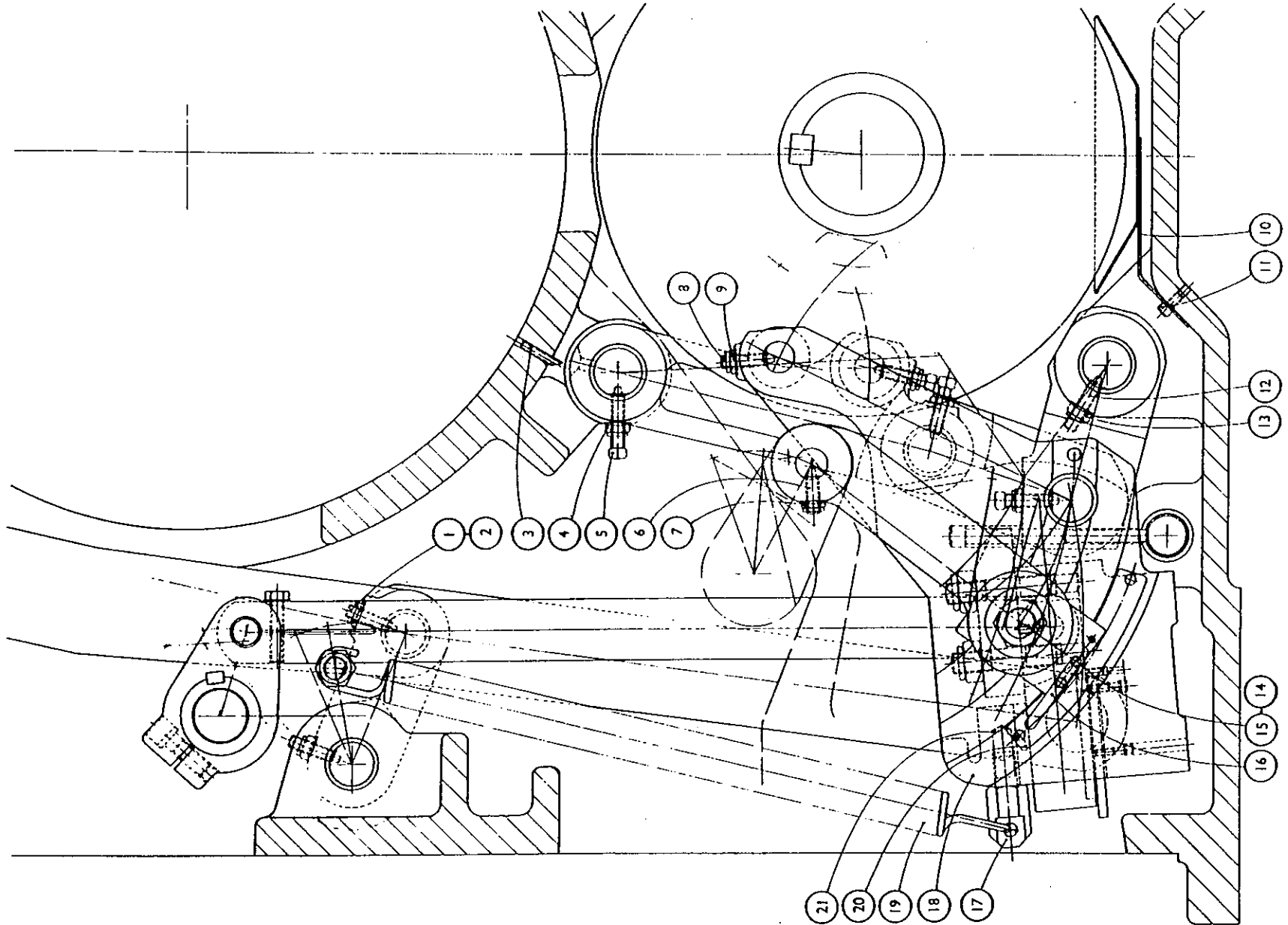

List of Parts for
PLATE No. 30
(Drawing No. 34I Z 1)

**WICKMAN
MULTI-SPINDLE
AUTOMATICS**

CROSS SLIDE OPERATION
2 $\frac{1}{4}$ "-6, 2 $\frac{1}{4}$ "-6D, 2"-6 AND 2"-6D BAR MACHINES
6 $\frac{5}{8}$ "-6, 6 $\frac{5}{8}$ "-6D CHUCKING MACHINES

INDEX NO.	PART NO.	TITLE.
1	167/0628	$\frac{3}{8}$ " B.S.F. Hexagon Head Set Screw, 1 $\frac{1}{2}$ " long.
2	198/13	$\frac{3}{8}$ " Shakeproof Lockwasher.
3	337X.105	Link.
4	341Z.102A	Rear Cross Slide Cam Lever.
5	541X.118	Indicator Pin.
6	337X.110	Carrier.
7	337X.120A	Scale.
8	156/214	2 B.A. Socket Head Cap Screw, $\frac{3}{4}$ " long.
9	154/03	$\frac{3}{16}$ " Spring Washer.

INDEX NO.	PART NO.	TITLE.
10	155/0408	$\frac{1}{4}$ " B.S.F. Socket Head Cap Screw, $\frac{1}{2}$ " long.
11	341Y.103	Approach Anchor Link.
12	341Y.105	Lower Approach Link.
13	203/06L	$\frac{3}{8}$ " B.S.F. Self-Locking Nut (Thin).
14	183/0624	$\frac{3}{8}$ " B.S.F. Square Head Set Screw, Taper Point, 1 $\frac{1}{2}$ " long.
15	341X.121	Distance Piece.
16	341X.120	Stop Screw.
17	341Y.104	Approach Arm.

List of Parts for
PLATE No. 31
(Drawing No. 341 Z 2)

WHEN ORDERING SPARE PARTS ALWAYS QUOTE THE SERIAL NUMBER OF THE MACHINE

CROSS SLIDE OPERATION
2 $\frac{1}{4}$ "-6, 2 $\frac{1}{4}$ "-6D, 2"-6 AND 2"-6D BAR MACHINES
6 $\frac{5}{8}$ "-6, 6 $\frac{5}{8}$ "-6D CHUCKING MACHINES

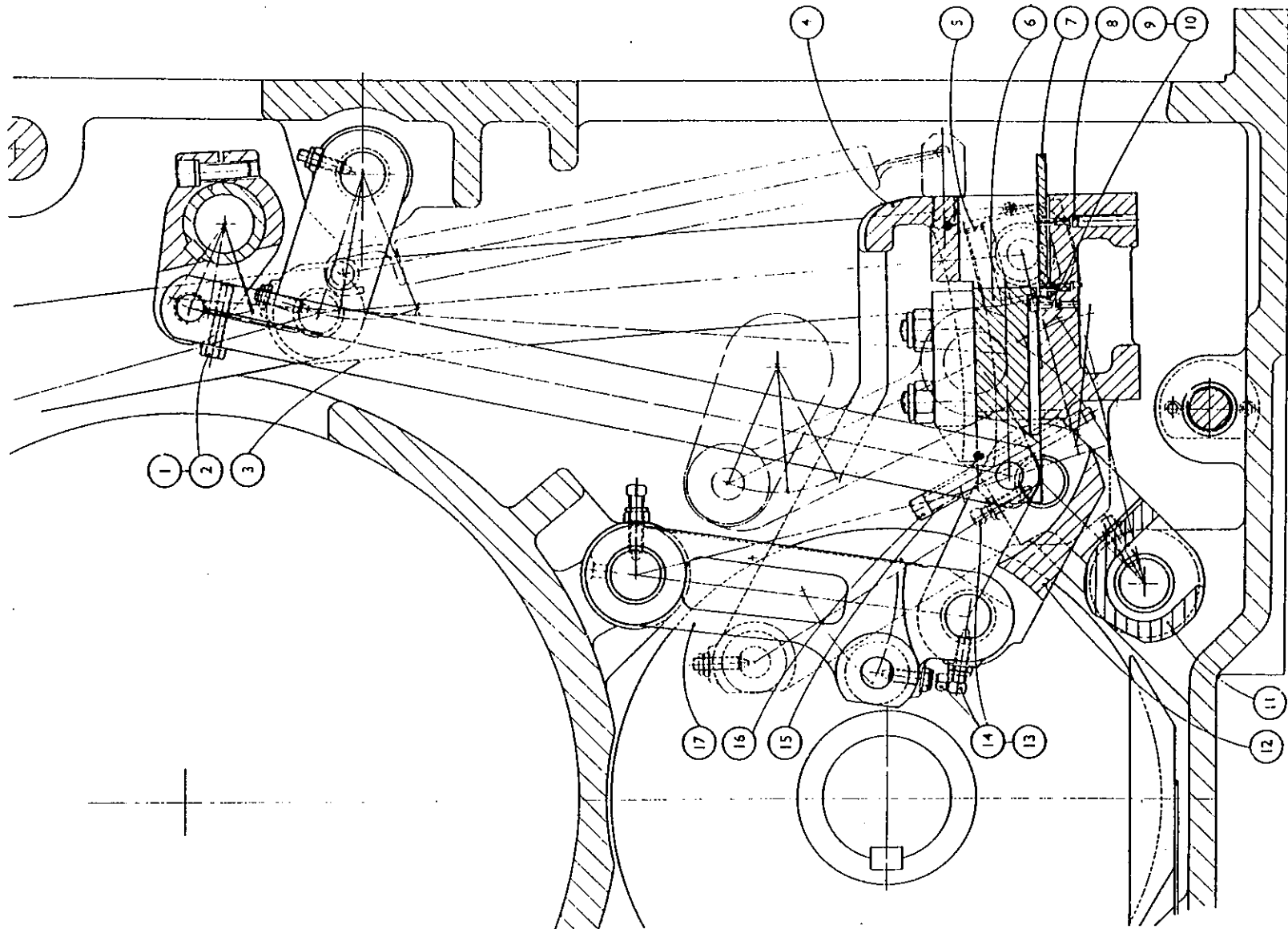

List of Parts for
PLATE No. 31
(Drawing No. 341 Z 2)

**WICKMAN
MULTI-SPINDLE
AUTOMATICS**

CROSS SLIDE OPERATION
2 $\frac{1}{4}$ "-6, 2 $\frac{1}{4}$ "-6D, 2"-6 AND 2"-6D BAR MACHINES
6 $\frac{5}{8}$ "-6, 6 $\frac{5}{8}$ "-6D CHUCKING MACHINES

INDEX NO.	PART NO.	TITLE.
1	341X.158	Spring Anchor.
2	341X.112	Connecting Pin.
3	341Y.106	Feed Link.
4	341X.130	Stop Shaft.
5	323X.174	Toggle Bush.
6	341X.129	Fulcrum Shaft.
7	341X.149A	Scale for Front Lower Cross Slide.
8	165/406	4 B.A. Round Head Screw, $\frac{3}{4}$ " long.
9	341X.108	Connecting Link.

INDEX NO.	PART NO.	TITLE.
10	236/182216	Oil Retaining Bush.
11	341X.126	Link Pin.
12	341X.140	Pivot Pin.
13	236/202416	Oil Retaining Bush.
14	341Y.109	Forked Intermediate Lever.
15	203/06	$\frac{3}{4}$ " B.S.F. Self-Locking Nut.
16	182/0624	$\frac{3}{4}$ " B.S.F. Socket Set Screw, Taper Point, 1 $\frac{1}{2}$ " long.
17	341Y.111	Link (To Upper Cross Slides).
18	236/182216	Oil Retaining Bush.

List of Parts for
PLATE No. 32
(Drawing No. 341 Z 3)

WHEN ORDERING SPARE PARTS ALWAYS QUOTE THE SERIAL NUMBER OF THE MACHINE

CROSS SLIDE OPERATION

2¼"-6, 2¼"-6D, 2"-6 AND 2"-6D BAR MACHINES

6⅝"-6, 6⅝"-6D CHUCKING MACHINES

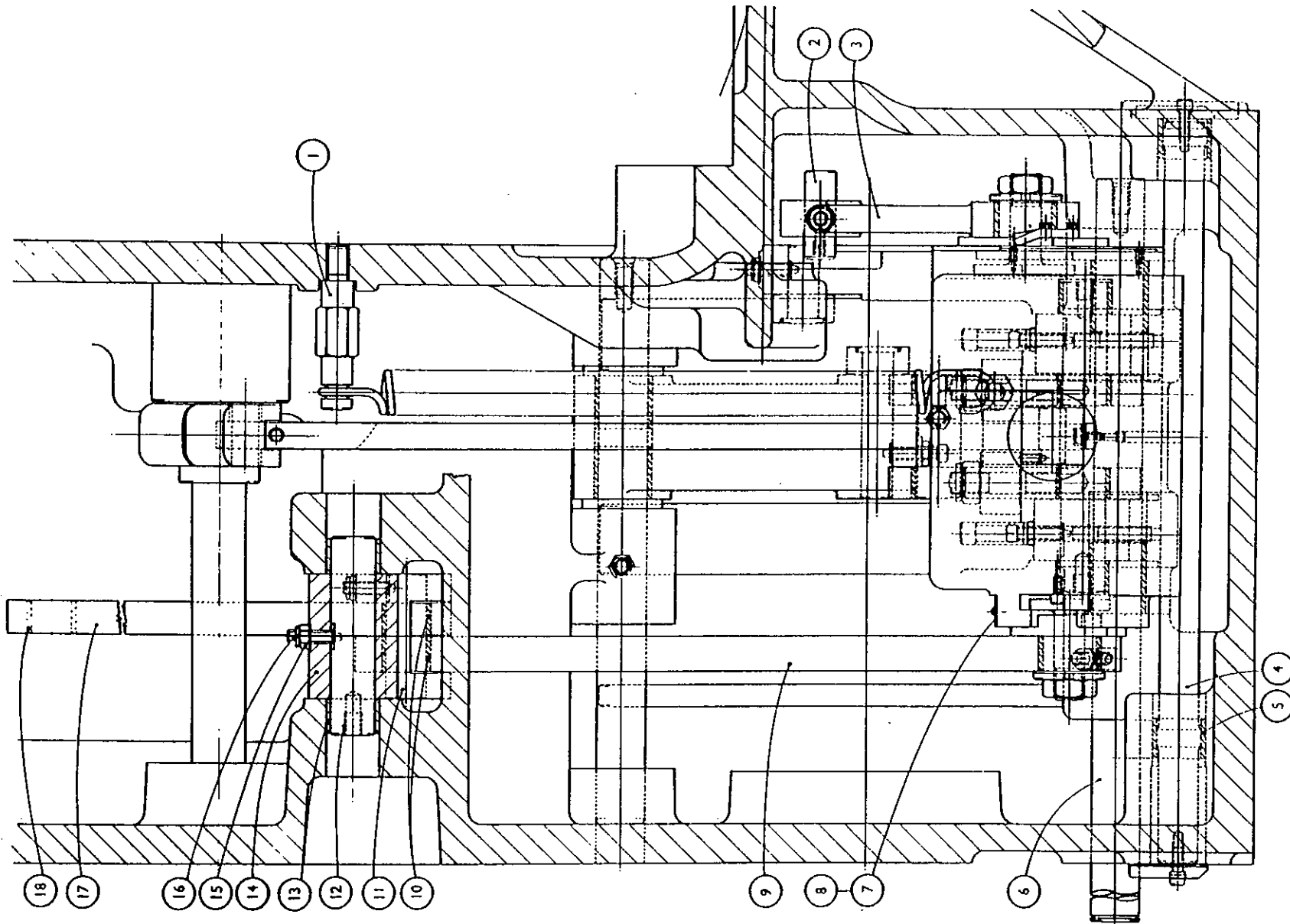

List of Parts for
PLATE No. 32
(Drawing No. 341 Z 3)

**WICKMAN
MULTI-SPINDLE
AUTOMATICS**

CROSS SLIDE OPERATION
2 $\frac{1}{4}$ "-6, 2 $\frac{1}{4}$ "-6D, 2"-6 AND 2"-6D BAR MACHINES
6 $\frac{5}{8}$ "-6, 6 $\frac{5}{8}$ "-6D CHUCKING MACHINES

INDEX NO.	PART NO.	TITLE.	INDEX NO.	PART NO.	TITLE.
1	341X.128	Fulcrum Shaft for Anchor Link.	17	341X.147A	Scale for Rear Upper Cross Slide.
2	236/222632	Oil Retaining Bush.	18	341X.160	Indicator Finger.
3	155/0408	$\frac{1}{4}$ " B.S.F. Socket Head Cap Screw, $\frac{3}{4}$ " long.	19	154/4	4 B.A. Spring Washer.
4	341X.132	Bush for Approach Link.	20	156/408	4 B.A. Socket Head Cap Screw, $\frac{1}{2}$ " long.
5	341X.127	Pivot Pin.	21	341X.119	Tee Bolt.
6	337X.107	Clamp Plate.	22	173/14HL	$\frac{3}{4}$ " B.S.F. Hexagon Locknut (Hardened).
7	337X.106	Clamp Plate.	23	341X.116	Slotted Washer.
8	236/222624	Oil Retaining Bush.	24	236/242816	Oil Retaining Bush.
9	341X.139	Fulcrum Shaft for Approach Lever.	25	341X.141A	Sliding Sleeve.
10	341X.133	Adjusting Washer.	26	341X.146A	Scale for Rear Lower Cross Slide.
11	341X.123	Feed Roller Pin.	27	159/406	4 B.A. Countersunk Head Screw, $\frac{3}{4}$ " long.
12	523X.135	Cam Roller.	28	341X.127	Pivot Pin.
13	341X.122	Approach Roller Pin.	29	341X.132	Bush for Approach Link.
14	203/10	$\frac{1}{2}$ " B.S.F. Self-Locking Nut.	30	182/0410	$\frac{1}{4}$ " B.S.F. Socket Set Screw, Taper Point, $\frac{1}{2}$ " long.
15	337X.119	Stud.	31	337X.108	Link Pin.
16	165/406	4 B.A. Round Head Screw, $\frac{3}{4}$ " long.			

List of Parts for
PLATE No. 33
(Drawing No. 341 Z 4)

WHEN ORDERING SPARE PARTS ALWAYS QUOTE THE SERIAL NUMBER OF THE MACHINE

CROSS SLIDE OPERATION

2¼"-6, 2¼"-6D, 2"-6 AND 2"-6D BAR MACHINES

6⅝"-6, 6⅝"-6D CHUCKING MACHINES

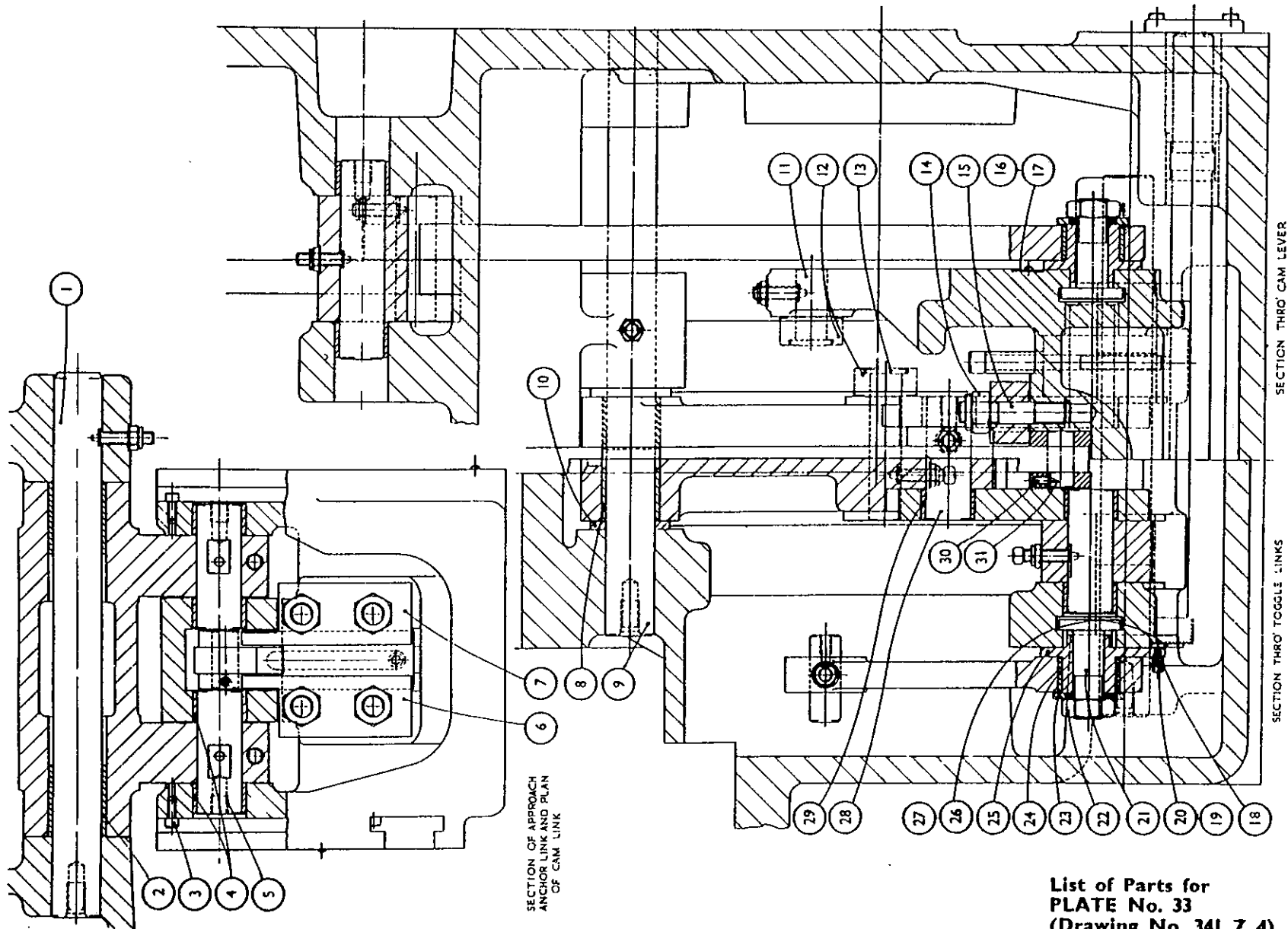

List of Parts for
PLATE No. 33
(Drawing No. 34I Z 4)

**WICKMAN
MULTI-SPINDLE
AUTOMATICS**

3RD STATION FORMING SLIDE

2¼"-6 AND 2"-6 BAR MACHINES

INDEX NO.	PART NO.	TITLE.	INDEX NO.	PART NO.	TITLE.
1	122/1632T	Key (Tapped), ¼" x ½" x 2" long.	31	337X.156	Operating Lever.
2	236/12140B	Oil Retaining Bush.	32	154/08	¼" Spring Washer.
3	337X.164	Pin for Operating Arm.	33	155/0828	¼" B.S.F. Socket Head Cap Screw, 1¼" long.
4	339Y.157	Operating Sleeve.	34	141/14	¼" dia. Tapped Taper Pin, 2" long.
5	154/10	¾" Spring Washer.	35	339Z.151	Rear Intermediate Forming Slide Base.
6	155/1036	¾" B.S.F. Socket Head Cap Screw, 2½" long.	36	337X.163	Link.
7	155/0828	¼" B.S.F. Socket Head Cap Screw, 1¼" long.	37	337X.159	Adjusting Block.
8	154/08	¼" Spring Washer.	38	337X.160	Slide Bolt.
9	342X.125	Threaded Locking Piece.	39	125/1624	¼" dia. Taper Pin, 1½" long.
10	342X.126	Plain Locking Piece.	40	101/15	1½" dia. External Circlip.
11	342X.122	Stop Bracket Lockbolt.	41	342X.143	Spacer.
12	342V.130B	Stop Bracket.	42	342X.139	Adjusting Screw.
13	159/208	2 B.A. Socket Head Screw, Countersunk, ½" long.	43	129/13	1" Welch Plug.
14	337X.166	Chip Cover.	44	339X.174	Plug for Slide Base.
15	236/121412	Oil Retaining Bush.	45	203/06	¾" B.S.F. Self-Locking Nut.
16	337X.164	Pin for Operating Arm.	46	182/0620	¾" B.S.F. Socket Set Screw, Taper Point, 1½" long.
17	339Y.153	Gib Strip for Rear Intermediate Slide.	47	141/3	½" dia. Tapped Taper Pin, 1½" long.
18	342V.112/E	Micrometer Head.	48	210/1725	Yellow Indicator Washer.
19	342V.112/M	Micrometer Head.	49	212/04	¼" B.S.F. Oil Nipple.
20	339X.154	Rear End Bracket.	50	337X.118	Intermediate Slides Spring.
21	155/0620	¾" B.S.F. Socket Head Cap Screw, 1½" long.	51	337X.113	Spring Support.
22	154/06	¾" Spring Washer.	52	176/0404	¼" B.S.F. Socket Set Screw, ¼" long.
23	130/10	¾" Flat Washer.	53	154/10	¾" Spring Washer.
24	173/10H	¾" B.S.F. Hexagon Nut.	54	155/1028	¾" B.S.F. Socket Head Cap Screw, 1½" long.
25	225/3050	¾" Copper Tube, ¾" long.	55	154/08	¼" Spring Washer.
26	327X.107	Gib Adjusting Screw.	56	155/0828	¼" B.S.F. Socket Head Cap Screw, 1¼" long.
27	342X.124A	Stop Bracket Screw.	57	337X.155	Operating Lever.
28	173/07H	¾" B.S.F. Hexagon Nut.	58	351X.138	Operating Shaft Bearing.
29	342X.123A	Stop Bracket Bush.	59	129/21	1½" dia. Welch Plug.
30	339Y.152	Rear Intermediate Slide.			

List of Parts for
PLATE No. 34
(Drawing No. 339 Z 1)

WHEN ORDERING SPARE PARTS ALWAYS QUOTE THE SERIAL NUMBER OF THE MACHINE

3RD STATION FORMING SLIDE
2 1/4"-6 AND 2"-6 BAR MACHINES

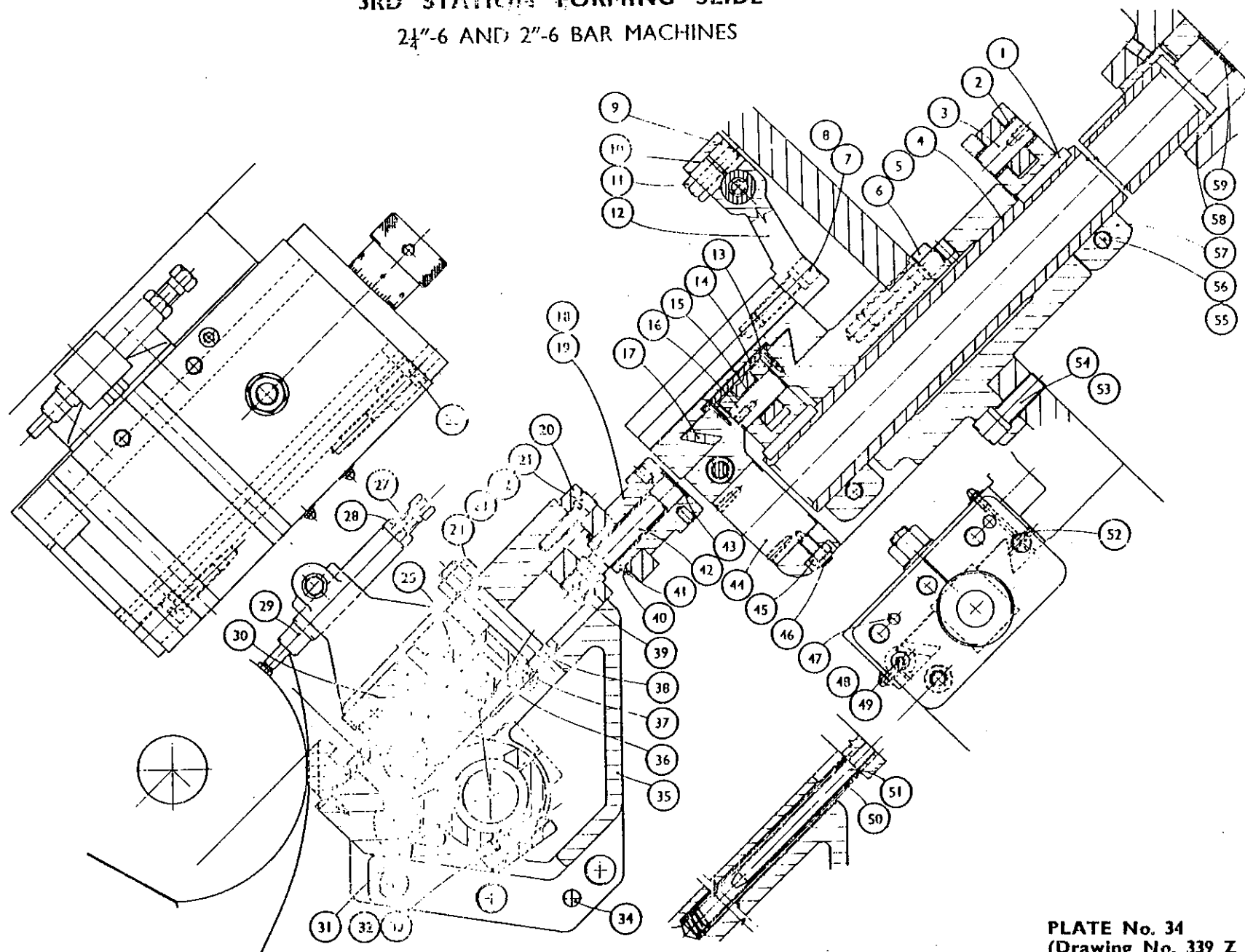

PLATE No. 34
(Drawing No. 339 Z 1)

**WICKMAN
MULTI-SPINDLE
AUTOMATICS**

**3RD STATION PART-OFF SLIDE
2¼"-6, 2¼"-6D, 2"-6 AND 2"-6D BAR MACHINES**

INDEX NO.	PART NO.	TITLE.	INDEX NO.	PART NO.	TITLE.
1	122/1632T	Key (Tapped), ½" x ¼" x 2" long.	28	342X.123A	Stop Bracket Bush.
2	337X.164	Pin for Operating Arm.	29	339Y.152	Rear Intermediate Slide.
3	236/121408	Oil Retaining Bush.	30	154/08	¼" Spring Washer.
4	337X.155	Operating Lever.	31	155/0828	½" B.S.F. Socket Head Cap Screw, 1½" long.
5	154/10	¼" Spring Washer.	32	141/14	½" dia. Tapped Taper Pin, 2" long.
6	155/1036	½" B.S.F. Socket Head Cap Screw, 2¼" long.	33	339Z.101	Rear Intermediate Cut-off Slide Base.
7	342X.125	Threaded Locking Piece.	34	337X.163	Link.
8	342X.126	Plain Locking Piece.	35	337X.160	Slide Bolt.
9	342X.122	Stop Bracket Lockbolt.	36	337X.159	Adjusting Block.
10	339V.116A	Stop Bracket.	37	125/1624	½" dia. Taper Pin, 1¼" long.
11	159/208	2 B.A. Socket Head Cap Screw, Countersunk, 1" long.	38	101/15	1¼" dia. External Circlip.
12	337X.166	Chip Cover.	39	342X.143	Spacer.
13	337X.164	Pin for Operating Arm.	40	342X.139	Adjusting Screw.
14	339Y.153	Gib Strip for Rear Intermediate Slide.	41	129/13	1" dia. Welch Plug.
15	342V.112/E	Micrometer Stop.	42	236/121412	Oil Retaining Bush.
16	342V.112/M	Micrometer Stop.	43	122/1632T	Key (Tapped), ½" x ¼" x 2" long.
17	154/06	¾" Spring Washer.	44	337X.156	Operating Lever.
18	155/0620	¾" B.S.F. Socket Head Cap Screw, 1¼" long.	45	212/04	½" B.S.F. Oil Nipple.
19	339X.154	Rear End Bracket.	46	210/1725	Yellow Indicator Washer.
20	225/3050	¾" Copper Tube, ¾" long.	47	141/3	½" dia. Tapped Taper Pin, 1¼" long.
21	130/10	¼" Flat Washer.	48	337X.113	Spring Support.
22	173/10H	½" B.S.F. Hexagon Nut.	49	337X.118	Intermediate Slides Spring.
23	327X.107	Gib Adjusting Screw.	50	176/0404	½" B.S.F. Socket Set Screw, ½" long.
24	342X.124A	Stop Bracket Screw.	51	154/10	¼" Spring Washer.
25	173/07H	¾" B.S.F. Hexagon Nut.	52	155/1028	½" B.S.F. Socket Head Cap Screw, 1½" long.
26	154/08	¼" Spring Washer.	53	154/08	¼" Spring Washer.
27	155/0820	½" B.S.F. Socket Head Cap Screw, 1¼" long.	54	155/0828	½" B.S.F. Socket Head Cap Screw, 1½" long.
			55	337V.157	Operating Sleeve.

List of Parts for
PLATE No. 35
(Drawing No. 339 Z 2)

WHEN ORDERING SPARE PARTS ALWAYS QUOTE THE SERIAL NUMBER OF THE MACHINE

3RD STATION PART-OFF SLIDE
2½"-6, 2¼"-6D, 2"-6 AND 2"-6D BAR MACHINES

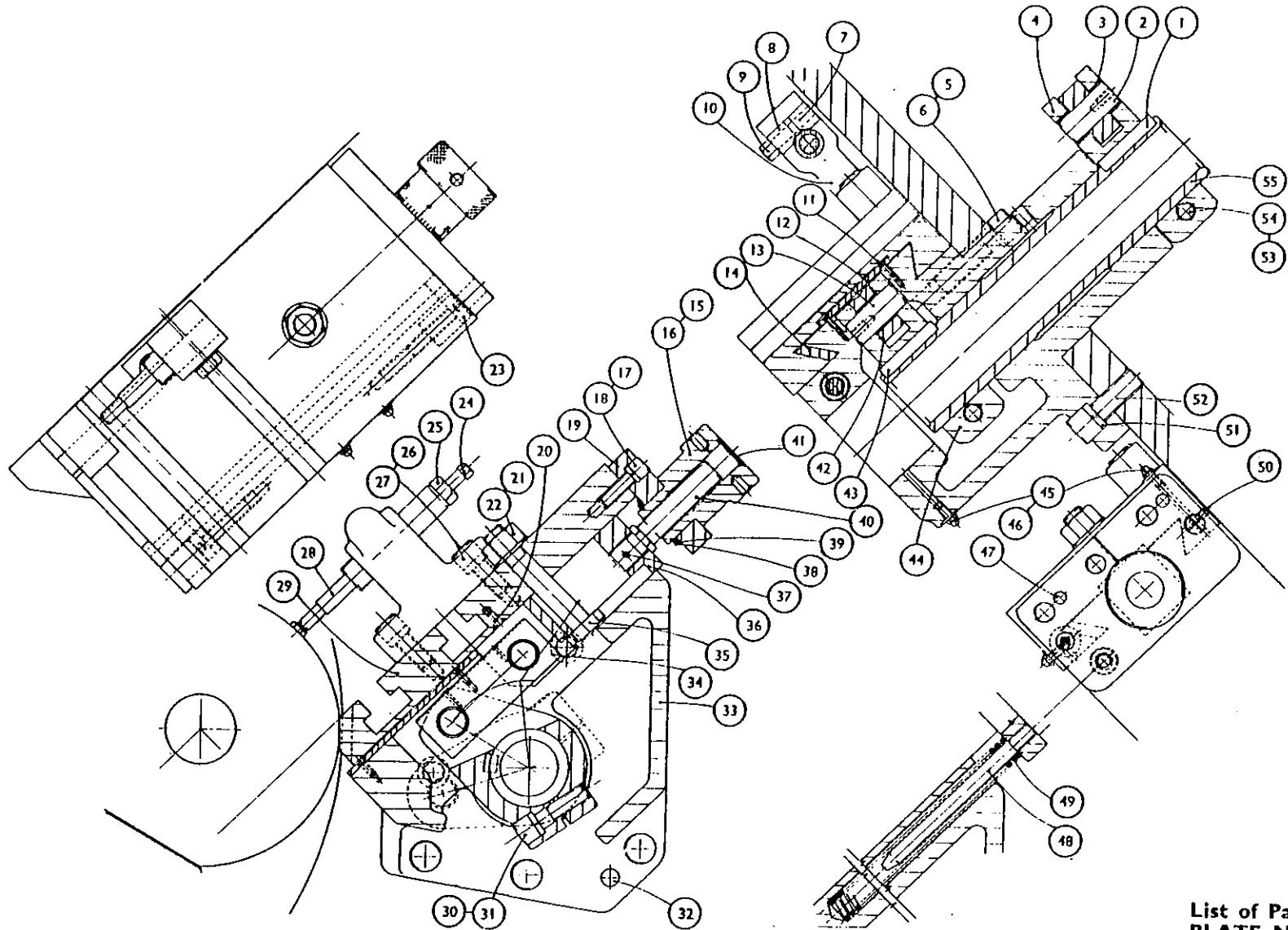

List of Parts for
PLATE No. 35
(Drawing No. 339 Z 2)

**WICKMAN
MULTI-SPINDLE
AUTOMATICS**

**3RD STATION CROSS SLIDE
6 $\frac{1}{8}$ "-6 AND 6 $\frac{1}{8}$ "-6D CHUCKING MACHINES**

INDEX NO.	PART NO.	TITLE.
1	342X.125	Threaded Locking Piece.
2	342X.126	Plain Locking Piece.
3	342X.122	Stop Bracket Lockbolt.
4	339V.113A	Stop Bracket.
5	155/0632	$\frac{3}{8}$ " B.S.F. Socket Head Cap Screw, 2" long.
6	141/14	$\frac{1}{4}$ " dia. Tapped Taper Pin, 2" long.
7	339Y.112	Packing Piece.
8	155/1060	$\frac{1}{2}$ " B.S.F. Socket Head Cap Screw, 3 $\frac{1}{2}$ " long.
9	154/10	$\frac{1}{2}$ " Spring Washer.
10	339Y.115	Operating Shaft.
11	154/10	$\frac{1}{2}$ " Spring Washer.
12	155/1068	$\frac{3}{8}$ " B.S.F. Socket Head Cap Screw, 4 $\frac{1}{2}$ " long.

List of Parts for
PLATE No. 36
(Drawing No. 339 Z 3)

WHEN ORDERING SPARE PARTS ALWAYS QUOTE THE SERIAL NUMBER OF THE MACHINE

3RD STATION CROSS SLIDE
6 $\frac{5}{8}$ "-6 6 $\frac{5}{8}$ "-6D CHUCKING MACHINES

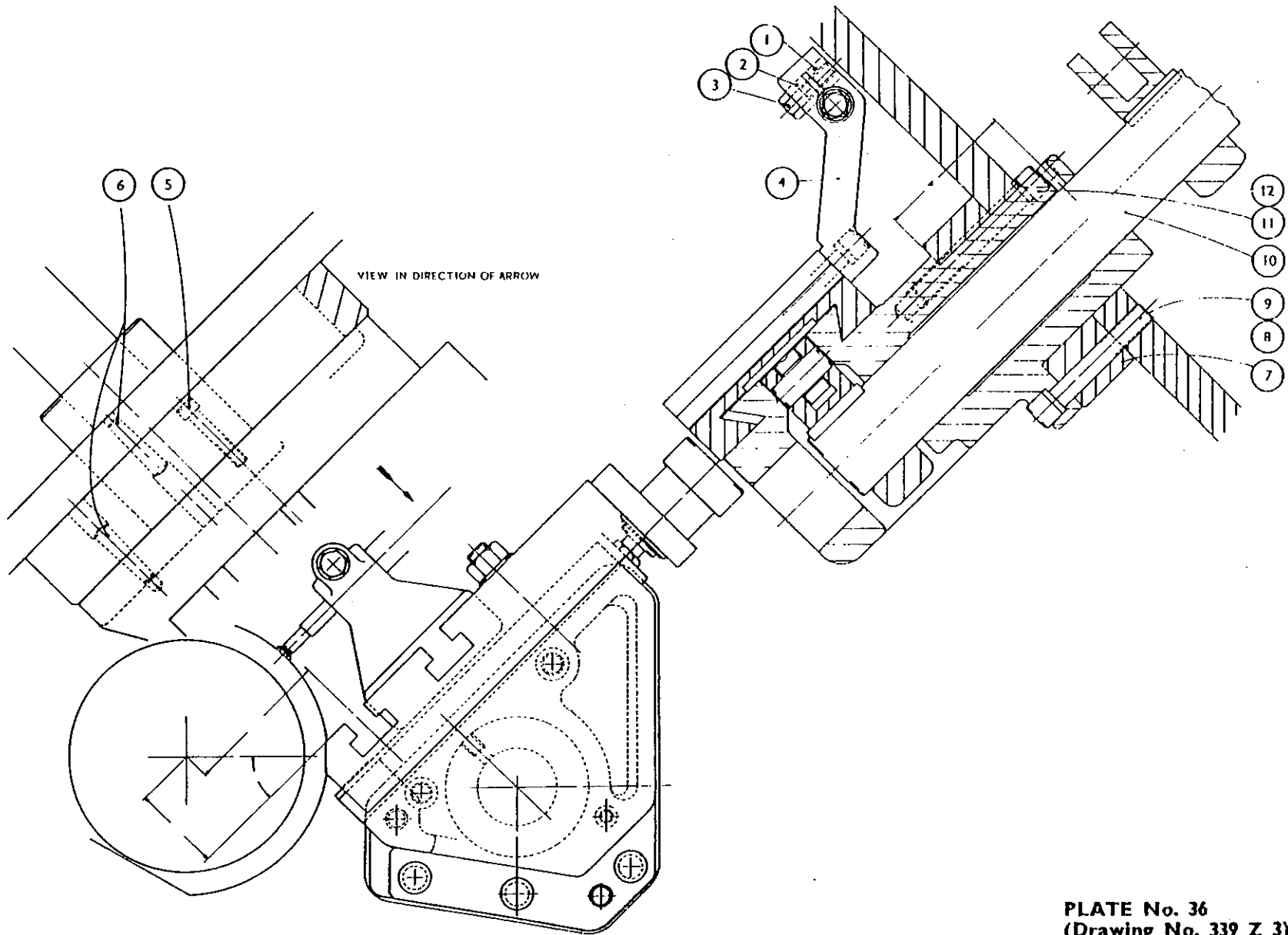

PLATE No. 36
(Drawing No. 339 Z 3)

**WICKMAN
MULTI-SPINDLE
AUTOMATICS**

LOWER CROSS SLIDES

2¼"-6, 2¼"-6D, 2"-6 AND 2"-6D BAR MACHINES

6⅝"-6, 6⅝"-6D CHUCKING MACHINES

INDEX NO.	PART NO.	TITLE.	INDEX NO.	PART NO.	TITLE.
1	183/0632	¼" B.S.F. Square Head Set Screw, Taper Point, 2" long.	29	542V.129	Flap.
2	203/06	¾" B.S.F. Self-Locking Nut.	30	342Z.108	Lower Rear Slide Base.
3	156/212	2 B.A. Socket Head Cap Screw, ¾" long.	31	141/17	¼" Extractable Taper Pin, 3" long.
4	154/03	¼" Spring Washer.	32	342Y.134	Rear Slide Feed Lever.
5	342Z.101A	Lower Cross Plate.	33	155/1044	¼" B.S.F. Socket Head Cap Screw, 2½" long.
6	342X.123A	Stop Bracket Bush.	34	154/10	¼" Spring Washer.
7	173/07H	¾" B.S.F. Hexagon Nut.	35	342V.112M	Micrometer Head.
8	342X.124A	Stop Bracket Screw.	36	342V.112E	Micrometer Head.
9	342X.142	Link.	37	327X.107	Gib Adjusting Screw.
10	342X.145	Slide Bolt.	38	535X.114	Rear Gib Strip.
11	130/10	¾" Flat Washer.	39	141/3	¼" Extractable Taper Pin, 3" long.
12	342V.141	Adjusting Block.	40	342X.135	Feed Lever Pivot Pin.
13	125/1624	½" dia. Taper Pin, 1½" long.	41	210/2525	Yellow Indicator Washer.
14	342X.138	End Bracket.	42	212/18	¼" B.S.P. Autolub Nipple.
15	129/13	1" dia. Welch Plug.	43	154/06	¼" Spring Washer.
16	342X.139	Adjusting Screw.	44	155/0616	¼" B.S.F. Socket Head Cap Screw, 1" long.
17	342X.143	Spacer.	45	335X.136	Link Pin.
18	101/15	1½" dia. External Circlip.	46	225/4050	¼" Copper Tube, ½" long.
19	342X.144	Nut.	47	236/141612	Oil Retaining Bush.
20	342Y.136	Front Slide Feed Lever.	48	342X.122	Stop Bracket Lockbolt.
21	342Z.107	Lower Front Slide Base.	49	342X.126	Plain Locking Piece.
22	155/1032	¾" B.S.F. Socket Head Cap Screw, 2" long.	50	342X.125	Threaded Locking Piece.
23	154/10	¼" Spring Washer.	51	342V.130B	Stop Bracket.
24	159/406	4 B.A. Countersunk Head Set Screw, ¾" long.	52	154/08	¼" Spring Washer.
25	342X.147	Wiper.	53	155/0824	¼" B.S.F. Socket Head Cap Screw, 1½" long.
26	342X.149	Front Plate for Slide Wiper.	54	194/1	¼" B.S.P. Socket Pipe Plug.
27	342X.146	Back Plate for Slide Wiper.	55	236/14808	Oil Retaining Bush.
28	162/210	2 B.A. Countersunk Head Screw, ¾" long.	56	236/141812	Oil Retaining Bush.
			57	236/222632	Oil Retaining Bush.

List of Parts for
PLATE No. 37
(Drawing No. 342 Z I)

WHEN ORDERING SPARE PARTS ALWAYS QUOTE THE SERIAL NUMBER OF THE MACHINE

LOWER CROSS SLIDES

2¼"-6, 2¼"-6D, 2"-6 AND 2"-6D BAR MACHINES

6⅝"-6 AND 6⅝"-6D CHUCKING MACHINES

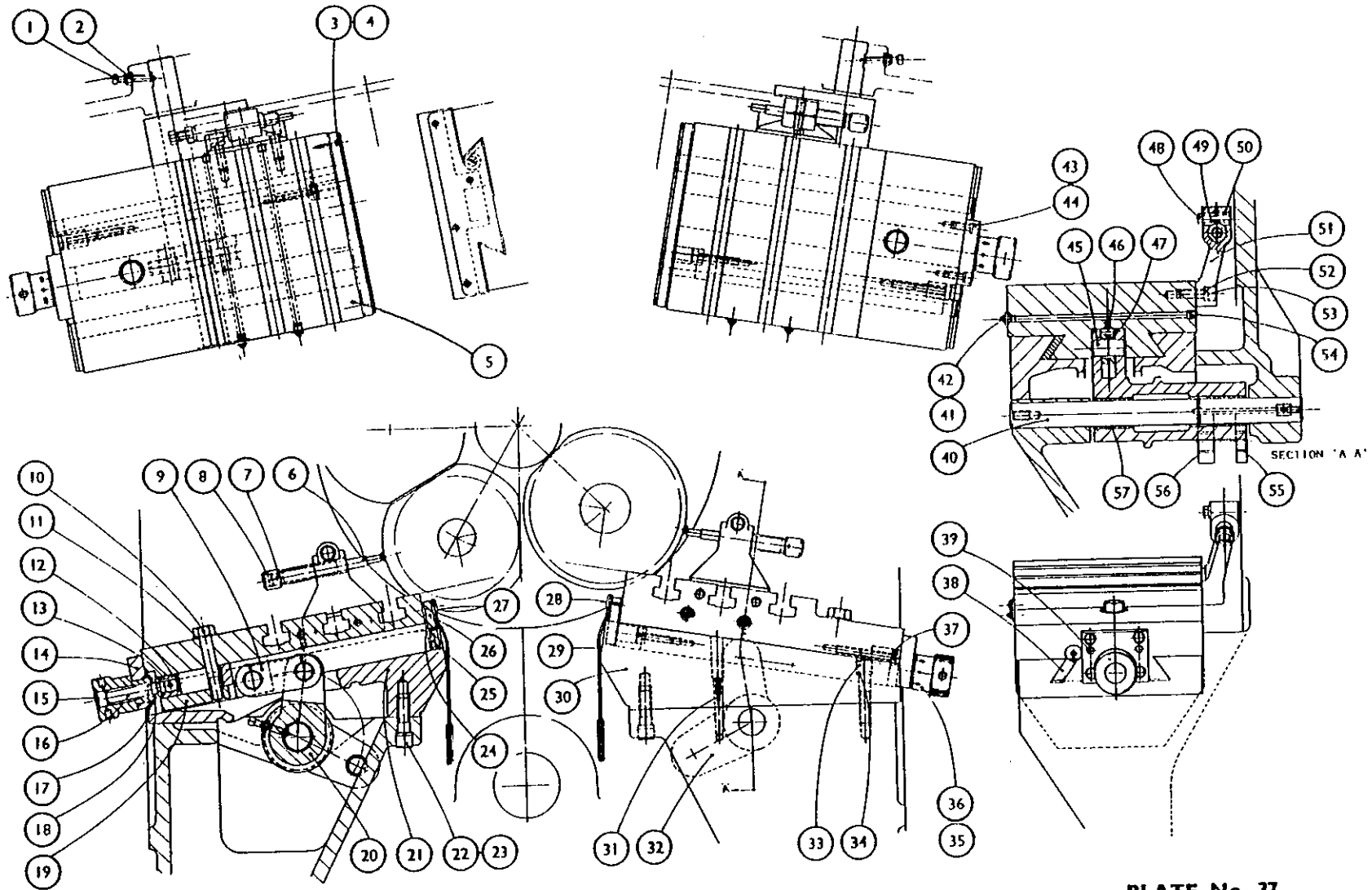

PLATE No. 37
(Drawing No. 342 Z 1)

**WICKMAN
MULTI-SPINDLE
AUTOMATICS**

CAMSHAFT

2½"-6, 2¼"-6D, 2"-6 AND 2"-6D BAR MACHINES

6⅝"-6, 6⅜"-6D CHUCKING MACHINES

INDEX NO.	PART NO.	TITLE.
1	155/0868	½" B.S.F. Socket Head Cap Screw, 4½" long. (2½"-6 and 2"-6 only).
2	154/08	½" Spring Washer (2½"-6 and 2"-6 only).
3	344V.156A	Camshaft Extension (2½"-6 and 2"-6 only).
4	154/06	½" Spring Washer.
5	155/0628	½" B.S.F. Socket Head Cap Screw, 1½" long.
6	263/60	Light Angular Contact Ball Journal, 60 x 110 x 22 mm.
7	344X.145A	Thrust Ring.
8	344X.147	Camshaft Key.
9	144X.129	Clutch Spring.
10	344Y.123A	Clutch Body.
11	3-4X.127	Thrust Ring.
12	154/04	½" Spring Washer.
13	155/0410	½" B.S.F. Socket Head Cap Screw, ½" long.
14	344X.144	Dowel.
15	344Y.122	Clutch Ring.
16	344Y.102B	Cam Drum (2½"-6 and 2"-6 only).
17	344Z.113A	Cam Drum (6⅝"-6 only).
18	359Y.102A	Cam Drum (2½"-6D and 2"-6D only).
19	210/2525	Yellow Indicator Washer.
20	212/18	½" B.S.P. Autolub Nipple.
21	141/20	½" Extractable Taper Dowel, 2½" long.
22	125/4080	½" dia. Taper Pin, 5" long.
23	544X.118	Collar.
24	344Y.125	Cam Carrier Bar Stop Cams (2½"-6 and 2"-6 only).
25	176/0406	½" B.S.F. Socket Set Screw, Cup Point, ½" long.
26	344V.134	Camshaft Bush.
27	344V.138	Camshaft Bearing Sleeve.
28	344Y.103A	Auxiliary Cam Disc.
29	544X.147	Key for Main Camshaft.
30	344Z.104	Rear Cross Slide Cam.
31	155/0812	½" B.S.F. Socket Head Cap Screw, ½" long.
32	154/08	½" Spring Washer.
33	344X.105	Front Cross Slide Cam.
34	544X.133	Key for Main Camshaft.
35	344V.137	Camshaft Bearing Sleeve.
36	344V.134	Camshaft Bush.
37	176/0406	½" B.S.F. Socket Set Screw, Cup Point, ½" long.
38	235/80967	Oil Seal.
39	344X.132	Camshaft Bearing.
40	344X.152	Thrust Washer.
41	155/1032	½" B.S.F. Socket Head Cap Screw, 2" long.

INDEX NO.	PART NO.	TITLE.
42	154/10	½" Spring Washer.
43	344X.148A	Camshaft Key.
44	344V.112/1	Cam Insert.
45	344V.112/2	Cam Insert.
46	155/0612	½" B.S.F. Socket Head Cap Screw, ½" long.
47	154/06	½" Spring Washer.
48	544X.136	Camshaft Spacer.
49	154/06	½" Spring Washer.
50	155/0624	½" B.S.F. Socket Head Cap Screw, 1½" long.
51	155/1032	½" B.S.F. Socket Head Cap Screw, 2" long.
52	154/10	½" Spring Washer.
53	344Z.101.	Main Camshaft.
54	154/10	½" Spring Washer.
55	155/1032	½" B.S.F. Socket Head Cap Screw, 2" long.
56	194/1	½" B.S.P. Socket Pipe Plug.
57	155/0620	½" B.S.F. Socket Head Cap Screw, 1½" long.
58	154/06	½" Spring Washer.
59	345X.125	Detent.
60	212/04	½" B.S.F. Oil Nipple.
61	144X.146	Spring Support.
62	544Y.121B	End Bearing Housing.
63	544V.150	End Cover.
64	155/0828	½" B.S.F. Socket Head Cap Screw, 1½" long.
65	154/08	½" Spring Washer.
66	212/9018	½" B.S.P. Autolub Nipple.
67	210/2525	Yellow Indicator Washer.
68	544X.152	Coupling Pin.
69	155/08128	½" B.S.F. Socket Head Cap Screw, 8" long (6⅝"-6 only).
70	154/08	½" Spring Washer (6⅝"-6 only).
71	544V.151	Camshaft Extension (6⅝"-6 only).
72	522V.209	Camshaft Cover.
73	154/05	½" Spring Washer.
74	155/0532	½" B.S.F. Socket Head Cap Screw, 2" long.
75	176/0406	½" B.S.F. Socket Set Screw, Cup Point, ½" long.
76	344Y.150	Bearing Plate.
77	155/0828	½" B.S.F. Socket Head Cap Screw, 1½" long.
78	154/08	½" Spring Washer.
79	344X.151	Camshaft Bearing.
80	344Y.130A	Cam Drum.
81	344Y.131	Worm Wheel Hub.
82	141/20	½" Extractable Taper Dowel, 2½" long.
83	318Y.124	Lower Worm Wheel.

List of Parts for
PLATE No. 38
(Drawing No. 344 Z I)

WHEN ORDERING SPARE PARTS ALWAYS QUOTE THE SERIAL NUMBER OF THE MACHINE

CAMSHAFT

2¼"-6, 2¼"-6D, 2"-6 AND 2"-6D BAR MACHINES

6⅝"-6, 6⅝"-6D CHUCKING MACHINES

Last Used On
Machine No.13916

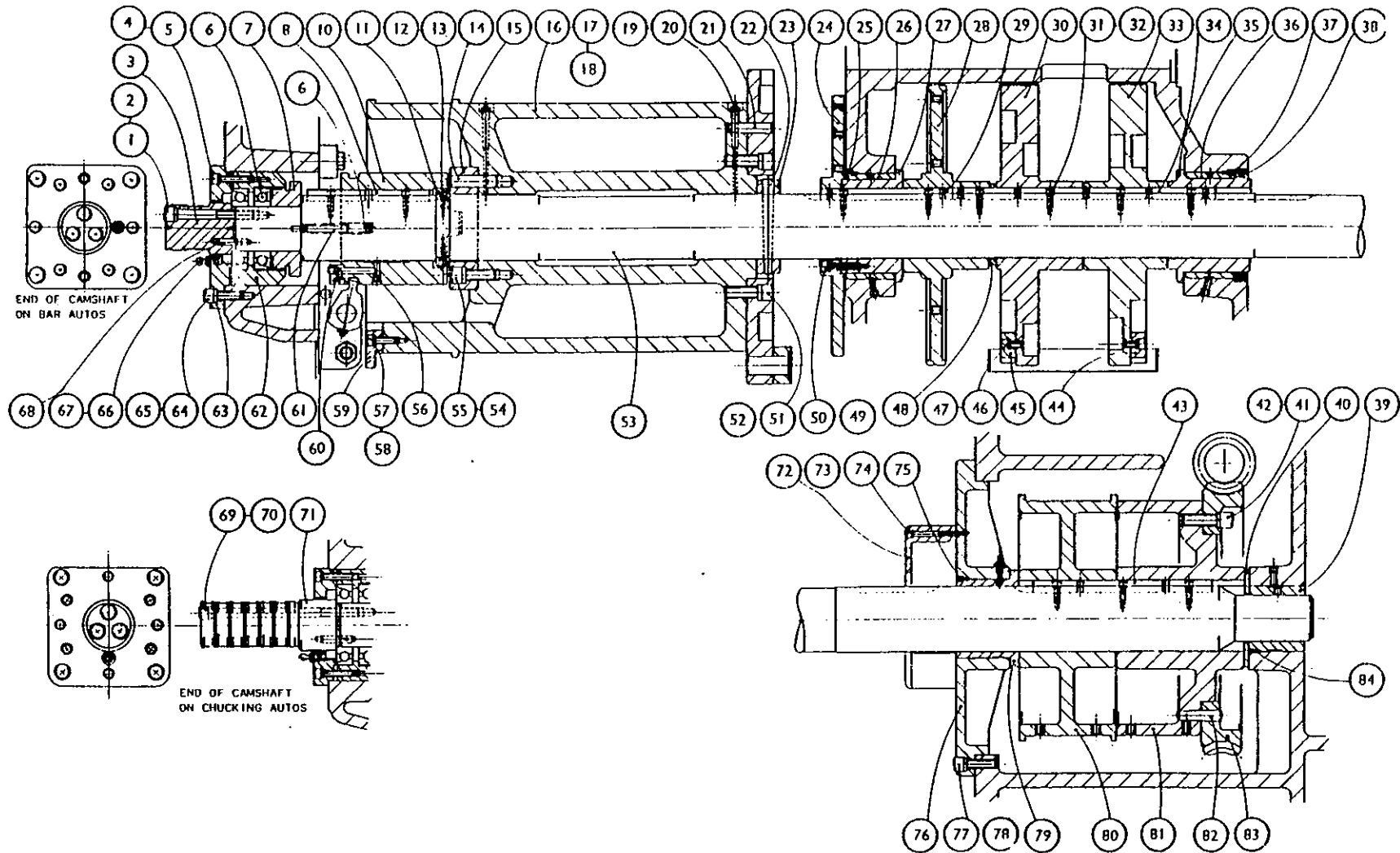

PLATE No. 38
(Drawing No. 344 Z 1)

**WICKMAN
MULTI-SPINDLE
AUTOMATIC**

344 Z 1B MAIN CAMSHAFT
2"-6, 6 $\frac{3}{8}$ "-6 MACHINES. SECTIONS 344, 344H

Commencing on
M/c No.13917
(Also Used on
M/c No.13910)

INDEX NO.	PART NO.	TITLE	INDEX NO.	PART NO.	TITLE
1	155/0872	Socket Head Cap Screw, $\frac{1}{2}$ " B.S.F. x $4\frac{1}{2}$ " long)	36	344V.134	Camshaft Bush
2	154/08	Spring Washer, for $\frac{1}{2}$ " dia.) 2"-6, 2 $\frac{3}{4}$ "-4	37	155/0518	Socket Head Cap Screw, 5/16" B.S.F. x 1" long
3	344V.156A	Camshaft Extension)	38	344V.153	Camshaft Housing
4	154/08	Spring Washer, for 3/16" dia.	39	154/05	Spring Washer, for 5/16" dia.
5	155/0628	Socket Head Cap Screw, $\frac{3}{8}$ " B.S.F. x $1\frac{1}{2}$ " long	40	244X.156	Piston Ring
6	263/60	Ball Journal, Angular Contact, Light Metric, 60mm	41	344X.154	Ring Housing
7	344X.145B	Thrust Ring	42	354/44	" O " Ring for $3\frac{1}{2}$ " dia.
8	344X.147B	Camshaft Key	43	344V.155	End Cap
9	244X.129A	Clutch Spring	44	154/04	Spring Washer, for $\frac{1}{2}$ " dia.
10	344Y.123B	Clutch Body	45	155/0412	Socket Head Cap Screw, $\frac{1}{2}$ " B.S.F. x $\frac{1}{2}$ " long
11	344X.127	Thrust Ring	46	176/0406	Socket Set Screw, $\frac{1}{4}$ " B.S.F. x $\frac{3}{8}$ " long
12	154/04	Spring Washer, for $\frac{1}{4}$ " dia.	47	154/10	Spring Washer, for $\frac{5}{8}$ " dia.
13	155/0410	Socket Head Cap Screw, $\frac{3}{4}$ " B.S.F. x $\frac{5}{8}$ " long	48	155/1032	Socket Head Cap Screw, $\frac{5}{8}$ " B.S.F. x 2" long
14	344X.144	Dowel	49	155/0624	Socket Head Cap Screw, $\frac{3}{8}$ " B.S.F. x $1\frac{1}{2}$ " long
15	344Y.122	Clutch Ring	50	154/06	Spring Washer, for $\frac{3}{4}$ " dia.
16	344Y.102B	Cam Drum (2"-6, 2 $\frac{5}{8}$ "-4)	51	522V.209	Camshaft Cover
17	344Z.113A	Cam Drum (6 $\frac{3}{8}$ "-6, 8"-4)	52	154/05	Spring Washer, for 5/16" dia.
18	359Y.102A	Cam Drum (2"-6D)	53	155/0532	Socket Head Cap Screw, 5/16" dia. x 2" long
19	210/2525	Yellow Washer, for $\frac{1}{8}$ " B.S.P.	54	176/0406	Socket Set Screw, $\frac{1}{4}$ " B.S.F. x $\frac{1}{8}$ " long
20	212/18	Nipple, $\frac{1}{8}$ " B.S.P.	55	544X.136	Camshaft Spacer
21	141/20	Taper Pin, $\frac{5}{8}$ " dia. x 2 $\frac{1}{2}$ " long	56	154/06	Spring Washer, for $\frac{3}{8}$ " dia.
22	125/4080	Taper Pin, $\frac{3}{8}$ " dia. x 5" long	57	155/0612	Socket Head Cap Screw, $\frac{3}{8}$ " B.S.F. x $\frac{1}{2}$ " long
23	544X.118	Collar	58	344V.112/2	Cam Insert
24	344Y.125	Cam Carrier Bar Stop Cams (2"-6, 2 $\frac{5}{8}$ "-4 only)	59	344V.112/1	Cam Insert
25	176/0406	Socket Set Screw, $\frac{1}{4}$ " B.S.F. x $\frac{3}{8}$ " long	60	154/10	Spring Washer, for $\frac{5}{8}$ " dia.
26	344V.134	Camshaft Bush	61	155/1032	Socket Head Cap Screw, $\frac{5}{8}$ " B.S.F. x 2" long
27	344V.138	Camshaft Bearing Sleeve	62	344X.152	Thrust Washer
28	344Y.103A	Auxiliary Cam Disc	63	344X.132	Camshaft Bearing
29	544X.147A	Key for Main Camshaft	64	176/0406	Socket Set Screw, $\frac{1}{4}$ " B.S.F. x $\frac{3}{8}$ " long
30	344Z.104	Rear Cross-Slide Cam	65	318Y.124	Lower Wormwheel
31	155/0616	Socket Head Cap Screw, $\frac{3}{8}$ " B.S.F. x 1" long	66	141/20	Taper Pin, Tapped, $\frac{5}{8}$ " dia. x 2 $\frac{1}{2}$ " long
32	154/06	Spring Washer, for 3/16" dia.	67	-	This arrangement of cam drum and wormwheel used only up to Machine No. 11638
33	344Z.105	Front Cross-Slide Cam	68	344X.151	Camshaft Bearing
34	544X.133A	Key for Main Camshaft	69	154/08	Spring Washer, for $\frac{1}{2}$ " dia.
35	344Y.137	Camshaft Bearing Sleeve			

List of Parts for
Plate No. 38A
(Drawing No. 344 Z 1B)

WHEN ORDERING SPARE PARTS ALWAYS QUOTE THE INSPECTION NUMBER OF THE MACHINE

**WICKMAN
MULTI-SPINDLE
AUTOMATIC**

344 Z 1B MAIN CAMSHAFT
2"-6, 6 $\frac{1}{8}$ "-6 MACHINES. SECTIONS 344, 344H

Commencing on
M/c No.13917
(Also Used on
M/c No.13910)

INDEX NO.	PART NO.	TITLE
70	155/0828	Socket Head Cap Screw, $\frac{1}{2}$ " B.S.F. x $1\frac{1}{4}$ " long
71	344Y.150	Bearing Plate
72	-	Arrangement of cam and wormwheel hub used on machines after No. 11628
73	344Y.140	Cam Drum Assembly
74	-	For end of camshaft on chucks see 315 Z5. This extension only required as a special order on bar machines.
75	544Y.151A	Camshaft Extension)
76	154/08	Spring Washer, for $\frac{1}{2}$ " dia.) 8"-4, 6 $\frac{1}{8}$ "-6
77	155/08136	Socket Head Cap Screw, $\frac{1}{2}$ " B.S.F. x $8\frac{1}{2}$ " long)
78	210/2526	Yellow Washer, for $\frac{3}{8}$ " B.S.P.)
79	544X.152	Coupling Pin
80	212/9018	Nipple, $\frac{1}{4}$ " B.S.P.
81	154/08	Spring Washer, for $\frac{1}{2}$ " dia.
82	155/0828	Socket Head Cap Screw, $\frac{1}{2}$ " B.S.F. x $1\frac{1}{4}$ " long
83	544V.150A	End Cover
84	544Y.121C	End Bearing Housing
85	244X.146	Spring Support
86	212/04	Oil Nipple, $\frac{1}{4}$ " B.S.F.
87	345X.125	Detent
88	155/0620	Socket Head Cap Screw, $\frac{3}{8}$ " B.S.F. x $1\frac{1}{4}$ " long
89	154/06	Spring Washer, for $\frac{3}{8}$ " long
90	194/1	Plug, $\frac{1}{4}$ " B.S.P.
91	155/1032	Socket Head Cap Screw, $\frac{3}{8}$ " B.S.F. x 2" long
92	154/10	Spring Washer, for $\frac{3}{8}$ " dia.
93	344X.148B	Camshaft Key
94	155/0616	Socket Head Cap Screw, $\frac{3}{8}$ " B.S.F. x 1" long
95	154/06	Spring Washer, for $\frac{3}{8}$ " dia.
96	344Z.101B	Main Camshaft

List of Parts for
Plate No. 38A
(Drawing No. 344 Z 1B)

WHEN ORDERING SPARE PARTS ALWAYS QUOTE THE INSPECTION NUMBER OF THE MACHINE

MAIN CAMSHAFT

2 1/4"-6, 2 1/4"-6D, 2"-6 AND 2"-6D BAR MACHINES

6 1/4"-6, 6 1/4"-6D CHUCKING MACHINES

Constructing
Machine No.13917
(Also Used Machine 13910)

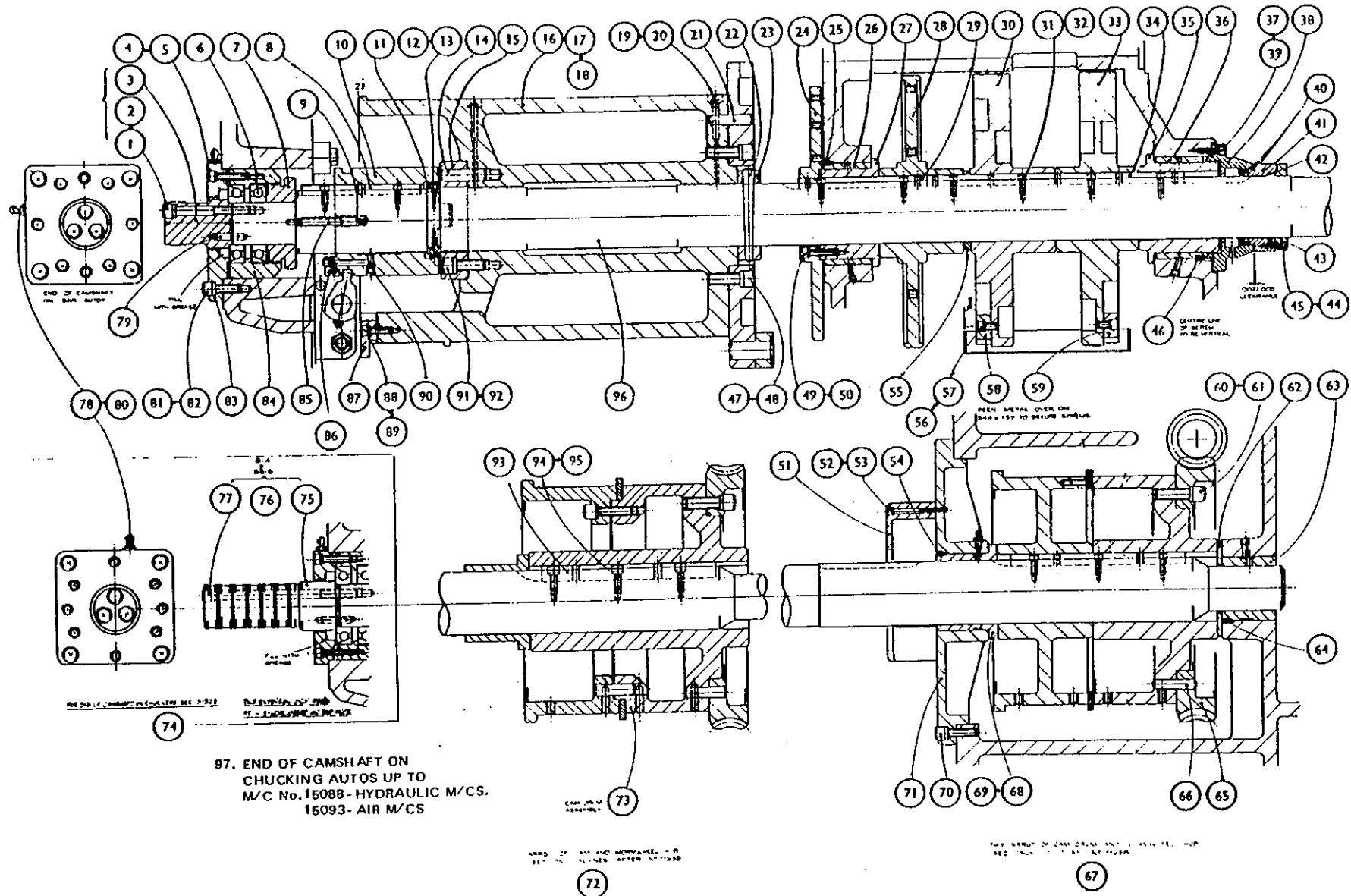

**WICKMAN
MULTI-SPINDLE
AUTOMATICS**

INDEX CLUTCH OPERATION
2¼"-6, 2¼"-6D, 2"-6 AND 2"-6D BAR MACHINES
6⅝"-6, AND 6⅝"-6D CHUCKING MACHINES

INDEX NO.	PART NO.	TITLE.	INDEX NO.	PART NO.	TITLE.
1	125/1116	½" dia. Taper Pin, 1" long.	29	130/08	½" Flat Washer.
2	345X.108	Pawl.	30	173/10	½" B.S.F. Hexagon Nut.
3	345X.129	Spring Sleeve.	31	173/10L	½" B.S.F. Hexagon Locknut.
4	345X.110	Spring.	32	203/05	⅝" B.S.F. Self-Locking Nut.
5	154/06	½" Spring Washer.	33	182/0516	⅝" B.S.F. Socket Set Screw, Taper Point, 1" long.
6	155/0624	½" B.S.F. Socket Head Cap Screw, 1½" long.	34	121/0828T	½" Square Tapped Key, 1½" long.
7	356X.137	Handle.	35	173/10L	½" B.S.F. Hexagon Locknut.
8	345X.106	Lever Boss.	36	182/0516	⅝" B.S.F. Socket Head Cap Screw, Taper Point, 1" long.
9	176/0012	½" B.S.F. Socket Set Screw, ½" long.	37	203/05	⅝" B.S.F. Self-Locking Nut.
10	126/1218	½" dia. Parallel Pin, 1½" long.	38	599AX.108	Pusher Connection.
11	212/4518	½" B.S.P. Autolub Nipple, 45° angled.	39	345Y.120	Lever.
12	210/2525	Yellow Indicator Washer.	40	345X.104A	Shaft.
13	182/0516	⅝" B.S.F. Socket Set Screw, Taper Point, 1" long.	41	154/06	½" Spring Washer.
14	203/05	⅝" B.S.F. Self-Locking Nut.	42	155/0644	½" B.S.F. Socket Head Cap Screw, 2½" long.
15	155/0610	½" B.S.F. Socket Head Cap Screw, ½" long.	43	345X.105	Clutch Rod Bracket.
16	154/06	½" Spring Washer.	44	121/0824T	½" Square Tapped Key, 1½" long.
17	545X.111	Baulking Strip.	45	241/8	1½" dia. Black Bakelite Knob.
18	545X.112	Fulcrum Stud.	46	345X.109	Lever.
19	345V.101B	Clutch Lever.	47	101/15	1½" dia. External Circlip.
20	155/0624	½" B.S.F. Socket Head Cap Screw, 1½" long.	48	236/202424	Oil Retaining Bush.
21	154/06	½" Spring Washer.	49	179/203	2 B.A. Socket Set Screw, ⅝" long.
22	345X.128	Shaft.	50	345X.123	Pivot Shaft (2¼"-6 only)
23	345X.122	Spring Rod.		245X.123	Pivot Shaft (6⅝"-6 only)
24	173/08L	½" B.S.F. Hexagon Locknut.	51	203/08	½" B.S.F. Self-Locking Nut
25	173/08	½" B.S.F. Hexagon Nut.	52	182/0828	½" B.S.F. Socket Set Screw, Taper Point, 1½" long
26	130/08	½" Flat Washer.	53	236/121414	Oil Retaining Bush
27	345V.102	Clutch Lever Bracket.	54	141X.122	Pin for Cam Roller
28	345X.127	Spring.	55	141X.121	Cam Roller

List of Parts for
PLATE No. 39
(Drawing No. 345 Z I)

WHEN ORDERING SPARE PARTS ALWAYS QUOTE THE SERIAL NUMBER OF THE MACHINE

315 Z 1 HYDRAULIC CONTROL ARRANGEMENT FRONT VIEW

Last used on
Inspection No.15783

6 $\frac{1}{8}$ "-6H MACHINES. SECTION 315

INDEX NO.	PART NO.	TITLE
1	215Z.110A	End Bracket 5 $\frac{1}{8}$ "-6H
2	315Z.110A	End Bracket 6 $\frac{1}{8}$ "-6H
3	155/0648	$\frac{3}{4}$ " BSF Socket Head Cap Screw 3" long
4	154/06	$\frac{3}{4}$ " Spring Washer
5	155/1032	$\frac{5}{8}$ " BSF Socket Head Cap Screw 2" long
6	154/10	$\frac{5}{8}$ " Spring Washer
7	155/0840	$\frac{1}{2}$ " BSF Socket Head Cap Screw 2 $\frac{1}{2}$ " long
8	154/08	$\frac{1}{2}$ " Spring Washer
9	155/0832	$\frac{1}{2}$ " BSF Socket Head Cap Screw 2" long
10	154/08	$\frac{1}{2}$ " Spring Washer
11	515Z.101A	Hydraulic Tank
12	169/0/14	7/16" BSF Hexagon Head Set Screw $\frac{7}{8}$ " long
13	198/14	7/16" Lock Washer
14	515X.129	Stem
15	160/208	2BA Dome Head Screw $\frac{1}{2}$ " long
16	515Y107A	Pressure Gauge Plate
17	ADW 3	Pressure Switch Square D
18	ACW 1	Pressure Switch Square D
19	155/0428	$\frac{1}{4}$ " BSF Socket Head Cap Screw 1 $\frac{1}{2}$ " long
20	D100L	2HP, 1000 R.P.M. Motor
21	198/14	7/16" Lock Washer
22	169/0/20	7/16" BSF Hexagon Head Set Screw 1 $\frac{1}{4}$ " long
23	160/206	2BA Dome Head Screw $\frac{3}{8}$ " long
24	250/20NE	Oil Level Window
25	155/0514	5/16" BSF Socket Head Cap Screw $\frac{1}{4}$ " long
26	154/05	5/16" Spring Washer
27	1 DT	Roseán Tell-Tale Filter
28	515X.157	Flexible Connector
29	-	$\frac{1}{4}$ " BSP Magnetic Plug
30-33	GP.140N FLS	Smiths Pressure Gauge 3"
34	-	For all Valve & Pipe References see:- 315Z.4 - 6 $\frac{1}{8}$ "-6H 215Z.4 - 5 $\frac{1}{8}$ "-6H

List of Parts for
Plate No.2
(Drawing No.315Z1)

WHEN ORDERING SPARE PARTS ALWAYS QUOTE THE INSPECTION NUMBER OF THE MACHINE

**HYDRAULIC SUPPLEMENT
6 1/4" - 6 CHUCKING MACHINES**

304 Z 4 SPINDLE STOPPING UNIT. HYDRAULIC CHUCKING AUTOS

6 $\frac{3}{4}$ " - 6H, 6 $\frac{3}{4}$ " - 6HD MACHINES. SECTIONS 304H, 304HD

INDEX NO.	PART NO.	TITLE	INDEX NO.	PART NO.	TITLE
1	—	Section	38	—	Housing (See Table)
2	—	Machine	39	B 1812	Torrington Needle Roller Bearing, 1 $\frac{1}{8}$ " bore x 1 $\frac{3}{8}$ " o.dia. x $\frac{3}{4}$ " long
3	—	Cranked Shaft	40	121/0820T	Key, Tapped, $\frac{1}{4}$ " square x 1 $\frac{1}{4}$ " long
4	—	Clutch Shoe	41	304X.125	Bearing Housing
6	—	Slide	42	155/0410	Socket Head Cap Screw, $\frac{1}{4}$ " B.S.F. x $\frac{3}{8}$ " long
6	—	Switch Bracket, Left Hand	43	164/04	Spring Washer, for $\frac{1}{2}$ " dia.
7	—	Use Holes marked :-	44	212/18	Nipple, $\frac{1}{8}$ " B.S.P.
8	—	Switch Bracket, Right Hand	45	210/2525	Indicator Washer, for $\frac{1}{8}$ " B.S.P.
9	—	Use Holes marked :-	46	—	Cranked Shaft (See Table)
10	—	Support Plate	47	B 1212	Torrington Needle Roller, $\frac{3}{4}$ " bore x 1" o.dia. x $\frac{3}{4}$ " long
11	—	Trip Cam	48	101/6	External Circlip, $\frac{3}{4}$ "
12	—	Legend Plate	49	304X.123	Gear
		Bracket, Left Hand	50	304X.122	Operating Rack
		Bracket, Right Hand	51	304X.132	Stop Housing
13	—	Slide (See Table)	52	—	Trip Cam (See Table)
14	304X.128	Slide Guide	53	167/0614	Hexagon Head Set Screw, $\frac{3}{8}$ " B.S.F. x $\frac{7}{8}$ " long
15	236/202424	Oil Retaining Bush, 1 $\frac{1}{4}$ " bore x 1 $\frac{1}{2}$ " o.dia. x 1 $\frac{1}{2}$ " long	54	197/12	Shakeproof Washer, for $\frac{3}{8}$ " dia.
16	—	Clutch Shoe (See Table)	55	16D 1200	" Snap-Lock " Limit Switch, Series 16D 1200
17	141/3	Taper Pin, Tapped, 11/32" dia. x 1 $\frac{1}{4}$ " long	56	141/3	Taper Dowel, 11/32" dia. x 1 $\frac{1}{4}$ " long
18	304X.121	Roller	57	—	Right-Hand Bracket (See Table)
19	B 1212	Torrington Needle Roller, $\frac{3}{4}$ " bore x 1" o.dia. x $\frac{3}{4}$ " long	58	173/06L	Selflocking Nut, $\frac{3}{8}$ " B.S.F.
20	304X.120	Operating Pad	59	183/0632	Square Head Set Screw, Taper Point, $\frac{3}{8}$ " B.S.F.
21	127/0408	Cotter Pin, 1/16" dia. x 1" long	60	163/05	Soft Pad, for 5/16" dia.
22	304X.120	Operating Pad	61	176/0514	Socket Set Screw, 5/16" B.S.F. x $\frac{7}{8}$ " long
23	154/05	Spring Washer, for 5/16" dia.	62	183/0824	Square Head Set Screw, Taper Point, $\frac{3}{8}$ " B.S.F. x 1 $\frac{1}{2}$ " long
24	165/0514	Socket Head Cap Screw, 5/16" B.S.F. x $\frac{7}{8}$ " long	63	173/06L	Selflocking Nut, $\frac{3}{8}$ " B.S.F.
25	304X.128	Slide Guide	64	210/2525	Indicator Washer, for $\frac{1}{8}$ " B.S.P.
26	236/202424	Oil Retaining Bush, 1 $\frac{1}{4}$ " bore x 1 $\frac{1}{2}$ " o.dia. x 1 $\frac{1}{2}$ " long	65	212/9018	Autolub Nipple, $\frac{1}{8}$ " B.S.P.
27	127/0405	Cotter Pin, 1/16" dia. x $\frac{5}{8}$ " long	66	304V.133A	" Maxam " Hydraulic Cylinder
28	304X.126	Spring Pin	67	173/07L	Selflocking Nut, 7/16" B.S.F.
29	304X.109	Eye Bolt	68	164/04	Spring Washer, for $\frac{1}{2}$ " dia.
30	304X.124	Shoe Spring	69	155/0414	Socket Head Set Screw, $\frac{1}{4}$ " B.S.F. x $\frac{7}{8}$ " long
31	304X.110	Washer	70	210/2625	Indicator Washer, for $\frac{1}{8}$ " B.S.P.
32	176/06	Socket Set Screw, $\frac{3}{8}$ " B.S.F.	71	212/9018	Autolub Nipple, $\frac{1}{8}$ " B.S.P.
33	173/06L	Selflocking Nut, $\frac{3}{8}$ " B.S.F.	72	130/05	Flat Washer, for 5/16" dia.
34	178/0636	Socket Set Screw, Dog Point, $\frac{3}{8}$ " B.S.F. x 2 $\frac{1}{2}$ " long	73	167/0510	Hexagon Head Set Screw, 5/16" B.S.F. x $\frac{3}{8}$ " long
35	291/	Legend Plate (See Table)	74	—	Left-Hand Bracket (See Table)
36	155/0512	Socket Head Cap Screw, 5/16" B.S.F. x $\frac{3}{4}$ " long			
37	154/05	Spring Washer, for 5/16" dia.			

List Of Parts for
Plate No. 1
(Drawing No. 304 Z 4)

WHEN ORDERING SPARE PARTS ALWAYS QUOTE THE INSPECTION NUMBER OF THE MACHINE

ARRANGEMENT OF SPINDLE STOPPING CAMS WITH COLLET AND BAR FEED MECHANISM

2¼" - 6 SPINDLE STOPPER BAR MACHINES

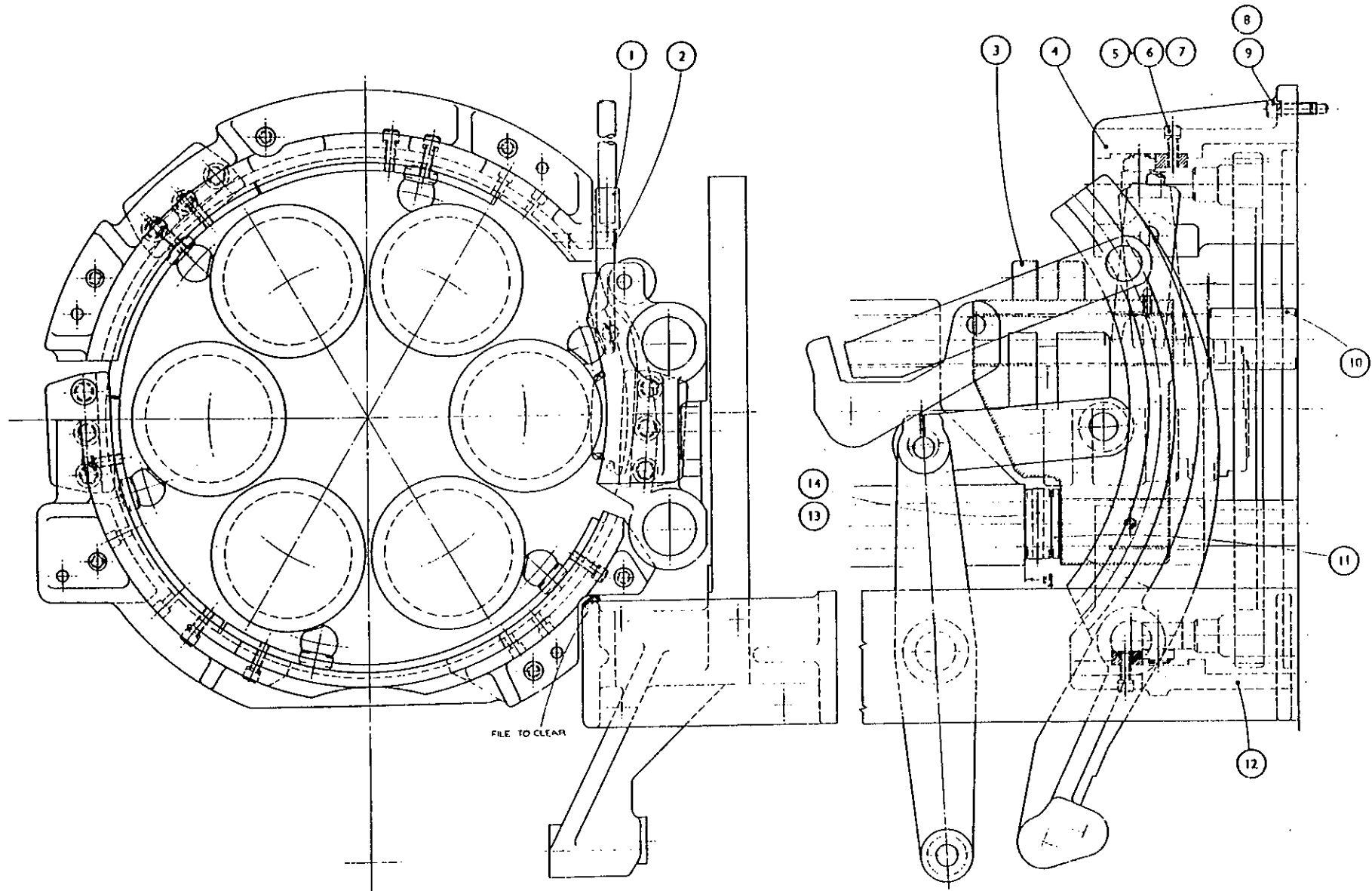

302 Z 4 ARRANGEMENT OF SPINDLE-STOPPING CAMS

2 1/4" - 6S MACHINE. SECTION 302

INDEX NO.	PART NO.	TITLE	INDEX NO.	PART NO.	TITLE
1	--	Spindle stop & remain stopped in station:	28	--	Stop
2	154/07	Spring Washer, for 7/16" dia.	29	--	Start
3	155/0720	Socket Head Cap Screw, 7/16" B.S.F. x 1 1/2" long	30	--	Start
4	--	Start	31	--	Stop
5	--	Start	32	--	Stop
6	--	Start	33	--	Stop
7	--	Start	34	--	Stop
8	--	Start	35	--	Stop
9	--	Stop	36	--	Stop
10	--	Start	37	--	Stop
11	--	Stop	38	--	Stop
12	--	Start	39	--	Start
13	--	Stop	40	--	Stop
14	--	Start	41	--	Stop
15	--	Stop	42	--	Stop
16	--	Start	43	--	Stop
17	--	Stop	44	--	Stop
18	--	Start	45	--	Stop
19	--	Stop	46	--	Stop
20	--	Stop	47	--	Stop
21	--	Start	48	--	Stop
22	--	Stop	49	--	Stop
23	--	Stop	50	--	Stop
24	--	Start	51	--	Stop
25	--	Stop	52	--	Stop
26	--	Stop	53	302X.228	Stop
27	--	Stop			

Fit this cam as standard except when stop in Station 1 is required.

List of Parts for
Plate No. 64
(Drawing No. 302 Z 4)

WHEN ORDERING SPARE PARTS ALWAYS QUOTE THE INSPECTION NUMBER OF THE MACHINE

SPINDLE ARRANGEMENT, END VIEWS
 2 1/4" - 6 SPINDLE STOPPER BAR MACHINES

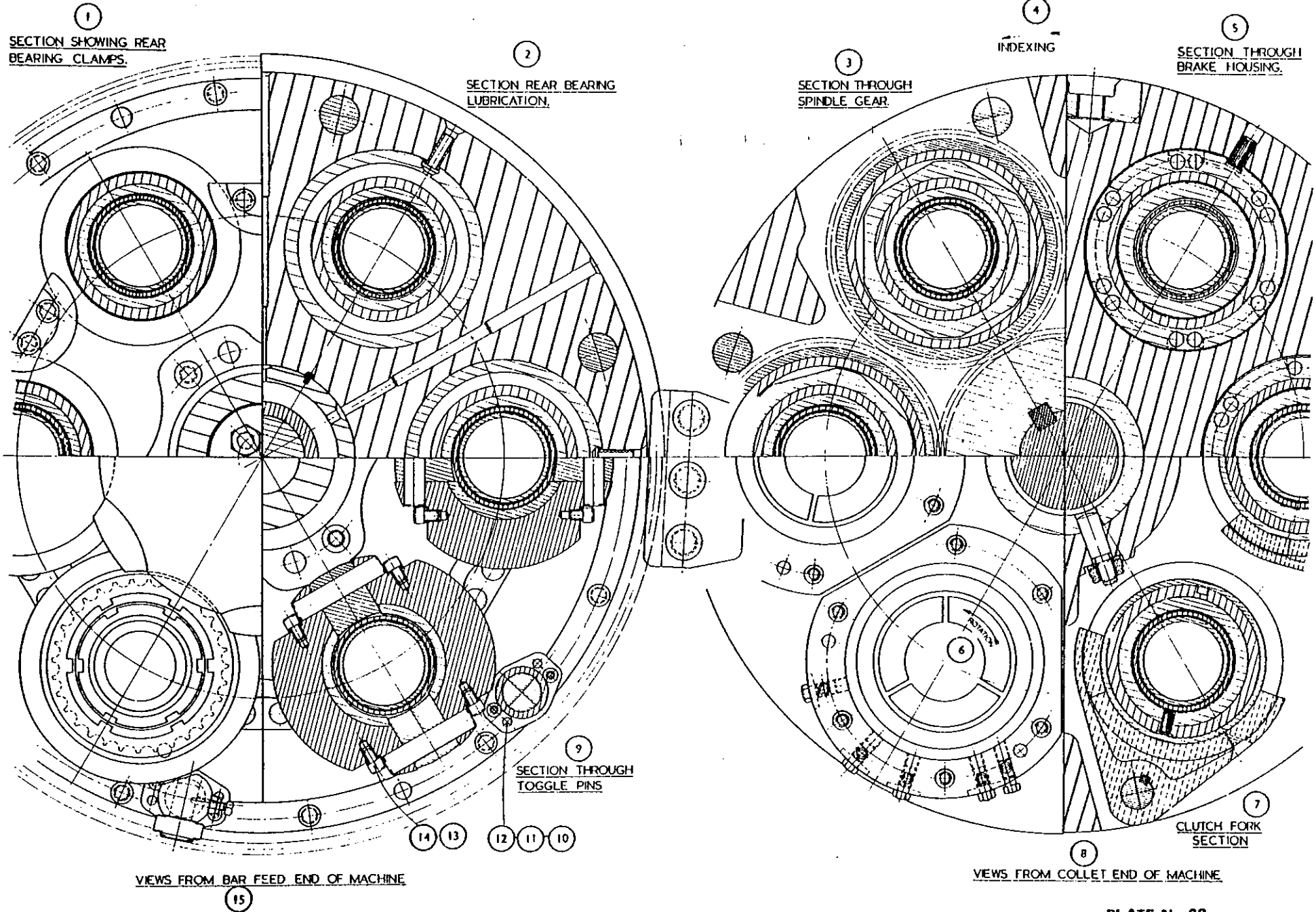

302 Z 3 ARRANGEMENT OF SPINDLE-STOPPING CAMS WITH COLLET & BAR FEED MECHANISM

2¼"- 6S MACHINE. SECTION 302

INDEX NO.	PART NO.	TITLE
1	302V.211	Hand Adjustment Lever
2	126/2032	Parallel Pin, 5/8" dia. x 2" long
3	302Z.250	Collet Operating Slide
4	302Z.226/2	Cam Support Bracket
5	154/07	Spring Washer, for 7/16" dia.
6	155/0720	Socket Head Cap Screw, 7/16" B.S.F. x 1½" long
7	141/14	Taper Pin, ½" dia. x 2" long
8	154/08	Spring Washer, for ½" dia.
9	155/0824	Socket Head Cap Screw, ½" B.S.F. x 1½" long
10	302X.252	Stop Collar
11	356X.190	Stop Collar (Section 356)
12	302Z.226/1	Cam Support Bracket
13	125/3248	Taper Pin, ½" dia. x 3" long (Section 358)
14	358X.162	Stop Collar (Section 358)

List of Parts for
Plate No. 63
(Drawing No. 302 Z 3)

WHEN ORDERING SPARE PARTS ALWAYS QUOTE THE INSPECTION NUMBER OF THE MACHINE

SPINDLE ARRANGEMENT
 2 1/4" - 6 SPINDLE STOPPER BAR MACHINE

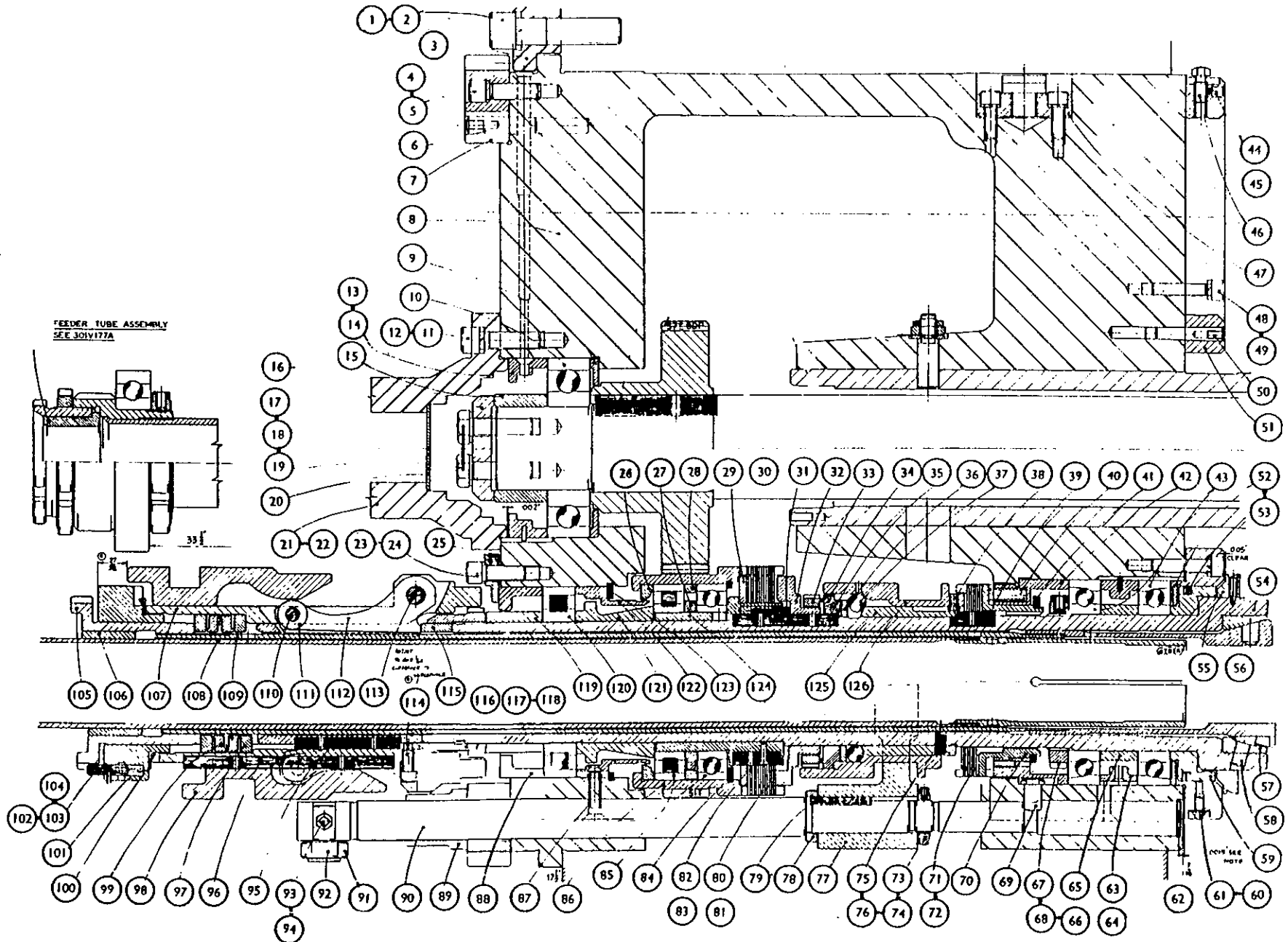

302 Z 2 SPINDLE ARRANGEMENT, END VIEWS

2¼"-6S MACHINE. SECTION 302

INDEX NO.	PART NO.	TITLE
1	--	Section showing Rear Bearing Clamps
2	--	Section Rear Bearing Lubrication
3	--	Section through spindle gear
4	--	Indexing
5	--	Section through Brake Housing
6	--	Rotation
7	--	Clutch Fork Section
8	--	Views from Collet end of machine
9	--	Section through Toggle Pins
10	125/1620	Taper Pin, ¼" dia. x 1¼" long
11	154/04	Spring Washer, for ¼" dia.
12	155/0412	Socket Head Cap Screw, ¼" B.S.F. x ¾" long
13	154/05	Spring Washer, for 5/16" dia.
14	155/0518	Socket Head Cap Screw, 5/16" B.S.F. x ¾" long
15	--	Views from Bar Feed end of machine

List of Parts for
Plate No. 62
(Drawing No. 302 Z 2)

WHEN ORDERING SPARE PARTS ALWAYS QUOTE THE INSPECTION NUMBER OF THE MACHINE

302 Z 1 SPINDLE ARRANGEMENT

2 1/4" - 6S MACHINE. SECTION 302

INDEX NO.	PART NO.	TITLE	INDEX NO.	PART NO.	TITLE
74	179/204	Set Screw, 2 B.A. x 1/4" long	102	501X.129A	Plunger
75	102X.146	Bronze Dowel	103	125/1008	Taper Pin, 5/32" dia. x 1/2" long
76	153/42	Soft Pad, for 2 B.A.	104	501X.125	Spring, Plunger
77	303V.207	Clutch Fork	105	302X.126	Adjusting Sleeve, Collet Tube
78	303X.209	Clutch Glut Spacer	106	301X.162	Support Bush, Feed Tube
79	122/082B	Key, 1/4" x 3/16" x 1 1/4" long	107	302X.110	Toggle Carrier
80	302X.188	Driving Clutch Plate, Inner	108	301X.161B	Feed Tube
81	302X.189	Driving Clutch Plate, Outer	109	301X.170A	Collet Tube
82	202X.216	Clutch Key	110	301X.106	Pin, Toggle Roller
83	162/410	Countersunk Head Screw, 4 B.A. x 5/8" long	111	501X.207A	Roller, Toggle
84	—	Seeger Circlip, Internal, 5 3/8"	112	501V.204	Toggle
85	S866	Spindle Gear Bearing	113	501X.195	Pin, Toggle
86	302V.112	Spindle Gear	114	501X.250	Retaining Screw
87	511X.172A	Lubricant Guide Bush	115	302X.113	Thrust Pad
88	302X.121	Rear Bearing End Cap	116	302X.242	Retaining Nut
89	302X.185	Glut Rod Bearing	117	176/0405	Socket Set Screw, Cup Point, 1/4" B.S.F. x 5/16" long
90	302V.210	Clutch Operating Shaft	118	153/04	Soft Pad, for 1/2" dia.
91	394X.187A	Roller	119	302X.124	Spacer, Rear Bearing
92	394X.196	Pin	120	S865	Rear Spindle Bearing
93	183/0416	Square Head Set Screw, Taper Point, 1/4" B.S.F. x 1" long	121	302X.123	Rear Bearing Spacer
94	203/04	Selflocking Nut, 1/4" B.S.F.	122	302X.120	Rear Bearing Inner Spacer
95	302X.190	Key	123	104/50P	Internal Circlip, 140mm
96	122/1696T	Key, Tapped, 1/4" x 1 1/32" x 6" long	124	302X.217	Clutch Centre
97	302X.261	Spacing Washer	125	302X.182	Clutch Centre
98	302V.111	Toggle Operating Sleeve	126	302X.181	Clutch Bobbin
99	302X.122	Compensating Washer			
100	302X.165	Tab Washer			
101	302X.127	Plunger Housing			

List of Parts for
Plate No. 61
(Drawing No. 302 Z 1)

WHEN ORDERING SPARE PARTS ALWAYS QUOTE THE INSPECTION NUMBER OF THE MACHINE

Handwritten text, possibly bleed-through from the reverse side of the page, located along the right edge.

STOCK CARRIAGE
2 1/4"-6 AND 2 1/4"-6D BAR MACHINES

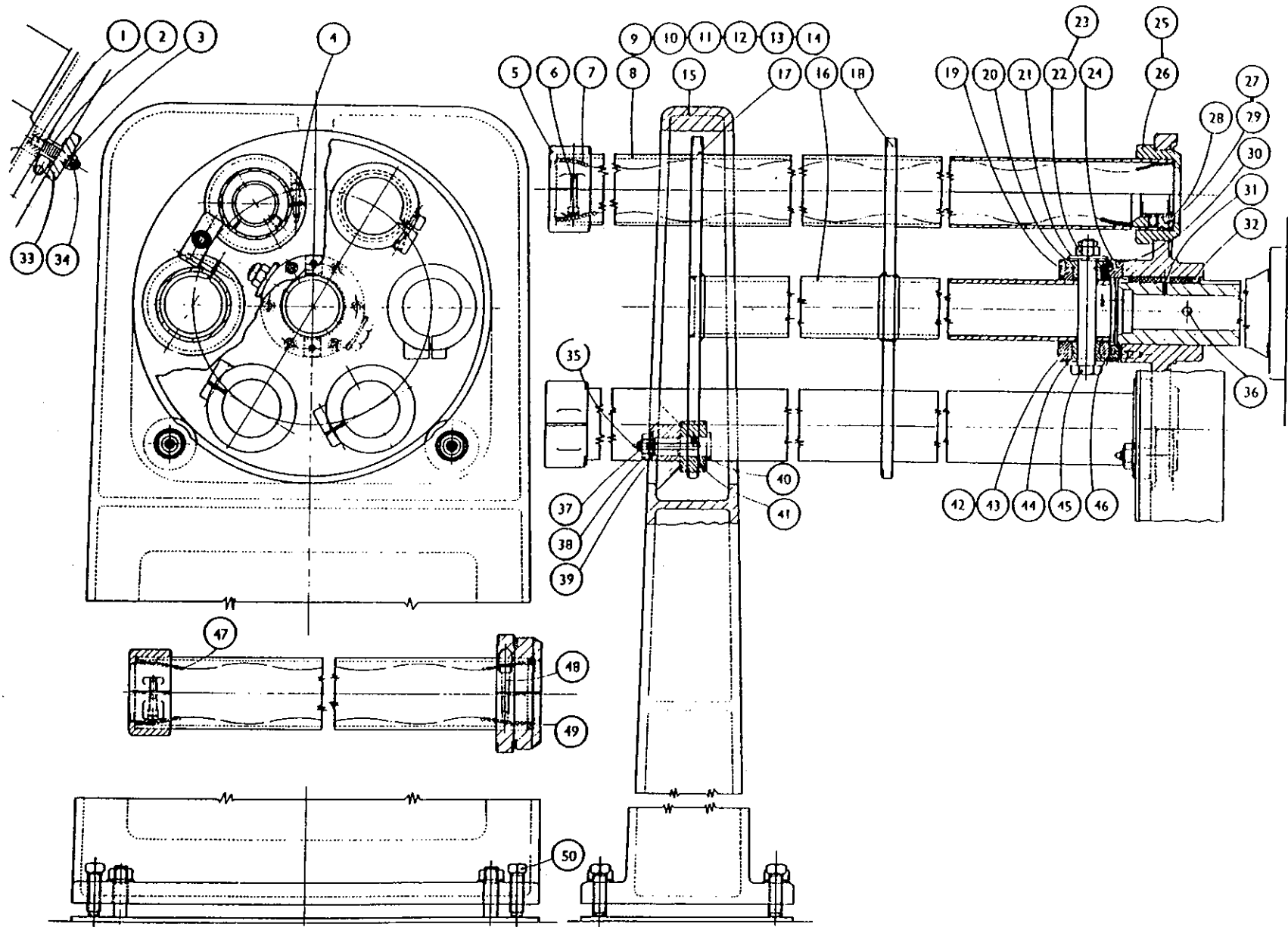

302 Z 1 SPINDLE ARRANGEMENT

2 1/4" - 6S MACHINE. SECTION 302

INDEX NO.	PART NO.	TITLE	INDEX NO.	PART NO.	TITLE
1	154/12	Spring Washer, for 3/4" dia.	37	-	Hardened Steel Ball, 13 mm dia.
2	155/1248	Socket Head Cap Screw 3/4" B.S.F. x 3" long	38	102X.197C	Brake Housing Key
3	301X.163	Thrust Block	39	302X.200	Key for Brake Clutch
4	154/07	Spring Washer, for 7/16" dia.	40	302X.199	Brake Spring
5	155/0724	Socket Head Cap Screw, 7/16" B.S.F. x 1 1/2" long	41	-	Seeger Circlip, External, 4.5/16"
6	141/14	Taper Pin, 1/2" dia. x 2" long	42	302V.196	Brake Housing
7	394X.186 A	Index Gear Modification	43	5864	Front Spindle Bearing
8	302Z.101	Spindle Drum	44	176/0506	Socket Set Screw, Cup Point, 5/16" B.S.F. x 3/8" long
9	317X.153	Spacer	45	153/05	Soft Pad, for 5/16" dia.
10	257/60	Ball Journal, Medium Type, Metric	46	301X.158	Stop Screw
11	155/0828	Socket Head Cap Screw, 1/2" B.S.F. x 1 3/4" long	47	301X.148	Locator
12	154/08	Spring Washer, for 3/4" dia.	48	155/0628	Socket Head Cap Screw, 3/4" B.S.F. x 1 1/4" long
13	143/0408D	Mills Pin, 1/4" dia. x 3/8" long	49	154/06	Spring Washer, for 3/8" dia.
14	317X.149	Centre Bearing End Spacer	50	141/10	Taper Pin, 11/32" dia. x 2" long
15	317X.154	Centre Bearing Inner Spacer	51	303V.1148	Binding Cap, Spindle Front Bearing
16	317X.145	Supplied by Tooling. Feeder Tube Assembly, see 301V.177A	52	302X.160	Labyrinth Ring
16 A	-		53	301X.116	Piston Ring
17	-	Soft Iron Wire	54	302Z.102B	Work Spindle
18	198/16	Shakeproof Washer, for 1/2" dia.	55	301X.103	Thrower Ring
19	317X.144	Belt	56	182/0412	Socket Set Screw, Taper Point, 1/4" B.S.F. x 3/4" long
20	129/29	Welch Plug	57	301X.147	Spindle Nose
21	301Y.165 A	Driving Coupling	58	301X.148A	Driving Key, Collet
22	301X.173	Parallel Pin	59	302X.115B	Ring Housing
23	154/07	Spring Washer, for 7/16" dia.	60	210/1725	Indicator Washer, Yellow
24	155/0720	Socket Head Cap Screw, 7/16" B.S.F. x 1 1/2" long	61	212/04	Nipple, 1/4" B.S.F.
25	302X.180	Clamp, Rear Bearing Cap	62	129/15	Welch Plug, 1 1/2"
26	302X.241	End Spacer	63	302X.117	Front Bearing Spacer
27	302X.221A	Inner Spacer	64	143/04060	Mills Pin, 1/4" dia. x 3/8" long
28	302X.222	Outer Spacer	65	302X.159	Spacer
29	302X.186	Thrust Plate	66	176/0506	Socket Set Screw, Cup Point, 5/16" B.S.F. x 3/8" long
30	202X.218	Pin	67	172/100	Slotted Locknut, 100mm
31	303X.220A	Clutch Spring	68	163/05	Soft Pad, for 5/16" dia.
32	302X.193	Thrust Ring	69	302X.226 A	Drive Key, Brake
33	302X.201	Clutch Adjusting Nut	70	302X.196	Brake Pressure Sleeve
34	302X.184	Adjustment Ring	71	302X.197	Brake Clutch Plate, Inner
35	121/1248T	Key, Tapped, 3/8" square x 3" long	72	302X.198	Brake Clutch Plate, Outer
36	302X.202	Thrust Plate	73	303X.227	Locknut

List of Parts for
Plate No. 61
(Drawing No. 302 Z 1)

WHEN ORDERING SPARE PARTS ALWAYS QUOTE THE INSPECTION NUMBER OF THE MACHINE

STOCK CARRIAGE
2"-6 AND 2"-6D BAR MACHINES

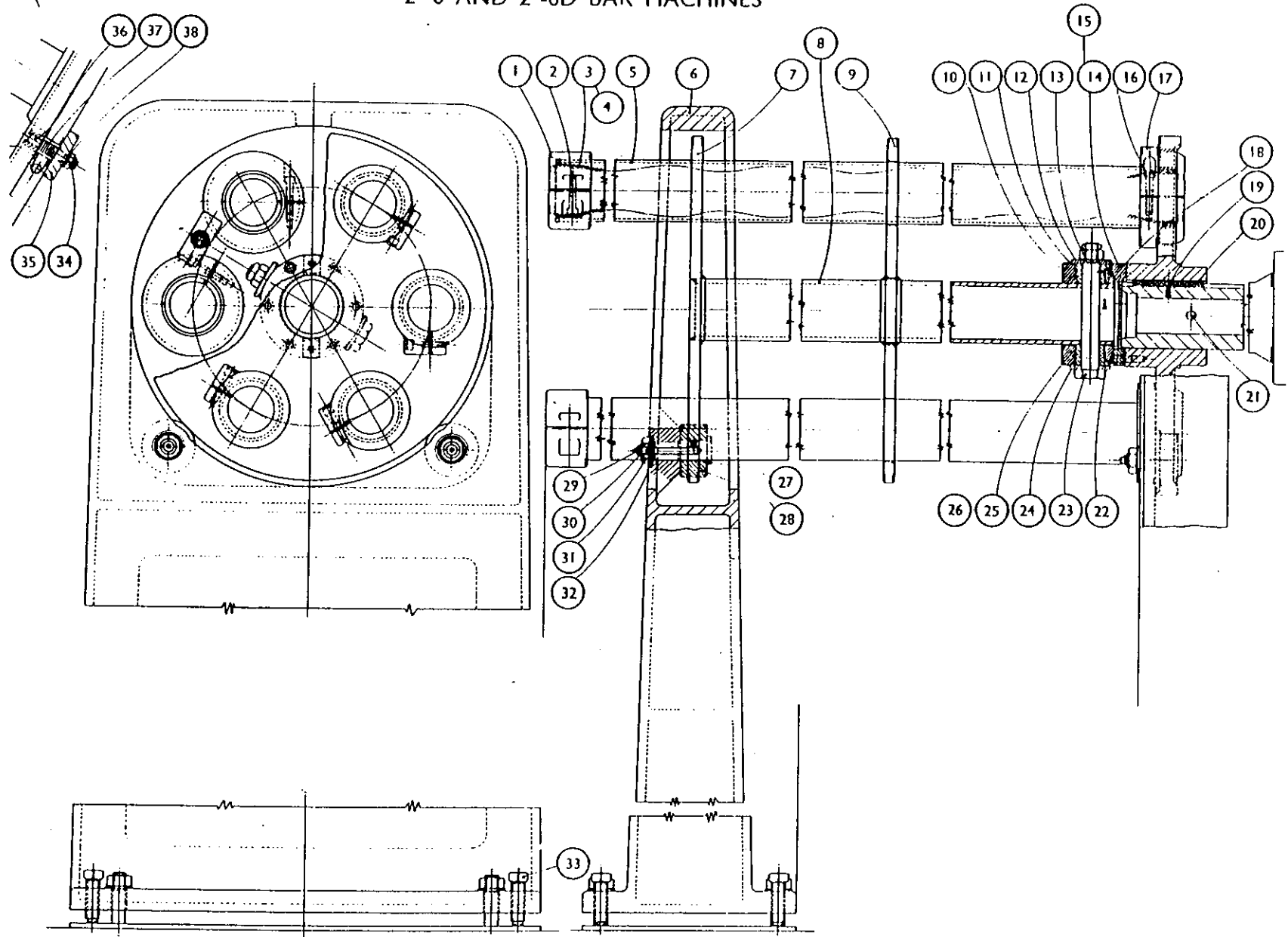

**WICKMAN
MULTI-SPINDLE
AUTOMATICS**

**STOCK CARRIAGE
2¼"-6 AND 2¼"-6D BAR MACHINES**

INDEX NO.	PART NO.	TITLE.	INDEX NO.	PART NO.	TITLE.
1	575X.111A	Stud.	26	375V.153	Bush for Stock Tube.
2	575X.122	Spring.	27	176/0808	¾" B.S.F. Socket Set Screw, Cup Point, ½" long.
3	130/08	¾" Plain Washer.	28	375X.127	Washer.
4	155/0624	¾" B.S.F. Cap Screw, 1½" long.	29	375X.136	Adaptor for Steady Bush.
5	575Y.104A	Spring Retaining Cap.	30	375X.133	Tenon.
6	155/0628	¾" B.S.F. Cap Screw, 1½" long.	31	156/210	2 B.A. Socket Head Cap Screw, ¾" long.
7	375X.169	Stock Support Spring, 2½" capacity.	32	301X.172	Key.
	375X.170	Stock Support Spring, 1½" capacity.	33	576X.110	Clamp.
8	375X.151	Stock Tube.	34	203/08L	¾" B.S.F. Self-Locking Nut.
9	301Y.168	Feed Tube Steady.	35	212/18	¾" B.S.P. Oiler.
10	301Y.169	Stop Plate.	36	125/4088	¾" dia. Taper Pin, 5½" long.
11	558X.128	Spring.	37	210/2525	¾" B.S.P. Yellow Indicator Washer.
12	577X.123	Plunger Housing.	38	173/14L	¾" B.S.F. Hex. Locknut.
13	577X.125	Plunger.	39	130/14	¾" Plain Washer.
14	577X.126	Knob.	40	375X.116	Roller Pin.
15	375Z.108	Stock Carriage Stand.	41	575X.115	Roller.
16	375X.102	Centre Tube.	42	154/07	⅜" Spring Washer.
17	375V.156	Support Disc for Stock Tube.	43	155/0756	⅜" B.S.F. Cap Screw, 3½" long.
18	375V.156	Support Disc for Stock Tube.	44	CW.973	Harrisflex Bearing coated with Oil Resisting Synthetic Lacquer.
19	375Y.125	Adaptor.	45	375X.130	Pin.
20	CW.973	Harrisflex Bearing, coated with Oil Resisting Synthetic Lacquer.	46	375X.129	Washer.
21	375X.128	Washer.	47	575Y.119	Stock Support Spring.
22	203/12	¾" B.S.F. Self-Locking Nut.	48	155/0736	¾" B.S.F. Cap Screw, 2½" long.
23	154/05	⅜" Spring Washer.	49	575X.127	Stock Spring Abutment Washer.
24	155/0512	⅜" B.S.F. Cap Screw, ½" long.	50	188/1240	¾" B.S.F. Square Head Set Screw, 2½" long.
25	376V.103	Bush for Stock Tube.			

List of Parts for
PLATE No. 60
Drawing No. 375 (Z 2)

WHEN ORDERING SPARE PARTS ALWAYS QUOTE THE SERIAL NUMBER OF THE MACHINE

2 1/4"-6, 2 1/4"-6D, 2"-6 AND 2"-6D BAR MACHINES, 6 1/4"-6, 6 1/4"-6D CHUCKING MACHINES

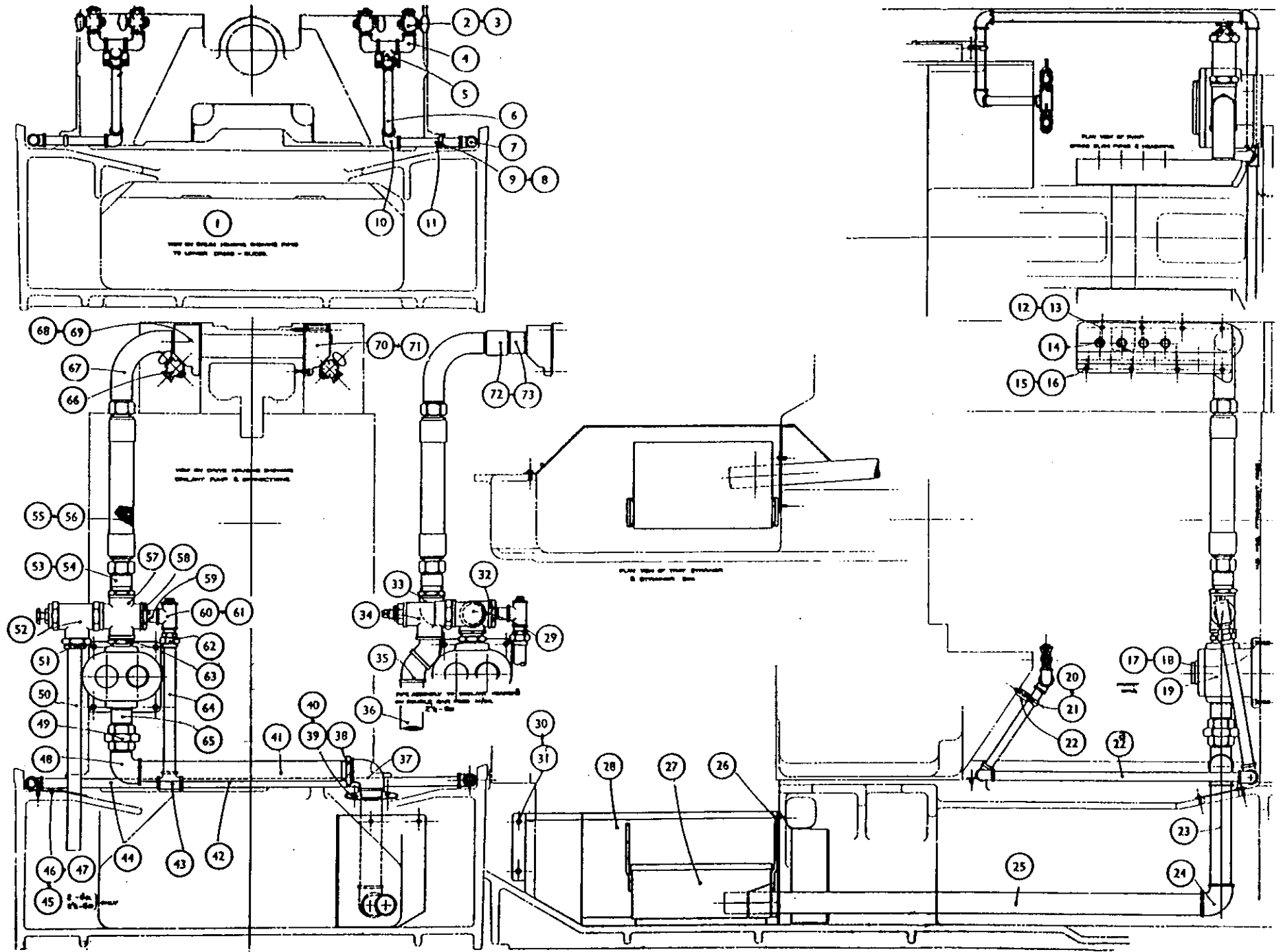

PLATE No.58A
(Drawing No.36922A)

**WICKMAN
MULTI-SPINDLE
AUTOMATICS**

**STOCK CARRIAGE
2"-6 AND 2"-6D BAR MACHINES**

INDEX NO.	PART NO.	TITLE.	INDEX NO.	PART NO.	TITLE.
1	375Y.104	Spring Retaining Cap.	20	301X.172	Key.
2	155/0628	$\frac{1}{4}$ " B.S.F. Socket Head Cap Screw, $1\frac{1}{2}$ " long.	21	125/4088	$\frac{1}{8}$ " dia. Taper Pin, $5\frac{1}{2}$ " long.
3	375X.119	Stock Support Spring (2" Cap).	22	375X.129	Washer.
4	375X.120	Stock Support Spring (1 $\frac{1}{2}$ " Cap, Special order only).	23	375X.130	Pin.
5	375X.101	Stock Tube.	24	CW.973	Bearing.
6	375Z.108	Stock Carriage Stand.	25	155/0756	$\frac{7}{16}$ " B.S.F. Socket Head Cap Screw, $3\frac{1}{2}$ " long.
7	375V.106	Support Disc for Stock Tube.	26	154/07	$\frac{1}{16}$ " Spring Washer.
8	375X.102	Centre Tube.	27	375X.116	Roller Pin.
9	375V.106	Support Disc for Stock Tube.	28	575X.115	Roller.
10	375Y.125	Adaptor.	29	212/18	$\frac{1}{4}$ " B.S.P. Oiler.
11	CW.973	Bearing.	30	210/2525	Yellow Indicator Washer.
12	375X.128	Washer.	31	173/14L	$\frac{1}{4}$ " B.S.F. Self Locking Nut (Thin).
13	203/12	$\frac{3}{4}$ " B.S.F. Self-Locking Nut.	32	130/14	$\frac{1}{4}$ " Flat Washer.
14	155/0512	$\frac{1}{16}$ " B.S.F. Socket Head Cap Screw, $\frac{1}{2}$ " long.	33	188/1240	$\frac{1}{4}$ " B.S.F. Square Head Set Screw, $2\frac{1}{2}$ " long.
15	154/05	$\frac{1}{16}$ " Spring Washer.	34	576X.110	Clamp.
16	155/0632	$\frac{1}{2}$ " B.S.F. Socket Head Cap Screw, 2" long.	35	203/08L	$\frac{1}{2}$ " B.S.F. Self-Locking Nut (Thin).
17	375V.103	Bush for Stock Tube.	36	575X.111A	Stud.
18	375X.133	Tenon.	37	575X.122	Spring.
19	156/210	2 B.A. Socket Head Cap Screw, $\frac{1}{2}$ " long.	38	130/08	$\frac{1}{2}$ " Flat Washer.

List of Parts for
PLATE No. 59
(Drawing No. 375 Z 1)

WHEN ORDERING SPARE PARTS ALWAYS QUOTE THE SERIAL NUMBER OF THE MACHINE

COOLANT PUMP DRIVE

2¼"-6, 2¼"-6D, 2"-6 AND 2"-6D BAR MACHINES

6⅝"-6 AND 6⅝"-6D CHUCKING MACHINES

M/C	2" - 6	6.5/8" - 6	
MOTOR R.P.M.	1450	1450	900
SPROCKET	369x112	369x112	369x118
SPROCKET SLEEVE	369x105	369x105	
CHAIN	B. S. No7 94 P	B. S. No7 94 P	B. S. No7 89 P

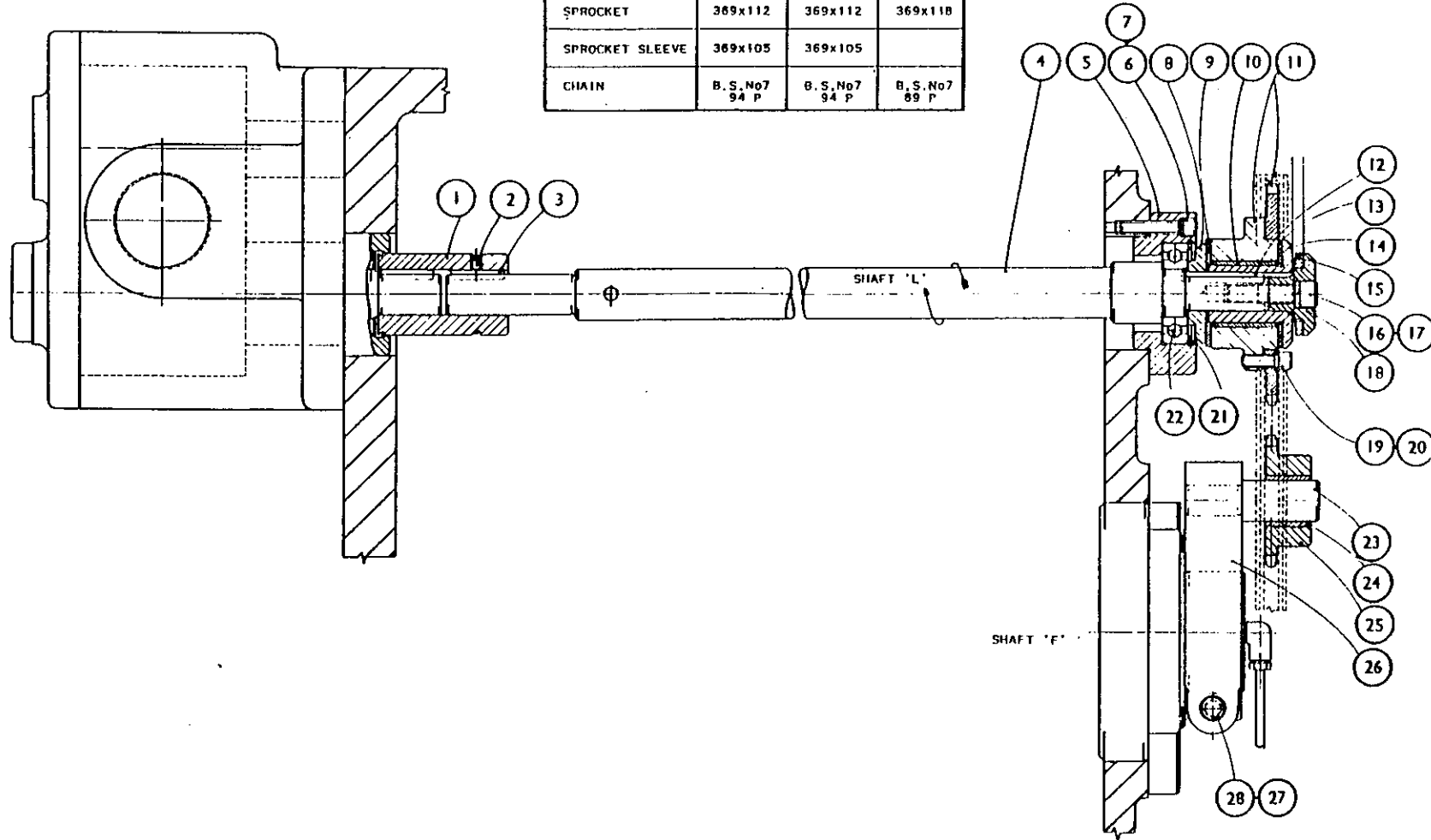

List of Parts for
PLATE No. 58
 (Drawing No. 369 Z 5)

389 Z 2A COOLANT PIPES SYSTEM
2 1/4" - 6, 6 3/4" - 6 MACHINES. SECTION 369

INDEX NO.	PART NO.	TITLE	INDEX NO.	PART NO.	TITLE
1	—	View on drum housing showing pipes to lower cross-slides	38	—	Backnut, 2" B.S.P.
2	669X.119A	Tap, 3/4" B.S.P. Male and Female	39	369X.144	Suction Pipe Collar
3	194/6	Plug, 3/4" B.S.P.	40	164/0510	Slotted Round Head Screw, 5/16" B.S.F. x 3/8" long
4	—	Elbow, 90°, Male & Female	41	360/3229B	Steel Tube, 2" B.S.P. x 25 1/4" long
5	—	Equal Tee, 3/4" B.S.P.	42	360/12252B	Steel Tube, 3/4" B.S.P. x 31 1/2" long
6	360/1290B	Steel Tube, 3/4" B.S.P. x 11 1/4" long	43	—	Tee, 3/4" x 3/4" x 1"
7	—	Elbow, 90°, Female	44	360/12108B	Steel Tube, 3/4" B.S.P. x 13 1/2" long
8	168/0408	Hexagon Socket Countersunk Head Screw, 3/4" B.S.F. x 1/2" long	45	369X.146	Relief Pipe Collar (2" - 6, 2 1/4" - 6 only)
9	—	Pipe Support, 3/4" B.S.P.	46	369X.150	Relief Pipe Collar
10	—	Elbow, 90°, Female	47	164/0510	Slotted Round Head Screw, 5/16" B.S.F. x 5/8" long
11	360/1264B	Steel Tube, 3/4" B.S.P. x 8" long	48	—	Elbow, 90°, 2" B.S.P., Male and Female
12	164/06	Lockwasher, for 3/8" dia.	49	—	Union, 2" B.S.P., Female
13	155/0656	Socket Head Cap Screw, 3/8" B.S.F. x 1/2" long	50	360/20192A	Steel Tube, 1 1/4" B.S.P. x 24" long
14	194/6	Plug, 3/4" B.S.P.	51	—	Eccentric Bush, 2" B.S.P. to 1 1/4" B.S.P.
15	164/06	Lockwasher, for 3/8" dia.	52	—	Relief Valve, 2" B.S.P.
16	155/0624	Socket Head Cap Screw, 3/8" B.S.F. x 1 1/2" long	53	—	Backnut, 2" B.S.P.
17	164/06	Lockwasher, for 3/8" dia.	54	369X.147A	Pipe, 4" long
18	165/0624	Socket Head Cap Screw, 3/8" B.S.F. x 1 1/2" long	55	369X.151	Sealing Washer
19	369Y.1	Soda Pump	56	369V.138A	Hose Assembly, " Superflexit", 2" B.S.P.
20	164/0432	Slotted Round Head Screw, 3/4" B.S.F. x 2" long	57	—	Cross Red Steam, Foulks
21	—	Pipe Support, 3/4" B.S.P.	58	—	Reducer, 2" B.S.P. to 1" B.S.P.
22	669X.130	Support Block	59	360/1619B	Steel Tube, 1" B.S.P. x 2 1/4" long
23	360/32104B	Steel Tube, 2" B.S.P. x 13" long	60	—	Equal Tee, 1" B.S.P.
24	—	Elbow, 90° Female	61	—	Plug, solid, 1" B.S.P.
25	360/3246B	Steel Tube, 2" B.S.P. x 58" long	62	—	Union, 1" B.S.P., Male and Female
26	155/0508	Socket Head Cap Screw, 5/16" B.S.F. x 1/2" long	63	—	Nipple, hexagon, 2" B.S.P.
27	369Y.161	Coolant Strainer	64	360/16118B	Steel Tube, 1" B.S.P. x 14 1/4" long
28	369Y.162	Tray Strainer	65	360/3229B	Steel Tube, 2" B.S.P. x 3 1/2" long
29	—	Elbow, 90°, Male and Female	66	669X.119A	Tap, 3/4" B.S.P., Male and Female
30	130/05	Plain Washer, for 5/16" dia.	67	369V.129	Radius Pipe
31	155/0508	Socket Head Cap Screw	68	369V.113	Gasket
32	—	Side Outlet Tee, 2" B.S.P.	69	369Y.114	Coolant Header, Rear
33	—	Elbow, 90°, 2" B.S.P., Male and Female	70	369Y.116	Coolant Header, Front
34	—	Relief Valve, 2" B.S.P.	71	369V.113	Gasket
35	—	Elbow, 45°, 2" B.S.P., Male and Female	72	—	Socket, 2" B.S.P.
36	360/32192A	Steel Tube, 2" B.S.P. x 24" long	73	360/3229B	Steel Tube, 2" B.S.P. x 3 1/4" long
37	—	Elbow, 90°, 2" B.S.P., Female			

List of Parts for
Plate No. 58A
(Drawing No. 389 Z 2A)

WHEN ORDERING SPARE PARTS ALWAYS QUOTE THE INSPECTION NUMBER OF THE MACHINE

COOLANT PUMP

2¼"-6, 2¼"-6D, 2"-6 AND 2"-6D BAR MACHINES

6⅝"-6 AND 6⅝"-6D CHUCKING MACHINES

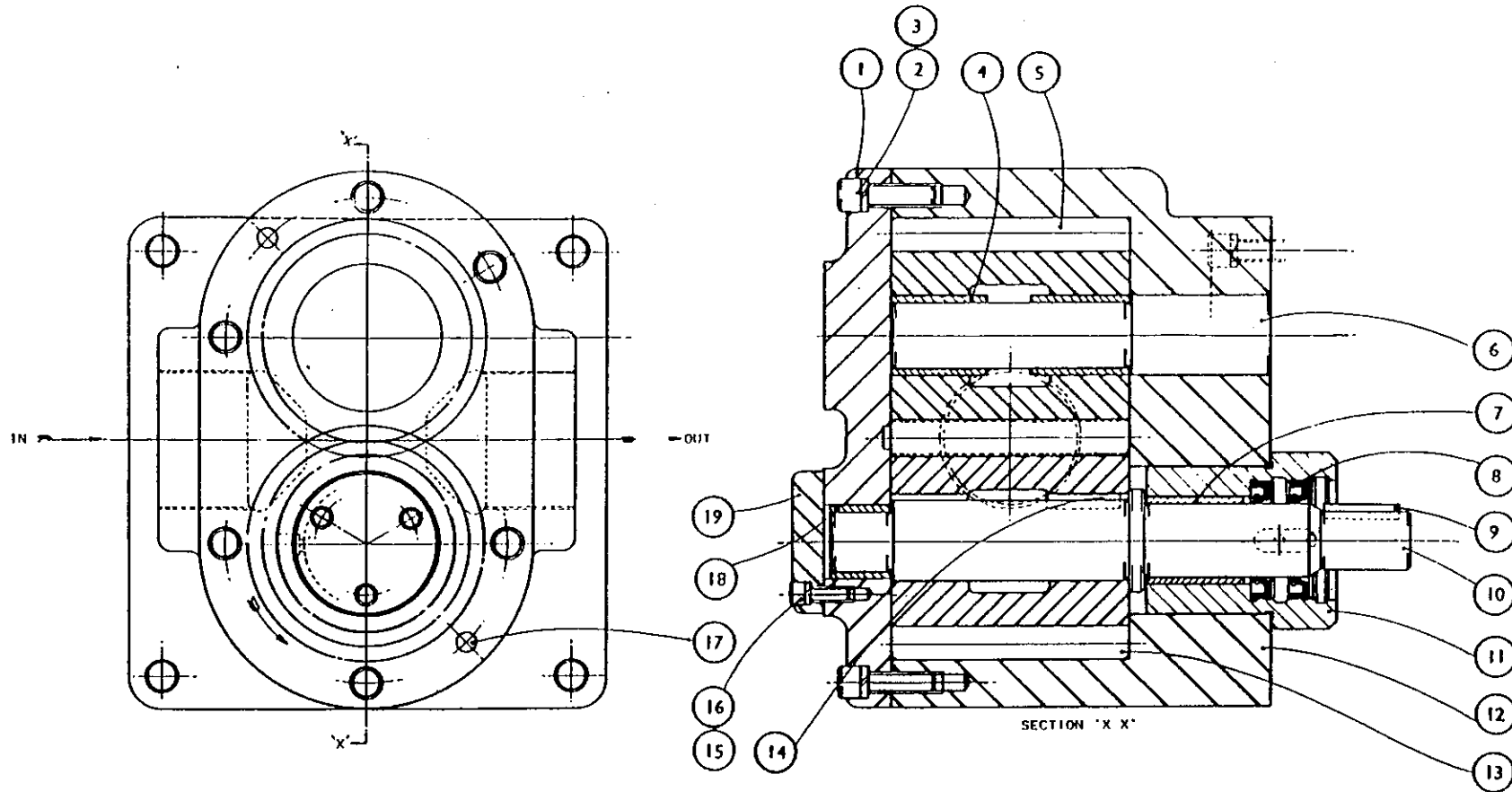

List of Parts for
PLATE No. 57
(Drawing No. 369 Y 1)

**WICKMAN
MULTI-SPINDLE
AUTOMATICS**

COOLANT PUMP DRIVE
2¼"- 6, 2½"-6D, 2"- 6 AND 2"- 6D BAR MACHINES
6½"- 6 AND 6¾"- 6D CHUCKING MACHINES

INDEX NO.	PART NO.	TITLE	INDEX NO.	PART NO.	TITLE
1	369X.131	Coupling	15	369X.135	Spring Washer
2	176/0404	¼" B.S.F. Socket Set Screw, ¼" long.	16	155/0728	7/16" B.S.F. Socket Head Cap Screw, 1½" long
3	121/0820	¼" Square Key, 1¼" long	17	164/07	7/16" Spring Washer
4	369X.130A	Drive Shaft	18	369X.136	Clamp
5	369X.132	Bearing Housing	19	155/0514	5/16" B.S.F. Socket Head Cap Screw, ¾" long
6	155/0524	5/16" B.S.F. Socket Head Cap Screw, 1½" long	20	164/05	5/16" Spring Washer
7	154/05	5/16" Spring Washer	21	104/33	Internal Circlip, 62mm
8	369X.133B	Thrust Washer	22	258/30	Light Ball Journal, 30 x 62 x 16mm
9	—	Oilite Washer	23	369X.140	Jockey Pin
10	236/222624	Oil Retaining Bush	24	236/162018	Oil Retaining Bush
11	—	See Table on Drawing	25	—	Pinion, 19T
12	121/0832T	¼" Square Key, 2" long	26	369X.141	Jockey Arm
13	369X.152	Oilite Washer	27	154/07	7/16" Spring Washer
14	369X.142A	Spined Sleeve	28	155/0736	7/16" B.S.F. Socket Head Cap Screw, 2¼" long

List of Parts for
PLATE No.58
(Drawing No.369 Z 5)

WHEN ORDERING SPARE PARTS ALWAYS QUOTE THE SERIAL NUMBER OF THE MACHINE

LUBRICATION PUMP

2¼"-6, 2¼"-6D, 2"-6 AND 2"-6D BAR MACHINES
6⅝"-6 AND 6⅝"-6D CHUCKING MACHINES

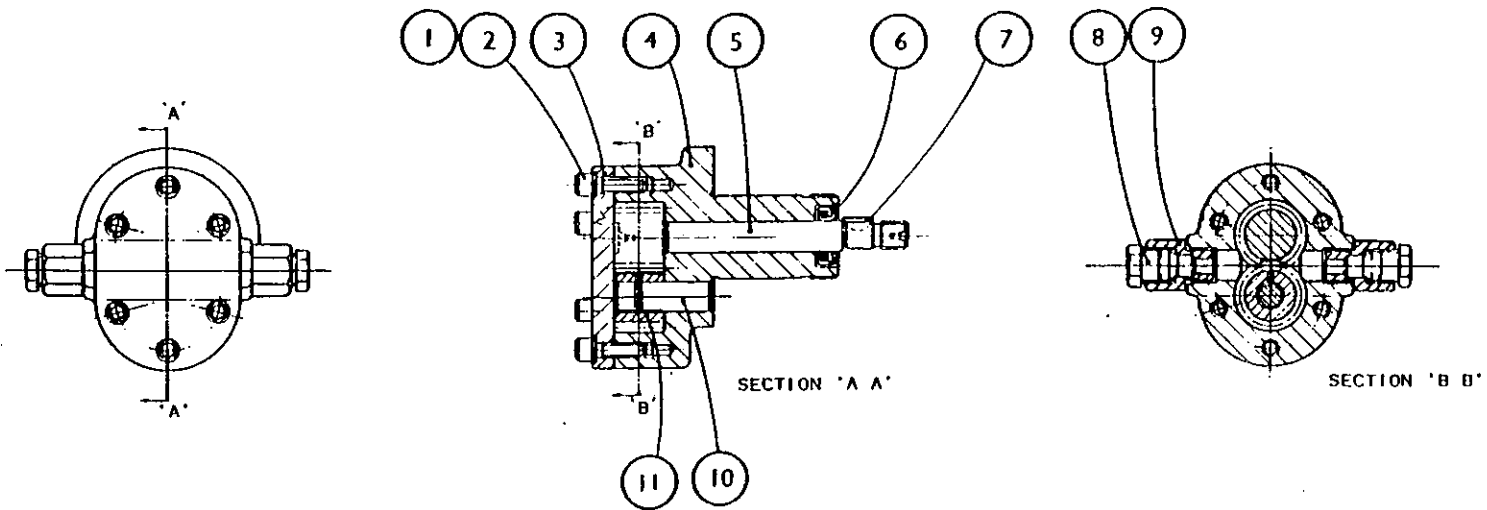
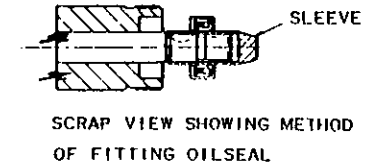
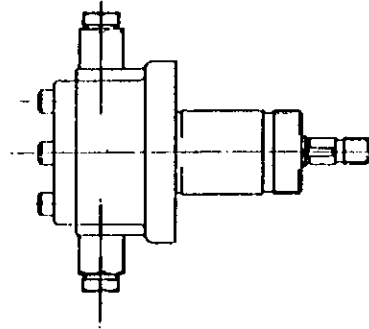

List of Parts for
PLATE No. 56
(Drawing No. 168 Z 1B)

**WICKMAN
MULTI-SPINDLE
AUTOMATICS**

COOLANT PUMP

2¼"-6, 2¼"-6D, 2"-6 AND 2"-6D BAR MACHINES
6⅝"-6 AND 6⅝"-6D CHUCKING MACHINES

INDEX NO.	PART NO.	TITLE.	INDEX NO.	PART NO.	TITLE.
1	169Y.103	Pump End Plate.	11	369X.106	Oil Seal Housing.
2	155/0620	¼" B.S.F. Socket Head Cap Screw, 1¼" long.	12	369Y.101	Pump Body.
3	154/06	¼" Spring Washer.	13	569X.104	Pump Gear.
4	236/182226	Oil Retaining Bush.	14	121/0820	¼" Square Key, 1¼" long.
5	569X.113	Driven Gear.	15	154/04	¼" Spring Washer.
6	369X.109	Idle Gear Stud.	16	155/0412	¼" B.S.F. Socket Head Cap Screw.
7	236/202425	Oil Retaining Bush.	17	141/3	⅜" dia. Taper Pin, 1¼" long.
8	235/20322G	Oil Seal.	18	236/162014	Oil Retaining Bush.
9	121/0820T	¼" Square Key, 1¼" long.	19	169X.110	End Cap.
10	369X.108	Pump Shaft.			

List of Parts for
PLATE No. 57
(Drawing No. 369 Y 1)

WHEN ORDERING SPARE PARTS ALWAYS QUOTE THE SERIAL NUMBER OF THE MACHINE

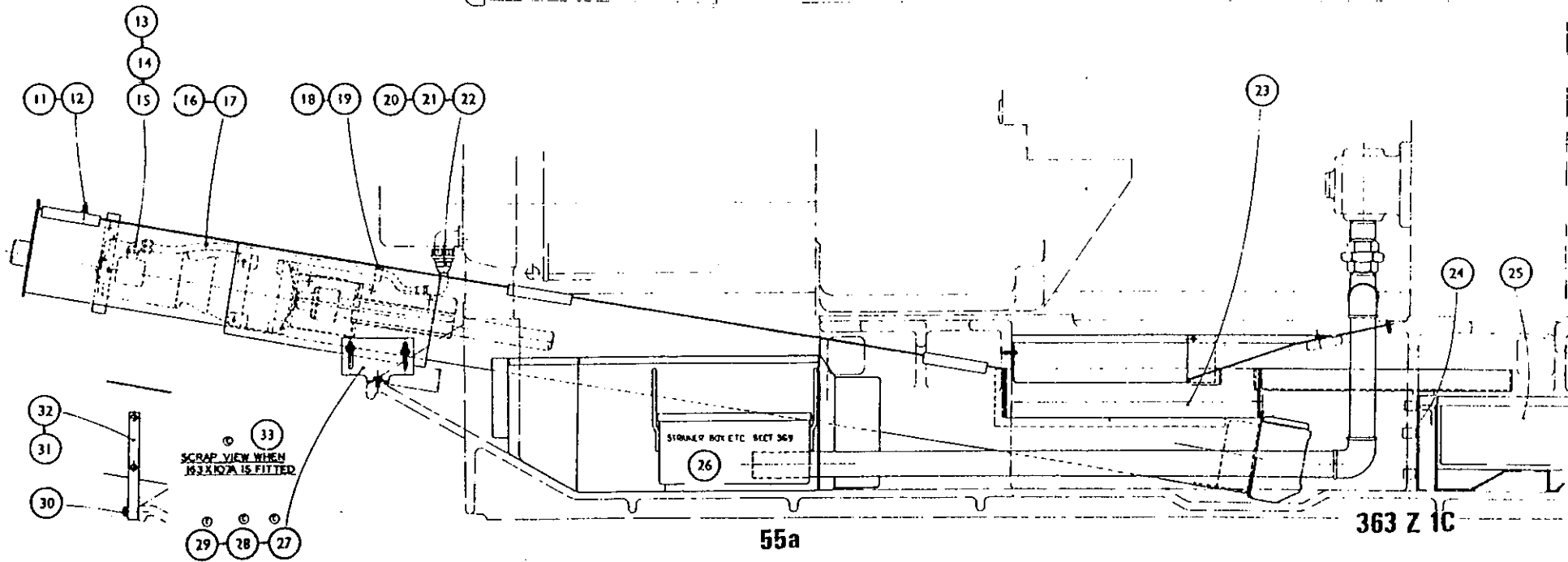
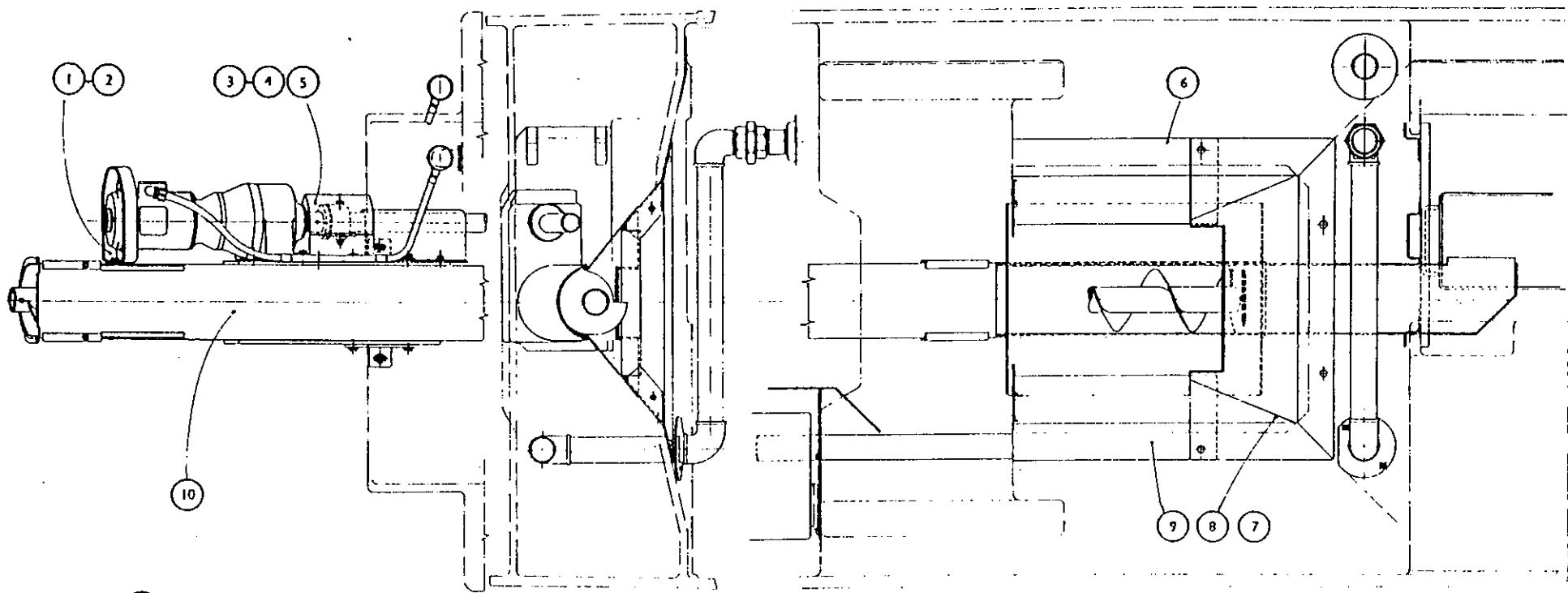

55a

363 Z 1C

**WICKMAN
MULTI-SPINDLE
AUTOMATICS**

LUBRICATION PUMP
2¼"-6, 2¼"-6D, 2"-6 AND 2"-6D BAR MACHINES
6⅜"-6 AND 6⅜"-6D CHUCKING MACHINES

INDEX NO.	PART NO.	TITLE.
1	154/04	¼" Spring Washer.
2	155/0414	¼" B.S.F. Socket Head Cap Screw, ⅜" long.
3	168X.103A	Pump End Plate.
4	168Y.101B	Pump Body.
5	168X.109A	Pump Gear Shaft.
6	—	Oil Seal No. 10016.
7	123/30	Woodruff Key.
8	209/6	Plug, ⅜" O.D. Tube.
9	218/19	Male Adaptor, ⅜" Tube.
10	168X.138A	Gear Pin.
11	168X.111A	Pump Gear.

List of Parts for
PLATE No. 56
(Drawing No. 168 Z 1B)

WHEN ORDERING SPARE PARTS ALWAYS QUOTE THE SERIAL NUMBER OF THE MACHINE

SWARF CHUTES

2¼"-6, 2¼"-6D, 2"-6 AND 2"-6D BAR MACHINES

6⅝"-6 AND 6⅝"-6D CHUCKING MACHINES

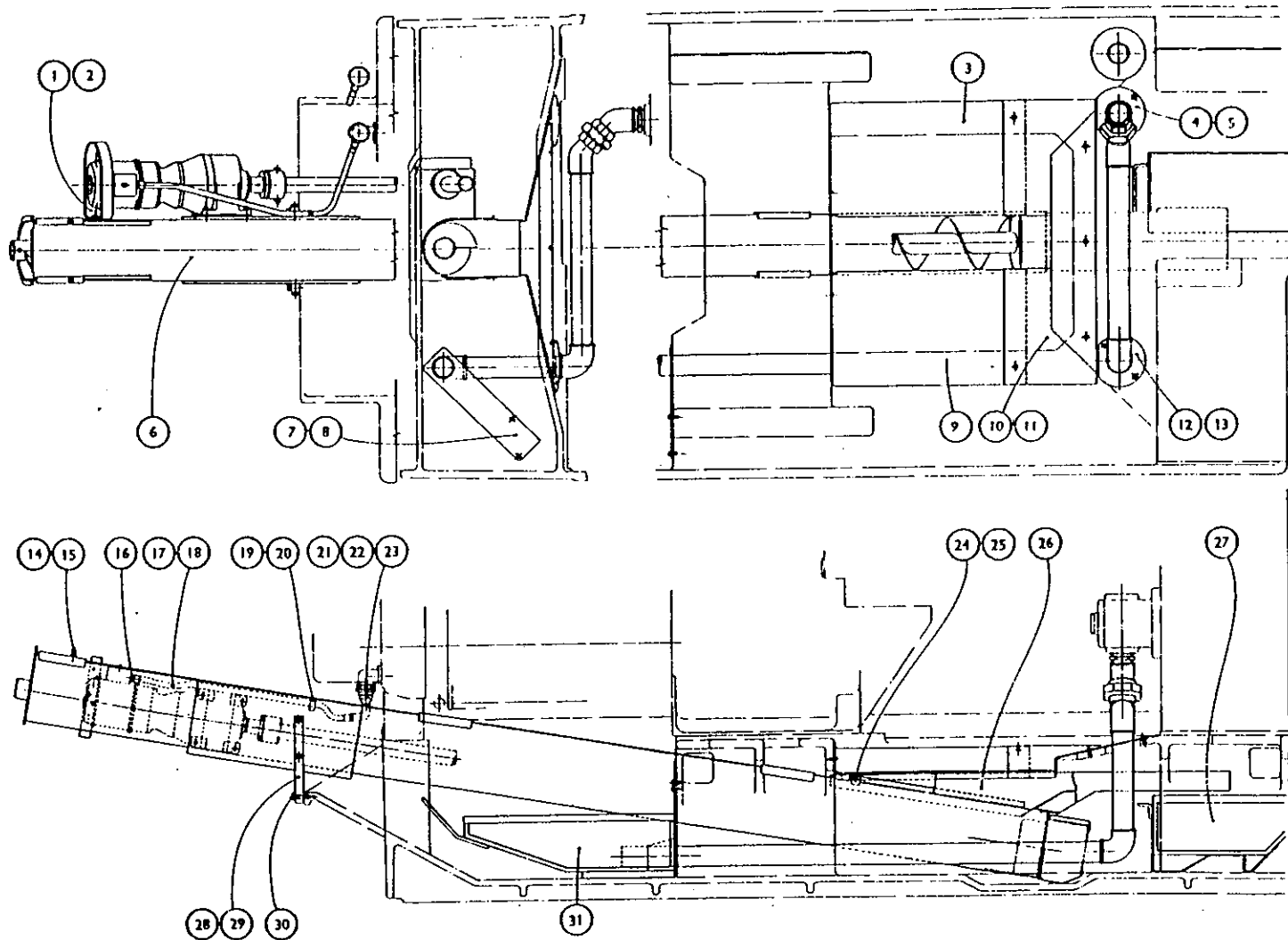

PLATE No. 55
(Drawing No. 363 Z1)

SWARF CHUTES

2¼"-6, 2¼"-6D BAR MACHINES

6¾"-6, 6¾"-6D CHUCKING MACHINES

INDEX NO.	PART NO.	TITLE
1	563V.151	Fender
2	167/0408	¼" BSF Hexagon Head Set Screw, ½" long
3	130/05	5/16" Flat Washer
4	166/0612	5/16" BSF Socket Head Cap Screw, ½" long
5	563Y.158A	Cover for Drive Tube
6	363V.136B	Swarf Chute - Rear
7	164/0510	5/16" BSF Round Head Screw, ¾" long
8	363Y.136B	Swarf Chute - Centre
9	363V.134B	Swarf Chute - Front
10	363Y.132	Trough Cover
11	203/04	¼" BSF Self Locking Nut
12	188/0412	¼" BSF Square Head Set Screw, ¾" long
13	357/13	13/16" Dowty Seal
14	563X.639	Conduit Adaptor
15	9351	90° Connector 20mm - ½" Conduit Thomas and Betts
16	347/1040B	¾" Conduit 40" long. Chucker machines only
17	347/1035	¾" Conduit 35" long. Bar machines only
18	156/210	2BA Socket Head Cap Screw, ½" long
19	DAS 186/12	¾" Dia. Dunlop Pipe Clip
20	357/13	13/16" Dowty Seal
21	9351	90° Connector 20mm - ½" Conduit. Thomas and Betts
22	SN400B	Niphan Threaded 20mm Female Plug
23	363Z133B	Swarf Chute
24	363V.155	Tray Weir
25	169Z.134A	Swarf Basket
26		Strainer Box etc. Section 369
27	163V.108	Support Plate
28	167/0612	¾" BSF Hexagon Head Set Screw, ¾" long
29		¾" Dia. large black Washer
30	170/0824	¼" BSF Hexagon Head Bolt, 1½" long
31	170/0624	¼" BSF Hexagon Head Bolt, 1½" long
32	163X.107A	Support Strip
33		Scrap view when 163X.107A is fitted

List of Parts for
 PLATE No.55A
 (Drawing No.363Z1C)

WHEN ORDERING SPARE PARTS ALWAYS QUOTE THE INSPECTION NUMBER OF THE MACHINE

SHARP CONVEYOR

2 1/4"-6, 2 1/4"-6D, 2"-6 AND 2"-6D BAR MACHINES. 6 1/4"-6 AND 6 1/4"-6D CHUCKING MACHINES

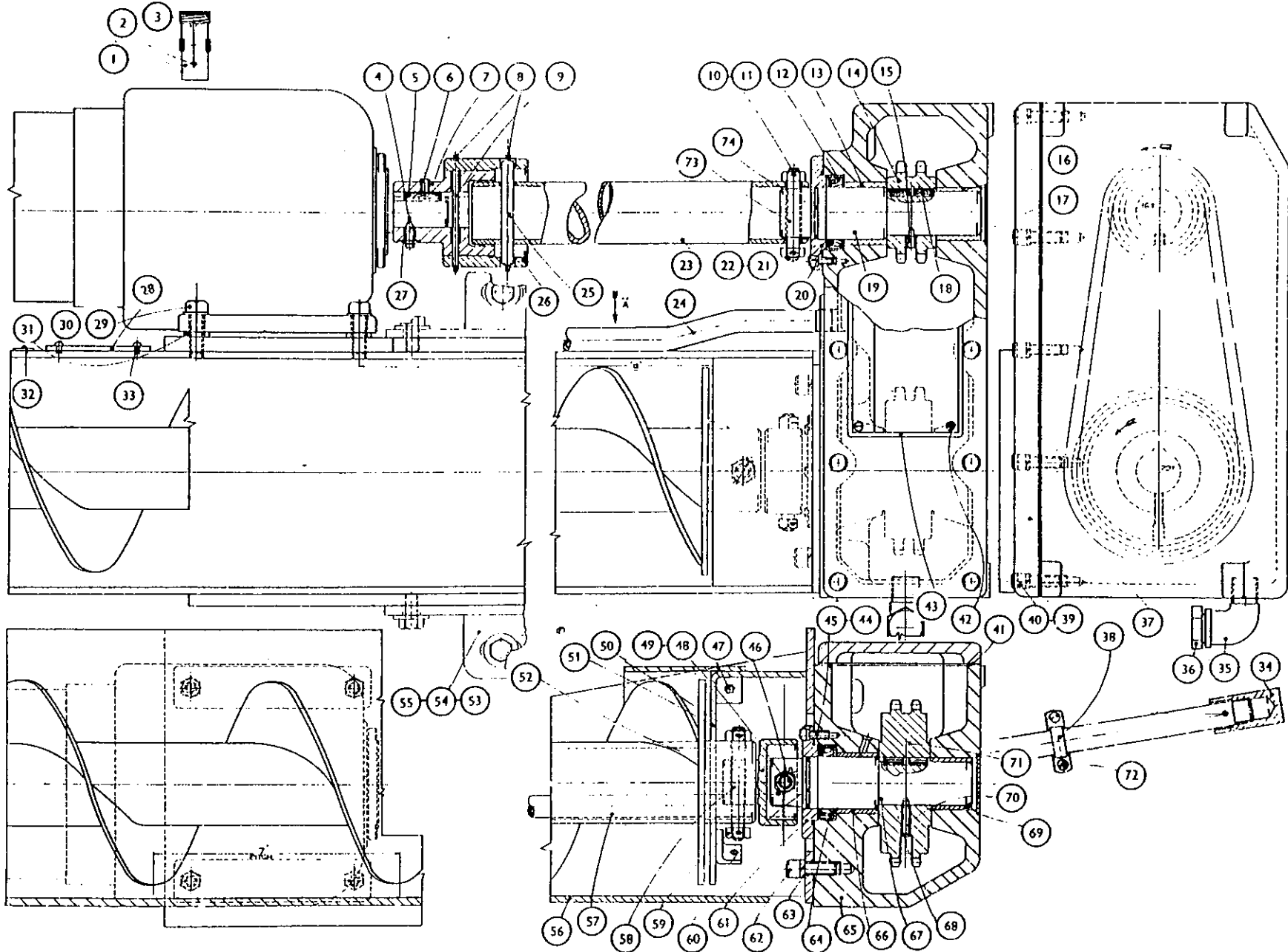

**WICKMAN
MULTI-SPINNLE
AUTOMATICS**

SWARF CHUTES

2 $\frac{1}{4}$ "-6, 2 $\frac{1}{4}$ "-6D, 2"-6 AND 2"-6D BAR MACHINES

6 $\frac{5}{8}$ "-6 AND 6 $\frac{5}{8}$ "-6D CHUCKING MACHINES

INDEX No.	PART No.	TITLE	INDEX No.	PART No.	TITLE
1	563V151	Fender	16	237/1210	Reducer $\frac{3}{4}$ " to $\frac{1}{2}$ " Conduit
2	167/0408	$\frac{1}{4}$ " B.S.F. Hexagon Head Set Screw, $\frac{1}{2}$ " long	17	Ref. 2	Superflexit Conduit — Chucker 40" L.
3	363V135	Swarf Chute — Rear	18	Ref. 2	Superflexit Conduit — Bar 35" L.
4	369X145	Core Cover	19	156/210	2 B.A. Socket Cap Screw, $\frac{3}{8}$ " long
5	164/0510	$\frac{1}{8}$ " B.S.F. Slotted Round Head Screw, $\frac{3}{4}$ " long	20	DAS185/12	$\frac{3}{4}$ " dia. Dunlop Pipe Clip
6	363Y132	Trough Cover	21	237/1210	Reducer $\frac{3}{4}$ " to $\frac{1}{2}$ " Conduit
7	155/0512	$\frac{1}{8}$ " B.S.F. Hexagon Socket Head Cap Screw, $\frac{3}{4}$ " long	22	237/83	Solid Elbow $\frac{3}{4}$ " Conduit
8	563X139A	Pipe Support	23	N400B	Niphan 4-pole 5 amp. Plug
9	363V134	Swarf Chute — Front	24	563X140	Clamp
10	363Y136	Swarf Chute — Centre	25	167/0406	$\frac{1}{4}$ " B.S.F. Hexagon Head Set Screw, $\frac{1}{2}$ " long
11	164/0510	$\frac{1}{8}$ " B.S.F. Slotted Round Head Screw, $\frac{3}{4}$ " long	26	363Y133	Swarf Chute
12	369X144	Suction Pipe Cover	27	169Z134A	Swarf Basket
13	164/0510	$\frac{1}{8}$ " B.S.F. Slotted Round Head Screw, $\frac{3}{4}$ " long	28	170/0624	$\frac{3}{8}$ " B.S.F. Hexagon Head Bolt, $1\frac{1}{2}$ " long
14	203/04	$\frac{1}{4}$ " B.S.F. Self Locking Nut	29	163X107A	Support Strip
15	188/0412	$\frac{1}{4}$ " B.S.F. Square Head Set Screw, $\frac{3}{4}$ " long	30	170/0824	$\frac{1}{2}$ " B.S.F. Hexagon Head Bolt, $1\frac{1}{2}$ " long
			31	563/138B	Coolant Strainer

List of Parts for
PLATE No. 55
(Drawing No. 363 Z1)

WHEN ORDERING SPARE PARTS ALWAYS QUOTE THE SERIAL NUMBER OF THE MACHINE

SWARF CONVEYOR

2¼"-6, 2½"-6D, 2"-6 AND 2"-6D BAR MACHINES

6⅝"-6 AND 6⅝"-6D CHUCKING MACHINES

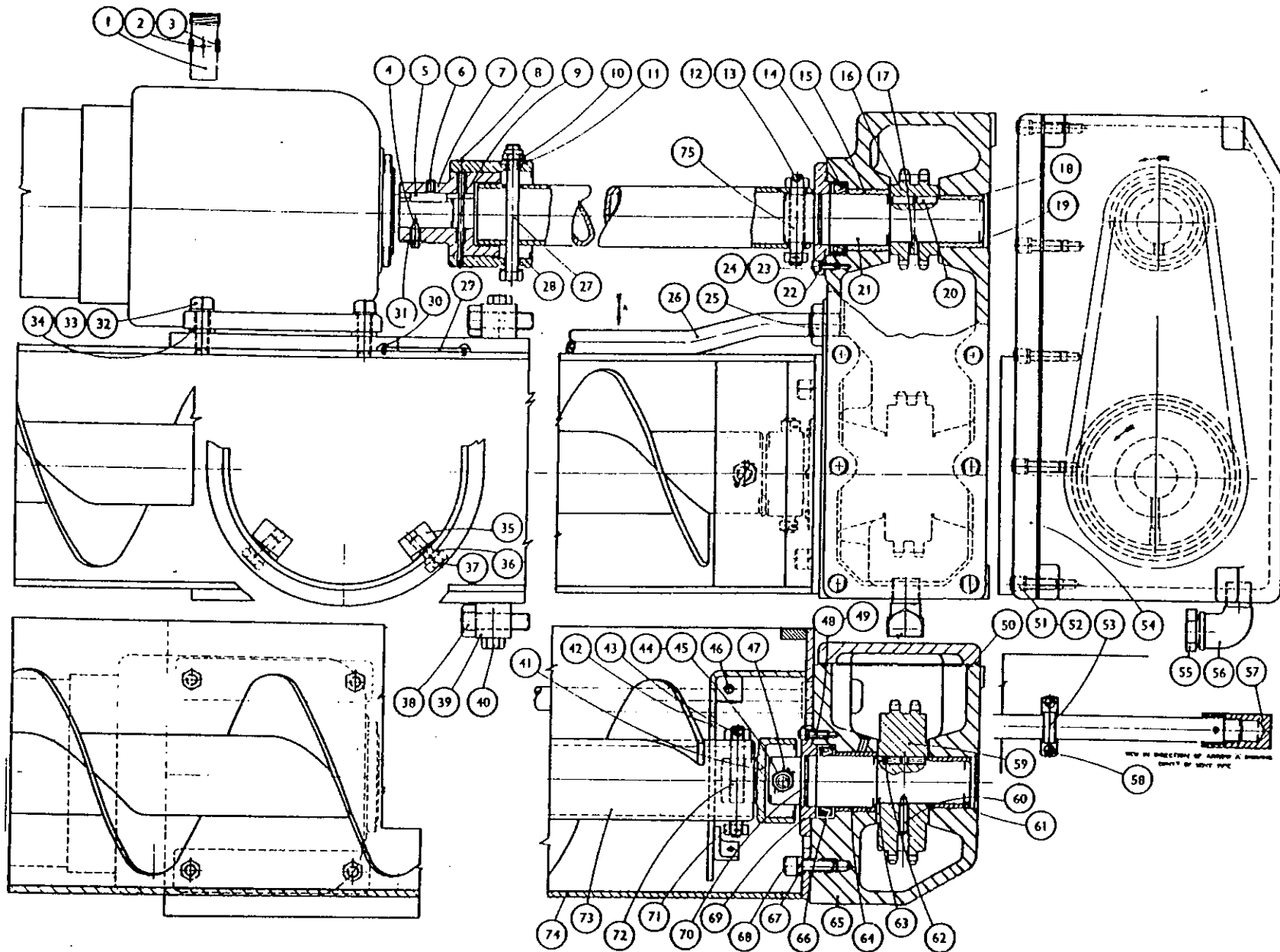

563 Z 1D SWARF CONVEYOR SECTION 563

2¼"- 6, 2¼"- 6D, 2"- 6 AND 2"- 6D BAR MACHINES

6½"- 6 AND 6½"- 6D CHUCKING MACHINES

INDEX NO.	PART NO.	TITLE	INDEX NO.	PART NO.	TITLE
1	FX7790	Container for Shear Pins	38	—	¾" Pipe Clip
2	162/404	4BA Counter Sunk Head Screw ¼" long	39	154/05	5/16" Spring Washer
3	—	¾" Terry Spring Clip for Container No.257	40	155/0516	6/16" BSF Socket Head Cap Screw 1" long
4	182/0412	¼" BSF Socket Set Screw, Taper Point, ¾" long	41	563Y.105	Gasket
5	122/0816	Square Key ¼" x 3/16" x 1" long	42	165/403	4BA Round Head Screw 3/16" long
6	179/206	2BA Socket Set Screw ¾" long	43	563X.154	Oiling Plate
7	563X.107D	Drive Coupling	44	154/2	2BA Spring Washer
8	355/815	80mm/in External Retaining Ring	45	156/208	2BA Socket Head Cap Screw ½" long
9	124/0644	5/32" Parallel Pin 2¾" long	46	563X.120	Drive Pin, Output
10	127/0607	3/32" Split Pin ¾" long	47	167/0408	¼" BSF Hexagon Head Set Screw ½" long
11	173/06	¾" BSF Hexagon Nut	48	127/0507	3/32" Split Pin ¾" long
12	235/24346	Oil Seal	49	173/06	¾" BSF Hexagon Nut
13	236/242820	Oil Retaining Bush	50	127/0607	3/32" Split Pin ¾" long
14	563X.149	Pinion, 16T	51	563V.146B	Cover Plate
15	182/0408	¼" BSF Socket Set Screw, Taper Point, ½" long	52	563X.115	Drive Coupling
16	236/202420	Oil Retaining Bush	53	167/0612	¾" BSF Hexagon Head Set Screw ¾" long
17	129/24	1¾" Welch Plug	54	163V.108	Support Strip
18	122/1020T	5/16" Tapped Key 1¼" long	55	—	¾" Large Block Washer
19	563X.113	Sprocket Shaft	56	563Z.102H	Swarf Trough
20	563X.111	End Plate	57	563Y.103C	Swarf Screw
21	156/208	2BA Socket Head Cap Screw ½" long	58	563X.118	Drive Pin, Screw
22	154/2	2BA Spring Washer	59	173/06	¾" BSF Hexagon Nut
23	563X.106C	Drive Tube	60	563X.114	Piston Ring Seal
24	563X.116A	Vent Pipe	61	563X.111	End Plate
25	563X.145A	Drive Pin, Coupling	62	155/0616	¾" BSF Socket Head Cap Screw 1" long
26	563X.126B	Drive Sleeve	63	154/06	¾" Spring Washer
27	173/04L	¼" BSF Hexagon Locknut	64	235/24346	Oil Seal
28	563X.144B	Instruction Plate	65	563Z.101A	Drive Housing
29	167/0516	5/16" BSF Hexagon Head Set Screw 1" long	66	236/242820	Oil Retaining Bush
30	130/05	5/16" Flat Washer	67	563X.113	Sprocket Shaft
31	563X.132	Spacer	68	122/1020T	5/16" Tapped Key 1¼" long
32	291/71	Legend Plate	69	236/202420	Oil Retaining Bush
33	165/403	4BA Round Head Screw 3/16" long	70	182/0416	¼" BSF Socket Set Screw, Taper Point, 1" long
34	563X.117	Cap	71	563X.150	Chain Wheel 29T
35	—	½" BSP 90° Elbow Male & Female	72	165/206	2BA Round Head Screw ¾" long
36	—	½" BSP Hexagon Pipe Plug	73	563X.119	Drive Pin, Input
37	563Y.104	Cover for Housing	74	563X.114	Piston Ring Seal

List of Parts for
Plate No.54A
(Drawing No.563Z1D)

WHEN ORDERING SPARE PARTS ALWAYS QUOTE THE INSPECTION NUMBER OF THE MACHINE

2 1/4"-6, 2 1/4"-6D, 2"-6 AND 2"-6D BAR MACHINES
 6 5/8"-6 AND 6 5/8"-6D CHUCKING MACHINES

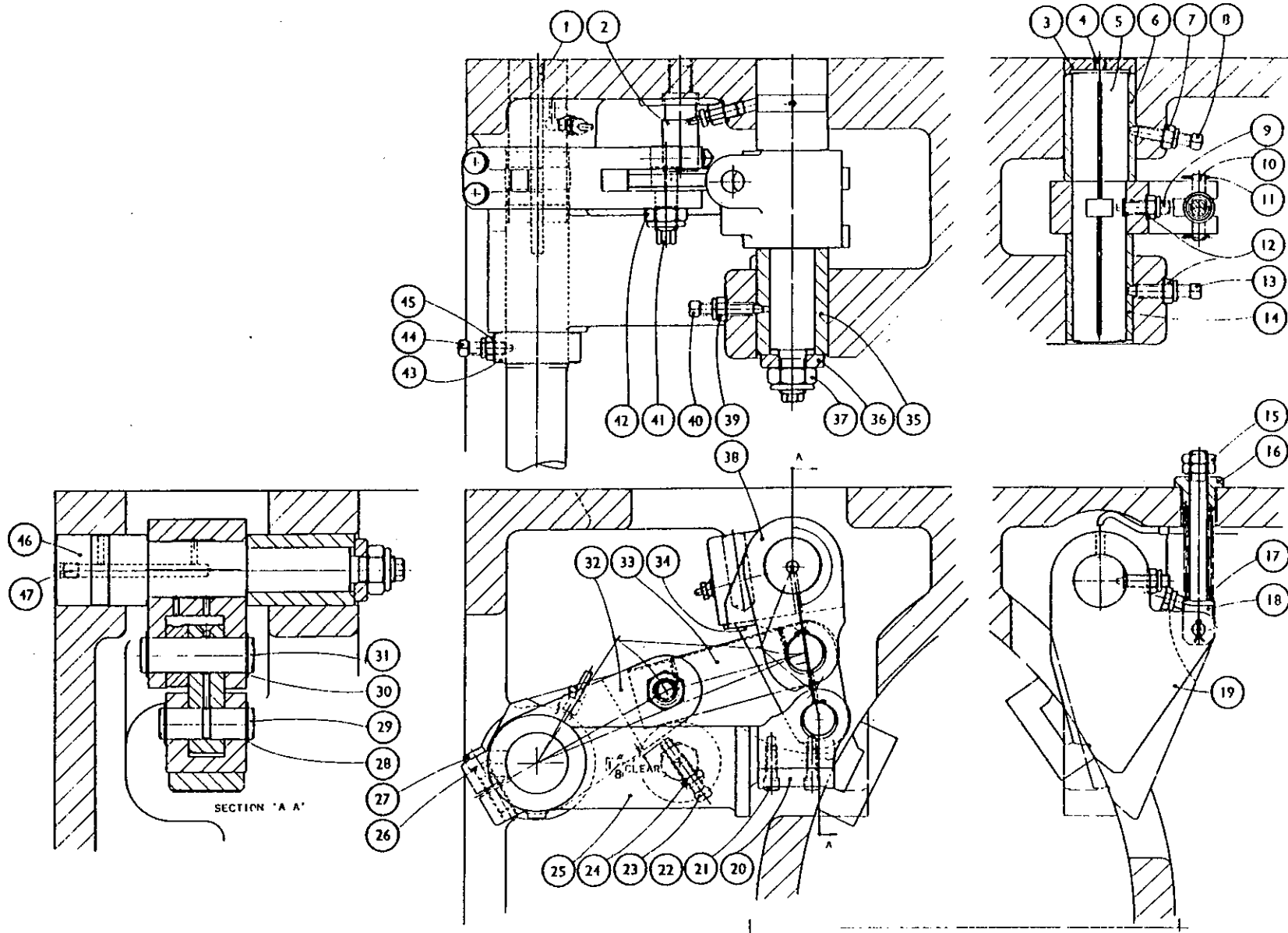

List of Parts for
 PLATE No. 53
 (Drawing No. 361 Z 1)

**WICKMAN
MULTI-SPINDLE
AUTOMATICS**

SWARF CONVEYOR

2¼"-6, 2¼"-6D, 2"-6 AND 2"-6D BAR MACHINES

6½"-6 AND 6½"-6D CHUCKING MACHINES

INDEX NO.	PART NO.	TITLE.	INDEX NO.	PART NO.	TITLE.
1	FX.7790	Container, for Shear Pins.	39	163X.107	Support Strip.
2	165/403	4 B.A. Round Head Screw, ⅝" long.	40	170/0624	⅜" B.S.F. Hexagon Head Bolt, 1½" long.
3	—	⅜" dia. Spring Clip for Container.	41	563X.115	Coupling, Driven.
4	182/0412	⅜" B.S.F. Socket Set Screw, Taper Point, ⅜" long.	42	563X.146	Cover Plate.
5	122/0816SQ	Square Key, ¼" × ⅜" × 1" long.	43	127/0607	⅜" dia. Split Pin, ⅜" long.
6	179/206	2 B.A. Socket Set Screw, ⅜" long.	44	173/06	⅜" B.S.F. Hexagon Nut.
7	563X.107C	Coupling, Driving.	45	127/0607	⅜" dia. Split Pin, ⅜" long.
8	563X.127	Spring Ring.	46	167/0408	⅜" B.S.F. Hexagon Head Set Screw, ⅜" long.
9	124/0444	⅜" dia. Silver Steel Pin, 2¼" long.	47	563X.120	Drive Pin, Output.
10	203/05L	⅜" B.S.F. Self-Locking Locknut.	48	156/208	2 B.A. Socket Head Cap Screw, ⅜" long.
11	130/05	⅜" dia. Plain Washer.	49	154/2	2 B.A. Spring Washer.
12	127/0607	⅜" dia. Split Pin, ⅜" long.	50	563Y.105	Gasket.
13	173/06	⅜" B.S.F. Hexagon Nut.	51	155/0516	⅜" B.S.F. Socket Head Cap Screw, 1" long.
14	235/24346	Oil Seal.	52	154/05	⅜" Spring Washer.
15	236/242820	Oil Retaining Bush.	53	GF.FIG.860	⅜" B.S.P. Pipe Clip.
16	563X.149	Pinion, 16T.	54	563Y.104	Cover for Housing.
17	182/0408	⅜" B.S.F. Socket Set Screw, Taper Point, ⅜" long.	55	GF.FIG.292	⅜" B.S.P. Hexagon Pipe Clip.
18	236/202420	Oil Retaining Bush.	56	—	⅜" B.S.P. 90° Elbow, M. & F.
19	129/24	1½" dia. Welch Plug.	57	563X.117	Cap.
20	122/1020T	⅜" dia. Tapped Key, 1¼" long.	58	165/206	2 B.A. Round Head Screw, ⅜" long.
21	563X.113	Sprocket Shaft.	59	563X.150	Chain Wheel, 29T.
22	563X.111	End Plate.	60	182/0416	⅜" B.S.F. Socket Set Screw, Taper Point, 1" long.
23	156/208	2 B.A. Socket Head Cap Screw, ⅜" long.	61	236/202420	Oil Retaining Bush.
24	154/2	2 B.A. Spring Washer.	62	122/1020T	⅜" dia. Tapped Key, 1¼" long.
25	224/3	⅜" B.S.P. Locknut.	63	563X.113	Sprocket Shaft.
26	563X.116	Vent Pipe.	64	263/242820	Oil Retaining Bush.
27	563X.145	Drive Pin, Coupling.	65	563Z.101A	Drive Housing.
28	563X.126A	Drive Sleeve.	66	235/24346	Oil Seal.
29	563X.144A	Instruction Plate.	67	154/06	⅜" Spring Washer.
30	165/403	4 B.A. Round Head Screw, ⅝" long.	68	155/0616	⅜" B.S.F. Socket Head Cap Screw, 1" long.
31	173/04L	⅜" B.S.F. Hexagon Locknut.	69	563X.111	End Plate.
32	170/0616	⅜" B.S.F. Hexagon Head Bolt, 1" long.	70	563X.114	Piston Ring Seal.
33	130/06	Plain Washer.	71	173/06	⅜" B.S.F. Hexagon Nut.
34	SM97/20	Spacer.	72	563X.118	Drive Pin, Screw.
35	563X.128	Support Strip.	73	563Y.103A	Swarf Screw.
36	154/06	⅜" Spring Washer.	74	563Z.102C	Swarf Trough.
37	167/0612	⅜" B.S.F. Hexagon Head Set Screw, ⅜" long.	75	563X.119	Drive Pin, Input.
38	170/0824	⅜" B.S.F. Hexagon Head Bolt, 1½" long.			

List of Parts for
PLATE No. 54
(Drawing No. 563 Z IC)

WHEN ORDERING SPARE PARTS ALWAYS QUOTE THE SERIAL NUMBER OF THE MACHINE

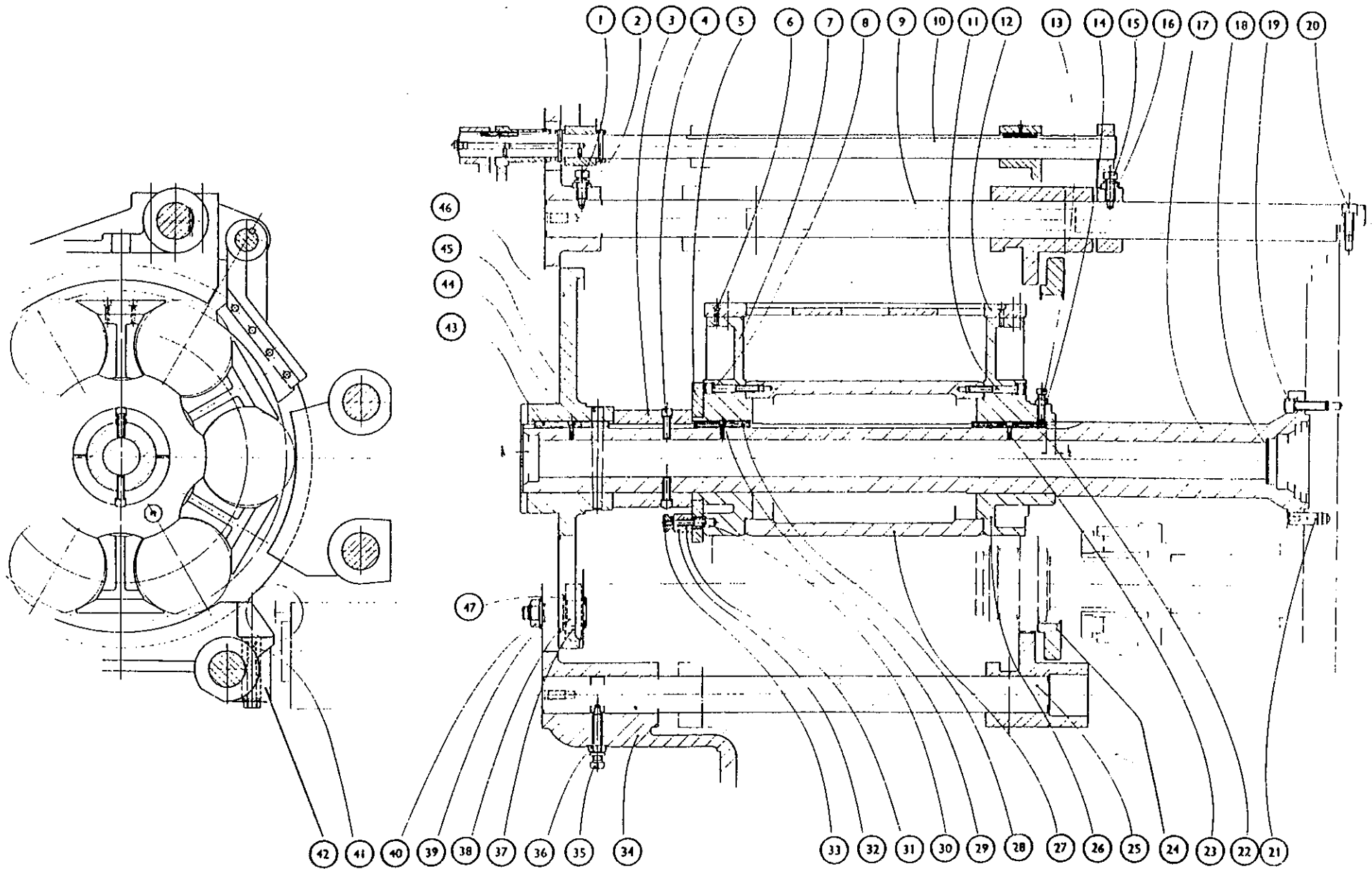

2"-6L LONG BAR FEED AUTO.
 FEED TUBE GUIDES AND AUTO STOP. 360 Z 2

LIST of PARTS for
 PLATE No. 52
 (Drawing No. 360 Z 2)

**WICKMAN
MULTI-SPINDLE
AUTOMATICS**

DRUM LOCKING

2¼"-6, 2¼"-6D, 2"-6 AND 2"-6D BAR MACHINES
6⅝"-6 AND 6⅝"-6D CHUCKING MACHINES

INDEX NO.	PART NO.	TITLE.	INDEX NO.	PART NO.	TITLE.
1	194/1	½" B.S.P. Pipe Plug.	24	203/06L	½" B.S.F. Self-Locking Nut (Thin).
2	361X.149	Stop Anchor.	25	361Y.104	Lower Toggle Lever.
3	361X.137	Plug for Drum Locking.	26	154/07	⅝" Spring Washer.
4	176/0505	⅝" B.S.F. Socket Set Screw, Cup Point, ⅝" long.	27	155/0724	⅝" B.S.F. Socket Head Cap Screw, 1½" long.
5	561X.109	Latch Fin.	28	101/7	⅝" External Circlip.
6	561X.111A	Bush for Drum Latch Pin.	29	361X.125	Pin.
7	203/06	½" B.S.F. Self-Locking Nut.	30	101/11	1" External Circlip.
8	183/0628	½" B.S.F. Square Head Set Screw, Taper Point, 1½" long.	31	361X.123	Pin.
9	182/0624	½" B.S.F. Socket Set Screw, Taper Point, 1½" long.	32	361V.103	Operating Lever.
10	561X.142	Pin.	33	361X.146	Operating Link.
11	127/0406	⅝" dia. Split Cotter Pin, ½" long.	34	361X.105	Toggle lever.
12	203/06	½" B.S.F. Self-Locking Nut.	35	561X.130B	Locking Sleeve.
13	183/0628	½" B.S.F. Square Head Set Screw, Taper Point, 1½" long.	36	561X.129	Locking Washer.
14	561X.110	Bush for Drum Latch Pin.	37	203/12L	½" B.S.F. Self-Locking Nut (Thin).
15	173/08L	½" B.S.F. Hexagon Locknut.	38	361V.102	Toggle Lever.
16	561X.114A	Spring Retaining Plug.	39	203/06	½" B.S.F. Self-Locking Nut.
17	561X.113	Spring for Drum Latch.	40	183/0628	½" B.S.F. Square Head Set Screw, Taper Point, 1½" long.
18	561X.141	Retaining Rod.	41	361X.151	Eccentric Pin.
19	361V.108	Drum Latch.	42	203/10L	½" B.S.F. Self-Locking Nut (Thin).
20	361X.131	Drum Locking Pad.	43	361X.150	Collar.
21	155/0514	⅝" B.S.F. Socket Head Cap Screw, ¾" long.	44	183/0620	½" B.S.F. Square Head Set Screw, Taper Point, 1½" long.
22	154/05	⅝" Spring Washer.	45	203/06	½" B.S.F. Self-Locking Nut.
23	188/0628	½" B.S.F. Square Head Set Screw, 1½" long.	46	361V.128	Toggle Lever Eccentric Shaft.
			47	194/1	½" B.S.P. Socket Pipe Plug.

List of Parts for
PLATE No. 53
(Drawing No. 361 Z 1)

WHEN ORDERING SPARE PARTS ALWAYS QUOTE THE SERIAL NUMBER OF THE MACHINE

LONG BAR FEED

2½"-6 BAR MACHINES

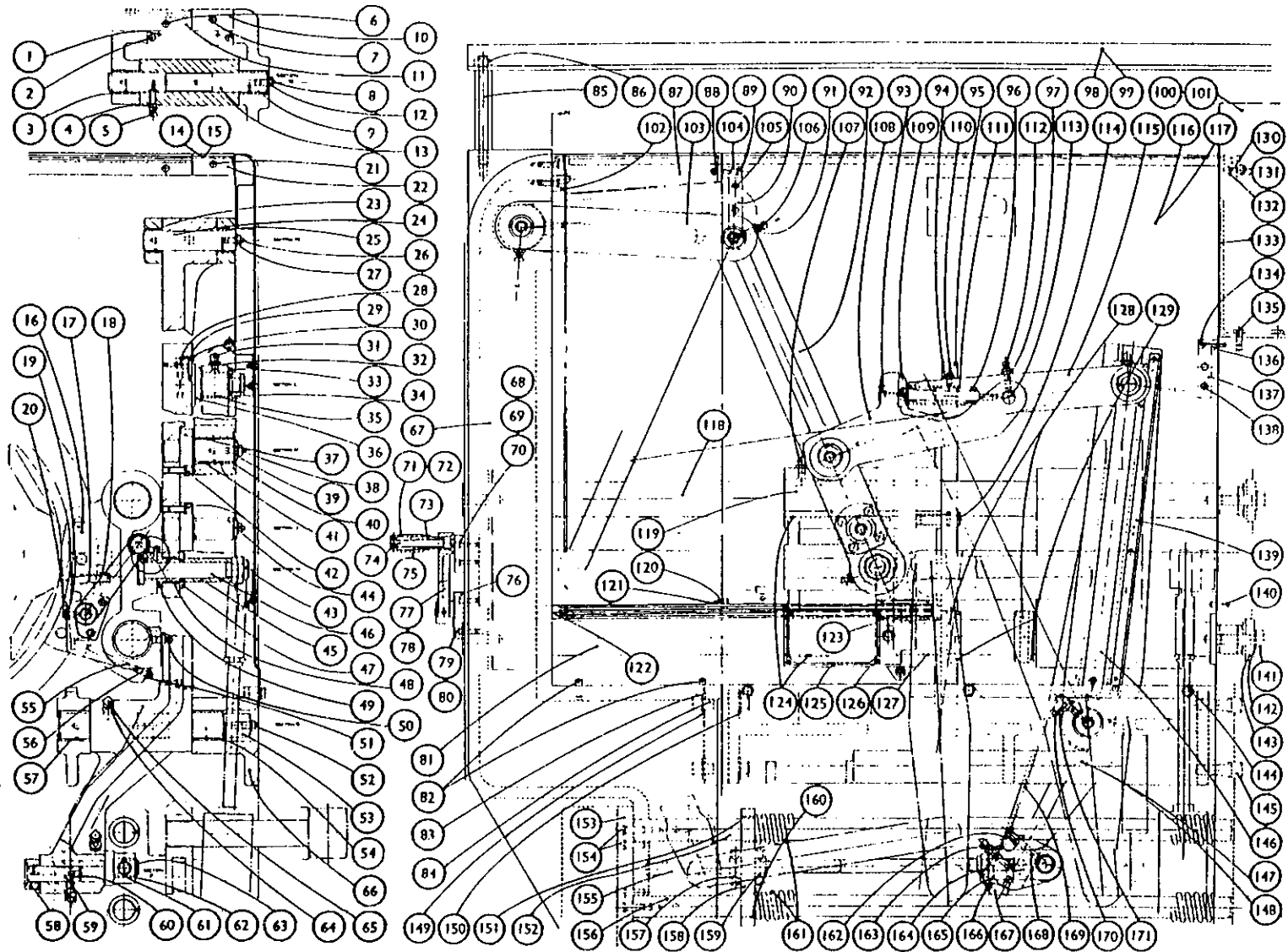

**WICKMAN
MULTI-SPINDLE
AUTOMATICS**

**LONG BAR FEED
2¼"-6 AND 2"-6 CHUCKING MACHINES**

INDEX NO.	PART NO.	TITLE.	INDEX NO.	PART NO.	TITLE.
1	183/0824	½" B.S.F. Square Head Set Screw, 1½" long.	22	301X.172	Key.
2	203/08L	½" B.S.F. Self-Locking Nut.	23	156/210	2 B.A. Socket Head Cap Screw, ½" long.
3	360X.122	Half Collar.	24	358Z.158	Thrust Ring.
4	155/0620 154/06	¾" B.S.F. Socket Head Cap Screw, 1½" long. ¾" Spring Washer.	25	360X.126	Lower Guide Bar.
5	301Y.169	Stop Plate.	26	360Z.114	Front Spider.
6	155/0416 154/04	½" B.S.F. Socket Head Cap Screw, 1" long. ½" Spring Washer.	27	360Y.116	Cylindrical Guide.
7	360Z.115	Rear Spider.	28	360X.124	Key.
8	155/0640 154/06	¾" B.S.F. Socket Head Cap Screw, 2½" long. ¾" Spring Washer.	29	156/210	2 B.A. Socket Head Cap Screw, ½" long.
9	360Y.125	Upper Guide Bar.	30	577X.125	Plunger.
10	360V.127	Trip Shaft.	31	558X.128	Spring.
11	155/0640 154/06	¾" B.S.F. Socket Head Cap Screw, 2½" long. ¾" Spring Washer.	32	558X.123A	Fulcrum Pin.
12	360Y.117	Outer Guide.	33	577X.126	Knob.
13	188/0620	½" B.S.F. Square Head Set Screw, 1½" long.	34	360Z.102	End Bracket.
14	203/06L	¾" B.S.F. Self-Locking Nut.	35	183/0848	½" B.S.F. Square Head Set Screw, Taper Point, 3" long.
15	183/0624	½" B.S.F. Square Head Set Screw, Taper Point, 1½" long.	36	203/08L	¾" B.S.F. Self-Locking Nut.
16	203/06L	¾" B.S.F. Self-Locking Nut.	37	358X.115	Roller.
17	360Z.120	Drive Coupling.	38	358X.164	Eccentric Roller Pin.
18	129/29	2½" dia. Welch Plug.	39	130/14	¾" Flat Washer.
19	155/0828 154/08	½" B.S.F. Socket Head Cap Screw, 1½" long. ½" Spring Washer.	40	173/14LH	¾" B.S.F. Hexagon Locknut.
20	155/0820 154/08	½" B.S.F. Socket Head Cap Screw, 1½" long. ½" Spring Washer.	41	360X.129	Lower Bolt.
21	301X.173	Parallel Pin.	42	360X.128	Modification to Aligning Plate Carrier.
			43	210/2525	Yellow Indicator Washer.
			44	212/03GS	½" B.S.P. Oil Nipple.
			45	301X.172	Key.
			46	156/210	2 B.A. Socket Head Cap Screw, ½" long.
			47	125/4088	¾" Taper Pin, 5½" long.
			48	358Z.150	Driving Disc.

List of Parts for
PLATE No. 52
(Drawing 360 Z 2)

WHEN ORDERING SPARE PARTS ALWAYS QUOTE THE SERIAL NUMBER OF THE MACHINE

LONG BAR FEED
2 1/4"-6 AND 2"-6 BAR MACHINES

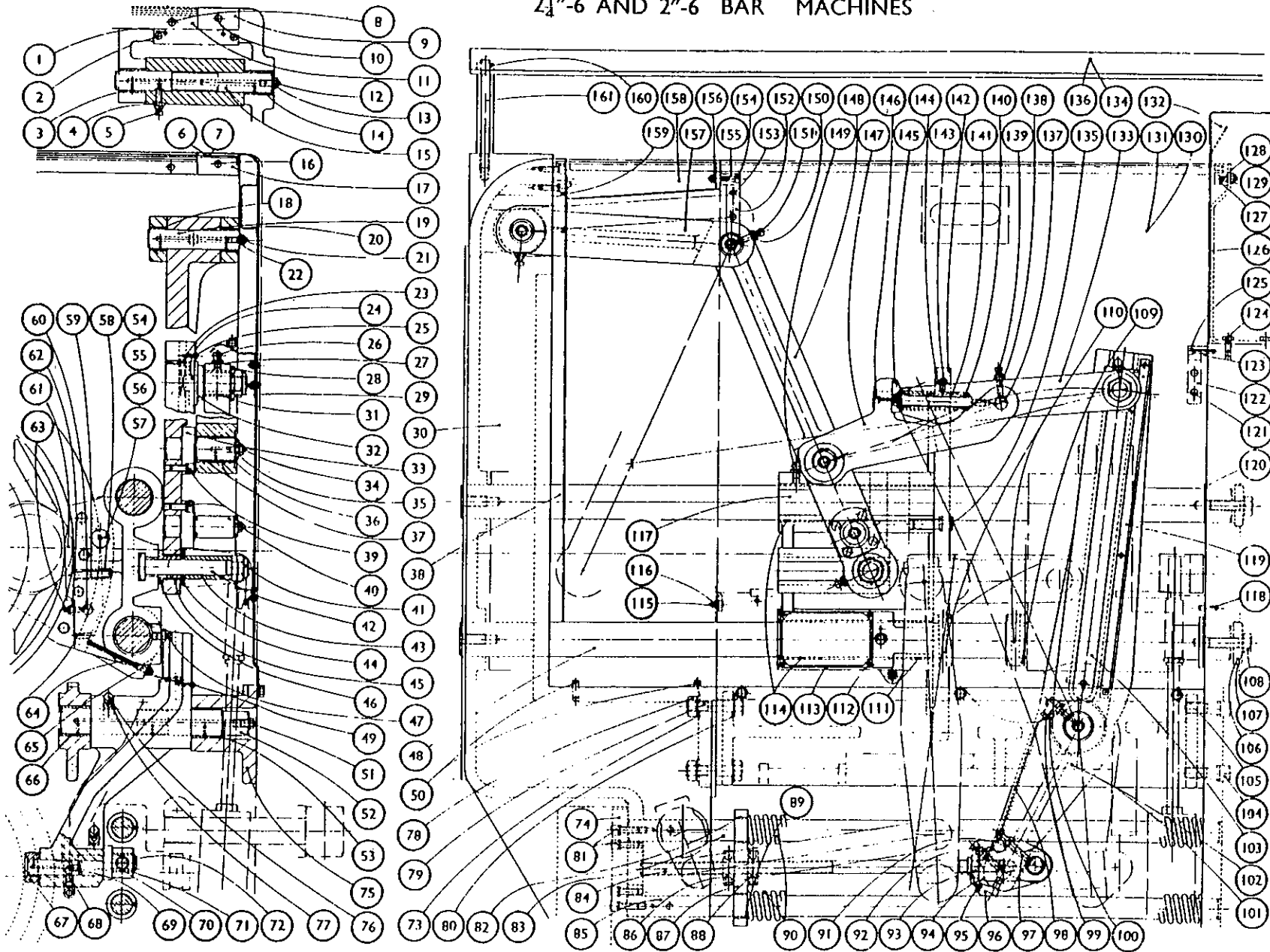

PLATE No. 51
(Drawing No. 360 Z 1)

**WICKMAN
MULTI-SPINDLE
AUTOMATICS**

LONG BAR FEED

2 1/4" — 6 BAR MACHINES

INDEX NO.	PART NO.	TITLE	INDEX NO.	PART NO.	TITLE	INDEX NO.	PART NO.	TITLE
1	155/0410	1/2" B.S.F. Socket Head Cap Screw 1/2" long.	58	358X.112	Cam Roller.	118	360X.107A	Guide Bar.
	154/04	Spring Washer.	59	358X.107	Roller Pin.	119	360Z.101A	Bar Feed Slide.
2	155/0516	3/4" B.S.F. Socket Head Cap Screw 1" long.	60	194/1	1/2" B.S.P. Socket Pipe Plug.	120	203/2	2 B.A. Self Locking Hexagon Nut.
	154/05	Spring Washer.	61	236/141820	Oil Retaining Bush.	121	156/208	2 B.A. Socket Head Cap Screw 1 1/2" long.
3	236/182216	Oil Retaining Bush.	62	101/9	External Circlip.	122	360X.130	Splined Bush.
4	203/05L	1/2" B.S.F. Self Locking Hexagon Locknut.	63	360X.121	Link Pin.	123	158X.140	Splined Bush.
5	182/0524	3/4" B.S.F. Socket Set Screw Taper Point 1 1/4" long.	64	203/06L	1/2" B.S.F. Self Locking Hexagon Locknut.	124	236/323640	Oil Retaining Bush.
6	155/0516	3/4" B.S.F. Socket Head Cap Screw 1" long.	65	183/0624	1/2" B.S.F. Square Head Set Screw Taper Point. 1 1/4" long.	125	360X.136	Instruction Plate.
7	155/0516	3/4" B.S.F. Socket Head Cap Screw 1" long.	66	358Z.103A	Connecting Bridge.	126	165/406	4 B.A. Round Head Screw 1/2" long.
8	212/03G5	Grease Nipple (Long).	67	360Z.102A	End Bracket.	127	236/323640	Oil Retaining Bush.
9	236/182216	Oil Retaining Bush.	68	158X.177A	Plate.	128	125/3248	Taper Pin 1/4" dia. 3" long.
10	322X.179	Top Cover Stop.	69	155/0416	1/2" B.S.F. Socket Head Cap Screw 1" long.	129	358X.162	Stop Collar.
11	322X.165	Top Cover Guide.	70	154/04	Spring Washer.	130	155/0516	1/2" B.S.F. Socket Head Cap Screw 1" long.
12	210/2525	Yellow Indicator Washer.	71	158X.156	Plunger Knob.	131	203/05L	1/2" B.S.F. Self Locking Nut.
13	360X.110	Pivot Pin.	72	125/0816	Taper Pin.	132	322X.165	Top Cover Guide.
14	360Y.144	Top Cover (Front).	73	MSC.155	Spring.	133	360V.140	Guide Bracket.
15	360Y.144	Top Cover (Rear).	74	158X.159	Plunger.	134	155/0420	1/2" B.S.F. Socket Head Cap Screw 1 1/2" long.
16	358V.105A	Pusher Plate.	75	158X.154	Spring Housing.	135	167/0516	1/2" B.S.F. Bright Hexagon Head Set Screw 1" long.
17	558X.129B	Spring.	76	358X.133	Bearing Block.	136	122X.204	Latch Post.
18	558X.124A	Spring Plunger.	77	158X.132B	Lever.	137	122X.116	Spring Catch.
19	203/06L	1/2" B.S.F. Self Locking Hexagon Nut.	78	125/1620	Taper Pin 1/2" dia. 1 1/2" long.		164/0408	1/2" B.S.F. Round Head Set Screw 1/2" long.
20	182/0614	3/4" B.S.F. Socket Set Screw Taper Point 1/2" long.	79	155/0516	1/2" B.S.F. Socket Head Cap Screw 1" long.	138	203/04	1/2" B.S.F. Self Locking Hexagon Nut.
21	155/0516	3/4" B.S.F. Socket Head Cap Screw 1" long.	80	154/05	Spring Washer.	139	360Y.109	Scale.
22	322X.179	Top Cover Stop.	81	360X.107A	Guide Bar.	140	143/1016D	Grooved Pin 3/8" dia. 1" long.
23	236/182216	Oil Retaining Bush.	82	143/1016D	Grooved Pin 3/8" dia. x 1" long.	141	167/1032	1/2" B.S.F. Hexagon Head Set Screw 2" long.
24	360X.111	Pivot Pin.	83	173/10	1/2" B.S.F. Hexagon Nut.	142	198/1B	Internal Shakeproof Washer.
25	236/182216	Oil Retaining Bush.	84	170/1044	1/2" B.S.F. Hexagon Head Bolt 2 1/2" long.	143	358X.117	Guide Washer.
26	212/03G5	Grease Nipple (Long).	85	360X.152	Rail Support	144	167/0512	1/2" B.S.F. Bright Hexagon Head Set Screw 1/2" long.
27	210/2525	Yellow Indicator Washer.	86	173/08	1/2" B.S.F. Hexagon Nut.		130/05	1/2" Washer.
28	155/0410	1/2" B.S.F. Socket Head Cap Screw 1/2" long.	87	360Y.147	Fixed Cover.	145	155/1032	1/2" B.S.F. Socket Head Cap Screw 2" long.
	154/04	Spring Washer.	88	203/04	1/2" B.S.F. Self Locking Nut		154/10	Spring Washer.
29	358X.108	Pivot Pin	89	155/0424	1/2" B.S.F. Socket Head Cap Screw 1 1/2" long.	146	360Z.104A	Bar Feed Lever.
30	165/206	2 B.A. Round Head Screw 1/2" long.	90	122X.116	Spring Catch.	147	358Z.171	Bar Feed Cam (Forward).
31	212/4518	Grease Nipple.	91	203/05L	1/2" B.S.F. Self Locking Hexagon Locknut.	148	358Z.172	Bar Feed Cam (Return).
32	210/2525	Yellow Indicator Washer.	92	360Y.105A	Operating Lever.	149	198/1B	Internal Shakeproof Washer.
33	341X.116	Slotted Washer.	93	155/0416	1/2" B.S.F. Socket Head Cap Screw 1" long.	150	130/1C	Plain Washer.
34	203/14L	1/2" B.S.F. Self Locking Hexagon Locknut.	94	203/05L	1/2" B.S.F. Self Locking Hexagon Locknut.	151	CT.685	Oil Retaining Bush
35	236/202424	Oil Retaining Bush.	95	358Z.158A	Thrust Ring.	152	358X.152	Spring Guide.
36	360V.118	Link Pivot.	96	360X.153	Spring — Safety Link	153	358X.155	Retaining Plate.
37	360X.113A	Link Pivot.	97	203/05L	1/2" B.S.F. Self Locking Hexagon Locknut.	154	155/0620	1/2" B.S.F. Socket Head Cap Screw 1 1/2" long.
38	212/03G5	Grease Nipple (Long).	98	360X.150	Guard Rail — Front.		154/06	1/2" Spring Washer.
39	210/2525	Yellow Indicator Washer.	99	360X.151	Guard Rail — Rear.	155	358X.151	Spring Stud.
40	101/15	External Circlip.	100	360V.145A	Cover.	156	358X.152	Spring Guide.
41	236/202416	Oil Retaining Bush.	101	360V.149	Cover.	157	358X.120A	Locknut.
42	155/0616	1/2" B.S.F. Socket Head Cap Screw 1" long.	102	360X.148	Support Block.	158	358X.153	Pressure Plate.
43	203/14	1/2" B.S.F. Self Locking Hexagon Nut.	103	360Y.106	Fulcrum Lever.	159	358X.120A	Locknut.
44	360X.113A	Link Pivot.	104	122X.204	Latch Post.	160	CT.685	Oil Retaining Bush
45	360X.119	Sleeve.	105	164/0408	1/2" B.S.F. Round Head Set Screw 1/2" long.	161	350X.161 or	Spring.
46	360X.108	Pivot Bolt.		203/04	1/2" B.S.F. Self Locking Nut.		360X.155	Spring.
47	341X.116	Slotted Washer.	106	183/0524	1/2" B.S.F. Socket Set Screw Taper Point 1 1/4" long.	162	203/06L	1/2" B.S.F. Self Locking Nut.
48	236/202416	Oil Retaining Bush.	107	212/4518	Grease Nipple 45°	163	183/0632	1/2" B.S.F. Square Head Set Screw Taper Point 2" long.
49	360X.112	Lever Pivot.		210/2525	Yellow Indicator Washer.	164	203/12L	1/2" B.S.F. Self Locking Nut.
50	212/4518	Grease Nipple 45°.	108	360Y.103A	Link Body.	165	358X.165	Connecting Block.
	210/2525	Yellow Indicator Washer.	109	358X.169	Plunger Seating.	166	14.07.04	4mm Tubing Nut
51	203/05L	1/2" B.S.F. Self Locking Hexagon Locknut.	110	182/0514	1/2" B.S.F. Socket Set Screw Taper Point 1/2" long.	167	14.75.0402	4mm Tubing Sleeve
52	212/03G5	Grease Nipple (Long).	111	358X.168	Plunger.	168	183/0640	1/2" B.S.F. Square Head Set Screw 2 1/2" long
	210/2525	Yellow Indicator Washer.	112	183/0528	1/2" B.S.F. Square Head Set Screw Taper Point 1 1/4" long.	169	14.02.406	4mm Copper Tube 16ft long
53	356V.109	Pivot Shaft.	113	358X.167	Pin.	170	14.07.04	4mm Tubing Nut
54	236/242828	Oil Retaining Bush.	114	155/1024	1/2" B.S.F. Socket Head Cap Screw 1 1/4" long.	171	14.07.04	4mm Tubing Nut
55	360X.123	Stop Pin.	115	358V.119	Link		14.08.04	4mm Tubing Sleeve
56	178/0516	1/2" B.S.F. Socket Set Screw Half Dog. 1" long.	116	340Y.146	Hinge Cover Bracket (Front).			
57	236/242828	Oil Retaining Bush.	117	360Y.143	Hinge Cover Bracket (Rear).			

List of Parts for
PLATE No. 51A
(Drawing No. 360Z1A)

WHEN ORDERING SPARE PARTS ALWAYS QUOTE THE SERIAL NUMBER OF THE MACHINE

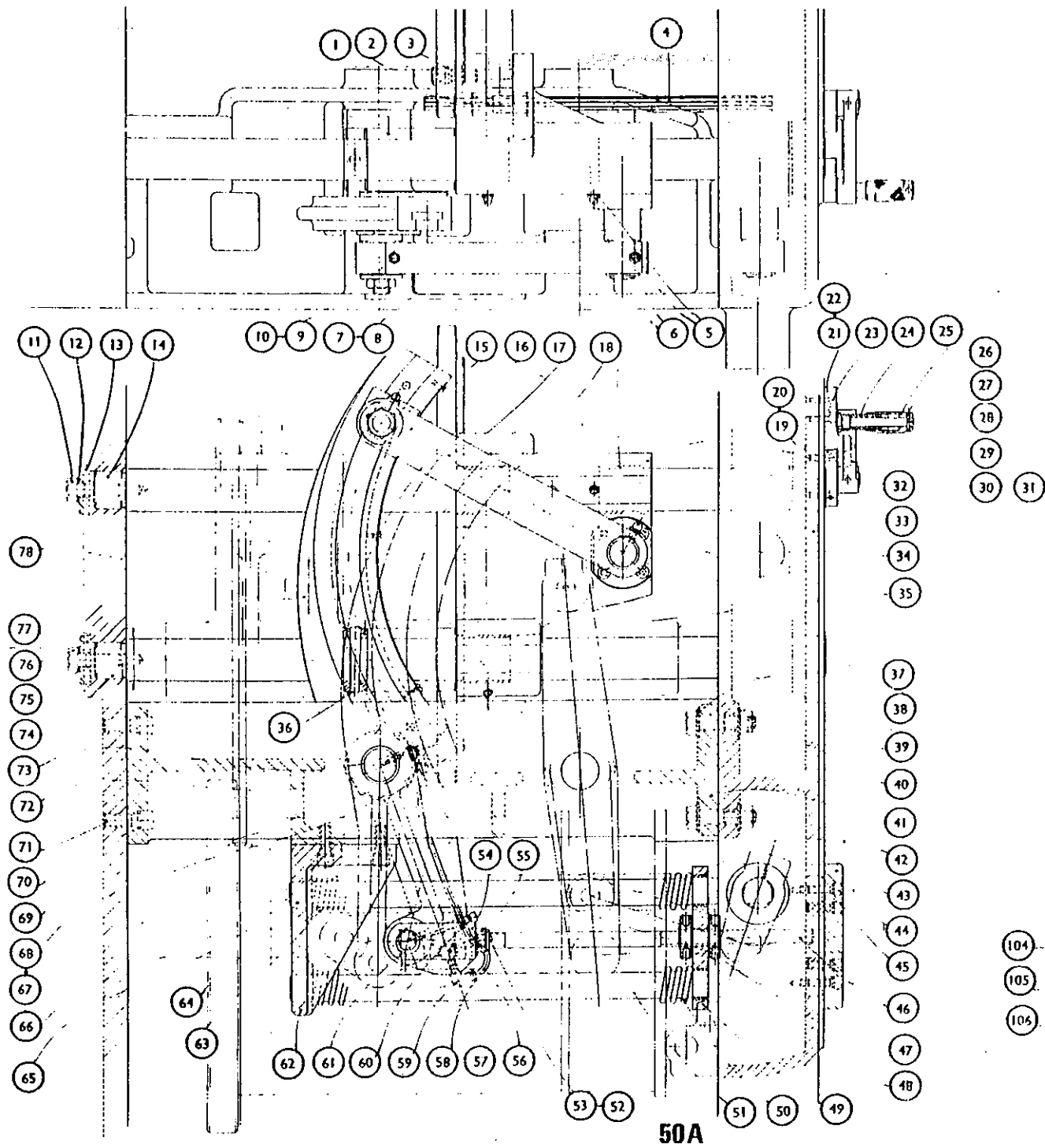

50A

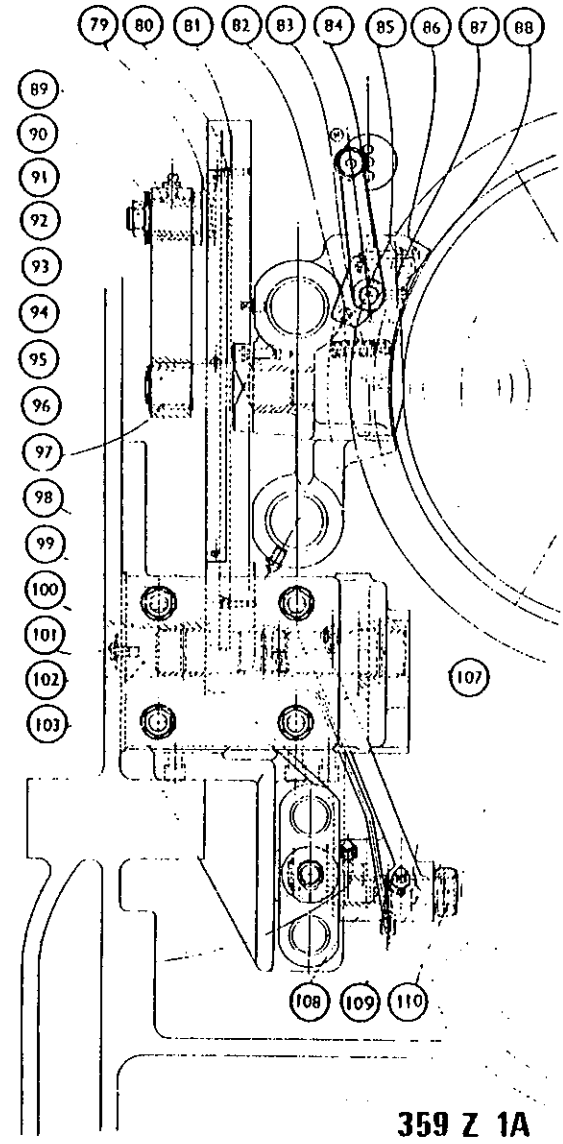

359 Z 1A

**WICKMAN
MULTI-SPINDLE
AUTOMATICS**

LONG BAR FEED

2 1/4"-6 AND 2"-6 CHUCKING MACHINES

INDEX NO.	PART NO.	TITLE.
1	155/0410	1/4" B.S.F. Skt. Hd. Cap Screw, 1 1/2" long.
2	155/0516	3/16" B.S.F. Skt. Hd. Cap Screw, 1" long.
3	236/182216	Oil Retaining Bush.
4	203/05L	3/16" B.S.F. Self-Locking Nut.
5	182/0524	3/16" B.S.F. Skt. Set Screw, T. Pt. 1 1/2" lg.
6	360Y.144	Top Cover (Front).
7	360Y.144	Top Cover (Rear).
8	155/0516	3/16" B.S.F. Skt. Hd. Cap Screw, 1" long.
9	322X.179	Cover Stop.
10	155/0516	3/16" B.S.F. Skt. Hd. Cap Screw, 1" long.
11	322X.165	Cover Guide.
12	212/03GS	1/2" B.S.P. Oil Nipple.
13	210/2525	Yellow Indicator Washer.
14	236/182216	Oil Retaining Bush.
15	360X.110	Pivot Pin.
16	155/0516	3/16" B.S.F. Skt. Hd. Cap Screw, 1" long.
17	322X.179	Cover Stop.
18	236/182216	Oil Retaining Bush.
19	360X.111	Pivot Pin.
20	236/182216	Oil Retaining Bush.
21	210/2525	Yellow Indicator Washer.
22	210/2525	Yellow Indicator Washer.
23	155/0410	1/4" B.S.F. Socket Head Cap Screw.
24	358X.108	Pivot Bolt.
25	165/206	2 B.A. Round Head Screw, 1/2" long.
26	212/4518	1/2" B.S.F. Angled Oil Nipple.
27	210/2525	Yellow Indicator Washer.
28	341X.116	Slotted Washer.
29	203/14L	1/2" B.S.F. Self-Locking Nut.
30	360Z.102	End Bracket.
31	236/202424	Oil Retaining Bush.
32	360Y.118	Link Pivot.
33	360X.113	Link Pivot.
34	212/03GS	1/2" B.S.P. Oil Nipple.
35	210/2525	Yellow Indicator Washer.
36	101/115	1 1/2" dia. External Circlip.
37	236/202416	Oil Retaining Bush.
38	360X.107	Guide Bar.
39	155/0616	1/2" B.S.F. Skt. Hd. Cap Screw, 1" long.
40	360X.113	Link Pivot.
41	203/14	1/2" B.S.F. Self-Locking Nut.
42	360X.108	Pivot Bolt.
43	360X.119	Sleeve.
44	341X.116	Slotted Washer.
45	236/202416	Oil Retaining Bush.
46	360X.112	Lever Pivot.
47	212/4518	1/2" B.S.P. Angled Oil Nipple.
48	360X.107	Guide Bar.
49	203/05L	3/16" B.S.F. Self-Locking Nut.
50	143/1016D	3/16" dia. Mills Grooved Pin, 1" long.
51	212/03GS	1/2" B.S.P. Oil Nipple.
52	356V.109	Pivot Shaft.
53	236/242828	Oil Retaining Bush.
54	558X.125B	Plunger Housing.
55	558X.126B	Plunger.
56	558X.127A	Knob.
57	558X.128	Spring.

INDEX NO.	PART NO.	TITLE.
58	558X.124A	Spring Plunger.
59	558X.129A	Spring.
60	358X.126	Fulcrum Pin.
61	358V.105	Pusher Plate.
62	203/05L	3/16" B.S.F. Self-Locking Nut.
63	182/0520	3/16" B.S.F. Skt. Set Screw, T. Pt. 1 1/2" lg.
64	360X.123	Stop Pin.
65	178/0516	3/16" B.S.F. Skt. Set Screw, 1/4" Dog, 1" lg.
66	236/242828	Oil Retaining Bush.
67	358X.112	Cam Roller.
68	358X.107	Roller Pin.
69	194/1	1/4" B.S.P. Socket Pipe Plug.
70	236/141820	Oil Retaining Bush.
71	101/9	1 1/2" dia. External Circlip.
72	360X.121	Link Pin.
73	198/18	1/2" Internal Shakeproof Washer.
74	358X.155	Retaining Plate.
75	358Z.103A	Connecting Bridge.
76	183/0624	1/4" B.S.F. Sq. Hd. Set Screw, T. Pt. 1 1/2" lg.
77	203/06L	1/2" B.S.F. Self-Locking Nut.
78	173/10	1/2" B.S.F. Hexagon Nut.
79	170/1044	1/2" B.S.F. Hex. Hd. Bolt, 2 1/2" long.
80	130/10	1/2" Plain Washer.
81	155/0620	1/2" B.S.F. Skt. Hd. Cap Screw, 1 1/2" long.
82	CT.685	Oil Retaining Bush.
83	358X.152	Spring Guide.
84	358X.151	Spring Stud.
85	358X.152	Spring Guide.
86	358X.120A	Locknut.
87	358X.153	Pressure Plate.
88	358X.120A	Locknut.
89	CT.685	Oil Retaining Bush.
90	358X.161	Spring.
91	203/06L	1/2" B.S.F. Self-Locking Nut.
92	183/0632	1/4" B.S.F. Sq. Hd. Set Screw, T. Pt. 2" lg.
93	203/12L	1/2" B.S.F. Self-Locking Nut.
94	358X.165	Connecting Block.
95	215/3	3/16" Tubing Nut.
96	221/3	3/16" Tubing Sleeve.
97	219/17	3/16" Male Elbow Adaptor.
98	183/0640	1/4" B.S.F. Sq. Hd. Set Screw, T. Pt. 2 1/2" lg.
99	225/3050	Copper Tube.
100	215/3	3/16" Tubing Nut.
101	208/0318	3/16" Tubing Sleeve.
102	358Z.172	T. Single Banjo, 1/2" B.S.P.
103	358Z.171	Bar Feed Cam—Return.
104	360Z.104	Bar Feed Cam—Forward.
105	155/1032	Bar Feed Lever.
106	167/1032	1/2" B.S.F. Skt. Hd. Cap Screw, 2" long.
107	358X.117	1/2" B.S.F. Hex. Hd. Set Screw, 2" long.
108	198/18	1/2" Internal Shakeproof Washer.
109	167/1032	1/2" B.S.F. Hex. Hd. Set Screw, 2" long.
110	358X.162	Stop Collar.
111	125/3248	1/2" Taper Pin, 3" long.
112	236/323640	Oil Retaining Bush.
	165/406	4 B.A. Round Head Screw, 1/2" long.

INDEX NO.	PART NO.	TITLE.
113	360X.136	Instruction Plate.
114	236/323640	Oil Retaining Bush.
115	156/208	2 B.A. Skt. Hd. Cap Screw, 1/2" long.
116	203/2	2 B.A. Self-Locking Nut.
117	360Z.101	Bar Feed Slide.
118	143/1016D	3/16" dia. Mills Grooved Pin, 1" long.
119	360Y.109	Scale.
120	101/22	2" External Circlip.
121	164/0408	1/2" B.S.F. Round Head Screw, 1/2" long.
	203/04	1/2" B.S.F. Self-Locking Nut.
122	122X.116	Spring Catch.
123	122X.204	Latch Post.
124	167/0516	3/16" B.S.F. Hex. Hd. Set Screw, 1" long.
125	155/0420	1/2" B.S.F. Skt. Hd. Cap Screw, 1 1/2" long.
126	360V.140	Guide Bracket.
127	203/05L	1/2" B.S.F. Self-Locking Nut.
128	322X.165	Cover Guide.
129	155/0516	3/16" B.S.F. Skt. Hd. Cap Screw, 1" long.
130	360Y.143	Hinged Cover (Rear).
131	360Y.146	Hinged Cover (Front).
132	360Y.145	Cover Modifications.
133	358V.119	Link.
134	360X.151	Guard Rail (Rear).
135	155/1024	1/2" B.S.F. Skt. Hd. Cap Screw, 1 1/2" long.
	154/10	1/2" Spring Washer.
136	360X.150	Guard Rail (Front).
137	358X.167	Pin.
138	203/05L	1/2" B.S.F. Self-Locking Nut.
139	183/0528	3/16" B.S.F. Sq. Hd. Set Screw, T. Pt. 1 1/2" lg.
	358X.170	Spring.
140	360X.153	Spring—Safety Link.
	360X.154	Spring—Safety Link.
141	358X.168	Plunger.
142	358Z.158	Thrust Ring.
143	182/0514	3/16" B.S.F. Skt. Set Screw, T. Pt. 1/2" lg.
144	203/05L	1/2" B.S.F. Self-Locking Nut.
145	358X.169	Plunger Seating.
146	155/0416	1/2" B.S.F. Skt. Hd. Cap Screw, 1" long.
147	360Y.103	Link Body.
148	360Y.105	Operating Lever.
	212/4518	1/2" B.S.P. Oil Nipple.
149	210/2525	Yellow Indicator Washer.
150	203/05L	1/2" B.S.F. Self-Locking Nut.
151	182/0524	3/16" B.S.F. Skt. Set Screw, T. Pt. 1 1/2" lg.
152	122X.116	Spring Catch.
153	203/04	1/2" B.S.F. Self-Locking Nut.
	164/0408	1/2" B.S.F. Round Head Screw 1/2" long
154	155/0424	1/2" B.S.F. Skt. Hd. Cap Screw, 1 1/2" long.
155	122X.204	Latch Post.
156	203/04L	1/2" B.S.F. Self-Locking Nut.
157	360Y.106	Fulcrum Lever.
158	360Y.147	Fixed Cover (Front).
159	360X.148	Support Block.
160	173/08	1/2" B.S.F. Hexagon Nut.
161	360X.152	Rail Support.

List of Parts for
PLATE No. 51
(Drawing No. 360 Z 1)

WHEN ORDERING SPARE PARTS ALWAYS QUOTE THE SERIAL NUMBER OF THE MACHINE

BAR FEED—3rd STATION
2½"-6D AND 2"-6D BAR MACHINES

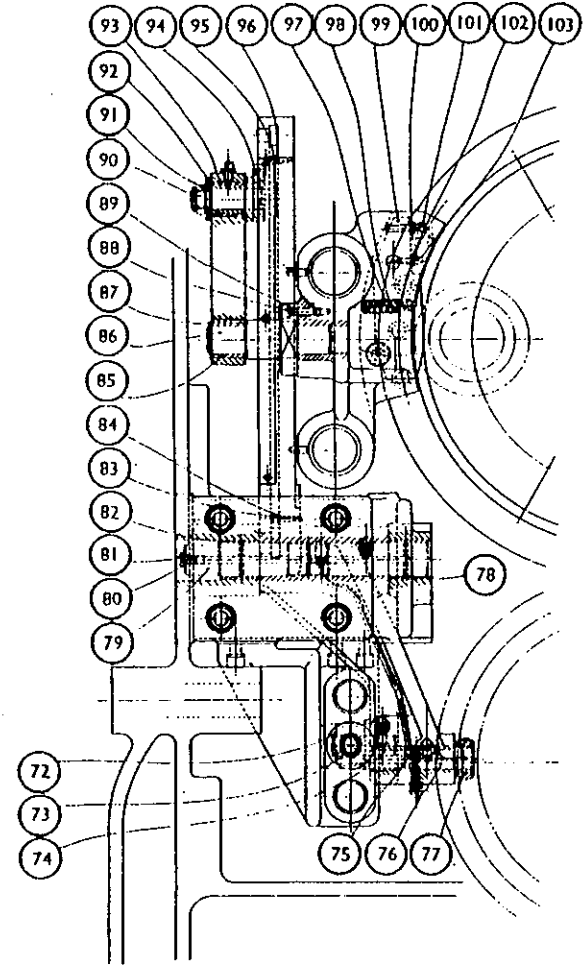
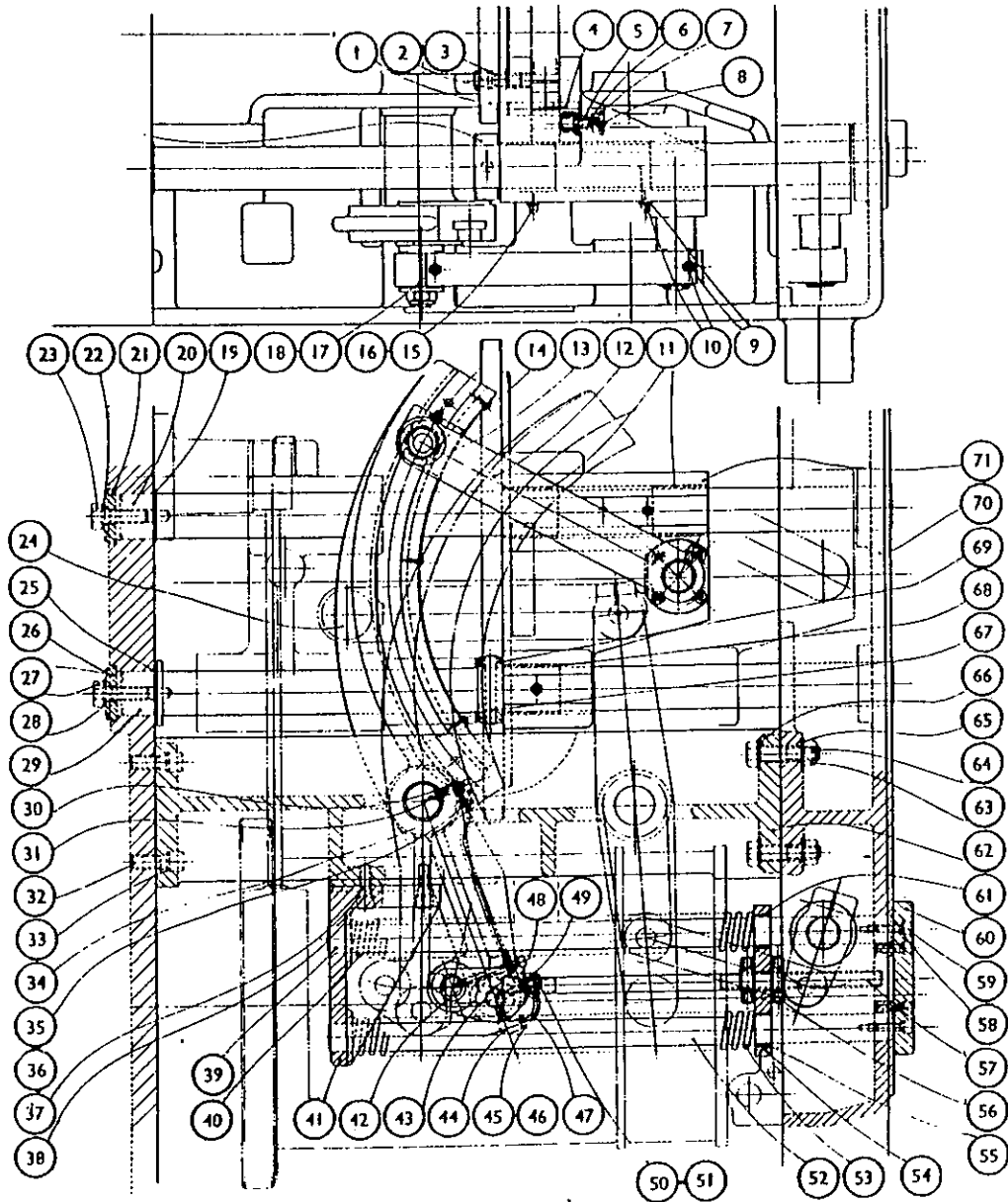

List of Parts for
 PLATE No. 50
 (Drawing No. 359 Z 1)

**WICKMAN
MULTI-SPINDLE
AUTOMATICS**

BAR FEED MECHANISM — REAR

2½"—6D BAR MACHINE

Commencing
M/c No. 9302

INDEX NO.	PART NO.	TITLE
1	359Z.116A	Thrust Ring.
2	155/1024	¾" B.S.F. Cap Screw 1½" long.
3	154/10	¾" Spring Washer.
4	358X.130	Splined Shaft.
5	210/2525	Yellow Indicator Washer.
6	212/4518	½" B.S.P. Oiler.
7	210/2525	Yellow Indicator Washer.
8	212/18	½" B.S.P. Oiler.
9	212/4518	½" B.S.P. Oiler.
10	210/2525	Yellow Indicator Washer.
11	167/1032	¾" B.S.F. Hexagon Head Screw 2" long.
12	198/18	¾" Shakeproof Washer.
13	358X.117	Guide Washer.
14	358X.157A	Guide Bar.
15	165/206	2 B.A. Round Head Screw ¾" long.
16	359Y.109	Bar Feed Scale — Rear
17	359X.119	Link.
18	236/323640	Oil Retaining Bush.
19	155/0516	⅞" B.S.F. Cap Screw 1" long.
20	154/05	⅞" Spring Washer.
21	158X.177A	Plate.
22	154/04	½" Spring Washer.
23	155/0416	½" B.S.F. Cap Screw 1" long.
24	158X.154	Spring Housing.
25	158X.156	Plunger Knob.
26	125/0816	Taper Pin ¼" × 1" long.
27	158X.159	Plunger.
28	MSC.155	Spring ½" o/d × 2½" long.
29	358X.133	Bearing Block.
30	158X.132B	Lever.
31	125/1620	Taper Pin ¼" dia. × 1½" long.
32	359Z.101B	Bar Feed Slide — Rear.
33	359Z.108	End Bracket.
34	358X.162	Stop Collar.
35	236/323640	Oil Retaining Bush.
36	125/3248	Taper Pin ¼" dia. × 3" long.
37	130/10	¾" Washer.

INDEX NO.	PART NO.	TITLE
38	198/18	¾" Shakeproof Washer.
39	170/1044	¾" B.S.F. Hexagon Head Bolt 2½" long.
40	173/10	¾" B.S.F. Hexagon Nut.
41	359Z.103A	Connecting Bridge — Rear.
42	CT.685	Oil Retaining Bush (Compo.)
43	358X.155	Retaining Plate.
44	155/0620	¾" B.S.F. Cap Screw 1½" long.
45	154/06	¾" Spring Washer.
46	359X.151	Spring Stud.
47	358X.120A	Locknut.
48	CT.685	Oil Retaining Bush (Compo.)
49	358X.153	Pressure Plate.
50	359X.161	Spring.
51	359X.152	Spring Guide.
52	203/06L	¾" B.S.F. Self Lock Locknut.
53	183/0632	¾" Square Head Set Screw 2" long.
54	358X.165	Connecting Block.
55	203/12L	¾" Self Lock Locknut.
56	225/3050	Copper Tube ⅞" o/d × 16" long.
56	14.02.456	Copper Tube 4mm o/d × 16" long
57	14.08.04	Tubing Sleeve 4mm
58	14.07.04	Tubing Nut 4mm
59	14.75.0402	Male Elbow 4mm
61	183/0648	¾" Square Head Set Screw.
62	359Y.121	Bracket.
63	359X.161	Spring.
64	359X.152	Spring Guide.
65	155/0824	½" B.S.F. Cap Screw 1½" long.
66	154/08	½" Spring Washer.
67	221/3	⅞" Tubing Sleeve.
68	215/3	⅞" Tubing Nut.
69	219/17	⅞" Male Elbow.
70	154/10	¾" Spring Washer.
71	155/1028	¾" B.S.F. Cap Screw 1½" long.
72	183/0624	¾" Square Head Set Screw 1½" long.
73	203/06L	¾" B.S.F. Self Lock Locknut.
74	358X.157A	Guide Bar.

INDEX NO.	PART NO.	TITLE
75	198/18	¾" Shakeproof Washer.
	167/1032	¾" B.S.F. Hexagon Head Set Screw 2" long.
76	358X.117	Guide Washer.
77	359Z.104A	Bar Feed Lever — Rear.
78	359V.127	Link Pivot.
79	155/0410	½" B.S.F. Cap Screw ¾" long.
80	154/04	½" Spring Washer.
81	558X.124A	Spring Plunger.
82	558X.129B	Spring.
83	358V.105A	Bar Feed Pusher Plate.
84	203/05L	⅞" B.S.F. Self Lock Locknut.
85	188/0528	⅞" Square Head Set Screw 1½" long.
86	203/06L	¾" B.S.F. Self Lock Locknut.
87	182/0614	¾" Socket Set Screw ¾" long.
88	236/202424	Oil Retaining Bush.
89	341X.116	Slotted Washer.
90	203/14L	¾" B.S.F. Self Lock Locknut.
91	358X.108	Pivot Bolt.
92	154/06	¾" Spring Washer.
93	155/0616	¾" B.S.F. Cap Screw 1" long.
94	101/15	External Circlip 1½"
95	358X.199	Link Pivot.
96	236/202424	Oil Retaining Bush.
97	154/04	½" Spring Washer.
98	155/0410	½" B.S.F. Cap Screw ¾" long.
99	236/242828	Oil Retaining Bush.
100	212/03GS	½" B.S.P. Oiler.
101	210/2525	Yellow Indicator Washer.
102	356V.109	Pivot Shaft.
103	101/9	External Circlip ⅞"
104	236/141820	Oil Retaining Bush.
105	358X.160	Link Pin.
106	236/242828	Oil Retaining Bush.
107	194/1	½" B.S.P. Plug.
108	358X.107	Roller Pin.
109	358X.112	Cam Roller.

List of Parts for
PLATE No. 50A
(Drawing No. 359Z1A)

WHEN ORDERING SPARE PARTS ALWAYS QUOTE THE SERIAL NUMBER OF THE MACHINE

BAR FEED

2 1/4"-6, 2 1/4"-6D, 2"-6 AND 2"-6D BAR MACHINES

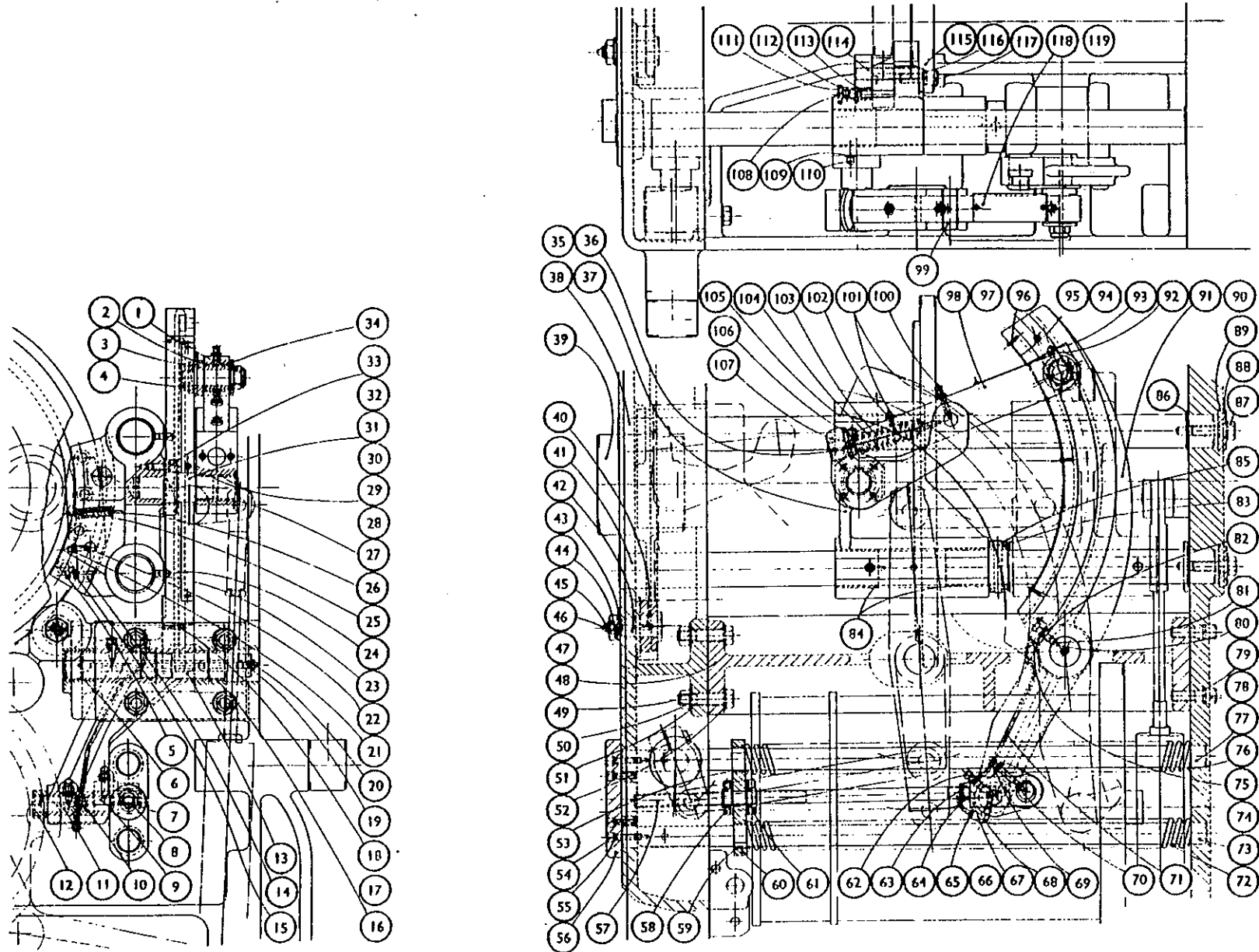

**WICKMAN
MULTI-SPINDLE
AUTOMATICS**

BAR FEED MECHANISM

2½"—6, 2¼"—6D BAR MACHINES

INDEX NO.	PART NO.	TITLE
1	203/14L	½" B.S.F. Self Lock Locknut.
2	236/202424	Oil Retaining Bush.
3	358V.127	Link Pivot.
4	358X.108	Pivot Bolt.
5	188/0528	¼" Square Head Set Screw 1½" long.
6	236/242828	Oil Retaining Bush.
7	101/9	½" External Circlip.
8	236/141820	Oil Retaining Bush
9	358X.160	Link Pin.
10	194/1	½" B.S.P. Plug.
11	358X.107	Roller Pin.
12	358X.112	Cam Roller.
13	356V.109	Pivot Shaft.
14	358V.105A	Bar Feed Pusher Plate.
15	203/05L	¾" B.S.F. Self Lock Locknut.
16	341X.116	Slotted Washer.
17	154/06	½" Spring Washer.
18	155/0616	½" B.S.F. Cap Screw 1" long.
19	358X.123	Link Pivot.
20	358X.199	Link Pivot.
21	236/202416	Oil Retaining Bush.
22	236/202424	Oil Retaining Bush.
23	101/15	External Circlip 1½".
24	558X.124A	Spring Plunger.
25	558X.129B	Spring.
26	212/18	½" B.S.P. Oiler.
27	210/2525	Yellow Indicator Washer.
28	182/0614	½" Socket Set Screw ¾" long.
29	203/06L	½" Self Lock Locknut.
30	212/03GS	½" B.S.P. Oiler.
31	210/2525	Yellow Indicator Washer.
32	155/0410	½" B.S.F. Cap Screw ¾" long.
33	154/04	½" Spring Washer.
34	236/242828	Oil Retaining Bush.
35	210/2525	Yellow Indicator Washer.
36	210/03GS	½" B.S.P. Oiler.
37	130/14	½" Washer.
38	173/14LH	½" B.S.F. Hexagon Locknut.
39	6307/2RS	Sealed Roller Bearing
40	358X.164B	Eccentric Roller Pin
41	158X.140	Spined Bush.
42	358Z.158A	Thrust Ring.
43	154/10	½" Spring Washer.

INDEX NO.	PART NO.	TITLE
44	155/1024	½" B.S.F. Cap Screw 1½" long.
45	172X.107A	Instruction Plate.
46	165/206	2 B.A. Round Head Screw ¾" long.
47	210/2525	Yellow Indicator Washer.
48	212/4518	½" B.S.P. Oiler.
49	358X.167	Pin.
50	154/04	½" Spring Washer.
51	155/0416	½" B.S.F. Cap Screw 1" long.
52	358X.157A	Guide Bar.
53	358Z.101B	Bar Feed Slide.
54	358Z.192	Driving Disc.
55	358Z.150A	Driving Disc.
56	158X.154	Spring Housing.
57	MSC.155	Spring ½" o/d x 2½" long.
58	125/0816	Taper Pin ½" dia. x 1" long.
59	158X.159	Plunger.
60	158X.156	Plunger Knob.
61	154/04	½" Spring Washer.
62	155/0416	½" Cap Screw 1" long.
63	158X.177A	Plate.
64	125/1620	Taper Pin ½" dia. x 1½" long.
65	158X.132B	Lever.
66	154/05	¾" Spring Washer.
67	155/0516	¾" B.S.F. Cap Screw 1" long.
68	358X.133	Bearing Block.
69	358Y.166A	Link Body.
70	358X.169	Plunger Seating.
71	236/323640	Oil Retaining Bush.
72	358X.168	Plunger.
73	360X.153	Spring Safety Link.
74	178/0514	¼" Socket Set Screw ¾" long.
75	203/05L	½" B.S.F. Self Lock Locknut.
76	183/0528	¼" Square Head Set Screw 1½" long.
77	358X.198	Link.
78	358V.119	Bar Feed Link.
79	165/2061	2 B.A. Round Head Screw ¾" long.
80	358Y.109	Bar Feed Scale.
81	358Y.197	Bar Feed Scale — Front.
82	212/4518	½" B.S.P. Oiler.
83	210/2525	Yellow Indicator Washer.
84	358Z.104A	Bar Feed Lever.
85	358Z.196A	Bar Feed Lever Front.
86	358X.117	Guide Washer.

INDEX NO.	PART NO.	TITLE
87	198/18	½" Shakeproof Washer.
88	167/1032	½" B.S.F. Hexagon Head Screw 2" long.
89	125/3248	Taper Pin ½" dia. x 3" long.
90	358X.162	Stop Collar.
91	203/06L	½" B.S.F. Self Lock Locknut.
92	183/0624	½" Square Set Screw 1½" long.
93	14.75.0402	4mm Male Elbow
94	154/10	½" Spring Washer.
95	155/1032	½" B.S.F. Cap Screw 2" long.
96	358X.152	Spring Guide.
97	358X.161	Spring.
98	14.07.04	4mm Tubing Nut
99	14.08.04	4mm Tubing Sleeve
100	358X.152	Spring Guide.
101	358X.161	Spring.
102	358X.130	Splined Shaft.
103	358X.157A	Guide Bar.
104	236/323640	Oil Retaining Bush.
105	3582195	Connecting Bridge Front.
106	358Z.103A	Connecting Bridge.
107	170/1044	½" B.S.F. Hexagon Head Bolt 2½" long.
108	173/10	Hexagon Nut.
109	198/18	½" Shakeproof Washer.
110	130/10	½" Washer.
111	358X.164	Bush
112	155/0620	½" B.S.F. Cap Screw 1½" long.
113	154/06	½" Spring Washer.
114	358X.155	Retaining Plate.
115	358X.151	Spring Stud.
116	358X.120A	Locknut.
117	358X.164	Bush
118	358X.153	Pressure Plate.
119	353X.120A	Locknut.
120	183/0632	¼" Square Head Set Screw 2" long.
121	203/06L	½" B.S.F. Self Lock Locknut.
122	203/12L	½" B.S.F. Self Lock Locknut.
123	14.08.04	Tubing Sleeve 4mm
124	14.07.04	Tubing Nut 4mm
125	358X.165	Connecting Block.
126	14.75.0402	Male Elbow 4mm
127	203/06L	½" B.S.F. Self Lock Locknut.
128	183/0640	½" Square Head Set Screw 2½" long.
129	14.02.406	Copper Tube 4mm o/d x 18" long

List of Parts for
PLATE No. 49A
(Drawing No. 358Z1A)

WHEN ORDERING SPARE PARTS ALWAYS QUOTE THE SERIAL NUMBER OF THE MACHINE

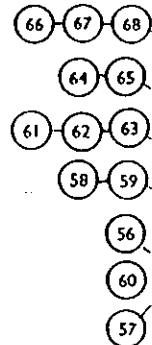
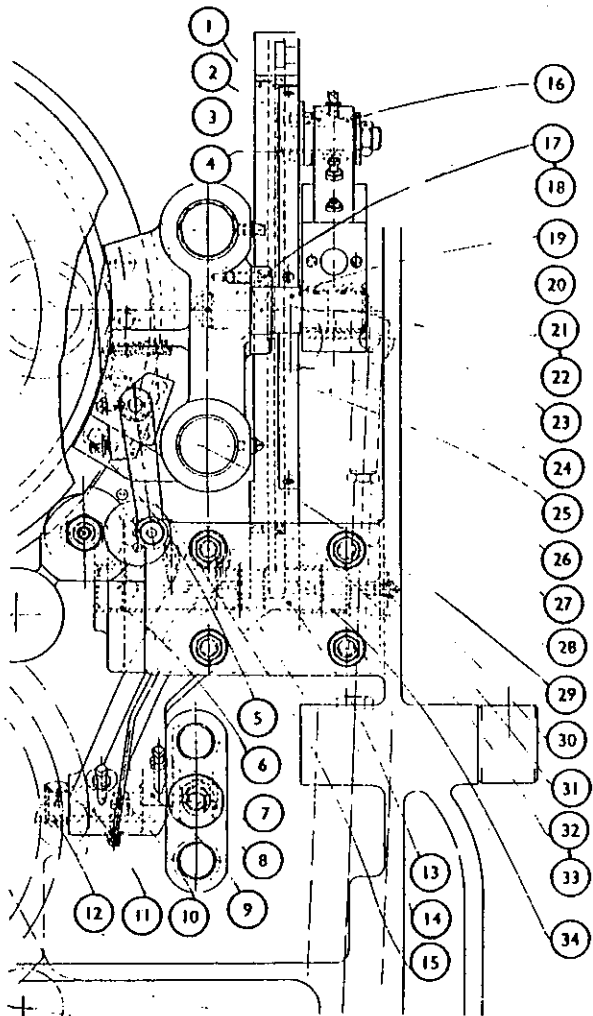

49A

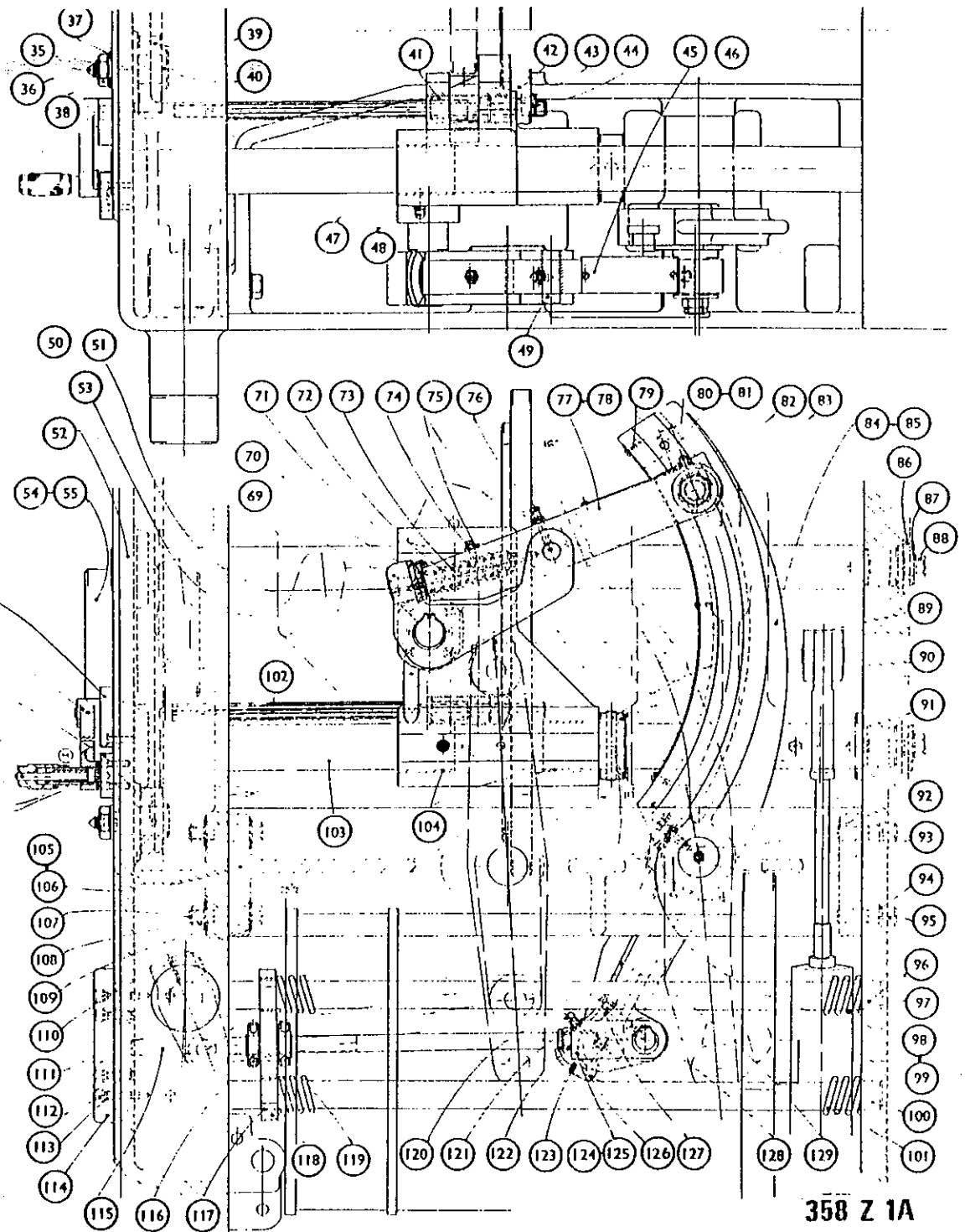

358 Z 1A

**WICKMAN
MULTI-SPINDLE
AUTOMATICS**

**BAR FEED—3rd STATION
2½"-6D AND 2"-6D CHUCKING MACHINES**

INDEX NO.	PART NO.	TITLE.	INDEX NO.	PART NO.	TITLE.
1	359Z.116	Thrust Ring.	53	359X.161	Spring.
2	155/1024	½" B.S.F. Socket Head Cap Screw, 1½" long.	54	358X.153	Pressure Plate.
3	154/10	½" Spring Washer.	55	CT.685	Oil Retaining Bush.
4	358X.126	Fulcrum Pln.	56	358X.120A	Locknut.
5	558X.128	Spring.	57	359X.151	Spring Stud.
6	558X.125B	Plunger, H.S.G.	58	154/06	½" Spring Washer.
7	558X.127A	Knob.	59	155/0620	½" B.S.F. Socket Head Cap Screw, 1½" long.
8	558X.126B	Plunger.	60	358X.155	Retaining Plate.
9	210/2525	Yellow Indicator Washer.	61	CT.685	Oil Retaining Bush.
10	212/4518	½" B.S.P. Oiler.	62	359Z.103	Connecting Bridge, Rear.
11	236/323640	Oil Retaining Bush.	63	173/10	½" B.S.F. Hexagon Nut.
12	159X.119	Link.	64	170/1044	½" B.S.F. Hexagon Head Bolt.
13	359Y.109	Bar Feed Scale, Rear.	65	198/18	½" Shakeproof Washer.
14	165/206	2 B.A. Round Head Screw, ½" long.	66	130/10	½" Flat Washer.
15	212/18	½" B.S.P. Oiler.	67	125/3248	½" dia. Taper Pin, 3" long.
16	210/2525	Yellow Indicator Washer.	68	236/323640	Oil Retaining Bush.
17	212/4518	½" B.S.P. Oiler.	69	358X.162	Stop Collar.
18	210/2525	Yellow Indicator Washer.	70	359Z.108	End Bracket.
19	101/22	2" External Circlip.	71	359Z.101	Bar Feed Slide, Rear.
20	358X.157	Guide Bar.	72	101/9	½" External Circlip.
21	358X.117	Guide Washer.	73	236/141820	Oil Retaining Bush.
22	198/18	½" Shakeproof Washer.	74	358X.160	Link Pin.
23	167/1032	½" B.S.F. Hexagon Head Screw, 2" long.	75	194/1	½" B.S.P. Plug.
24	359Z.104	Bar Feed Lever, Rear.	76	358X.107	Roller Pin.
25	101/22	2" External Circlip.	77	358X.112	Cam Roller.
26	358X.117	Guide Washer.	78	236/242828	Oil Retaining Bush.
27	167/1032	½" B.S.F. Hexagon Head Screw, 2" long.	79	356V.109	Pivot Shaft.
28	198/18	½" Shakeproof Washer.	80	210/2525	Yellow Indicator Washer.
29	358X.157	Guide Bar.	81	212/03GS.	½" B.S.P. Oiler.
30	203/06L	½" B.S.F. Self-Locking Nut.	82	236/242828	Oil Retaining Bush.
31	183/0624	½" B.S.F. Square Head Set Screw, 1½" long.	83	155/0410	½" B.S.F. Socket Head Cap Screw, ½" long.
32	155/1028	½" B.S.F. Socket Head Cap Screw, 1½" long.	84	154/04	½" Spring Washer.
33	154/10	½" Spring Washer.	85	236/202424	Oil Retaining Bush.
34	219/17	½" Male Elbow.	86	358X.199	Link Pivot.
35	215/3	½" Tubing Nut.	87	101/15	1½" External Circlip.
36	221/3	½" Tubing Sleeve.	88	155/0616	½" B.S.F. Socket Head Cap Screw, 1" long.
37	154/08	½" Spring Washer.	89	154/06	½" Spring Washer.
38	155/0824	½" B.S.F. Socket Head Cap Screw, 1½" long.	90	358X.108	Pivot Bolt.
39	359X.152	Spring Guide.	91	203/14L	½" B.S.F. Self-Locking Nut.
40	359X.161	Spring	92	341X.116	Slotted Washer.
41	359Y.121	Bracket.	93	236/202424	Oil Retaining Bush.
42	183/0648	½" B.S.F. Square Head Set Screw, 3" long.	94	359V.127	Link Pivot.
43	203/06L	½" B.S.F. Self-Locking Nut.	95	155/0410	½" B.S.F. Socket Head Cap Screw, ½" long.
44	219/17	½" Male Elbow.	96	154/04	½" Spring Washer.
45	215/3	½" Tubing Nut.	97	558X.124A	Spring Plunger.
46	221/3	½" Tubing Sleeve.	98	558X.129A	Spring.
47	225/3050	½" O.D. Copper Tube, 16" long.	99	358V.105	Bar Feed Pusher Plate.
48	358X.165	Connecting Block.	100	203/05L	½" B.S.F. Self-Locking Nut.
49	203/12L	½" B.S.F. Self-Locking Nut.	101	188/0524	½" B.S.F. Square Head Set Screw, 1½" long.
50	183/0632	½" B.S.F. Square Head Set Screw, 2" long.	102	203/05L	½" B.S.F. Self-Locking Nut.
51	203/06L	½" B.S.F. Self-Locking Nut.	103	182/0520	½" B.S.F. Socket Set Screw, 1½" long.
52	359X.152	Spring Guide.			

List of Parts for
PLATE No. 50
(Drawing No. 359 Z 1)

WHEN ORDERING SPARE PARTS ALWAYS QUOTE THE SERIAL NUMBER OF THE MACHINE

2½"-6, 2½"-6D, 2"-6 AND 2"-6D BAR MACHINES
 6⅝"-6, AND 6⅝"-6D CHUCKING MACHINES

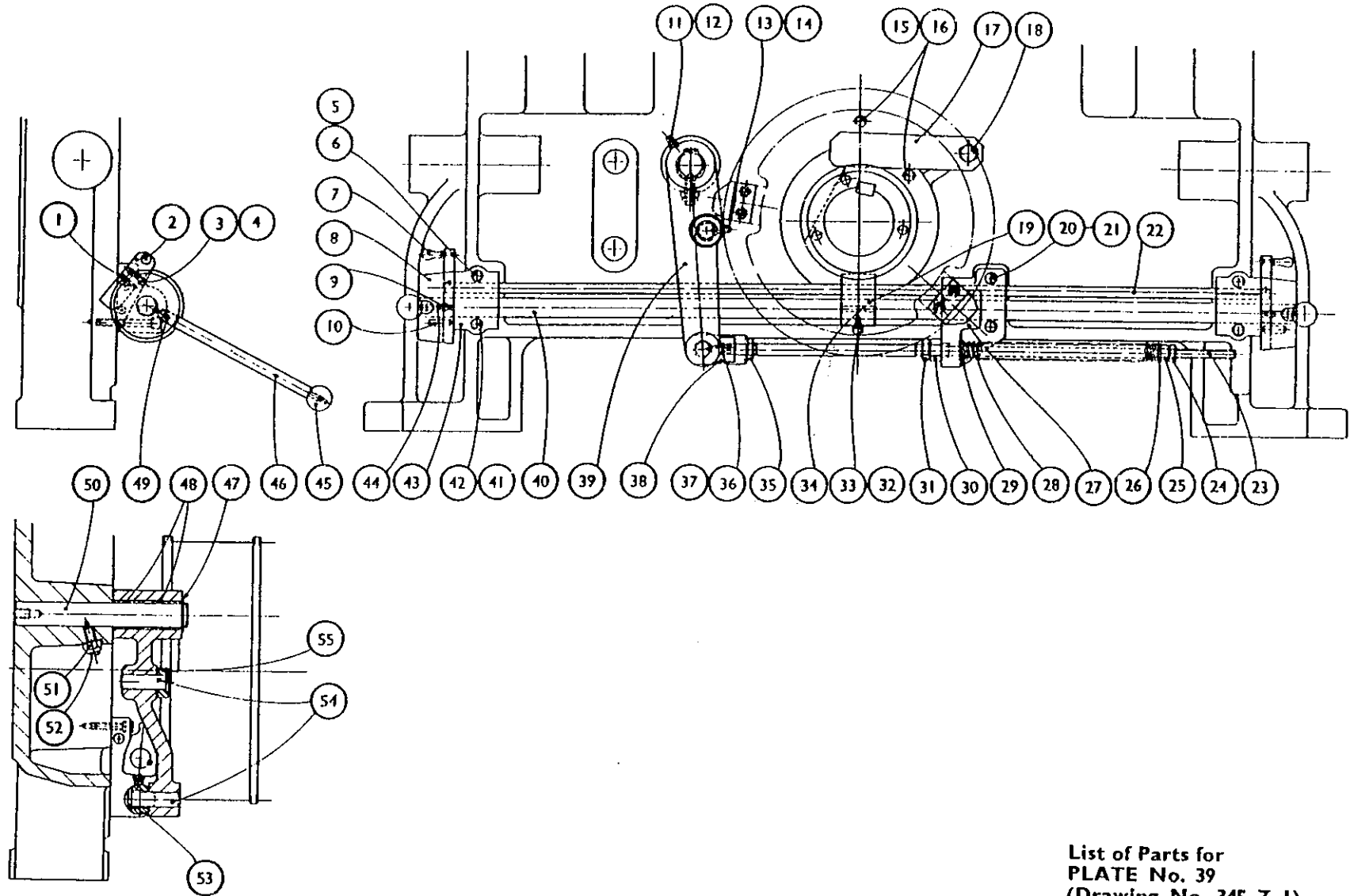

List of Parts for
 PLATE No. 39
 (Drawing No. 345 Z 1)

**WICKMAN
MULTI-SPINDLE
AUTOMATICS**

**INDEXING GEARS
2¼"-6, 2½"-6D, 2"-6 AND 2"-6D BAR MACHINES
6⅝"-6 CHUCKING MACHINE**

INDEX NO.	PART NO.	TITLE.	INDEX NO.	PART NO.	TITLE.
1	351X.120	Link Pin.	32	125/3232	½" dia. Taper Pin, 2" long.
2	203/05	⅜" B.S.F. Self-Locking Nut.	33	361X.152	Spacer.
3	183/0520	⅜" B.S.F. Square Head Screw, Taper Point, 1¼" long.	34	361X.150	Collar.
4	361X.117A	Drum Locking Spring.	35	203/06	⅜" B.S.F. Self-Locking Nut.
5	361X.116	Spring Tube.	36	183/0620	⅜" B.S.F. Square Head Set Screw, Taper Point, 1¼" long.
6	361X.120	Drum Locking Rod (Lower).	37	361V.127	Drum Locking Shaft.
7	183/0628	⅜" B.S.F. Square Head Screw, Taper Point, 1¼" long.	38	155/0724	⅜" B.S.F. Socket Head Cap Screw, 1½" long.
8	203/06	⅜" B.S.F. Self-Locking Nut.	39	154/07	⅜" Spring Washer.
9	182/0624	⅜" B.S.F. Socket Set Screw, Taper Point, 1¼" long.	40	361V.153	Operating Shaft Bearing Bracket.
10	203/06	⅜" B.S.F. Self-Locking Nut.	41	236/283228	Oil Retaining Bush.
*11	346Z.112D	Geneva Arm and Drum Locking Cam	42	155/0724	⅜" B.S.F. Socket Head Cap Screw, 1½" long.
12	558X.112	Cam Roller.	43	154/07	⅜" Spring Washer.
13	346X.113	Roller Pin (Geneva Arm).	44	361V.106B	Lever.
14	123X.104	Roller.	45	361X.121	Link End.
15	361X.133	Roller Pin.	46	203/10	⅜" B.S.F. Pinnacle Nut.
16	361Y.101	Drum Locking Lever.	47	361X.119	Drum Locking Rod (Upper).
17	101/6	⅜" dia. External Circlip.	48	357X.151	Drum Locking Rod (Upper).
18	561X.121A	Pin for Drum Locking Rod Link.	49	346V.103	Geneva Wheel Gear.
19	101/18	1½" dia. External Circlip.	50	155/0514	⅜" B.S.F. Socket Head Cap Screw, ⅜" long.
20	561X.144	Washer.	51	154/05	⅜" Spring Washer.
21	236/242828	Oil Retaining Bush.	52	203/10	⅜" B.S.F. Pinnacle Nut.
22	361X.135A	Locking Lever Shaft.	53	125/1632	1" dia. Taper Pin, 2" long.
23	361X.136	Locking Lever Boss.	54	361X.122	Spring Retaining Nut.
24	155/1028	⅜" B.S.F. Socket Head Cap Screw, 1½" long.	55	346Y.101	Geneva Wheel.
25	154/10	⅜" Spring Washer.	56	155/0828	⅜" B.S.F. Socket Head Cap Screw, 1½" long.
26	154/10	⅜" Spring Washer.	57	154/08	⅜" Spring Washer.
27	155/1032	⅜" B.S.F. Socket Head Cap Screw, 2" long.	58	561X.118A	End Cap for Spring Tube.
28	346X.107	Spigot for Geneva Wheel Support.	59	173/10L	⅜" B.S.F. Hexagon Locknut.
29	346V.104	Geneva Wheel Support.	60	561X.147	Link.
30	154/07	⅜" Spring Washer.			
31	155/0720	⅜" B.S.F. Socket Head Cap Screw, 1¼" long.			
*11	346V.115	Geneva Arm and Drum Locking Cam (2¼"-6S only)			

List of Parts for
PLATE No. 40
(Drawing No. 346 Z 1)

WHEN ORDERING SPARE PARTS ALWAYS QUOTE THE SERIAL NUMBER OF THE MACHINE

INDEXING GEARS

2¼"-6, 2¼"-6D, 2"-6 AND 2"-6D BAR MACHINES

6⅝"-6 CHUCKING MACHINE

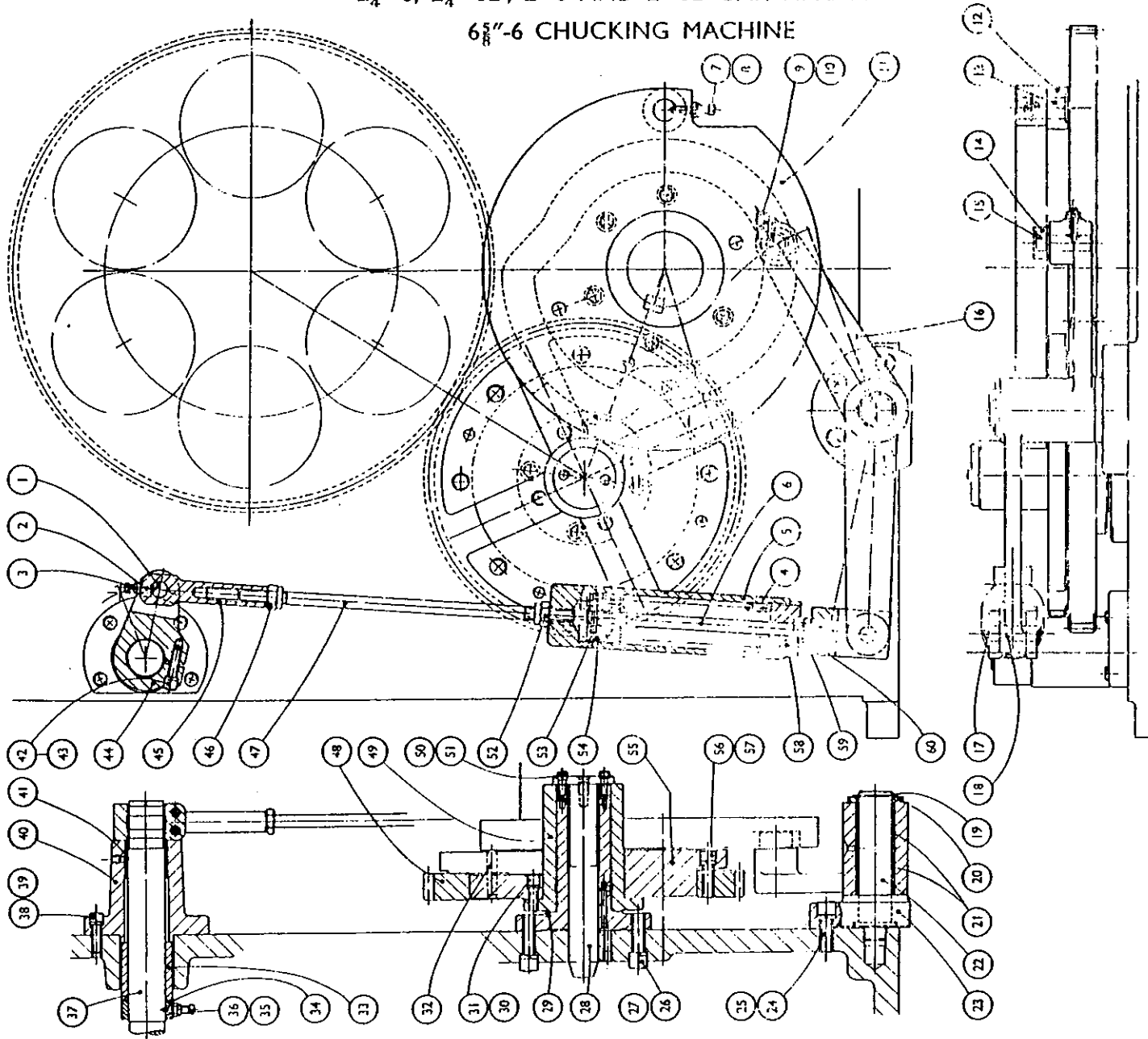

**WICKMAN
MULTI-SPINDLE
AUTOMATICS**

**INDEXING GEARS
6 $\frac{5}{8}$ "-6D CHUCKING MACHINE**

INDEX NO.	PART NO.	TITLE.	INDEX NO.	PART NO.	TITLE.
1	361V.141	Drum Locking Shaft.	35	154/07	$\frac{7}{16}$ " Spring Washer.
2	361X.150	Collar.	36	155/0724	$\frac{7}{16}$ " B.S.F. Socket Head Cap Screw, 1 $\frac{1}{2}$ " long.
3	361X.152	Spacer.	37	361V.1068	Lever.
4	154/07	$\frac{7}{16}$ " Spring Washer.	38	155/0514	$\frac{7}{16}$ " B.S.F. Socket Head Cap Screw, $\frac{3}{4}$ " long.
5	155/0724	$\frac{7}{16}$ " B.S.F. Socket Head Cap Screw, 1 $\frac{1}{2}$ " long.	39	154/05	$\frac{7}{16}$ " Spring Washer.
6	361V.142	Operating Shaft Bearing Bracket.	40	349X.109	Retaining Plate.
7	236/283228	Oil Retaining Bush.	41	349V.108	Compound Gear Shaft.
8	183/0110	$\frac{7}{16}$ " B.S.F. Square Head Set Screw, Taper Point, 1 $\frac{1}{2}$ " long.	42	155/0514	$\frac{7}{16}$ " B.S.F. Socket Head Cap Screw, $\frac{3}{4}$ " long.
9	203/05	$\frac{3}{8}$ " B.S.F. Self-Locking Nut.	43	154/05	$\frac{7}{16}$ " Spring Washer.
10	351X.120	Link Pin.	44	346V.103	Geneva Wheel Bearing.
11	183/0628	$\frac{1}{2}$ " B.S.F. Square Head Screw, Taper Point, 1 $\frac{1}{2}$ " long.	45	346Y.101	Geneva Wheel.
12	203/06	$\frac{1}{2}$ " B.S.F. Self-Locking Nut.	46	101/18	1 $\frac{1}{2}$ " dia. External Circlip.
13	346Z.112B	Geneva Arm and Drum Locking Cam.	47	561X.144	Washer.
14	182/0624	$\frac{1}{2}$ " B.S.F. Socket Set Screw, Taper Point, 1 $\frac{1}{2}$ " long.	48	236/242828	Oil Retaining Bush.
15	203/06	$\frac{1}{2}$ " B.S.F. Self-Locking Nut.	49	361X.143	Locking Lever Shaft.
16	558X.112	Cam Roller.	50	361X.136	Locking Lever Boss.
17	346X.113	Roller Pin (Geneva Arm).	51	155/1028	$\frac{1}{2}$ " B.S.F. Socket Head Cap Screw, 1 $\frac{1}{2}$ " long.
18	123X.104	Roller.	52	154/10	$\frac{1}{2}$ " Spring Washer.
19	361X.133	Roller Pin.	53	349Y.102	Geneva Wheel Gear.
20	361Y.138	Drum Locking Lever.	54	125/3232	$\frac{1}{2}$ " dia. Taper Pin, 2" long.
21	561X.121A	Pin for Drum Locking Rod Link.	55	155/1032	$\frac{1}{2}$ " B.S.F. Socket Head Cap Screw, 2" long.
22	101/6	$\frac{3}{4}$ " dia. External Circlip.	56	154/10	$\frac{1}{2}$ " Spring Washer.
23	561X.147	Link.	57	346X.107	Spigot for Geneva Wheel Support.
24	173/10L	$\frac{1}{2}$ " B.S.F. Hexagon Locknut.	58	346V.104	Geneva Wheel Support.
25	561X.118A	End Cap for Spring Tube.	59	155/0720	$\frac{7}{16}$ " B.S.F. Socket Head Cap Screw, 1 $\frac{1}{2}$ " long.
26	361X.117A	Drum Locking Spring.	60	154/07	$\frac{7}{16}$ " Spring Washer.
27	361X.120	Drum Locking Rod (Lower).	61	236/323624	Oil Retaining Bush.
28	361X.122	Spring Retaining Nut.	62	155/1028	$\frac{1}{2}$ " B.S.F. Socket Head Cap Screw, 1 $\frac{1}{2}$ " long.
29	125/1632	$\frac{1}{2}$ " dia. Taper Pin, 2" long.	63	154/10	$\frac{1}{2}$ " Spring Washer.
30	361X.116	Spring Tube.	64	349Y.111	Lower Compound Gear.
31	203/10	$\frac{1}{2}$ " B.S.F. Pinnacle Nut.	65	349Y.110	Upper Compound Gear.
32	361X.119	Drum Locking Rod (Upper).	66	183/0620	$\frac{1}{2}$ " B.S.F. Square Head Set Screw, Taper Point, 1 $\frac{1}{2}$ " long.
33	203/10	$\frac{1}{2}$ " B.S.F. Pinnacle Nut.	67	203/06	$\frac{1}{2}$ " B.S.F. Self-Locking Nut.
34	361X.121	Link End.			

List of Parts for
PLATE No. 41
(Drawing No. 349 Z 1)

WHEN ORDERING SPARE PARTS ALWAYS QUOTE THE SERIAL NUMBER OF THE MACHINE

INDEXING GEARS
6 $\frac{3}{8}$ "-6D CHUCKING MACHINE

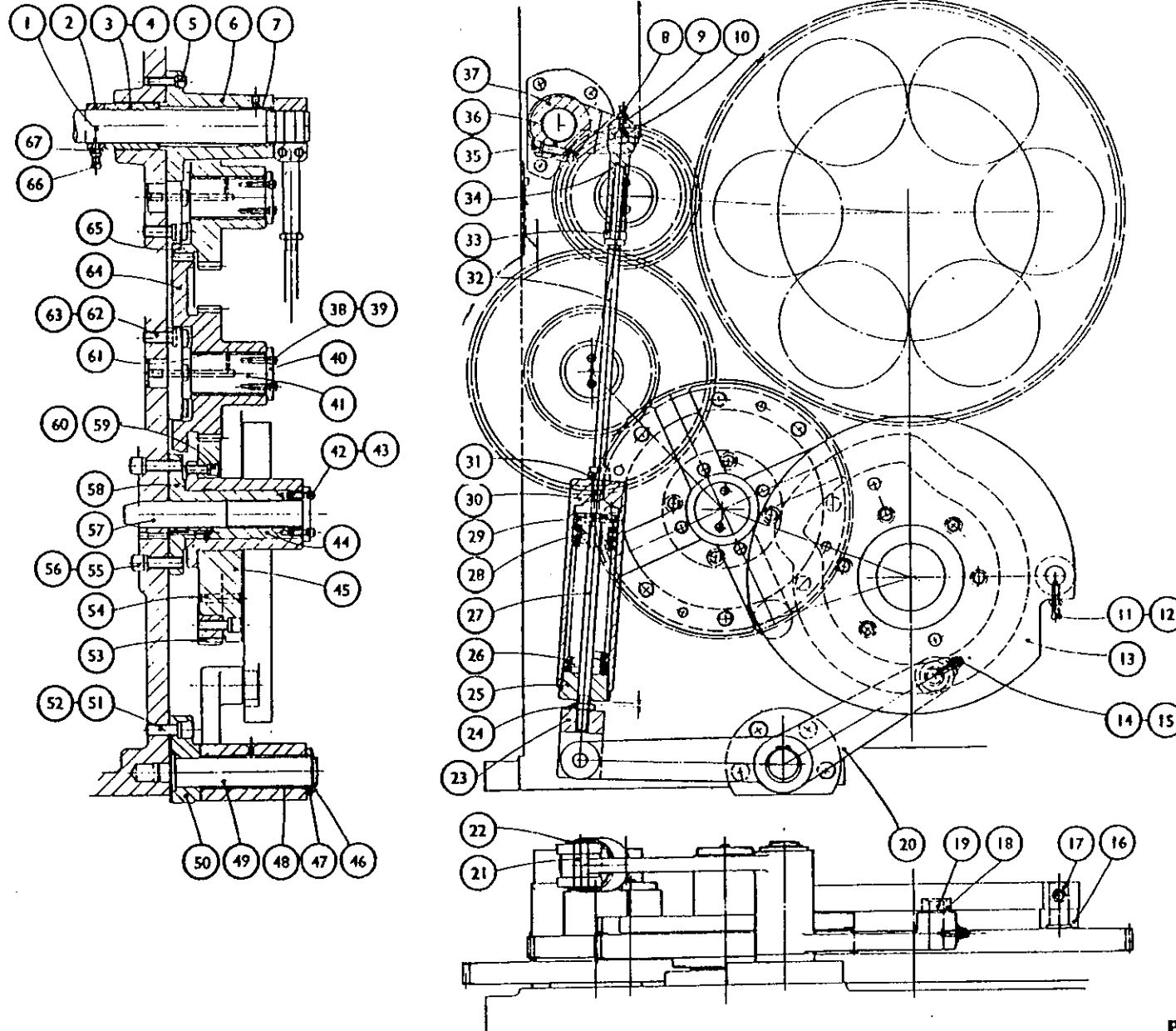

**WICKMAN
MULTI-SPINDLE
AUTOMATICS**

BAR STOP

2¼"-6, 2¼"-6D, 2"-6 AND 2"-6D BAR MACHINES

INDEX NO.	PART NO.	TITLE.	INDEX NO.	PART NO.	TITLE.
1	241/13	1½" dia. Black Bakelite Knob.	33	203/05	⅜" B.S.F. Locking Nut.
2	122/1836T	Tapped Key, 2¼" long.	34	183/0524	⅜" B.S.F. Square Head Screw, Taper Point, 1½" long.
3	350V.108	Bar Stop Bracket.	35	350V.115	Bar Stop Lever.
4	154/10	⅜" Spring Washer.	36	188/0628	⅜" B.S.F. Square Head Set Screw, 1½" long.
5	155/1024	⅜" B.S.F. Socket Head Cap Screw, 1½" long.	37	203/06	⅜" B.S.F. Self-Locking Nut.
6	350X.109	Bar Stop.	38	183/0624	⅜" B.S.F. Square Head Screw, Taper Point, 1½" long.
7	350X.138	Operating Shaft Bearing.	39	182/0620	⅜" B.S.F. Socket Set Screw, Taper Point, 1½" long.
8	350X.142	Stop Peg.	40	203/06	⅜" B.S.F. Self-Locking Nut.
9	350X.135	Front Bar Stop Cam.	41	350X.114	Bearing For Slide Base.
10	155/0612	⅜" B.S.F. Socket Head Cap Screw, ¾" long.	42	350X.127	Locknut.
11	203/05	⅜" B.S.F. Self-Locking Nut.	43	350V.113	Adjusting Sleeve.
12	183/0524	⅜" B.S.F. Square Head Screw, Taper Point, 1½" long.	44	350Y.112	Bar Stop Shaft.
13	350V.136	Front Bar Stop Cam.	45	350X.146	Feed Lever.
14	350X.122	Front Bar Stop Spring.	46	550X.114	Locating Pin.
15	350X.123	Spring Anchor.	47	182/0614	⅜" B.S.F. Socket Set Screw, Taper Point, ⅞" long.
16	550X.134	Spring Seat.	48	350X.125	Spring Anchor.
17	550X.133	Retaining Washer.	49	350Y.104	Bar Stop Cam Lever.
18	550X.134	Spring Seat.	50	101/17	1½" dia. External Circlip.
19	183/0524	⅜" B.S.F. Square Head Screw, Taper Point, 1½" long.	51	350X.126	Spacer.
20	203/05	⅜" B.S.F. Self-Locking Nut.	52	236/222616	Oil Retaining Bush.
21	350X.139	Pin for Spring Housing.	53	123X.103	Roller Pin.
22	127/0814	½" dia. Split Cotter Pin, 1½" long.	54	141X.121	Cam Roller.
23	550X.137	Spring Retaining Nut.	55	550X.126A	Adjusting Washer.
24	550X.133	Retaining Washer.	56	236/242816	Oil Retaining Bush.
25	550Y.130	Spring Housing.	57	550X.126A	Adjusting Washer.
26	350X.132	Compression Spring.	58	101/18	1½" dia. External Circlip.
27	550X.135	Adjusting Nut.	59	210/1725	Yellow Indicator Washer.
28	125/1220	½" dia. Taper Pin, 1½" long.	60	212/04	⅜" B.S.F. Autolub Nipple.
29	350X.140	Link Rod.	61	350V.137A	Stop Shaft Bracket.
30	203/10L	⅜" B.S.F. Self-Locking Nut (Thin).	62	141/6	⅜" dia. Tapped Taper Pin, 1½" long.
31	361X.121	Link End.	63	154/08	⅜" Spring Washer.
32	351X.120	Link Pin.	64	155/0832	⅜" B.S.F. Socket Head Cap Screw, 2" long.

List of Parts for
PLATE No. 42
(Drawing No. 350 Z 1)

WHEN ORDERING SPARE PARTS ALWAYS QUOTE THE SERIAL NUMBER OF THE MACHINE

BAR STOP

2 1/4"-6, 2 1/4"-6D, 2"-6 AND 2"-6D BAR MACHINES

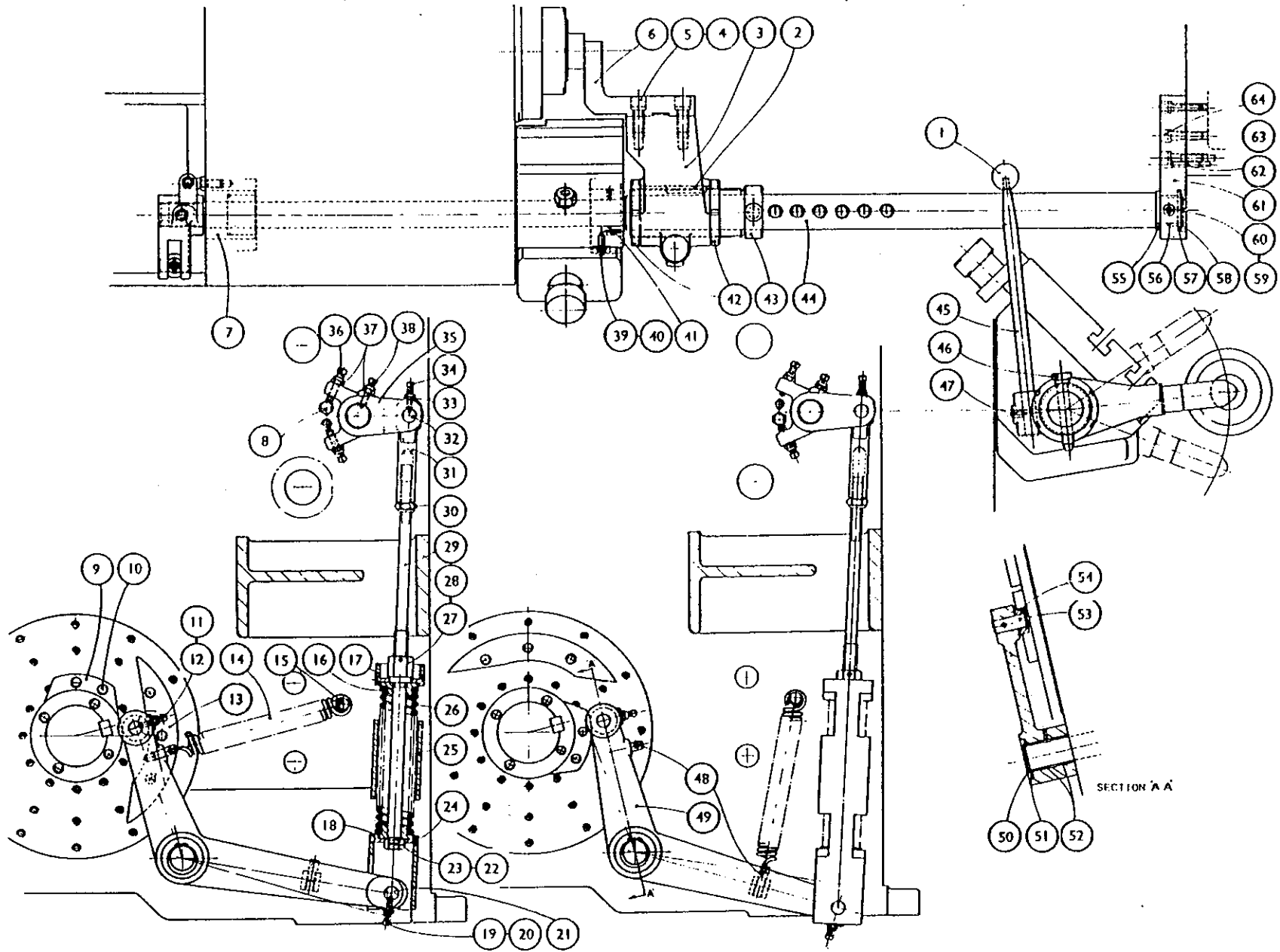

PLATE No. 42
(Drawing No. 350 Z 1)

**WICKMAN
MULTI-SPINDLE
AUTOMATICS**

**BAR STOP—REAR
2½"-6D AND 2"-6D BAR MACHINES**

INDEX NO.	PART NO.	TITLE.	INDEX NO.	PART NO.	TITLE.
1	155/0632	¾" B.S.F. Socket Head Cap Screw, 2" long.	30	351X.135	Rear Bar Stop Cam.
2	154/06	¾" Spring Washer.	31	155/0612	¾" B.S.F. Socket Head Cap Screw, ¾" long.
3	141/6	½½" dia. Taper Dowel, 1½" long.	32	173/10L	¾" B.S.F. Locknut.
4	351X.137A	Stop Shaft Bracket.	33	351X.141	Abutment (for Bar Stop Spring).
5	101/18	1½" dia. External Circlip.	34	351X.106	Bar Stop Spring.
6	122/1836T	Key, 2½" long.	35	351X.124	Spacer.
7	350V.108	Bar Stop Bracket.	36	351Y.104	Bar Stop Cam Lever.
8	154/10	¾" Spring Washer.	37	351X.117	Pivot Pin.
9	155/1024	¾" B.S.F. Socket Head Cap Screw, 1½" long.	38	351X.121	End for Bar Stop Rod.
10	350X.109	Bar Stop.	39	203/10L	¾" B.S.F. Self-Locking Nut (Thin).
11	203/06	¾" B.S.F. Self-Locking Nut.	40	351X.116	Bar Stop Operating Rod.
12	182/0620	¾" B.S.F. Socket Set Screw, Taper Point, 1½" long.	41	173/10L	¾" B.S.F. Locknut.
13	351X.114	Bush (for Bar Stop Shaft).	42	351X.124	Spacer.
14	350X.127	Locknut.	43	351V.136	Rear Bar Stop Cam.
15	350V.113	Adjusting Sleeve.	44	351X.123	Spring Anchor.
16	351Y.112	Bar Stop Shaft.	45	351X.122	Bar Stop Spring.
17	154/06	¾" Spring Washer.	46	350X.125	Spring Anchor.
18	155/0620	¾" B.S.F. Socket Head Cap Screw, 1½" long.	47	351X.120	Link Pin.
19	351V.115	Bar Stop Lever.	48	203/05	⅜" B.S.F. Self-Locking Nut.
20	350X.142	Stop Peg.	49	183/0524	⅜" B.S.F. Square Head Screw, Taper Point, 1½" long.
21	188/0628	¾" B.S.F. Square Head Screw, 1½" long.	50	124X.117	Roller.
22	203/06	¾" B.S.F. Self-Locking Nut.	51	124X.116	Roller Pin.
23	182/0516	⅝" B.S.F. Socket Set Screw, Taper Point, 1" long.	52	236/222624	Oil Retaining Bush.
24	203/05L	⅞" B.S.F. Self-Locking Nut (Thin).	53	550X.114	Locating Pin.
25	550X.126A	Adjusting Washer.	54	182/0614	¾" B.S.F. Socket Set Screw, Taper Point, ¾" long.
26	212/04	¾" B.S.F. Autolub Nipple.	55	350X.146	Feed Lever.
27	210/1725	Yellow Indicator Washer.	56	241/13	1½" dia. Black Bakelite Knob.
28	236/242816	Oil Retaining Bush.	57	351X.138	Operating Shaft Bearing.
29	550X.126A	Adjusting Washer.			

List of Parts for
PLATE No. 43
(Drawing No. 35I Z I)

WHEN ORDERING SPARE PARTS ALWAYS QUOTE THE SERIAL NUMBER OF THE MACHINE

BAR STOP—REAR
2½"-6D AND 2"-6D BAR MACHINES

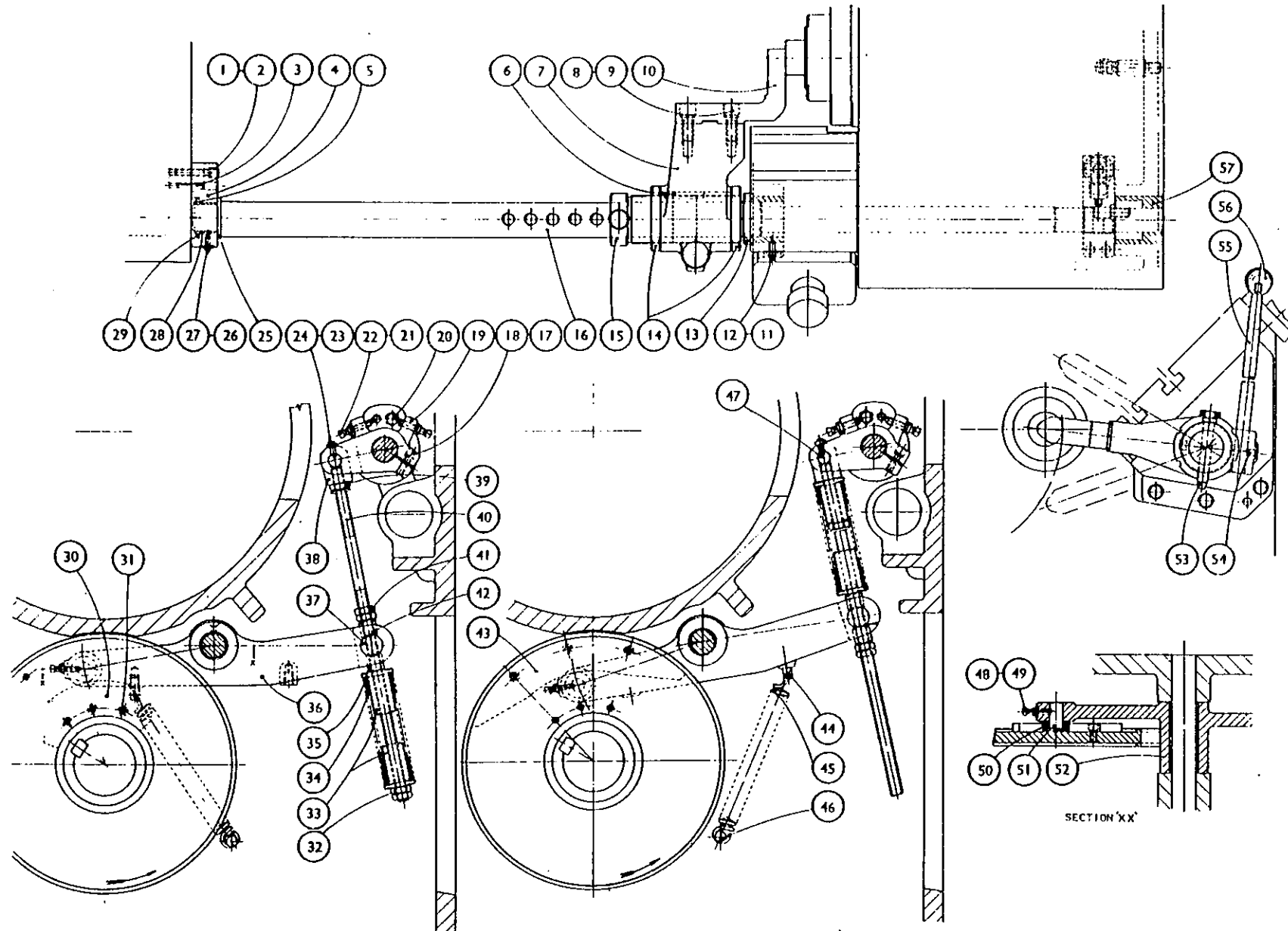

PLATE No. 43
(Drawing No. 351 Z 1)

**WICKMAN
MULTI-SPINDLE
AUTOMATICS**

AUTO STOP

2 $\frac{1}{4}$ "-6, 2 $\frac{1}{4}$ "-6D, 2"-6 AND 2"-6D (6th Station) BAR MACHINES

INDEX NO.	PART NO.	TITLE.	INDEX NO.	PART NO.	TITLE.
1	353X.144	Aligning Plate.	34	203/06L	$\frac{3}{8}$ " B.S.F. Self-Locking Nut.
2	353X.138	Stop Plate.	35	353V.132	Support Arm.
3	203/07L	$\frac{1}{8}$ " B.S.F. Self-Locking Nut.	36	203/05L	$\frac{3}{8}$ " B.S.F. Self-Locking Nut.
4	353X.168B	Spring.	37	183/0516	$\frac{1}{8}$ " B.S.F. Square Head Set Screw, 1" long.
5	353X.164	Plunger.	38	155/0510	$\frac{1}{8}$ " B.S.F. Socket Head Cap Screw, $\frac{1}{2}$ " long.
6	353Z.120	Aligning Plate Carrier.	39	154/05	$\frac{1}{8}$ " Spring Washer.
7	128/8T	$\frac{1}{2}$ " B.S.F. Pad Bush.	40	128/8T	$\frac{1}{2}$ " B.S.F. Pad Bush.
8	128/8C	$\frac{1}{2}$ " Pad Bush.	41	128/8C	$\frac{1}{2}$ " Pad Bush.
9	353X.167	Bolt.	42	167/0844	$\frac{1}{2}$ " B.S.F. Hexagon Head Screw, 2 $\frac{1}{2}$ " long.
10	212/03GS	$\frac{1}{2}$ " B.S.P. Oiler.	43	121/0828T	$\frac{1}{2}$ " Square Tapped Key, 1 $\frac{1}{2}$ " long.
11	121/0832T	$\frac{1}{2}$ " Square Tapped Key, 2" long.	44	156/408	4 B.A. Socket Head Cap Screw, $\frac{1}{2}$ " long.
12	353X.123A	Trip Lever.	45	353Y.121	Rusher Bracket.
13	353X.124	Spring Lever.	46	353X.166	Pinion.
14	353V.141	Trip Shaft.	47	353X.169	Bush.
15	125/1628	$\frac{1}{2}$ " Taper Pin, 1 $\frac{1}{2}$ " long.	48	101/4	$\frac{1}{8}$ " dia. External Circlip.
16	353X.133	Retaining Ring.	49	353X.146A	Pusher Plate.
17	150X.130	Cam Roller.	50	155/0412	$\frac{1}{2}$ " B.S.F. Socket Head Cap Screw, $\frac{3}{4}$ " long.
18	203/05L	$\frac{1}{8}$ " B.S.F. Self-Locking Nut.	51	154/04	$\frac{1}{2}$ " Spring Washer.
19	183/0514	$\frac{1}{8}$ " B.S.F. Square Head Set Screw, $\frac{1}{2}$ " long.	52	188/0752	$\frac{1}{8}$ " B.S.F. Square Head Set Screw, 3 $\frac{1}{2}$ " long.
20	353X.143	Roller Pin.	53	301X.171	Key.
21	353X.133	Retaining Ring.	54	143/1016B	$\frac{1}{8}$ " dia. Mills Grooved Pin, 1" long.
22	125/1628	$\frac{1}{2}$ " Taper Pin, 1 $\frac{1}{2}$ " long.	55	301Y.168	Feed Tube Steady.
23	353V.129	Cam Roller Bracket.	56	301Y.169	Stop Plate.
24	203/06L	$\frac{1}{2}$ " B.S.F. Self-Locking Nut.	57	101/42	4 $\frac{1}{2}$ " dia. External Circlip.
25	183/0624	$\frac{1}{2}$ " B.S.F. Square Head Set Screw, 1 $\frac{1}{2}$ " long.	58	577X.125	Plunger.
26	353X.157	Bush.	59	577X.123	Plunger Housing.
27	353X.156	Spring Sleeve.	60	558X.128	Spring.
28	353X.160	Spring.	61	577X.126	Knob.
29	353X.137	Spring Rod.	62	183/0824	$\frac{1}{2}$ " B.S.F. Square Head Set Screw, 1 $\frac{1}{2}$ " long.
30	203/08L	$\frac{1}{2}$ " B.S.F. Self-Locking Nut.	63	203/08L	$\frac{1}{2}$ " B.S.F. Self-Locking Nut.
31	183/0824	$\frac{1}{2}$ " B.S.F. Square Head Set Screw, 1 $\frac{1}{2}$ " long.	64	353X.140	Lower Guide Bar.
32	353Y.139	Guide Bar.	65	128/8T	$\frac{1}{2}$ " B.S.F. Pad Bush.
33	183/0624	$\frac{1}{2}$ " B.S.F. Square Head Set Screw, 1 $\frac{1}{2}$ " long.	66	128/8C	$\frac{1}{2}$ " Pad Bush.
			67	353X.167	Bolt.

List of Parts for
PLATE No. 44
(Drawing No. 353 Z 1)

WHEN ORDERING SPARE PARTS ALWAYS QUOTE THE SERIAL NUMBER OF THE MACHINE

AUTO STOP

2 1/4"-6, 2 1/4"-6D, 2"-6 AND 2"-6D (6th Station) BAR MACHINES

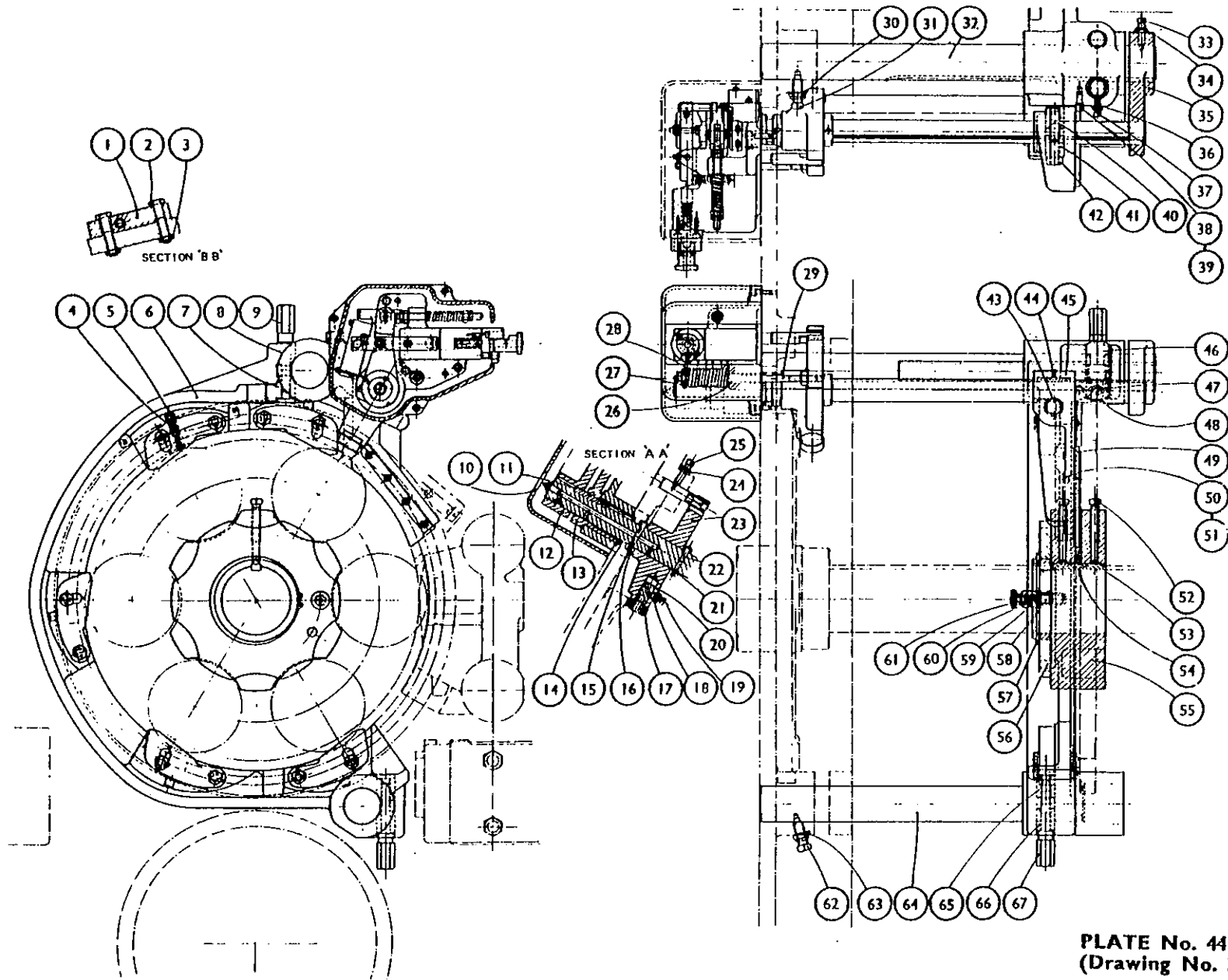
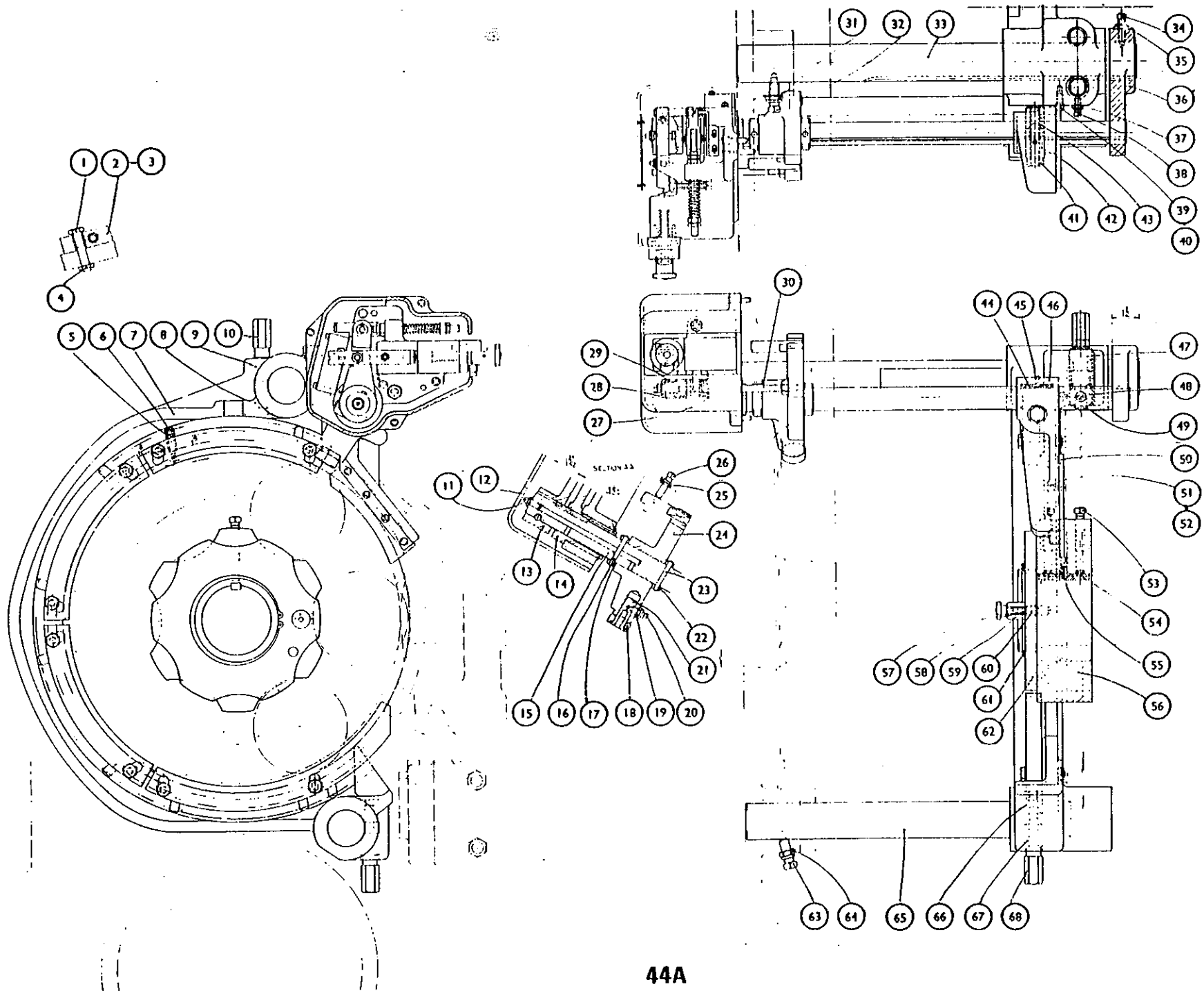

PLATE No. 44
(Drawing No. 353 Z 1)

INDEX NO.	PART NO.	TITLE	INDEX NO.	PART NO.	TITLE
1	353X.138	Stop Bolt.	35	203/06L	¾" B.S.F. Self Lock Locknut.
2	353V.170A	Aligning Plate.	36	353V.132	Support Arm.
3	353V.171	Aligning Plate 1st Station.	37	203/05L	⅜" B.S.F. Self Lock Locknut.
4	203/07L	⅞" B.S.F. Self Lock Locknut.	38	183/0516	⅞" B.S.F. Square Head Set Screw 1" long.
5	353X.168C	Spring.	39	155/0510	⅞" B.S.F. Cap Screw ¾" long.
6	353X.164	Plunger.	40	154/05	⅞" Spring Washer.
7	353Z 12013	Aligning Plate Carrier.	41	167/0844	½" B.S.F. Hexagon Head Screw 2½" long.
8	128/11T	½" B.S.F. Pad Bush 1" o/d × 1½" long.	42	128/8C	½" Pad Bush 1" o/d × 1½" long.
9	128/8C	½" Pad Bush 1" o/d × 1½" long.	43	128/8T	½" B.S.F. Pad Bush 1" o/d × 1½" long.
10	353X.167	Bolt.	44	121/0828T	Key ¼" square × 1½" long.
11	212/0365	½" B.S.P. Oiler.	45	156/408	4 B.A. Cap Screw ½" long.
12	121/0832T	Key ¼" square × 2" long.	46	353Y.121	Pusher Bracket.
13	353X.123A	Trip Lever.	47	353X.166	Pinion.
14	353X.124	Spring Lever.	48	353X.169	Bush.
15	353X.141	Trip Shaft.	49	101/4	¾" External Circlip.
16	125/1628	Taper Pin ¼" dia. × 1½" long	50	353X.146A	Pusher Plate.
17	353X.133	Retaining Ring.	51	155/0412	½" B.S.F. Cap Screw ¾" long.
18	150X.130	Cam Roller.	52	154/04	½" Spring Washer.
19	203/05L	⅞" B.S.F. Self Lock Locknut.	53	188/0752	Square Head Set Screw ⅞" × 3¼" long.
20	183/0514	⅞" B.S.F. Square Head Set Screw ¾" long.	54	301X.171	Key.
21	353X.143	Roller Pin.	55	143/1016B	Grooved Pin ⅞" dia. × 1" long.
22	353X.133	Retaining Ring.	56	301Y.168	Feed Tube Steady.
23	125/1628	Taper Pin ¼" × 1½" long.	57	577X.126	Knob.
24	353V.129	Cam Roller Bracket.	58	558X.128	Spring.
25	203/06L	¾" B.S.F. Self Lock Locknut.	59	577X.123	Plunger Housing.
26	183/0624	¾" B.S.F. Square Head Set Screw 1½" long.	60	577X.125	Plunger.
27	353X.157	Bush.	61	101/42	External Circlip for 4½" dia. Shaft.
28	353X.156	Spring Sleeve.	62	301Y.169	Stop Plate.
29	353X.160	Spring.	63	183/0824	½" B.S.F. Square Head Set Screw 1½" long.
30	353X.137	Spring Rod.	64	203/08L	½" B.S.F. Self Lock Locknut.
31	203/08L	½" B.S.F. Self Lock Locknut.	65	353X.140	Lower Guide Bar.
32	183/0824	½" B.S.F. Square Head Set Screw 1½" long.	66	128/8T	½" B.S.F. Pad Bush 1" o/d × 1½" long.
33	353Y.139	Upper Guide Bar.	67	128/8C	½" Pad Bush 1" o/d × 1½" long.
34	183/0624	¾" B.S.F. Square Head Set Screw 1½" long.	68	353X.167	Bolt.

List of Parts for
PLATE No. 44A
(Drawing No. 353Z1A)

WHEN ORDERING SPARE PARTS ALWAYS QUOTE THE SERIAL NUMBER OF THE MACHINE



**WICKMAN
MULTI-SPINDLE
AUTOMATICS**

AUTO STOP

2¼"-6, 2¼"-6D, 2"-6 AND 2"-6D (3rd Station) BAR MACHINES

INDEX NO.	PART NO.	TITLE.
1	155/0516	⅜" B.S.F. Socket Head Cap Screw, 1" long.
2	154/05	⅜" Spring Washer.
3	167/0728	⅜" B.S.F. Hexagon Head Screw, 1½" long.
4	203/07	⅞" B.S.F. Self-Locking Nut.
5	130/05	⅜" Flat Washer.
6	127/04u5	⅜" Cotter Pin.
7	120X.112	Striker Pln.
8	153X.166	Trip Screw.
9	203/05L	⅜" B.S.F. Self-Locking Nut.
10	153X.147A	Trip Lever.
11	176/0410	½" B.S.F. Socket Set Screw, ½" long.
12	203/04	½" B.S.F. Self-Locking Nut.
13	145/146	Compression Spring.
14	158X.124A	Plunger.
15	153X.148	Trip Plunger.
16	153X.152	Latch Spring.
17	153X.135B	Latch Disc.
18	156/210	2 B.A. Socket Head Cap Screw, ½" long.
19	154/03	⅜" Spring Washer.
20	125/0814	½" Taper Pin, ½" long.
21	153X.136B.	Latch Knob.
22	198/6	2 B.A. Internal Shakeproof Washer.
23	130/03	⅜" Flat Washer.
24	156/206	2 B.A. Socket Head Cap Screw, ½" long.
25	153X.167	Stop.
26	141/4	⅝" dia. Taper Dowel, 1½" long.

(Drawing No. 153 Z 2B)

INDEX NO.	PART NO.	TITLE.
1	168/420	4 B.A. Hexagon Head Screw, 1½" long.
2	—	4 B.A. Flat Washer.
3	4 BR. MS.	Micro-Switch.
4	153X.149	Pin.
5	173/06L	¾" B.S.F. Hexagon Locknut.
6	173/06	¾" B.S.F. Hexagon Nut.
7	MSC.175	Morris Spring.
8	173/06	¾" B.S.F. Hexagon Nut.
9	173/06L	¾" B.S.F. Hexagon Locknut.
10	153X.134	Spring Rod.
11	153X.165	Stop Screw.
12	153Y.122	Trip Bracket.
13	155/0536	⅜" B.S.F. Socket Head Cap Screw, 2¼" long.
14	154/05	⅜" Spring Washer.
15	141/4	⅝" Taper Dowel, 1½" long.

(Drawing No. 153 Z 1B)

AUTO STOP

2 1/4"-6, 2 1/4"-6D, 2"-6 AND 2"-6D (3rd Station) BAR MACHINES

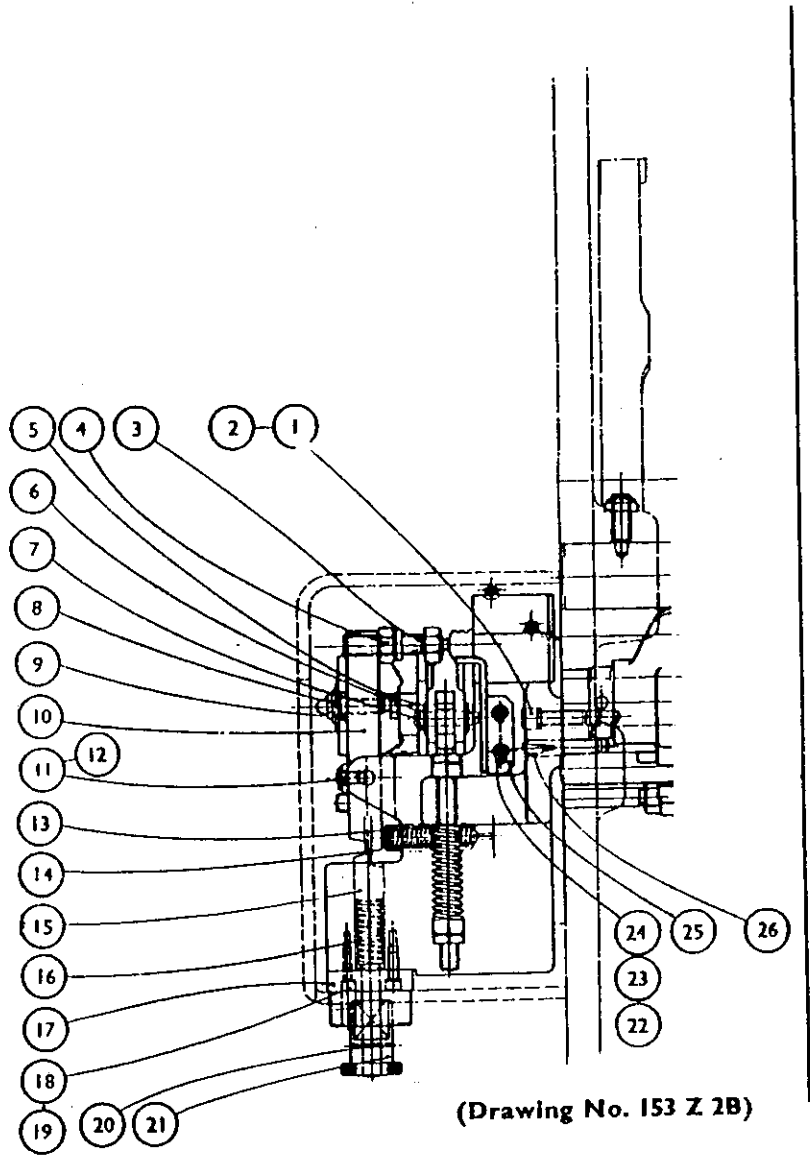

(Drawing No. 153 Z 2B)

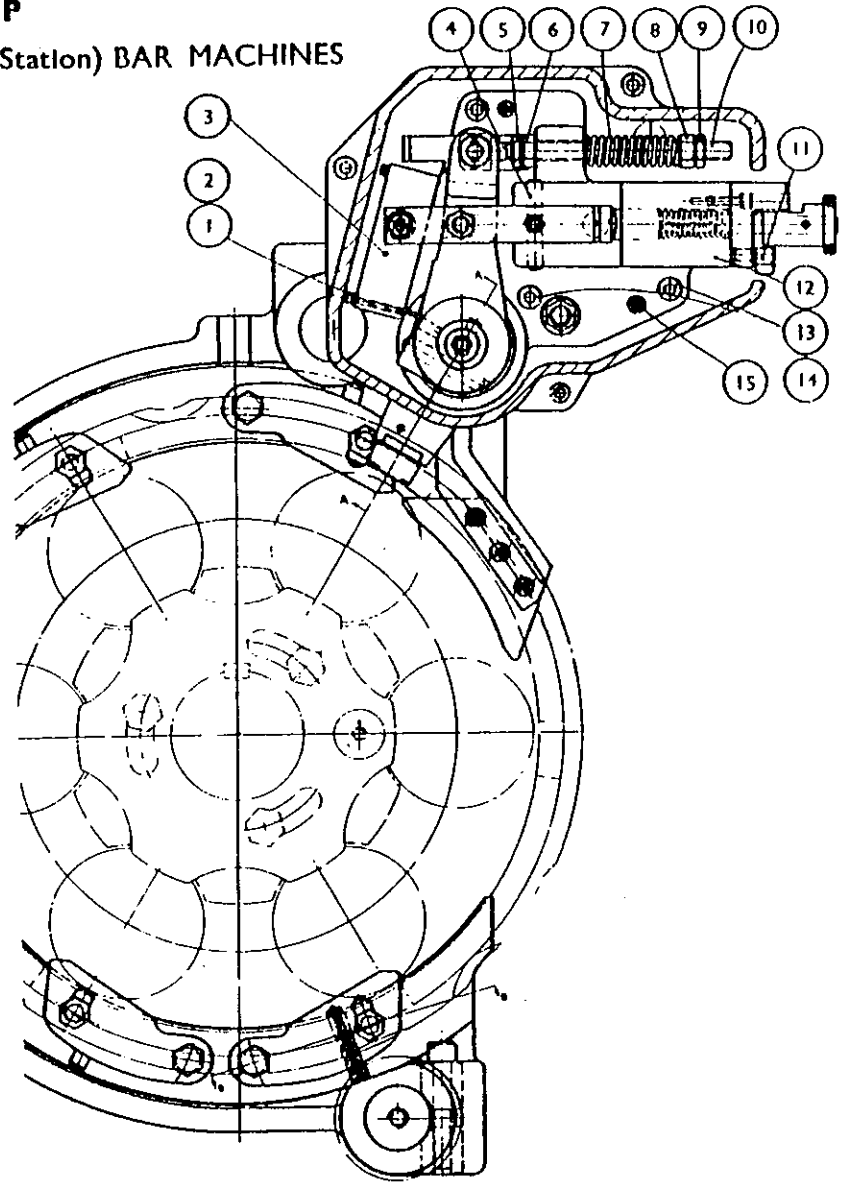

(Drawing No. 153 Z 1B)

**AUTO STOP
2½"-6D AND 2"-6D CHUCKING MACHINES**

INDEX NO.	PART NO.	TITLE.	INDEX NO.	PART NO.	TITLE.
1	354Z120/1	Aligning Plate Carrier, (Upper).	16	354V.139	Guide Bar
2	125/2622	½" dia. Taper Pin, 1½" long.	17	354Z.120/2	Aligning Plate Carrier, (Lower).
3	155/0616	½" B.S.F. Socket Head Cap Screw, 1" long.	18	155/0616	½" B.S.F. Socket Head Cap Screw, 1" long.
4	154/06	½" Spring Washer.	19	154/06	½" Spring Washer.
5	354V.139	Guide Bar.	20	125/2622	½" dia. Taper Pin, 1½" long.
6	354X.127	Key.	21	143/1038D	⅜" Mills Pin, 1½" long.
7	155/0410	½" B.S.F. Socket Head Cap Screw, ½" long.	22	121/0828T	Key, ½" square, 1½" long.
8	354V.131	Trip Shaft.	23	156/408	4 B.A. Socket Head Cap Screw, ½" long.
9	155/0520	⅜" B.S.F. Socket Head Cap Screw, 1½" long.	24	353X.167	Bolt.
10	154/05	⅜" Spring Washer.	25	128/8C	½" Pad Bush.
11	125/2224	½" dia. Taper Pin, 1½" long.	26	128/8T	½" B.S.F. Pad Bush.
12	354X.126	Support Block.	27	155/0412	½" B.S.F. Socket Head Cap Screw, ½" long.
13	155/0416	½" B.S.F. Socket Head Cap Screw, 1" long.	28	154/04	½" Spring Washer.
14	154/04	½" Spring Washer.	29	353X.146A	Pusher Plate.
15	154Y.128	Cover, (for Trip Bracket).	30	354Y.125	Pusher Bracket.

List of Parts for
PLATE No. 46
(Drawing No. 354 Z I)

WHEN ORDERING SPARE PARTS ALWAYS QUOTE THE SERIAL NUMBER OF THE MACHINE

AUTO STOP
2½"-6D AND 2"-6D BAR MACHINES

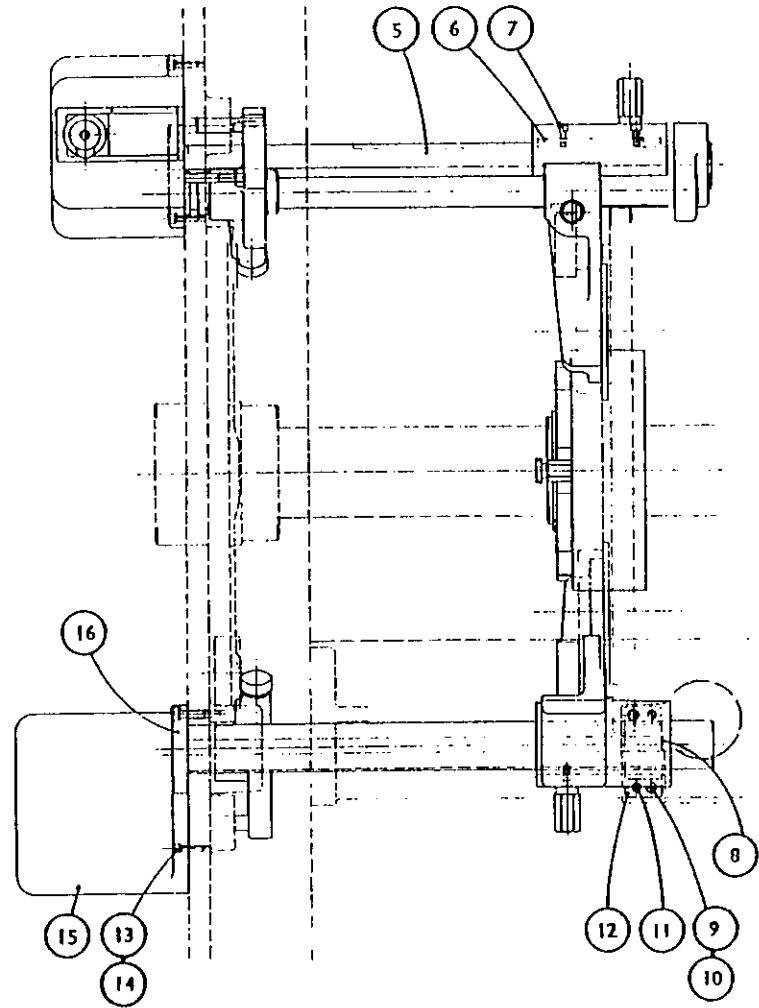
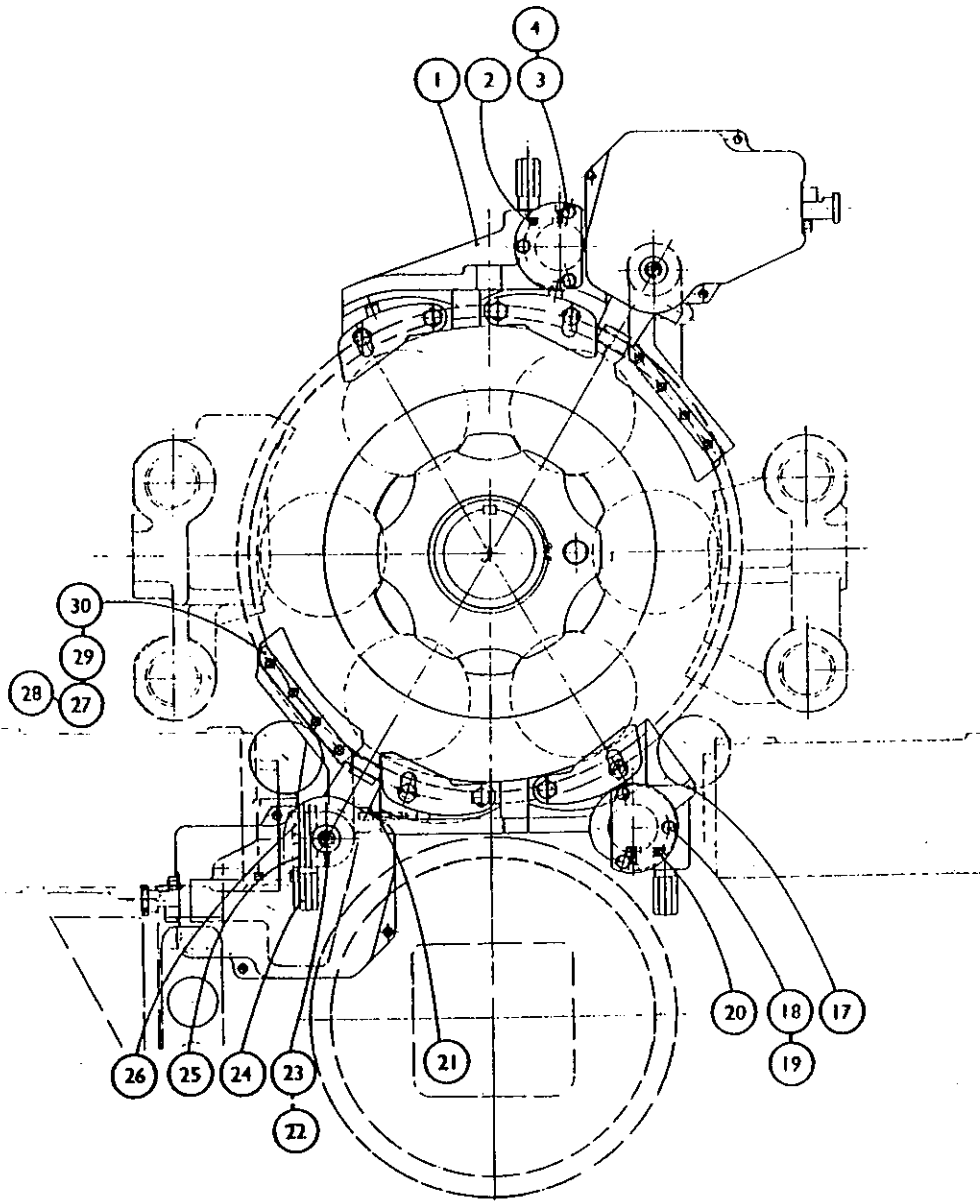

PLATE No. 46
(Drawing No. 354 Z 1)

**WICKMAN
MULTI-SPINDLE
AUTOMATICS**

AUTO STOP – STATION 3

2" -6D, 2¼" -6D BAR MACHINES

INDEX NO.	PART NO.	TITLE	INDEX NO.	PART NO.	TITLE
1	354Z.120B/1	Aligning Plate Carrier (Upper)	17	125/2622	Taper Pin 13/32" dia. x 1½" long
2	125/2622	Taper Pin 13/32" dia. 1½" long	18	155/0616	¾" B.S.F. Cap Screw 1" long
3	154/06	Spring Washer	19	354Z.120B/2	Aligning Plate Carrier (Lower)
4	155/0616	¾" B.S.F. Cap Screw 1" long	20	154/06	Spring Washer
5	354V.139	Guide Bar	21	143/1028D	Grooved Pin 5/16" dia. 1½" long
6	354X.127	Key	22	158/408	4 B.A. Cap Screw ½" long
7	155/0410	½" B.S.F. Cap Screw ¾" long	23	121/0828T	Key ¼" square 1¼" long
8	354V.131	Trip Shaft	24	353X.167	Bolt
9	155/0528	5/16" B.S.F. Cap Screw 1¼" long	25	128/8C	Pad Bush
10	154/05	Spring Washer	26	128/8T	Pad Bush
11	354X.126A	Support Block	27	154/04	Spring Washer
12	155/0416	½" B.S.F. Cap Screw 1" long	28	155/0412	½" B.S.F. Cap Screw ¾" long
13	154/04	Spring Washer	29	353X.146A	Pusher Plate
14	154Y.128	Cover	30	354Y.125	Pusher Bracket
15	354V.139	Guide Bar	31	353V.171	Aligning Plate – 1st Station
16	353V.171	Aligning Plate – 1st Station			

List of Parts for
PLATE No.46 A
(Drawing No.35421A)

WHEN ORDERING SPARE PARTS ALWAYS QUOTE THE SERIAL NUMBER OF THE MACHINE

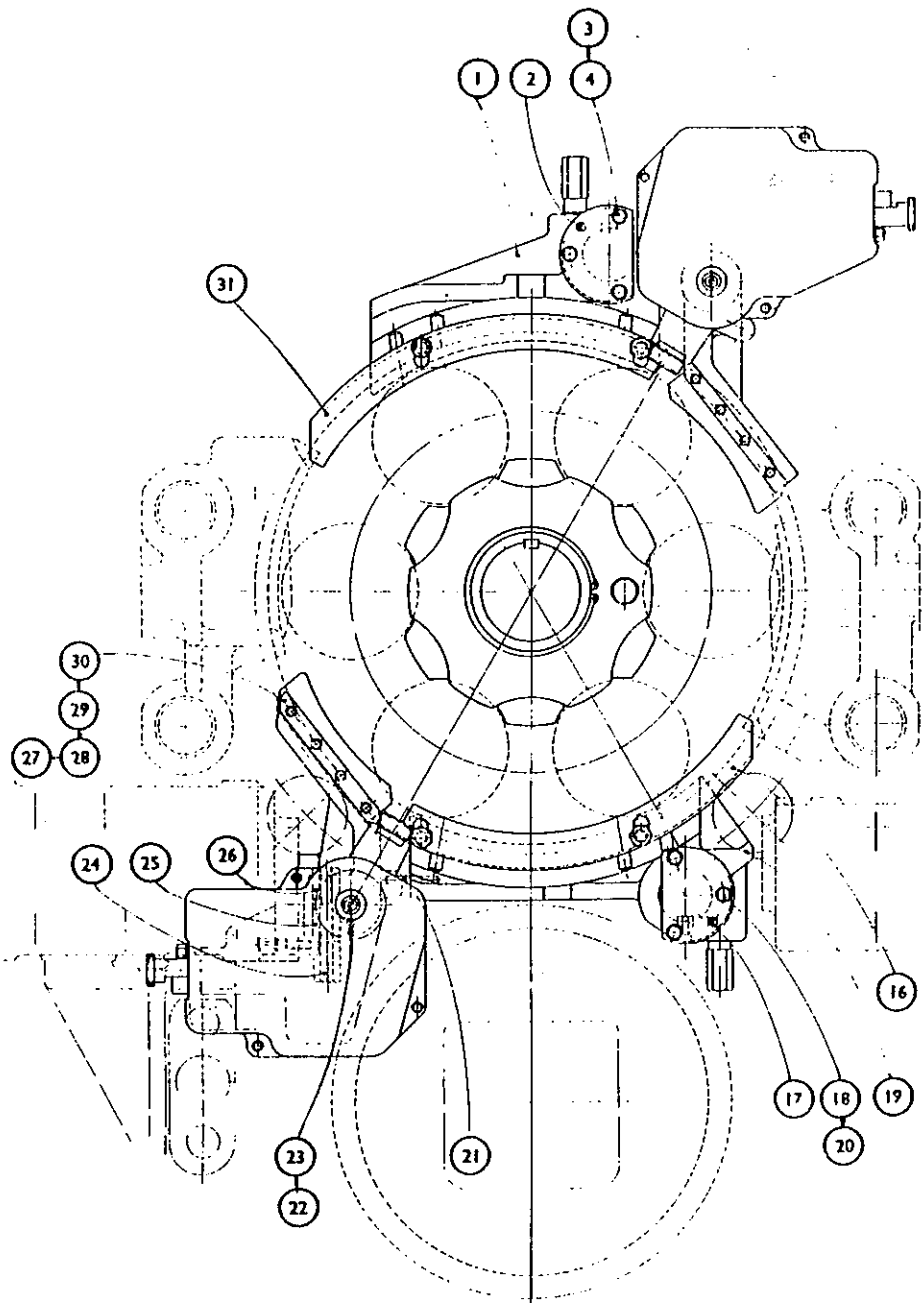

46A

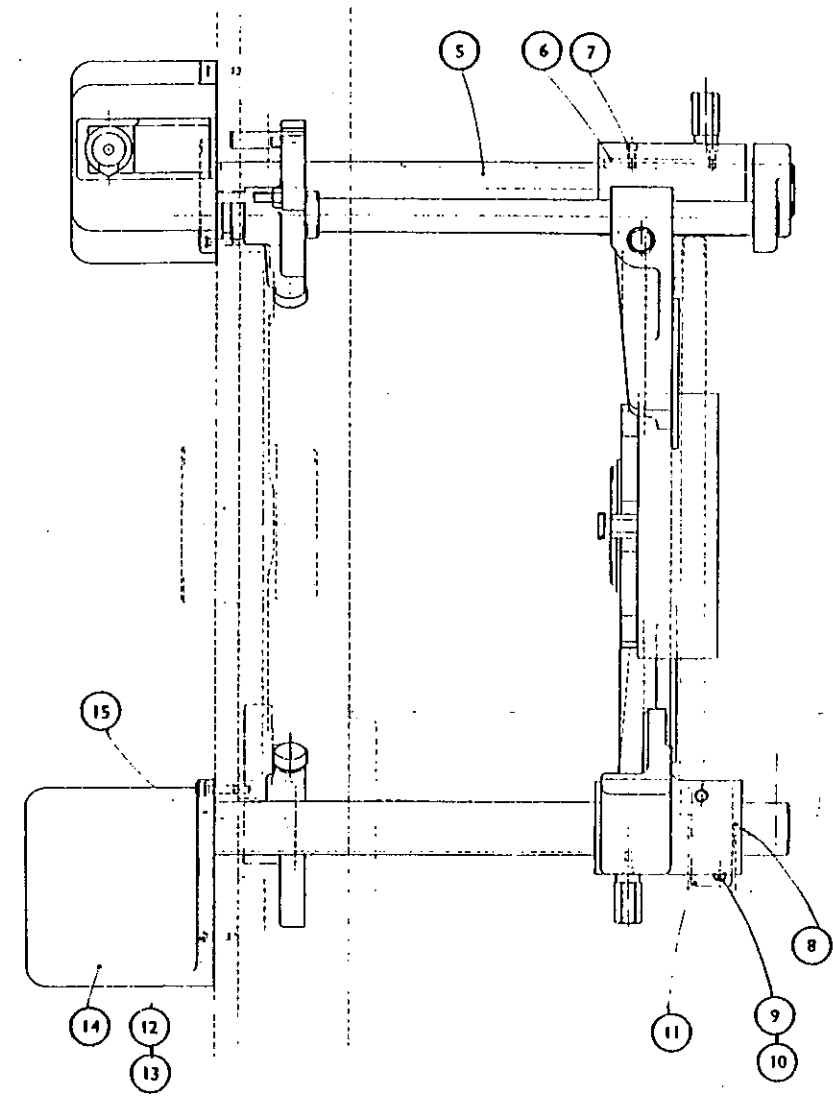

354 Z 1A

**WICKMAN
MULTI-SPINDLE
AUTOMATICS**

COLLET OPERATION

2¼"-6, 2¼"-6D, 2"-6 AND 2"-6D BAR MACHINES

INDEX NO.	PART NO.	TITLE.	INDEX NO.	PART NO.	TITLE.
1	356X.133	Eccentric Pin.	35	256X.142A	Link (2¼"-6D and 2"-6D only).
2	236/202414	Oil Retaining Bush.	36	356X.142A	Link (2¼"-6 and 2"-6 only).
3	155/0824	½" B.S.F. Socket Head Cap Screw, 1½" long.	37	356X.136	Hand Operation Lever.
4	154/08	½" Spring Washer.	38	212/18	½" B.S.P. Oiler.
5	183/0632	½" B.S.F. Square Head Set Screw, 2" long.	39	210/2525	Yellow Indicator Washer.
6	203/06L	½" B.S.F. Self-Locking Nut.	40	155/0828	½" B.S.F. Socket Head Cap Screw, 1½" long.
7	356X.132	Link Pin.	41	154/08	½" Spring Washer.
8	101/15	1½" dia. External Circlip.	42	183/0624	½" B.S.F. Square Head Set Screw, 1½" long.
9	236/202414	Oil Retaining Bush.	43	203/06L	½" B.S.F. Self-Locking Nut.
10	356X.110	Shoe Pin.	44	356Y.105	Collet Operating Lever.
11	203/04L	½" B.S.F. Self-Locking Nut.	45	212/18	½" B.S.P. Oiler.
12	183/0416	½" B.S.F. Square Head Set Screw, 1" long.	46	210/2525	Yellow Indicator Washer.
13	356X.137	Handle.	47	356V.109	Pivot Shaft.
14	356X.130	Eccentric Plate.	48	212/03GS	½" B.S.P. Oiler.
15	212/4518	½" B.S.P. Oiler.	49	210/2525	Yellow Indicator Washer.
16	210/2525	Yellow Indicator Washer.	50	236/242828	Oil Retaining Bush.
17	356Z.101	Collet Operating Slide.	51	356V.135	Shaft (Hand Operation to Collet).
18	236/323640	Oil Retaining Slide.	52	356X.140	Link Pin (Hand Operation to Collet).
19	356X.104	Collet Operating Link (2¼"-6 and 2"-6 only).	53	101/9	½" External Circlip.
20	356X.191	Collet Operating Link (2¼"-6D and 2"-6D only).	54	203/04L	½" B.S.F. Self-Locking Nut.
21	356X.190	Stop Collar.	55	183/0420	½" B.S.F. Square Head Set Screw, 1½" long.
22	236/323640	Oil Retaining Bush.	56	356X.141	Link Pin.
23	356X.190	Stop Collar (2¼"-6D and 2"-6D only).	57	358X.107	Roller Pin.
24	14.02.406	Copper Tube, 12" long	58	358X.112	Cam Roller.
25	14.07.04	4mm Tubing Nut	59	236/242828	Oil Retaining Bush.
26	14.08.04	4mm Tubing Sleeve	60	356V.113	Collet Operating Shoe.
27	14.75.0402	4mm Male Elbow	61	143/1048B	⅜" Mills Grooved Pin, 3" long.
28	203/06L	½" B.S.F. Self-Locking Nut.	62	356X.110	Shoe Pin.
29	183/0620	½" B.S.F. Square Head Set Screw, 1½" long.	63	183/0420	½" B.S.F. Square Head Set Screw, 1½" long.
30	203/06L	½" B.S.F. Self-Locking Nut.	64	203/04L	½" B.S.F. Self-Locking Nut.
31	183/0620	½" B.S.F. Square Head Set Screw, 1½" long.	65	356X.139	Plunger.
32	14.07.04	4mm Tubing Sleeve	66	145/176	Compression Spring.
33	14.08.04	4mm Tubing Nut	67	356X.138	Spring Retaining Plug.
34	14.75.0402	4mm Male Elbow			

List of Parts for
PLATE No. 47
(Drawing No. 356 Z I)

WHEN ORDERING SPARE PARTS ALWAYS QUOTE THE SERIAL NUMBER OF THE MACHINE

COLLET OPERATION
 2 1/4"-6, 2 1/4"-6D, 2"-6 AND 2"-6D BAR MACHINES

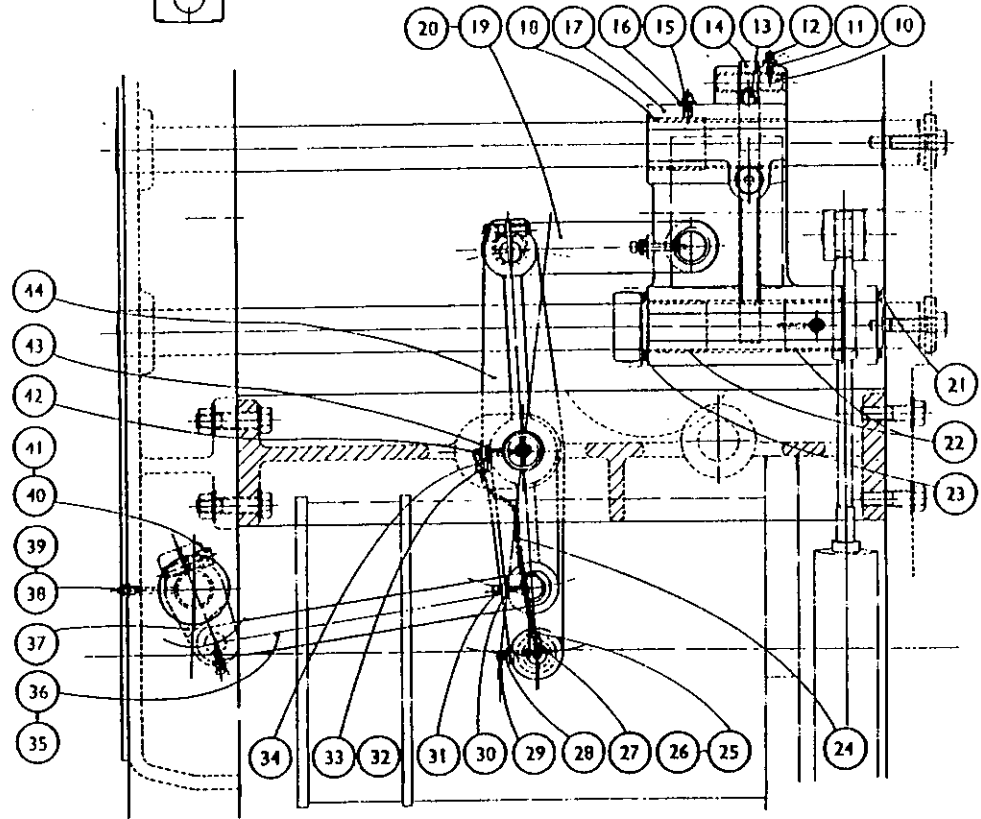
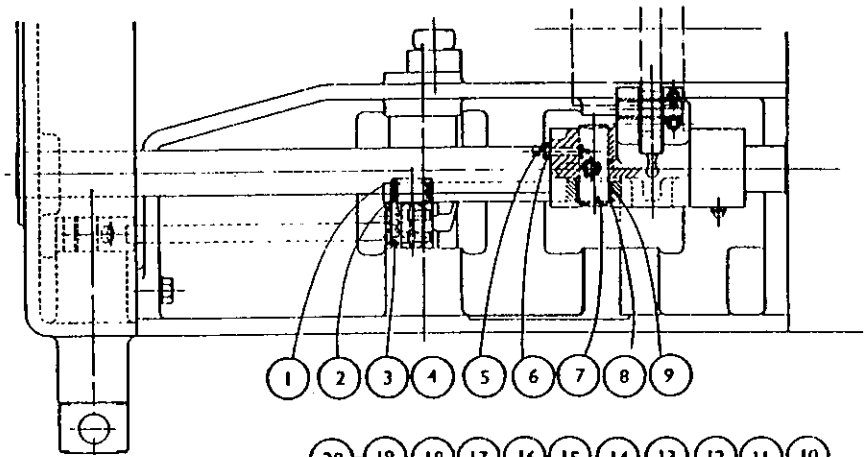
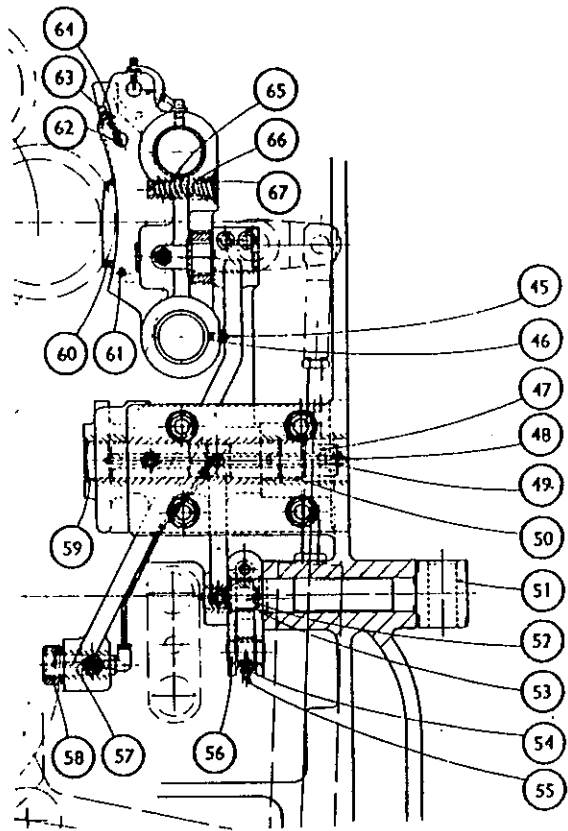

PLATE No. 47
(Drawing No. 356 Z I)

**WICKMAN
MULTI-SPINDLE
AUTOMATICS**

**COLLET OPERATION
2 $\frac{1}{4}$ "-6D, AND 2"-6D (3rd Station) BAR MACHINES**

INDEX NO.	PART NO.	TITLE.	INDEX NO.	PART NO.	TITLE.
1	203/04L	$\frac{1}{2}$ " B.S.F. Self-Locking Nut.	35	14.08.04	4mm Tubing Sleeve
2	183/0416	$\frac{1}{2}$ " B.S.F. Square Head Set Screw, 1" long.	36	356X.136	Hand Operation Lever.
3	356X.130	Eccentric Plate.	37	210/2525	Yellow Indicator Washer.
4	356X.137	Handle.	38	212/18	$\frac{1}{2}$ " B.S.P. Oiler.
5	356X.110	Shoe Pin.	39	155/0328	$\frac{1}{2}$ " B.S.F. Socket Head Cap Screw, 1 $\frac{1}{2}$ " long.
6	356X.132	Link Pin.	40	154/08	$\frac{1}{2}$ " Spring Washer.
7	101/15	1 $\frac{1}{2}$ " dia. External Circlip.	41	357X.142A	Link.
8	236/202414	Oil Retaining Bush.	42	356Y.105	Collet Operating Lever.
9	20./06L	$\frac{1}{2}$ " B.S.F. Self-Locking Nut.	43	356X.139	Plunger.
10	183/0632	$\frac{1}{2}$ " B.S.F. Square Head Set Screw, 2" long.	44	356X.138	Spring Retaining Plug.
11	155/0824	$\frac{1}{2}$ " B.S.F. Socket Head Cap Screw, 1 $\frac{1}{2}$ " long.	45	145/176	Compression Spring.
12	154/08	$\frac{1}{2}$ " Spring Washer.	46	210/2525	Yellow Indicator Washer.
13	356X.133	Eccentric Pin.	47	212/18	$\frac{1}{2}$ " B.S.P. Oiler.
14	236/202414	Oil Retaining Bush.	48	236/242828	Oil Retaining Bush.
15	357X.105	Spacing Piece.	49	356V.109	Pivot Shaft.
16	357X.104	Collet Operating Link.	50	210/2525	Yellow Indicator Washer.
17	357Z.101	Collet Operating Slide (Rear).	51	212/03G5	$\frac{1}{2}$ " B.S.P. Oiler.
18	236/323632	Oil Retaining Bush.	52	356V.135	Shaft (Hand Operation to Collet)
19	210/2525	Yellow Indicator Washer.	53	101/9	$\frac{7}{8}$ " dia. External Circlip.
20	212/4518	$\frac{1}{2}$ " B.S.P. Oiler.	54	356X.140	Link Pin (Hand Operation to Collet).
21	356X.190	Stop Collar.	55	356X.141	Link Pin.
22	236/323640	Oil Retaining Bush.	56	203/04L	$\frac{1}{2}$ " B.S.F. Self-Locking Nut.
23	183/0624	$\frac{1}{2}$ " B.S.F. Square Head Set Screw, 1 $\frac{1}{2}$ " long.	57	183/0420	$\frac{1}{2}$ " B.S.F. Square Head Set Screw, 1 $\frac{1}{2}$ " long.
24	203/06L	$\frac{1}{2}$ " B.S.F. Self-Locking Nut.	58	358X.107	Roller Pin.
25	14.76.0402	4mm Male Elbow	59	358X.112	Cam Roller.
26	14.07.04	4mm Tubing Nut	60	236/242828	Oil Retaining Bush.
27	14.08.04	4mm Tubing Sleeve	61	143/1048B	$\frac{1}{8}$ " Mills Grooved Pin, 3" long.
28	14.02.406	Copper Tube, 12" long	62	356V.113	Collet Operating Shoe.
29	183/0620	$\frac{1}{2}$ " B.S.F. Square Head Set Screw, 1 $\frac{1}{2}$ " long.	63	183/0420	$\frac{1}{2}$ " B.S.F. Square Head Set Screw, 1 $\frac{1}{2}$ " long.
30	203/06L	$\frac{1}{2}$ " B.S.F. Self-Locking Nut.	64	203/04L	$\frac{1}{2}$ " B.S.F. Self-Locking Nut.
31	183/0620	$\frac{1}{2}$ " B.S.F. Square Head Set Screw, 1 $\frac{1}{2}$ " long.	65	356X.110	Shoe Pin.
32	203/06L	$\frac{1}{2}$ " B.S.F. Self-Locking Nut.	66	357X.151	Drum Locking Rod (Upper).
33	14.76.0402	4mm Male Elbow	67	357X.150	Lever.
34	14.07.04	4mm Tubing Nut			

List of Parts for
PLATE No. 48
(Drawing No. 357 Z 1)

WHEN ORDERING SPARE PARTS ALWAYS QUOTE THE SERIAL NUMBER OF THE MACHINE

COLLET OPERATION

2 1/4"-6D, AND 2"-6D (3rd Station) BAR MACHINES

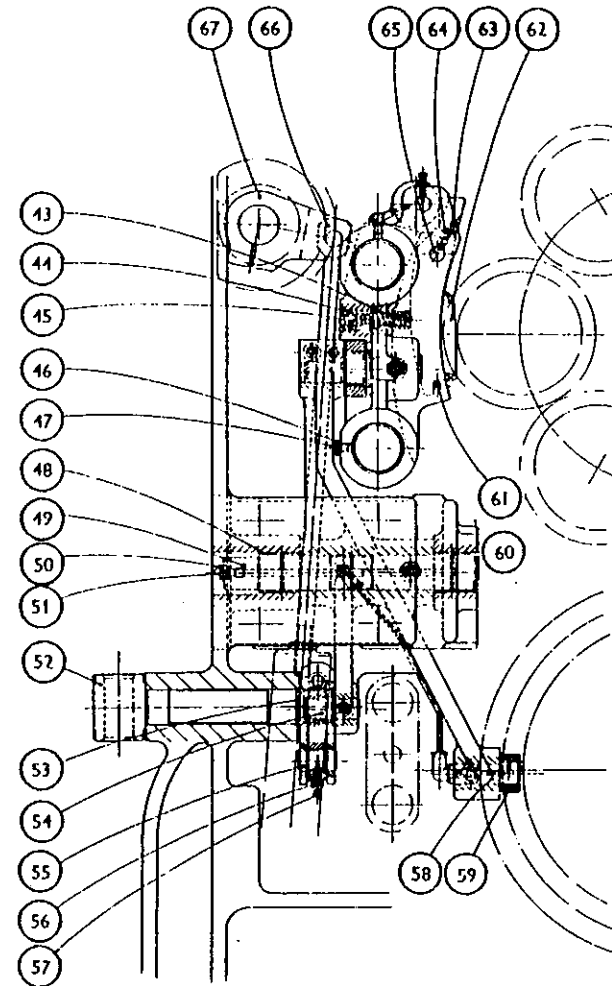
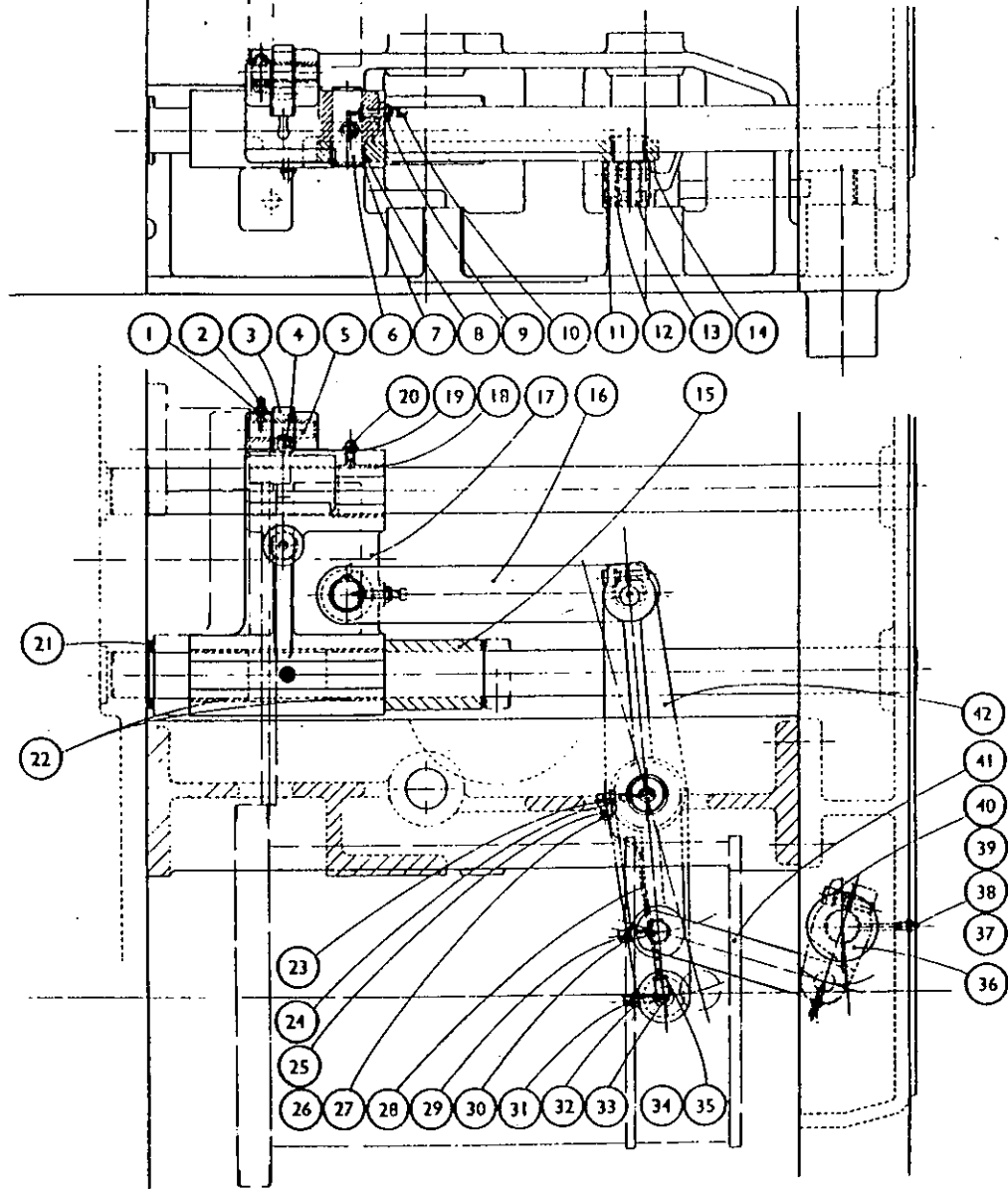

**WICKMAN
MULTI-SPINDLE
AUTOMATICS**

BAR FEED

2 1/4"-6, 2 1/4"-6D, 2"-6 AND 2"-6D CHUCKING MACHINES

INDEX NO.	PART NO.	TITLE.	INDEX NO.	PART NO.	TITLE.	INDEX NO.	PART NO.	TITLE.
1	203/14L	3/8" B.S.F. Self-Locking Nut.	41	358X.157	Guide Bar.	81	183/0624	3/8" B.S.F. Square Head Set Screw, 1 1/2" long.
2	236/202424	Oil Retaining Bush.	42	358X.164	Eccentric Roller Pin.	82	203/06L	3/8" B.S.F. Self-Locking Nut.
3	358V.127	Link Pivot.	43	130/14	7/8" Flat Washer.	83	358X.162	Stop Collar.
4	358X.108	Pivot Bolt.	44	173/14LH	3/8" B.S.F. Hexagon Locknut.	84	236/323640	Oil Retaining Bush.
5	188/0524	1/8" B.S.F. Square Head Set Screw, 1 1/2" long.	45	210/2525	Yellow Indicator Washer.	85	125/3248	3/8" Taper Pin, 3" long.
6	236/242828	Oil Retaining Bush.	46	212/03GS	1/2" B.S.P. Oiler.	86	101/22	2" External Circlip.
7	101/9	3/8" External Circlip.	47	358Z.195	Connecting Bridge, Front (2"-6D only)	87	167/1032	3/8" B.S.F. Hexagon Head Screw, 2" long.
8	236/141820	Oil Retaining Bush.	48	358Z.103A	Connecting Bridge (2"-6 only).	88	198/18	3/8" Shakeproof Washer.
9	358X.160	Link Pin.	49	170/1044	3/8" B.S.F. Hexagon Head Bolt, 2 1/4" long.	89	358X.117	Guide Washer.
10	194/1	1/2" B.S.P. Plug.	50	173/10	1/2" B.S.P. Hexagon Nut.	90	358Z.196	Bar Feed Lever, Front (2"-6D only).
11	358X.107	Roller Pin.	51	198/18	3/8" Shakeproof Washer.	91	358Z.104	Bar Feed Lever (2"-6 only).
12	358X.112	Cam Roller.	52	130/10	7/8" Flat Washer.	92	210/2525	Yellow Indicator Washer.
13	356V.109	Pivot Shaft.	53	CT.685	Oil Retaining Bush.	93	212/4518	1/2" B.S.P. Oiler.
14	358V.105A	Bar Feed Pusher Plate.	54	155/0620	1/2" B.S.F. Socket Head Cap Screw, 1 1/2" long.	94	358Y.197	Bar Feed Scale, Front (2"-6D only).
15	203/05L	3/8" B.S.F. Self-Locking Nut.	55	154/06	3/8" Spring Washer.	95	358Y.109	Bar Feed Scale, (2"-6 only).
16	236/242828	Oil Retaining Bush.	56	358X.155	Retaining Plate.	96	165/206	2 B.A. Round Head Screw, 3/8" long.
17	154/04	3/8" Spring Washer.	57	358X.151	Spring Stud.	97	358V.119	Bar Feed Link (2"-6 only).
18	155/0410	1/2" B.S.F. Socket Head Cap Screw, 1 1/2" long.	58	358X.120A	Locknut.	98	358X.198	Link (2"-6D only).
19	210/2525	Yellow Indicator Washer.	59	CT.685	Oil Retaining Bush.	99	358X.167	Pin (2"-6 only).
20	212/03GS	1/2" B.S.P. Oiler.	60	358X.153	Pressure Plate.	100	183/0528	3/8" B.S.F. Square Head Set Screw, 1 1/2" long.
21	203/05L	3/8" B.S.F. Self-Locking Nut.	61	358X.120A	Locknut.	101	203/05L	3/8" B.S.F. Self-Locking Nut.
22	182/0520	3/8" B.S.F. Socket Set Screw, 1 1/2" long.	62	183/0632	1/2" B.S.F. Square Head Set Screw, 2" long.	102	178/0514	3/8" B.S.F. Socket Set Screw, 3/8" long.
23	210/2525	Yellow Indicator Washer.	63	203/06L	3/8" B.S.F. Self-Locking Nut.	103	358X.170	Spring (2"-6 only).
24	212/18	1/2" B.S.P. Oiler.	64	203/12L	3/8" B.S.F. Self-Locking Nut.	104	358X.168	Plunger (2"-6 only).
25	558X.129A	Spring.	65	14.07.04	4mm Tubing Nut	105	236/323640	Oil Retaining Bush.
26	558X.124A	Spring Plunger.	66	14.08.04	4mm Tubing Sleeve	106	358X.169	Plunger Seating (2"-6 only).
27	101/15	1 1/2" dia. External Circlip.	67	358X.165	Connecting Block.	107	358Y.166	Link Body (2"-6 only).
28	236/202424	Oil Retaining Bush (2"-6D only).	68	14.75.0402	4mm Male Elbow	108	558X.126B	Plunger.
29	236/202416	Oil Retaining Bush (2"-6 only).	69	203/06L	3/8" B.S.F. Self-Locking Nut.	109	210/2525	Yellow Indicator Washer.
30	358X.199	Link Pivot (2"-6D only).	70	183/0640	1/2" B.S.F. Square Head Set Screw, 2 1/2" long.	110	212/4518	1/2" B.S.P. Oiler.
31	358X.123	Link Pivot (2"-6 only).	71	225/3050	Copper Tube, 16" long.	111	558X.127A	Knob.
32	155/0616	1/2" B.S.F. Socket Head Cap Screw, 1" long.	72	358X.161	Spring.	112	558X.128	Spring.
33	154/06	3/8" Spring Washer.	73	358X.152	Spring Guide.	113	558X.125B	Plunger H.S.G.
34	341X.116	Slotted Washer.	74	14.07.04	4mm Tubing Nut	114	358X.126	Fulcrum Pin.
35	154/04	3/8" Spring Washer (2"-6 only).	75	14.08.04	4mm Tubing Sleeve	115	358Z.158	Thrust Ring (2"-6 only).
36	155/0416	1/2" B.S.F. Socket Head Cap Screw, 1" long (2"-6 only).	76	358X.161	Spring.	116	154/10	3/8" Spring Washer.
37	358Z.101	Bar Feed Slide.	77	358X.152	Spring Guide.	117	155/1024	1/2" B.S.F. Socket Head Cap Screw, 1 1/2" long.
38	358X.157	Guide Bar.	78	155/1032	1/2" B.S.F. Socket Head Cap Screw, 2" long.	118	172X.107A	Instruction Plate.
39	358Z.150A	Driving Disc.	79	154/10	3/8" Spring Washer.	119	165/206	2 B.A. Round Head Screw, 3/8" long.
40	358X.115	Roller.	80	14.75.0402	4mm Male Elbow			

List of Parts for
PLATE No. 49
(Drawing No. 358 Z I)

WHEN ORDERING SPARE PARTS ALWAYS QUOTE THE SERIAL NUMBER OF THE MACHINE

HYDRAULIC CONTROL – FRONT VIEW

6 1/2" - 6H CHUCKING MACHINES

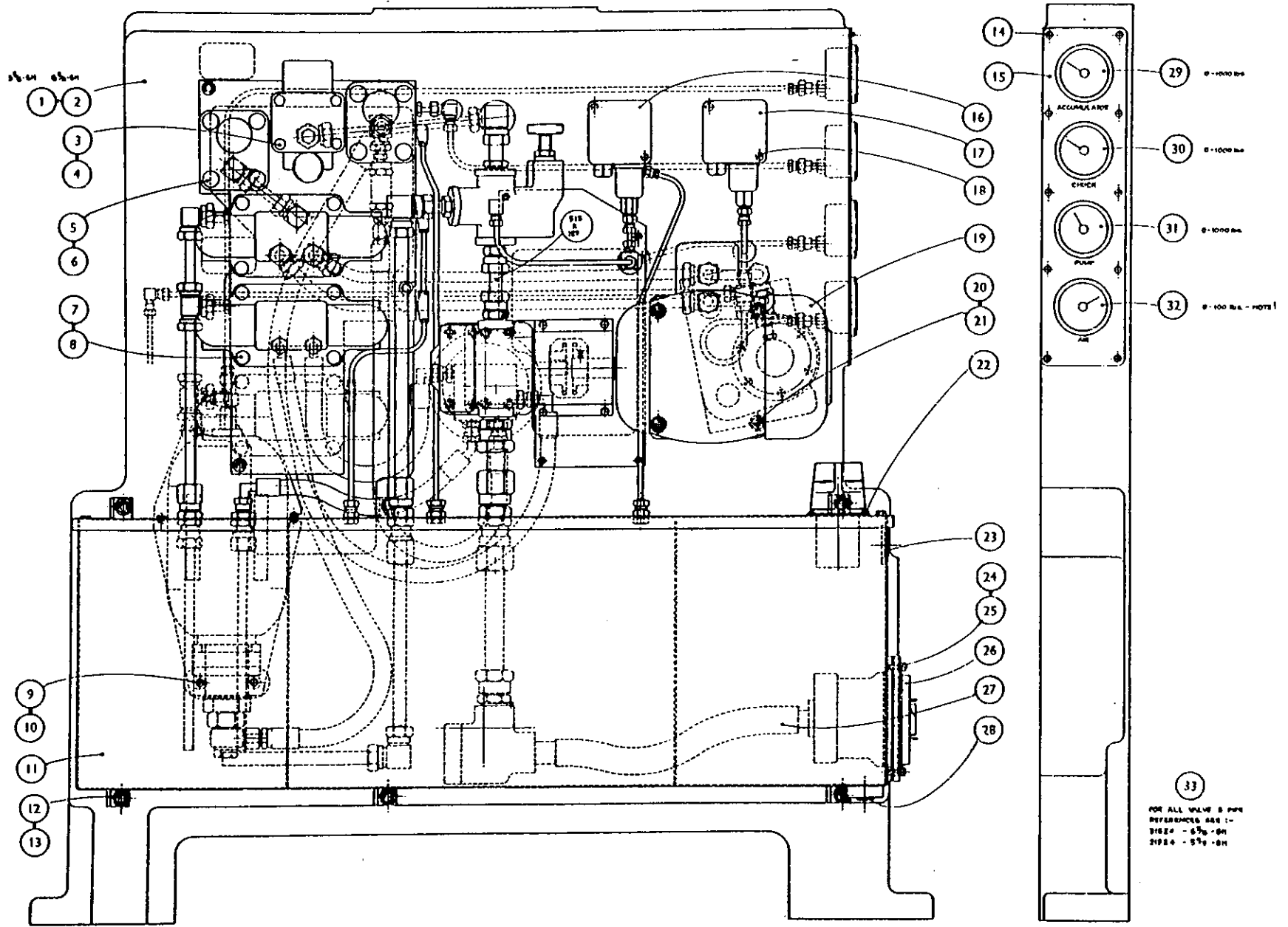

33
 FOR ALL VALVE & PIPE
 REFERENCES SEE --
 21824 - 6 1/2" - 6H
 21824 - 5 1/2" - 6H

315 Z 1A HYDRAULIC CONTROL ARRANGEMENT FRONT VIEW

6 $\frac{1}{2}$ "- 6, 5 $\frac{1}{4}$ "- 6, 7 $\frac{1}{4}$ "- 6, 6"- 8 MACHINES. SECTIONS 215, 315, 515

First Used On
Machine 15784

INDEX NO.	PART NO.	TITLE	INDEX NO.	PART NO.	TITLE
1	215Z.110B	End Bracket (6 $\frac{1}{2}$ "- 6)	23	154/03	Spring Washer, for 3/16" dia.
2	315Z.110B	End Bracket (6 $\frac{1}{2}$ "- 6)	24	198/14	Shakeproof Lockwasher, for 7/16" dia.
3	515Z.110C	End Bracket (6"- 8, 7 $\frac{1}{4}$ "- 6)	25	169/0720	High Tensile Hexagon Head Set Screw, 7/16" B.S.F. x 1 $\frac{1}{4}$ " long
4	154/05	Spring Washer, for 5/16" dia.	26	D 100 La	Motor, Foot-Mounted, 3h.p., 1500 r.p.m.
5	155/0544	Socket Head Cap Screw, 5/16" B.S.F. x 2 $\frac{1}{4}$ " long	27	160/206	Socket Dome Head Screw, 2 B.A. x $\frac{3}{4}$ " long
6	154/04	Spring Washer, for $\frac{1}{4}$ " dia.	28	160/208	Socket Dome Head Screw, 2 B.A. x $\frac{1}{2}$ " long
7	155/0424	Socket Head Cap Screw, $\frac{1}{4}$ " B.S.F. x 1 $\frac{1}{2}$ " long	29	515Y.107A	Pressure Gauge Plate (6"- 8)
8	198/8	Shakeproof Lock Washer, for $\frac{1}{4}$ " dia.	30	515X.174	Legend Plate
9	167/0408	Hexagon Head Set Screw, $\frac{1}{4}$ " B.S.F. x $\frac{1}{2}$ " long	31	160/208	Socket Dome Head Screw, 2 B.A. x $\frac{1}{2}$ " long
10	515X.176	Needle Valve Bracket	32	GP-140NFLS	Smiths Pressure Gauges, 3"
11	515Z.101C	Hydraulic Tank	33	315X.505	Blanking Boss
12	169/0714	High Tensile Hexagon Head Set Screw, 7/16" B.S.F. x $\frac{7}{8}$ " long	34	315X.506	Strap
13	198/14	Shakeproof Lock Washer, for 7/16" dia.	35	215X.178	Chuckling Pressure Instruction Plate (5 $\frac{1}{2}$ "- 6)
14	315V.168A	Cover	36	315X.178	Chuckling Pressure Instruction Plate (6 $\frac{1}{2}$ "- 6)
15	155/0408	Socket Head Cap Screw, $\frac{1}{4}$ " B.S.F. x $\frac{1}{2}$ " long	37	515X.178	Chuckling Pressure Instruction Plate (7 $\frac{1}{4}$ "- 6)
16	515X.130A	Renold Chain Coupling	38	515X.180	Chuckling Pressure Instruction Plate (8"- 8)
17	155/0428	Socket Head Cap Screw, $\frac{1}{4}$ " B.S.F. x 1 $\frac{1}{4}$ " long	39	165/404	Round Head Set Screw, 4 B.A. x $\frac{1}{2}$ " long
18	154/04	Spring Washer, for $\frac{1}{4}$ " dia.	40	10T.25.M.3CT.ST.MAG.	Rosari Tell-Tale Submersible Filter
19	154/04	Spring Washer, for $\frac{1}{4}$ " dia.	41	154/05	Spring Washer, for 5/16" dia.
20	155/0424	Socket Head Cap Screw, $\frac{1}{4}$ " B.S.F. x 1 $\frac{1}{2}$ " long	42	155/0514	Socket Head Cap Screw, 5/16" B.S.F. x $\frac{7}{8}$ " long
21	515X.173	Isolator Block	43	-	Magnetic Plug, $\frac{1}{4}$ " B.S.P.
22	156/220	Socket Head Cap Screw, 2 B.A. x 1 $\frac{1}{4}$ " long	44	-	See 315 Z 4A for references of hydraulic equipment

List of Parts for
Plate No. 2A
(Drawing No. 315 Z 1A)

WHEN ORDERING SPARE PARTS ALWAYS QUOTE THE INSPECTION NUMBER OF THE MACHINE

HYDRAULIC CONTROL ARRANGEMENT, FRONT VIEW

6 1/2"-6 CHUCKING MACHINES

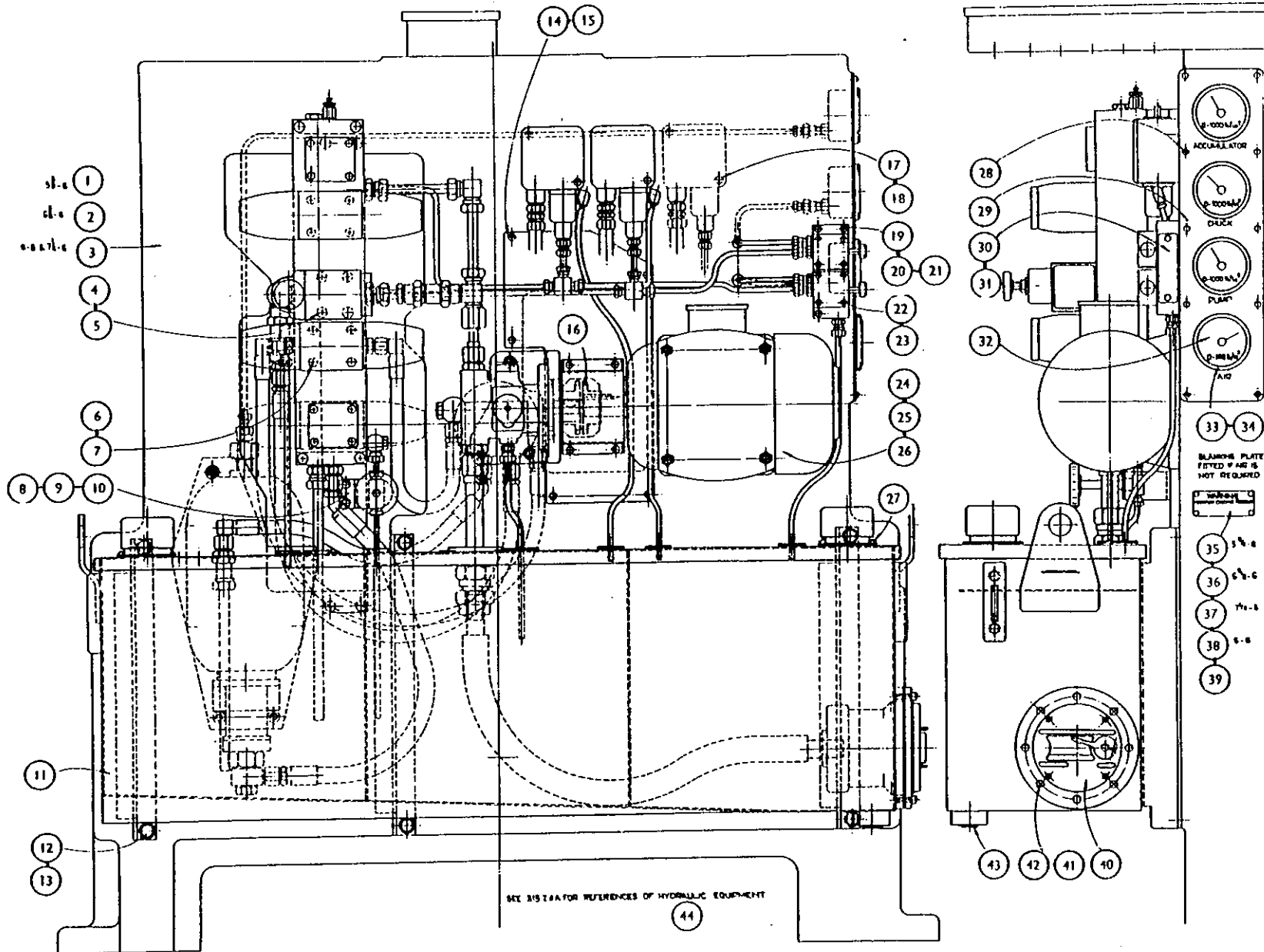

PLATE No.2A
(Drawing No.315Z1A)

315 Z 2 HYDRAULIC CONTROL ARRANGEMENT (PLAN)

6 $\frac{1}{4}$ " - 6H MACHINES. SECTION 315

Last used on
Inspection No.15783

INDEX NO.	PART NO.	TITLE
1	661002	Renold Anchor Stud
2	110046	Renold Chain
3	661101	Renold Link
4	173/06L	$\frac{3}{8}$ " BSF Hexagon Locknut
5	615X.168	Chain Adjuster
6	515Y.167	Adaptor Plate for accumulator
7	154/06	$\frac{3}{8}$ " Spring Washer
8	155/0616	$\frac{3}{8}$ " BSF Socket Head Cap Screw 1" long
9	154/07	$\frac{7}{16}$ " Spring Washer
10	155/0724	$\frac{7}{16}$ " BSF Socket Head Cap Screw 1 $\frac{1}{2}$ " long
11	615X.127A	Pump Packer
12	515X.130	Renold Chain Coupling
13	176/0405	$\frac{1}{4}$ " BSF Socket Set Screw 5/16" long cup point
14	515V.132	Drive Shaft Cover
15	155/0408	$\frac{1}{4}$ " BSF Socket Head Cap Screw $\frac{1}{2}$ " long
16	515X.137	Oil Instruction Plate
17	165/404	4BA Round Head Screw $\frac{1}{4}$ " long

List of Parts for
Plate No.3
(Drawing No.315Z2)

WHEN ORDERING SPARE PARTS ALWAYS QUOTE THE INSPECTION NUMBER OF THE MACHINE

HYDRAULIC CONTROL PLAN
6 1/2" - 6H CHUCKING MACHINES

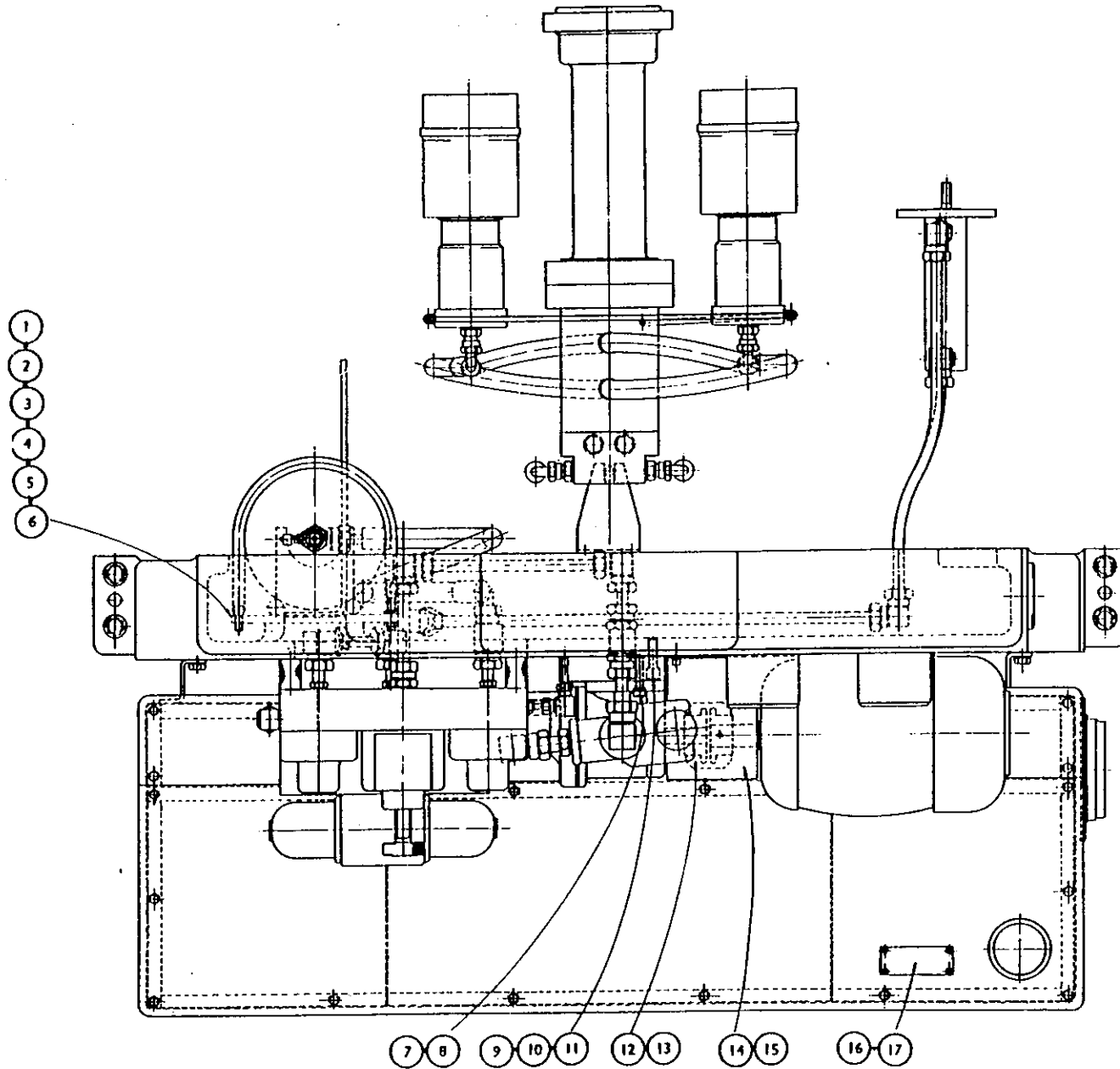

315 Z 2A HYDRAULIC CONTROL ARRANGEMENT (PLAN)

6 3/4" - 6 MACHINE. SECTION 315

First Used On
Machine 15784

INDEX NO.	PART NO.	TITLE
1	66 1002	Renold Anchor Stud
2	10046	Renold Chain
3	66 1101	Renold Link
4	173/06L	Locknut, 3/8" B.S.F.
5	515X.168	Chain Adjuster
6	515Y.167	Adaptor Plate
7	154/08	Spring Washer, for 1/2" dia.
8	155/0832	Socket Head Cap Screw, 1/4" B.S.F. x 2" long
9	515Y.171	Manifold Mounting Bridge
10	154/06	Spring Washer, for 3/8" dia.
11	155/06 20	Socket Head Cap Screw, 3/8" B.S.F. x 1 1/4" long
12	515Z.102B	Hydraulic Valve Manifold
13	154/06	Spring Washer, for 3/8" dia.
14	155/0662	Socket Head Cap Screw, 3/8" B.S.F. x 3/4" long
15	155/404	Round Head Set Screw, 4 B.A. x 1/4" long
16	315X.174	Pressure Relieving Instruction Plate
17	154/07	Spring Washer, for 7/16" dia.
18	155/0724	Socket Head Cap Screw, 7/16" B.S.F. x 1 1/4" long
19	515X.127C	Pump Bracket Packer
20	PVO-PSEJ-D6-EL-01	Racine Pump
21	159/0620	High Tensile Hexagon Head Set Screw, 3/8" B.S.F. x 1 1/4" long
22	515Y.172A	Pump Bracket
23	155/0408	Socket Head Cap Screw, 1/4" B.S.F. x 1/2" long
24	515V.132A	Drive Shaft Cover
25	155/404	Round Head Set Screw, 4 B.A. x 1/4" long
26	515X.137	Oil Instruction Plate

List of Parts for
Plate No. 3A
(Drawing No. 315 Z2A)

WHEN ORDERING SPARE PARTS ALWAYS QUOTE THE INSPECTION NUMBER OF THE MACHINE

6 1/2" - 6 CHUCKING MACHINE

Machine No.15784

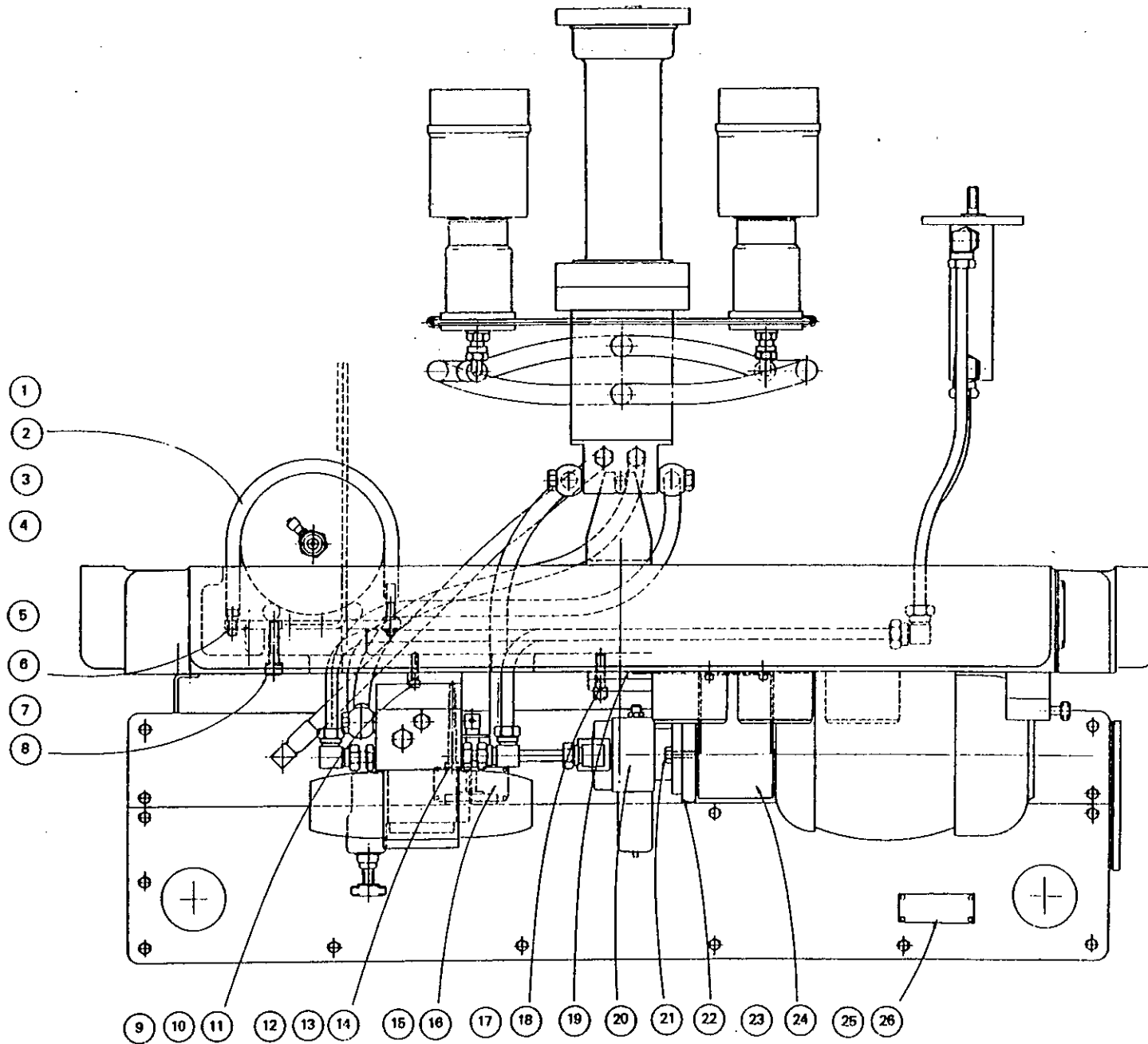

315 Z 3 HYDRAULIC CONTROL ARRANGEMENT (END)

6½"-6H MACHINES. SECTION 315

Last used on
Inspection No.15783

INDEX NO.	PART NO.	TITLE
1	165/404	4BA Round Head Screw ¼" long
2	515X.140A	Warning Plate
3	615X.131	Spacer
4	515Z.102A	Hydraulic Manifold
5	165/0864	½" BSF Socket Head Cap Screw 4" long
6	154/08	½" Spring Washer
7	155/0412	½" BSF Socket Head Cap Screw ¾" long
8	315V.168	Cover
9	154/08	½" Spring Washer
10	155/0820	½" BSF Socket Head Cap Screw 1¼" long
11	354/0514	'O' Ring
12	516X.141	Blanking Plate
13	-	Only Required on Single Index Machines

List of Parts for
Plate No. 4
(Drawing No.315Z3)

WHEN ORDERING SPARE PARTS ALWAYS QUOTE THE INSPECTION NUMBER OF THE MACHINE

HYDRAULIC CONTROL - END

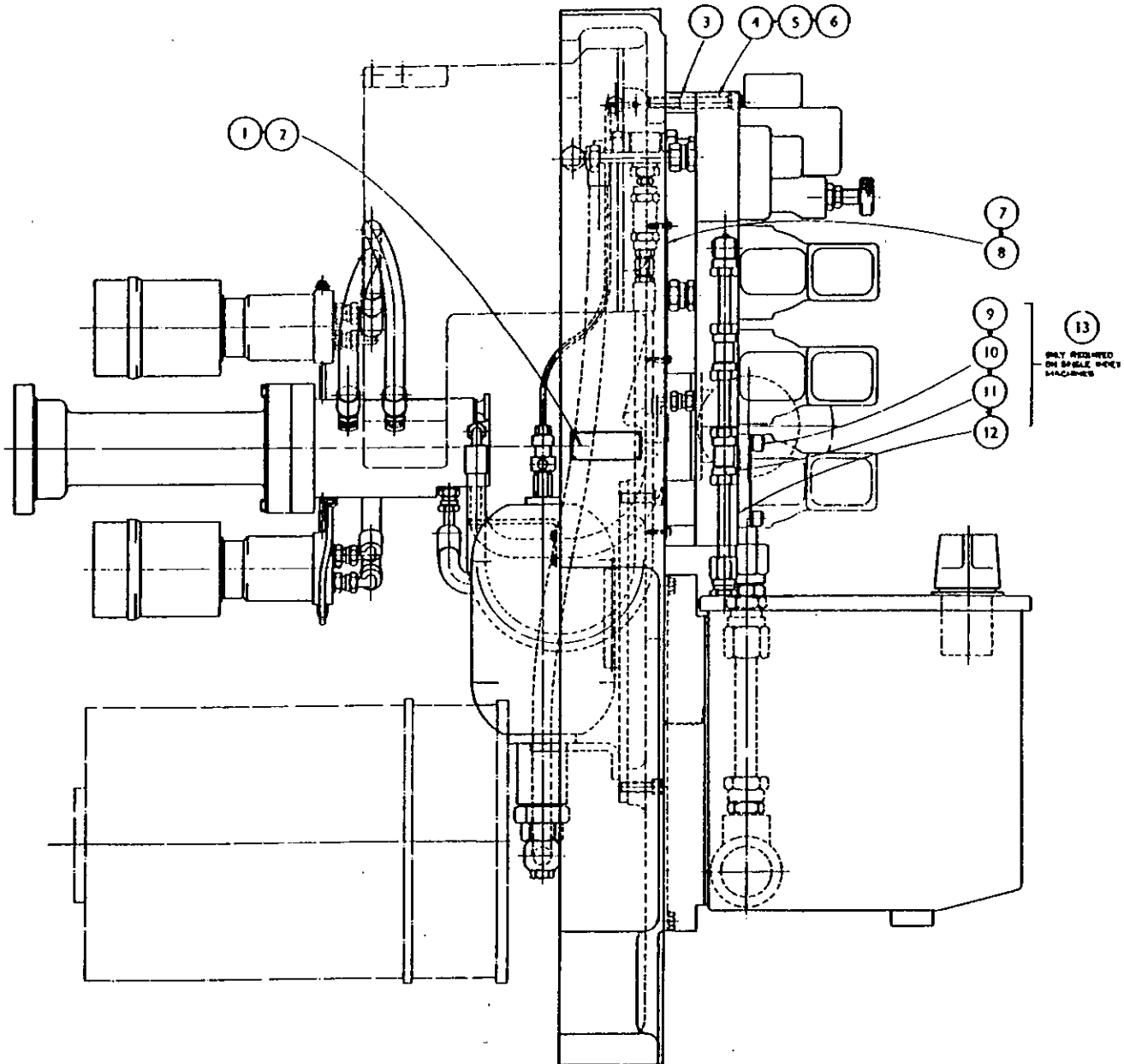

13
ONLY REQUIRED
ON SPALL-WORK
MACHINES

315 Z 3A HYDRAULIC CONTROL ARRANGEMENT, REAR VIEW
6 $\frac{3}{4}$ "-6 MACHINE. SECTION 315

**First Used On
Machine 15784**

INDEX NO.	PART NO.	TITLE
1	515X.140A	Instruction Plate
2	165/404	Round Head Screw, 4 B.A. x $\frac{1}{4}$ " long

List of Parts for
Plate No. 4A
(Drawing No. 315 Z3A)

WHEN ORDERING SPARE PARTS ALWAYS QUOTE THE INSPECTION NUMBER OF THE MACHINE

6 1/4" - 6 CHUCKING MACHINE

Machine No.15784

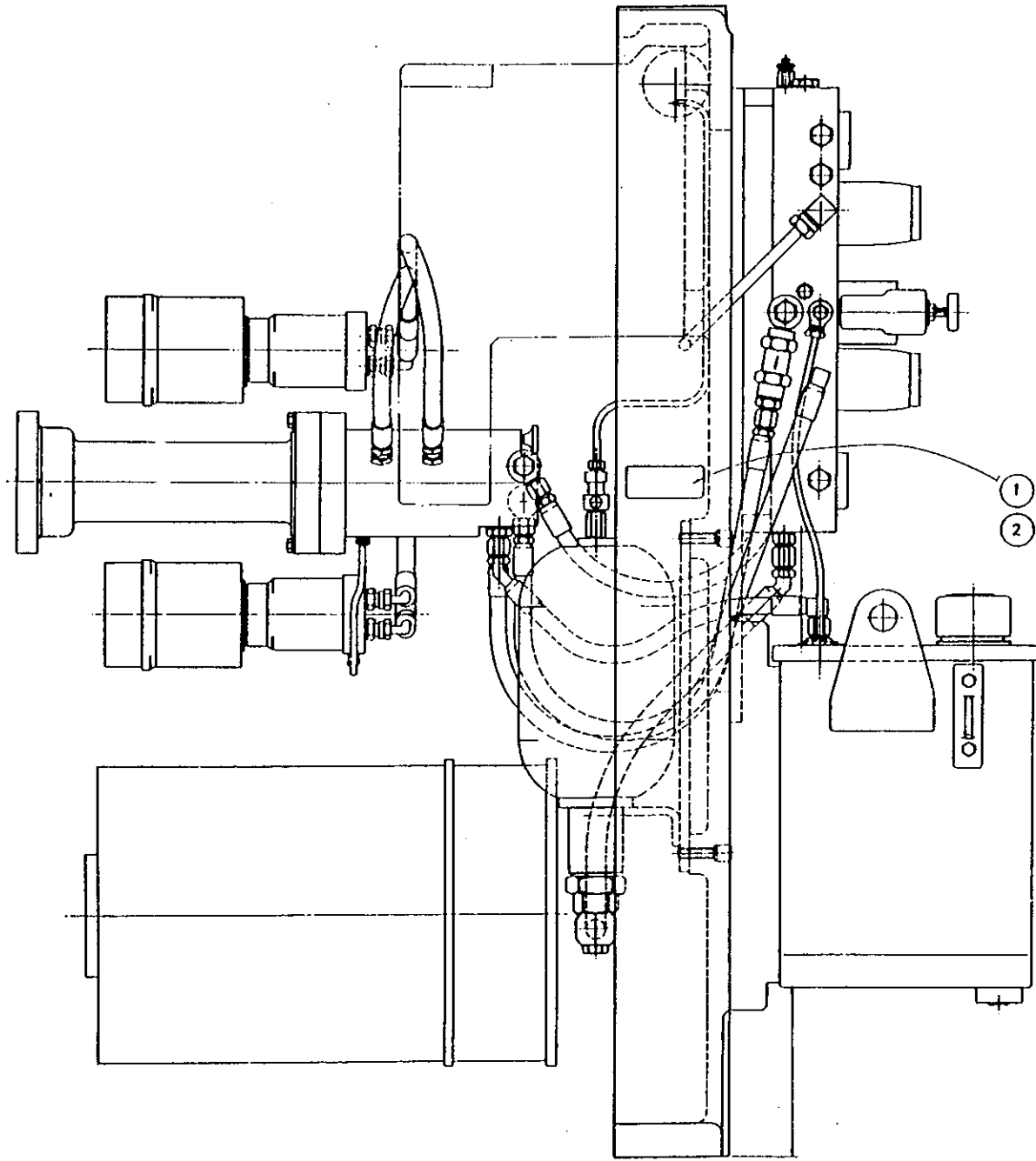

315 Z 4 HYDRAULIC CONTROL PIPING DIAGRAM (SINGLE INDEX)

6 1/2" - 6H CHUCKING MACHINES

Last used on
Inspection No.15783

INDEX NO.	PART NO.	TITLE
2	316X.144	Flexible Hose Assembly
3	316X.143	Flexible Hose Assembly
4	XCG-06-F	Vickers Pressure Reducing and Check Valve
5	NR 0303T	Keelavite in line Non Return Valve
6	316X.146 }	Flexible Hose Assembly
7	316X.148 }	
8	316X.147 }	
9	316X.149 }	
10	-	Spindle Stopping Cylinder
11	ACW 1	Industrial Pressure Switch. Square D
12	ADW 3	Industrial Pressure Switch. Square D
13	CT-06-B-10	Vickers 3/4" Relief Valve. Hydrocone Type
14	NR 8R	Keelavite in line Non Return Valve
16-16	C2G-815	Vickers 3/4" Check Valve C2G-815
17	516X.145	Flexible Pipe Assembly
18	-	Greer Mercier charging Valve
19-20	DG6S4-082C-50	Vickers 3/4" Four Way Valve
21	516X.129	Stem
22	-	To Air Supply
23	V-104-A-10	Vickers Vane Pump. Small Series
24	GP-140 NFLS	Smiths Pressure Gauge 3"
25	ZFB-1550-EW	Vickers Air Filter & Oil Filter
26	10-T	Rosean Submersible Filter
27	516X.141	Blanking Plate
	354/0514	Seal
	155/0820	1/2" BSF Socket Head Cap Screw 1 1/4" long
	154/08	1/2" Spring Washer
28	-	Notel - only fit Drain Pipes where Valves are fitted
29	C 15	Greer Mercier 1 gallon Hydraulic Accumulator
30	--	Steel Pipes - Scale less cold drawn seamless Tube
		Copper Pipes - WSP 226/4060
		Griflex Pipes - Surlan Nylon Tube 1/2" Dia.
		Semi Rigid 1/2" & 3/4" Dia.
		Flexible Pipes - Industrial Hydraulics Flexible Single Wire Hose
		Steel Pipe Sizes Griflex Pipe Sizes Copper Pipe Size
		For Air Equipment only
31	964	Keelavite Non Return Valve without spring
32	-	Rosean Flexible Connection

List of Parts for
Plate No.5
(Drawing No.31524)

WHEN ORDERING SPARE PARTS ALWAYS QUOTE THE INSPECTION NUMBER OF THE MACHINE

HYDRAULIC CONTROL PIPING DIAGRAM (SINGLE INDEX)

6 1/2" - 6H CHUCKING MACHINE

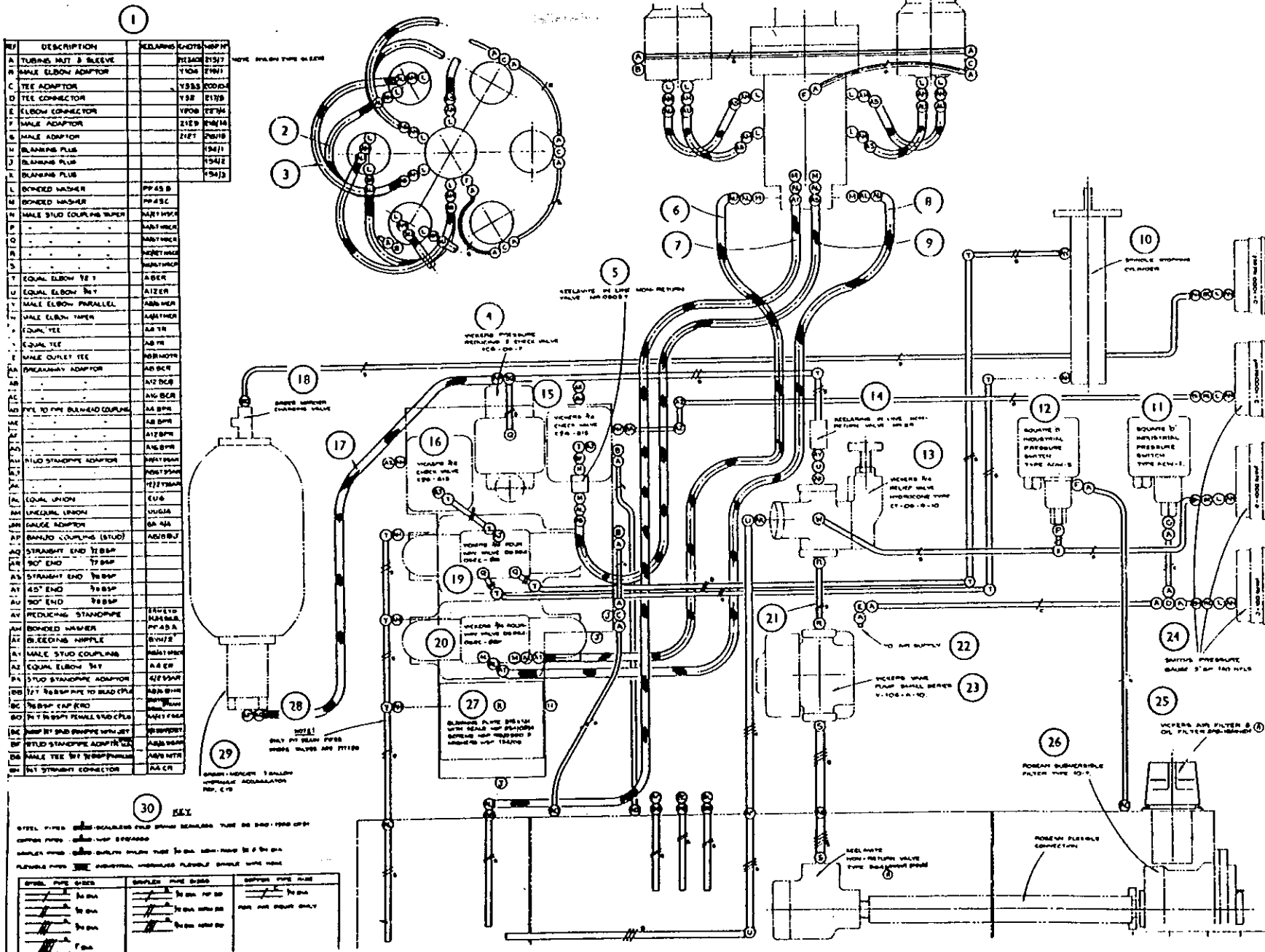

315 Z 4A HYDRAULIC CONTROL PIPING DIAGRAM

6 1/2" - 6 MACHINE. SECTION 315

First Used On
Machine 15784

1

REF.	KEELARING	ENOTS	W.S.P. No.	REF.	KEELARING	ENOTS	W.S.P. No.
A	TUBING NUT & SLEEVE	Z17,Z403	215/7	AC	STUD BANJO COUPLING 1/2 B.S.P.	A8/6BJ	
B	MALE ELBOW ADAPTOR	Y104	219/1	AD	STUD BANJO COUPLING 1/2 B.S.P.	A8/8BJ	
C	TEE ADAPTOR	Y333	200/04	AE	UNEQUAL UNION 1/2-1/4 B.S.P.	UU8/8	
D	TEE CONNECTOR	Y32	217/5	AF	UNEQUAL UNION 1/2-1/4 B.S.P.	UU6/4	
E	ELBOW CONNECTOR	Y208	227/4	AG	EQUAL UNION 1/2 B.S.P.	EU8	
F	MALE ADAPTOR	Z129	218/14	AH	BULKHEAD CONNECTOR 1/2T.-1/2 B.S.P.	A8/6BHR	
G	BLANKING PLUG			AJ	FEMALE STUD COUPLING 1" T-1" B.S.P.	A16/16FSCR	
H				AK	ELBOW 1/2T	A8ER	
J				AL	MALE ELBOW 1/2T.-1/2 B.S.P.	A8/6MER	
K				AM	BREAKAWAY ADAPTOR	A8BCR	
L	BONDED WASHER 1/4 B.S.P.	PP45A		AN	STUD STANDPIPE ADAPTOR 1/2T.-1/4 B.S.P.	8/6SSAR	
M	BONDED WASHER 1/4 B.S.P.	PP45B		AP	STUD STANDPIPE ADAPTOR 1/2T.-1/4 BSPT	8/4T.SSAR	
N	BONDED WASHER 1/2 B.S.P.	PP45C		AQ	STUD STANDPIPE WITH JET 1/2T.-1/4 BSP	4/4SSAR/JET.	
P	MALE STUD COUPLING 1/2T.-1/2 B.S.P.	A8/6MSCR		AR	ADAPTOR BUSH 1/4 NPTF 1/4 B.S.P.	AB4AT/4	
Q	MALE STUD COUPLING 1/2T.-1/2 B.S.P.	A4/2MSCR		AS	STRAIGHT END FITTING		
R	MALE STUD COUPLING 1/2T.-1/4 B.S.P.	A4/4MSCR		AT	45° END FITTING		
S	MALE STUD COUPLING 1/2T.-1/4 B.S.P.T.	A8/4T.MSCR		AU	90° END FITTING		
T				AV	EQUAL TEE 1/2T.	A8 TR	
U	MALE OUTLET TEE 1/2T.-1/2 B.S.P.	A8/6MOTH		AW	EQUAL TEE 1/2T.	A4 TR	
V	ADAPTOR BUSH 1/4 NP.T.F.-1/4 B.S.P.	AB AT/4		AX	1/2 B.S.P. CAP	BRITISH STEAM 494S	
W	STRAIGHT COUPLING 1/2T.	A4CR		AY	STRAIGHT THREAD CONNECTOR 1/2T - 1/2 UNF.	PARKER HANIFIN 8-10 F5 BX-S	
X	GAUGE ADAPTOR 1/2T.-1/4 B.S.P.	GA4/4		AZ	STRAIGHT THREAD CONNECTOR 1" T-1.1/16 UNF.	PARKER HANIFIN 16-12 F5 BX-S	
Y	FEMALE STUD COUPLING 1/2T.-1/4 B.S.P.	A4/4 FSCR		BA	BLANKING BODY	8 BPGR	
Z	BLANKING PLUGS 1/2 B.S.P.	P6		BB	1/2 B.S.P. PLUG	W.S.P.194/1	
AA	BLEED NIPPLE 1/2 B.S.P.	BVH/2		BC	MALE STUD COUPLING	A4/6T MSCR	
AB	BANJO COUPLING 1/2T. 1/2 B.S.P.	A4/2BJR		BD	MALE STUD COUPLING	A4/4T MSCR	
				BE			
				BF			
				BG			

List of Parts for
Plate No. 5A
(Drawing No. 315 Z4A)

WHEN ORDERING SPARE PARTS ALWAYS QUOTE THE INSPECTION NUMBER OF THE MACHINE

HYDRAULIC CONTROL PIPING DIAGRAM

6 1/2" - 6H CHUCKING MACHINE

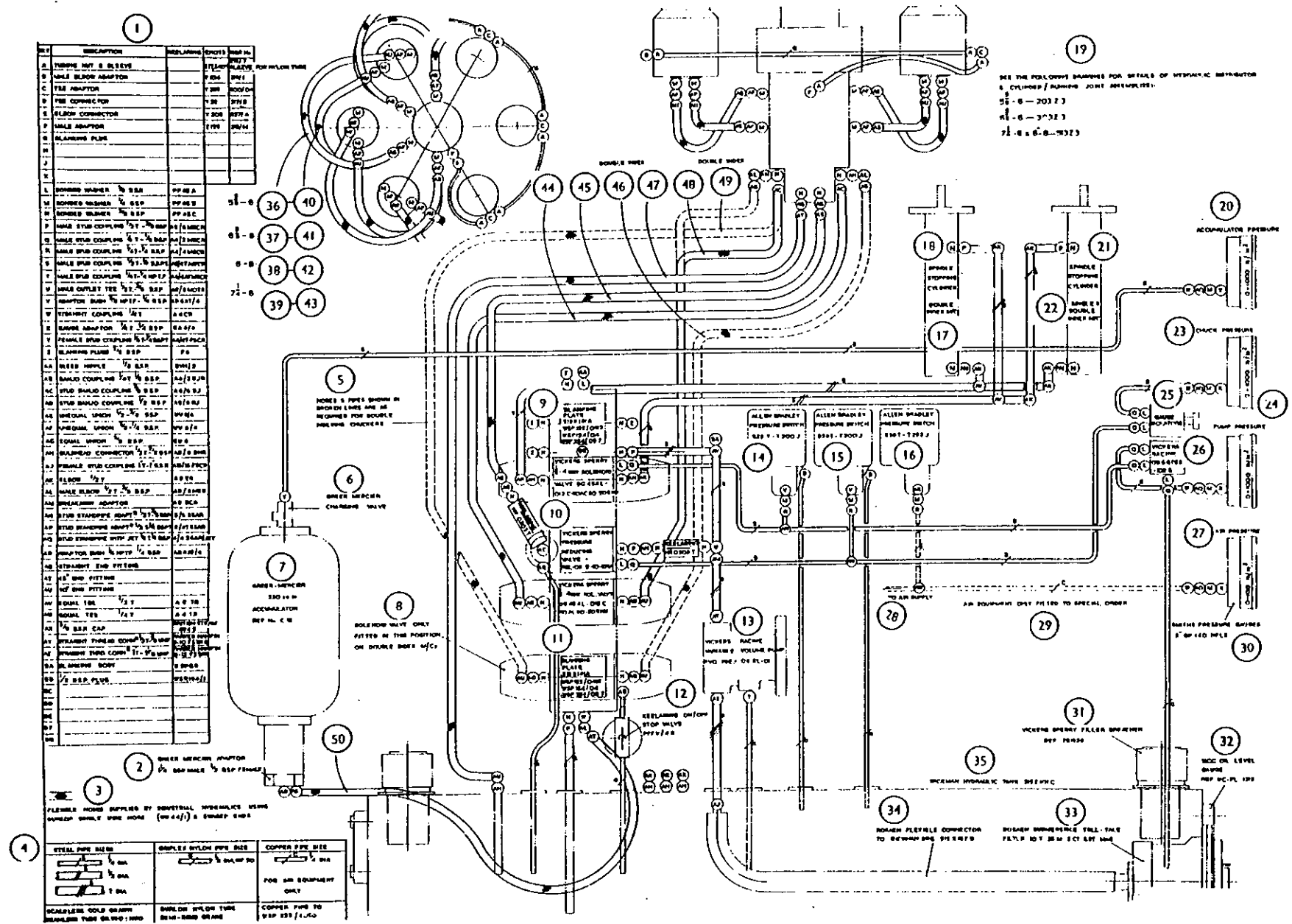

NO.	DESCRIPTION	QUANTITY	NOTE	REF. NO.
1	TRUCK HOSE & BELLEVILLE	1/2" DIA	FOR HYDRAULIC	
2	MALE BREAK ADAPTOR	1/2" DIA		
3	THE ADAPTOR	1/2" DIA		
4	THE CONNECTOR	1/2" DIA		
5	ELBOW CONNECTOR	1/2" DIA		
6	MALE ADAPTOR	1/2" DIA		
7	BLANKING PLUG	1/2" DIA		

8	300 PSI ACCUMULATOR	1		
9	1/2" DIA. BREAKER MOTOR	1		
10	1/2" DIA. BREAKER MOTOR	1		
11	1/2" DIA. BREAKER MOTOR	1		
12	1/2" DIA. BREAKER MOTOR	1		
13	1/2" DIA. BREAKER MOTOR	1		
14	1/2" DIA. BREAKER MOTOR	1		
15	1/2" DIA. BREAKER MOTOR	1		
16	1/2" DIA. BREAKER MOTOR	1		
17	1/2" DIA. BREAKER MOTOR	1		
18	1/2" DIA. BREAKER MOTOR	1		
19	1/2" DIA. BREAKER MOTOR	1		
20	1/2" DIA. BREAKER MOTOR	1		
21	1/2" DIA. BREAKER MOTOR	1		
22	1/2" DIA. BREAKER MOTOR	1		
23	1/2" DIA. BREAKER MOTOR	1		
24	1/2" DIA. BREAKER MOTOR	1		
25	1/2" DIA. BREAKER MOTOR	1		
26	1/2" DIA. BREAKER MOTOR	1		
27	1/2" DIA. BREAKER MOTOR	1		
28	1/2" DIA. BREAKER MOTOR	1		
29	1/2" DIA. BREAKER MOTOR	1		
30	1/2" DIA. BREAKER MOTOR	1		
31	1/2" DIA. BREAKER MOTOR	1		
32	1/2" DIA. BREAKER MOTOR	1		
33	1/2" DIA. BREAKER MOTOR	1		
34	1/2" DIA. BREAKER MOTOR	1		
35	1/2" DIA. BREAKER MOTOR	1		

STEEL PIPE SIZE	BRASS PIPE SIZE	COPPER PIPE SIZE
1/2" DIA	1/2" DIA	1/2" DIA
3/8" DIA	3/8" DIA	3/8" DIA
1/4" DIA	1/4" DIA	1/4" DIA

SCALELESS COIL DRAWN
SCALELESS TUBE GA. 100/1000

BRASS PIPE ON TUBE
SCALE - 100/1000

COPPER PIPE TO
SIP 253/1000

SEE THE FOLLOWING DRAWINGS FOR DETAILS OF HYDRAULIC INSTRUMENTS & CYLINDERS / VALVES / JOINTS / ACCESSORIES:
 55 - 6 - 203 7 3
 56 - 6 - 3 3 2 3
 71 - 6 - 6 - 103 3

315 Z 5 AUXILIARY CAMSHAFT DRIVE ARRANGEMENT
AIR CHUCKER 6 $\frac{1}{4}$ "-6, HYDRAULIC CHUCKER 6 $\frac{1}{4}$ "-6H. SECTIONS 314, 315

INDEX NO.	PART NO.	TITLE
1	155/0824	Socket Head Cap Screw, $\frac{1}{2}$ " B.S.F. x $1\frac{1}{2}$ " long (Section 344H)
2	154/08	Spring Washer, for $\frac{1}{2}$ " dia. (Section 344H)
3	263/60	Ball Journal, Angular Contact, Light Type, Metric - 60 - 110 - 22mm (Section 344H)
4	344X.145B	Thrust Ring (Section 344H)
5	210/2525	Indicator Washer
6	212/4518	Nipple, $\frac{1}{4}$ " B.S.P.
7	-	For all other main camshaft information see 344Z1
8	544X.152	Coupling Pin (Section 344H)
9	155/0624	Socket Head Cap Screw, $\frac{3}{8}$ " B.S.F. x $1\frac{1}{2}$ " long (Section 344H)
10	155/0824	Socket Head Cap Screw, $\frac{1}{2}$ " B.S.F. x $1\frac{1}{2}$ " long (Section 344H)
11	154/08	Spring Washer, for $\frac{1}{2}$ " dia. (Section 344H)
12	203/10L	Selflocking Nut, $\frac{3}{8}$ " B.S.F.
13	130/10	Washer, for $\frac{5}{8}$ " dia.
14	-	For further auxiliary camshaft information see 315 Z6
15	544Y.121C	End Bearing Housing (Section 344H)
16	515V.150A	End Cover (Section 344H)
17	1615	Fenner Taper Bush, $9/16$ " bore
18	122/0620T	Key, Tapped, $3/16$ " x $5/32$ " x $1\frac{1}{2}$ " long
19	515X.154	Retaining Pin (Section 344H)
20	30 H 100	Fenner Timing Pulley
21	450 H 100	Fenner Timing Belt
22	515X.162	Jockey Roller
23	130/12	Flat Washer, for $3/4$ " dia.
24	515X.151	Jockey Shaft
25	355/75	External Circlip, $3/4$ "
26	215X.175	Belt Tension Plate
27	30 H 100	Fenner Timing Pulley
28	1615	Fenner Taper Bush, 1" bore
29	122/0824T	Key, Tapped, $1/2$ " x $3/16$ " x $1\frac{1}{2}$ " long
30	315Y.116	Auxiliary Camshaft
31	355/118	External Circlip, 30 mm
32	280/30	Ball Journal, Light Type, with Double Seals, 30 x 62 x 16 mm
33	356/243	Internal Circlip, 62 mm
34	515X.153	Bearing Housing
35	182/0824	Socket Set Screw, Taper Point, $1/2$ " B.S.F. x $1\frac{1}{2}$ " long
36	203/08	Selflocking Nut, $1/2$ " B.S.F.

WHEN ORDERING SPARE PARTS ALWAYS QUOTE THE INSPECTION NUMBER OF THE MACHINE

List of Parts for
 Plate No. 6
 (Drawing No. 315 Z5)

6 3/4" - 6, 6 3/4" - 6H CHUCKING MACHINES

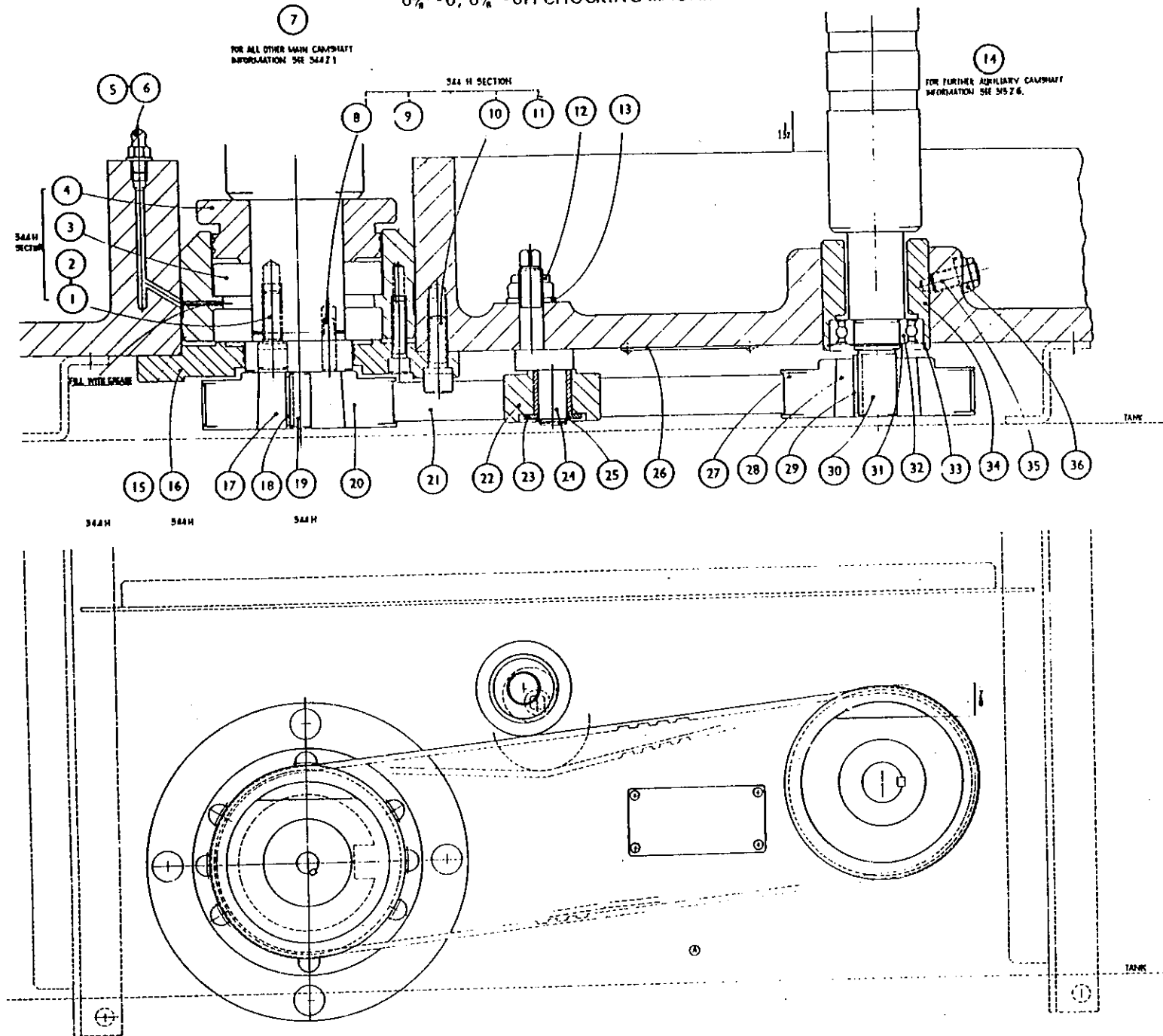

PLATE No. 6
(Drawing No. 31525)

315 Z 6 CAM TIMING ARRANGEMENT

6 $\frac{1}{4}$ "-6, 6 $\frac{1}{2}$ "-6H MACHINE. SECTIONS 314, 315

INDEX NO.	PART NO.	TITLE
1	—	For Conduit Arrangement see 371 Z 19
2	—	For Guard Arrangement see 322 Z 6
3	9219X.116B	Tube
4	165/0512	Socket Head Cap Screw, 5/16" B.S.F. x $\frac{1}{4}$ " long
5	816Y.111	Limit Switch Plate
6	316Z.120	Cam Timing Compartment
7	122X.130	Door Knob
8	316V.109	Camshaft Cover
9	166/228	Socket Head Cap Screw, 2 B.A. x 1 $\frac{1}{2}$ " long
10	164/03	Spring Washer, for 3/16" dia.
11	AW.36	Limit Switch, Square D
12	165/0420	Socket Head Cap Screw, $\frac{1}{4}$ " B.S.F. x 1 $\frac{1}{4}$ " long
13	164/04	Spring Washer
14	615X.117	Switch Cam (Short)
15	616X.118	Switch Cam (Long)
16	169/0508	High Tensile Hexagon Head Set Screw, 5/16" B.S.F. x $\frac{1}{4}$ " long
17	315X.176	Legend Plate Strip (View with cover removed)
18	291/-	Klippon Standard Terminal
19	—	For arrangement of Camshaft Drive see 316Z5
20	169/210	Socket Countersunk Screw, 2 B.A. x $\frac{5}{8}$ " long
21	174/2	Locknut, 2 B.A.
22	164/06	Spring Washer, for $\frac{3}{8}$ " dia.
23	165/0624	Socket Head Cap Screw, $\frac{3}{8}$ " B.S.F. x 1 $\frac{1}{2}$ " long
24	210/2625	Indicator Washer
25	212/18	Oil Nipple, $\frac{1}{4}$ " B.S.P.
26	316X.114	Camshaft End Bearing
27	139/11	Taper Pin

WHEN ORDERING SPARE PARTS ALWAYS QUOTE THE INSPECTION NUMBER OF THE MACHINE

List of Parts for
Plate No.7
(Drawing No. 315 Z 6)

Handwritten text, possibly bleed-through from the reverse side of the page, located along the right edge.

ATTACHMENTS

**WICKMAN
MULTI-SPINDLE
AUTOMATICS**

THREADING CLUTCH DRIVE, SECTION 381 MK.I

2¼"-6, 2¼"-6D, 2"-6, 2"-6D BAR MACHINES. 6½"-6, 6½"-6D CHUCKING MACHINES

INDEX NO.	PART NO.	TITLE	INDEX NO.	PART NO.	TITLE
1	176/0406	½" B.S.F. Hexagon Socket Set Screw Cup Point ¾" long	31	381X.105	Thrust Washer
2	124/1028	Parallel Pin, 5/16" dia. 1¼" long	32	381V.106A	Clutch Sleeve
3	146/319	Extension Spring ¾" dia. 3" long	33	318V.198	No.5 Herbert Double Type Multi-grip Clutch
4	508X.209	Spring Anchor (Short)	34	124/1016	Parallel Pin 5/16" dia. 1" long
5	381X.125	Spring Anchor Bush	35	381V.101	Clutch Shaft
6	127/0405	Split Cotter Pin 1/16" dia. ¾" long	36	381X.108A	Clutch Key
7	597BX.124	Fork Pin	37	164/05	Lockwasher
8	597BX.123	Trip Rod Fork	38	165/0520	5/16" B.S.F. Hexagon Socket Cap Screw 1¼" long
9	381X.121	Latch	39	381X.107	End Spacer
10	381X.122	Spring Anchor	40	163/42	Soft Pad
11	381X.120	Detent Sleeve	41	179/204	2 B.A. Hexagon Socket Set Screw Cup Point ¼" long
12	236/161816	Oil Retaining Bush	42	161/25	Slotted Locknut
13	381X.117	Buffer Sleeve	43	225/3050	Copper Tube 3/16" dia. 189. 30" long
14	381V.119A	Glut Shaft	44	668X.162	Oil Nipple
15	381X.116	Locknut	45	381X.110	End Bearing Housing
16	165/0620	½" B.S.F. Hexagon Socket Cap Screw 1¼" long	46	381X.113	Spring Ring
17	164/06	Lockwasher	47	216/3	Tubing Nut
18	381V.114A	Glut	48	221/3	Tubing Sleeve
19	381X.115	Reset Nut	49	381X.103	Inner Spacer
20	381X.116	Locknut	50	273/302	Roller Journal Bearing (Light) 30 x 62 x 16mm
21	173/12H	½" B.S.F. Hexagon Locknut (Hardened)	51	381X.102	Outer Spacer
22	381X.124A	Operating Spring	52	258/302	Self Journal Bearing (Light) 30 x 62 x 16mm
23	165/0636	5/16" B.S.F. Hexagon Socket Cap Screw 2¼" long	53	121/1040T	Square Key 5/16" sq. x 2½" long
24	164/05	Lockwasher	54	381V.104	Clutch Cup
25	381X.118	Trip Sleeve	55	381X.131	Gear Spacer
26	381X.123B	Reset Bracket	56	104/33	Internal Circlip
27	165/0632	5/16" B.S.F. Hexagon Socket Cap Screw 2" long	57	267/25	Ball Journal Bearing (Medium) 25 x 62 x 17mm
28	164/06	Lockwasher	58	168X.160	Oil Bush
29	165/0510	5/16" B.S.F. Hexagon Socket Cap Screw ¾" long	59	381X.111	Locking Pin
30	164/05	Lockwasher	60	381X.112	Locking Screw

List of Parts for
PLATE No. 1
(Drawing No.381Z1)

WHEN ORDERING SPARE PARTS ALWAYS QUOTE THE SERIAL NUMBER OF THE ATTACHMENT

THREADING CLUTCH DRIVE, SECTION 381 MK. I

2¼"–6, 2¼"–6D, 2"–6, 2"–6D BAR MACHINES. 6⅜"–6, 6⅜"–6D CHUCKING MACHINES

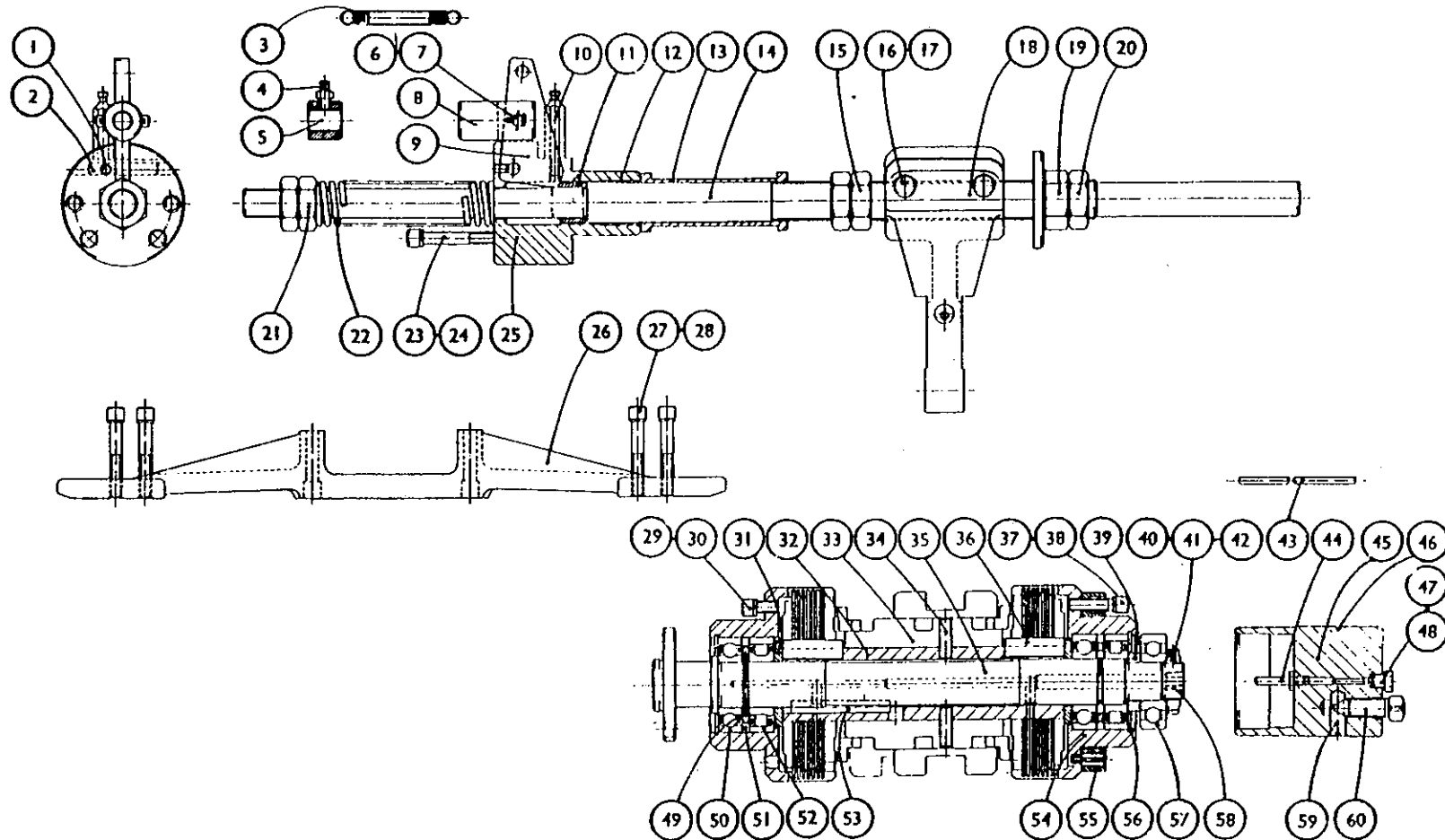

**WICKMAN
MULTI-SPINDLE
AUTOMATICS**

THREADING ATTACHMENT DRIVE SLEEVE, SECTION 382 MK.I
2¼"-6, 2¼"-6D, 2"-6, 2"-6D BAR MACHINES. 6¼"-6, 6¼"-6D CHUCKING MACHINES

INDEX NO.	PART NO.	TITLE	INDEX NO.	PART NO.	TITLE
1	153/04	Soft Pad	12	382V.101	Die-Head Drive Sleeve
2	176/0405	¼" B.S.F. Hexagon Socket Screw, 5/16" long	13	104/39	Internal Circlip
3	150/28	Slotted Locknut	14	382V.104B	Die-Head Drive Housing
4	258/45S2	Ball Journal Bearing 45 x 85 x 19mm (Shielded)	15	155/0620	¾" B.S.F. Hexagon Socket Head Cap Screw 1¼" long
5	382X.106	Spacer	16	154/06	Spring Lockwasher
6	210/1725	Yellow Indicator Washer	17	258/45Z	Ball Journal Bearing 45 x 85 x 19mm
7	212/04S	¼" B.S.F. Nipple — Short Type	18	382X.115	Adaptor Plate
8	104/39	Internal Circlip	19	382X.108	Coupling Stud
9	382X.109	Coupling Pin	20	203/06L	¾" B.S.F. Pinnacle Type Locknut
10	154/05	Spring Lockwasher			
11	155/0512	5/16" B.S.F. Hexagon Socket Head Cap Screw ¼" long			

List of Parts for
PLATE No.2
(Drawing No.382V1)

WHEN ORDERING SPARE PARTS ALWAYS QUOTE THE SERIAL NUMBER OF THE ATTACHMENT

THREADING ATTACHMENT DRIVE SLEEVE, SECTION 382 MK. I

2½"–6, 2¼"–6D, 2"–6, 2"–6D BAR MACHINES. 6⅜"–6, 6⅝"–6D CHUCKING MACHINES

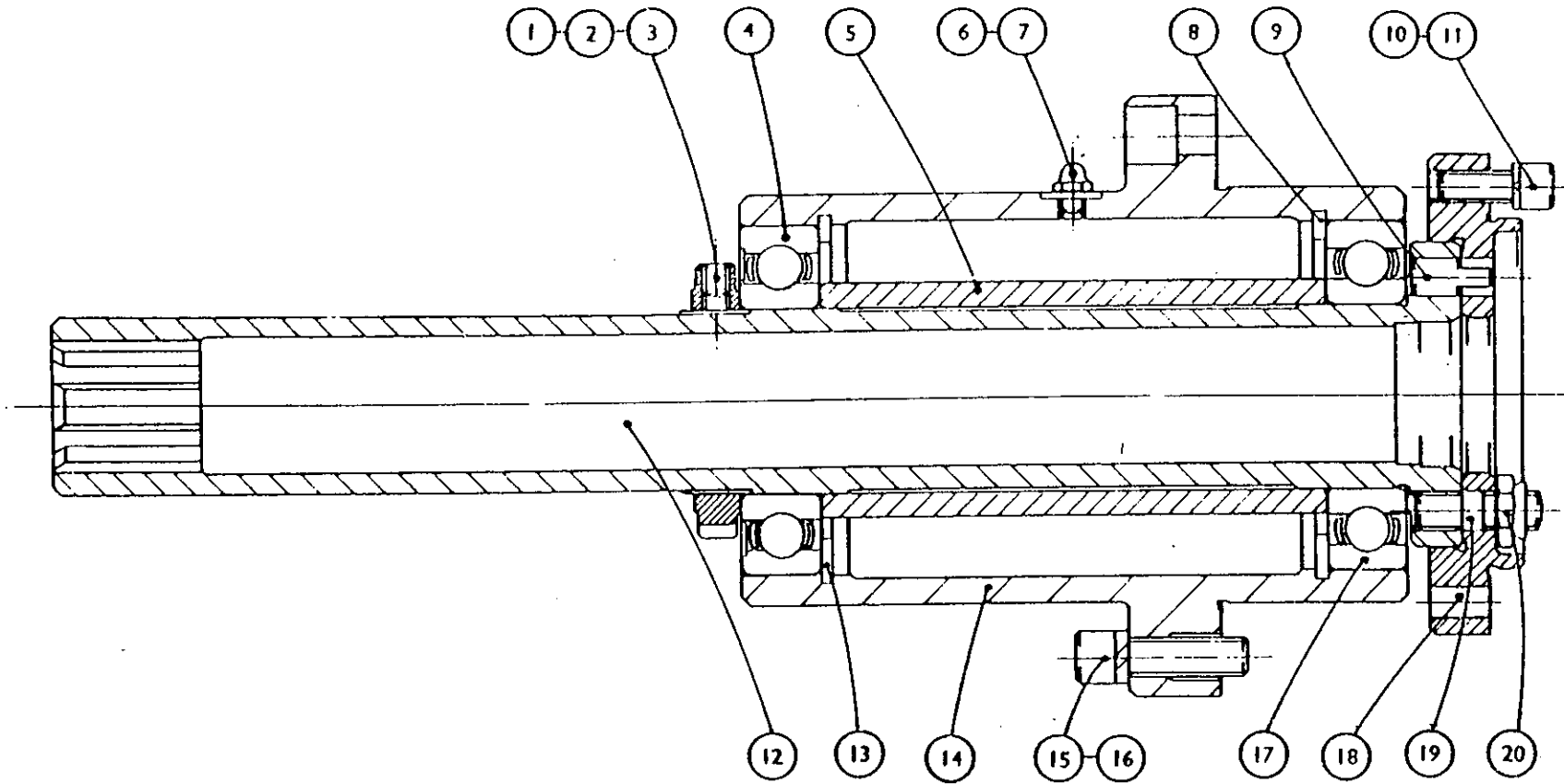

PLATE No. 2
(Drawing No. 382V1)

**WICKMAN
MULTI-SPINDLE
AUTOMATICS**

PARTS COMMON TO THREADING ATTACHMENT, SECTION 386 MK 1 STATIONS 3, 4, 5 & 6

2¼" -6, 2¼" -6D, 2" -6, 2" -6D BAR MACHINES. 6¼" -6, 6¼" -6D CHUCKING MACHINES

INDEX NO.	PART NO.	TITLE	INDEX NO.	PART NO.	TITLE
1	153/05	Soft Pad	10	210/1725	Yellow Indicator Washer
2	176/0506	5/16" B.S.F. Hexagon Socket Set Screw ¾" long	11	386V.113	Threading Spindle Housing
3	386X.121	Locking Ring	12	386Y.119	Threading Spindle
4	25A/50	Ball Journal Bearing 50 x 90 x 20 mm	13	386X.120	Clamp Washer
5	151/50	Slotted Locknut	14	150/30	Slotted Locknut
6	155/0506	5/16" B.S.F. Hexagon Socket Head Cap Screw ¾" long	15	176/0405	¼" B.S.F. Hexagon Socket Set Screw 5/16" long
7	386X.114	Drive Pin	16	153/04	Soft Pad
8	386X.112	Thrower Ring	17	586X.124	Sleeve
9	212/04S	¼" B.S.F. Nipple-Short Type	18	586X.129	Push Rod Spring
			19	586X.127	Locknut

List of Parts for
PLATE No.3
(Drawing No.386Y1)

WHEN ORDERING SPARE PARTS ALWAYS QUOTE THE SERIAL NUMBER OF THE MACHINE

**PARTS COMMON TO THREADING ATTACHMENT, SECTION 386 MK I
STATIONS 3, 4, 5 & 6**

2½"–6, 2¼"–6D, 2"–6, 2"–6D BAR MACHINES. 6⅜"–6, 6⅝"–6D CHUCKING MACHINES

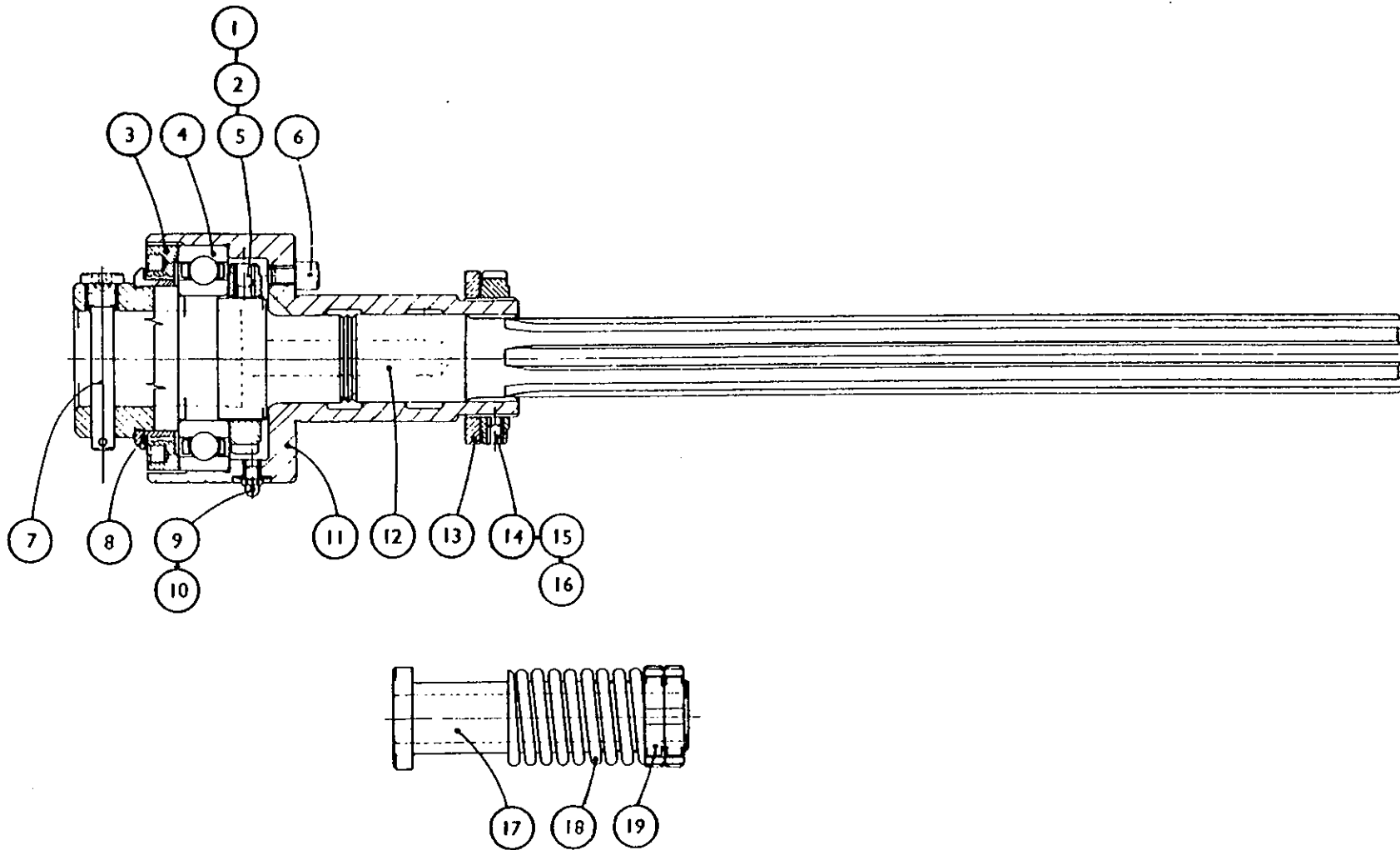

**WICKMAN
MULTI-SPINDLE
AUTOMATICS**

**THREADING ATTACHMENT EXTRA PARTS, SECTION 386A MK.I STATIONS 4 & 5
2¼"-6, 2¼"-6D, 2"-6, 2"-6D BAR MACHINES. 6¼"-6, 6¼"-6D CHUCKING MACHINES**

INDEX NO.	PART NO.	TITLE	INDEX NO.	PART NO.	TITLE
1	386X.127	Push Rod	11	203/05	5/16" B.S.F. Pinnacle Type Hexagon Nut
2	386X.134	Push Rod Clamp	12	176/0514	5/16" B.S.F. Hexagon Socket Set Screw Cup Point 7/8" long
3	195/0620H	¾" B.S.F. Naylor Collar Head Screw 1¼" long	13	386X.145	Return Spring
4	386X.128	Pull Rod	14	154/06	Spring Lockwasher
5	388X.105	Trip Clamp	15	155/0640	¾" B.S.F. Hexagon Socket Head Cap Screw 2½" long
6	195/0616H	¾" B.S.F. Naylor Collar Head Screw 1" long	16	508X.208	Spring Anchor (Long)
7	386V.125A	Attachment Bracket	17	386X.126	Slide Bracket
8	386X.148	Spring Anchor	18	173/08L	½" B.S.F. Hexagon Locknut
9	154/08	Spring Lockwasher			
10	165/0832	½" B.S.F. Hexagon Socket Head Cap Screw 2" long			

List of Parts for
PLATE No.4
(Drawing No.386V2)

WHEN ORDERING SPARE PARTS ALWAYS QUOTE THE SERIAL NUMBER OF THE MACHINE

**THREADING ATTACHMENT EXTRA PARTS, SECTION 386A MK. I
STATIONS 4 & 5**

2½"–6, 2½"–6D, 2"–6, 2"–6D BAR MACHINES. 6½"–6, 6½"–6D CHUCKING MACHINES

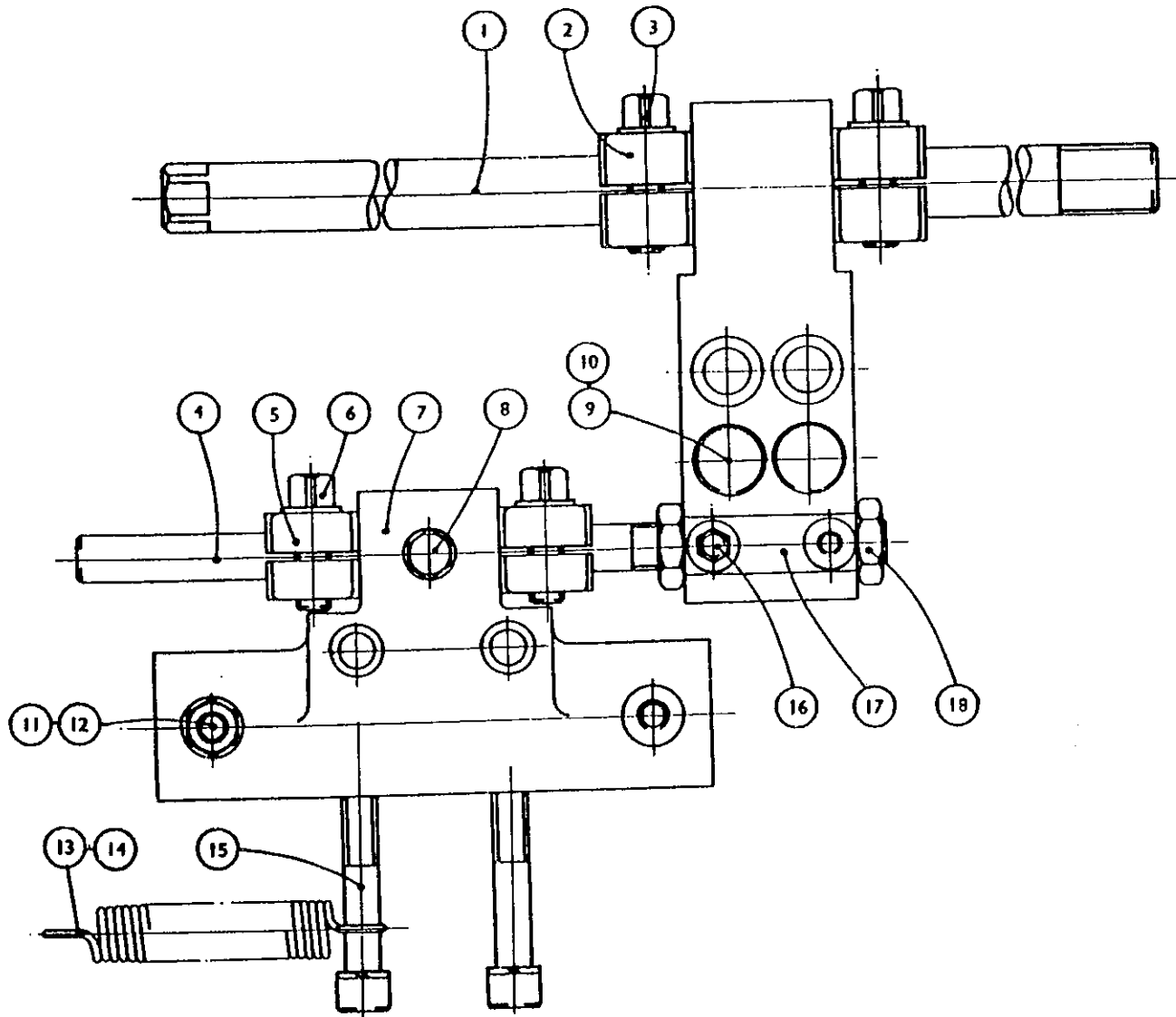

**PLATE No. 4
(Drawing No. 386V2)**

**WICKMAN
MULTI-SPINDLE
AUTOMATICS**

**THREADING ATTACHMENT, SECTION 388D MK.1, EXTRA PARTS, STATIONS 3 & 6
2¼" -6, 2¼" -6D, 2" -6, 2" -6D, BAR MACHINES 6¼" -6, 6¼" -6D CHUCKING MACHINES**

INDEX NO.	PART NO.	TITLE
1	203/05	5/16" B.S.F. Hexagon Pinnacle Type Nut
2	176/0514	5/16" B.S.F. Hexagon Socket Set Screw Cup Point ¾" long
3	386V.129A	Attachment Bracket
4	186X.119	Spring Anchor
5	155/0628	¾" B.S.F. Hexagon Socket Head Cap Screw 1¾" long
6	154/06	Spring Lockwasher
7	MSE.330	Extension Spring
8	186X.119	Spring Anchor
9	386X.130	Spring Anchor Sleeve

**List of Parts for
PLATE No.6
(Drawing No.386V3)**

WHEN ORDERING SPAHE PARTS ALWAYS QUOTE THE SERIAL NUMBER OF THE MACHINE

**THREADING ATTACHMENT, SECTION 386D MK. I, EXTRA PARTS
STATIONS 3 & 6**

2¼"–6, 2¼"–6D, 2"–6, 2"–6D, BAR MACHINES 6⅝"–6, 6⅝"–6D CHUCKING MACHINES

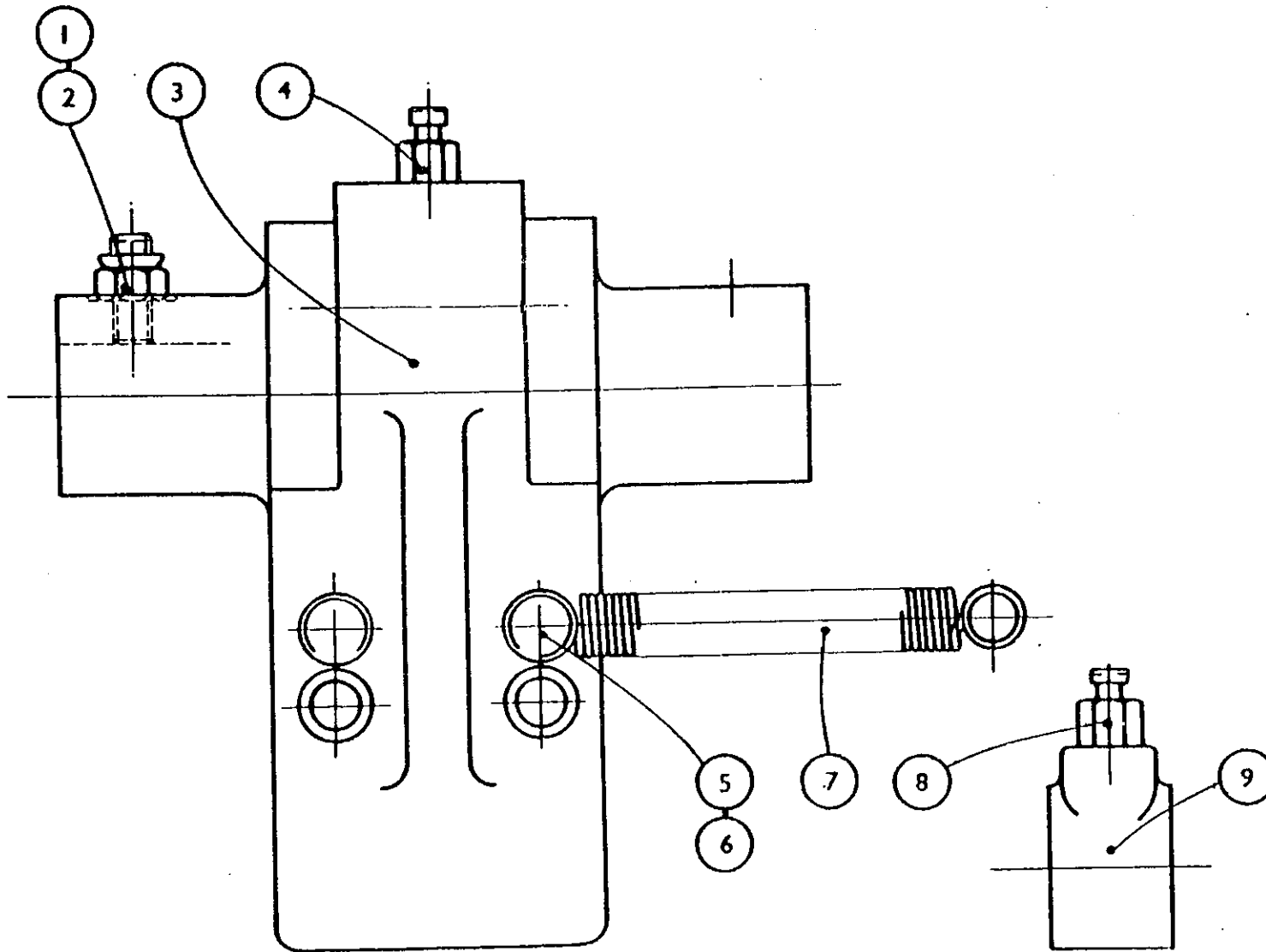

**PLATE No. 5
(Drawing No. 386V3)**

**WICKMAN
MULTI-SPINDLE
AUTOMATICS**

**LIMIT SWITCH SECTION 186F
FOR CHECKING THREADING ATTACHMENT RETURN**

2¼"-6, 2½"-6D, 2"-6, 2"-6D BAR MACHINES. 6¾"-6, 6¾"-6D CHUCKING MACHINES

INDEX NO.	PART NO.	TITLE	INDEX NO.	PART NO.	TITLE
1	186X.150A	Switch Base	12	203/06	¾" B.S.F. Self Locking Nut
2	MSC.140	Morris Spring	13	155/0616	¾" B.S.F. Hollow Hexagon Cap Screw 1" long
3	158X.124A	Plunger	14	164/06	Spring Lockwasher
4	143/0812B	Grooved Pin ¼" dia. ¾" long	15	186X.153	Stop Plate
5	181AX.108	Link Fork	16	186X.151	Lever
6	173/06L	¾" B.S.F. Hexagon Locknut	17	143/0816B	Grooved Pin ¼" dia. 1" long
7	188X.108	Trip Clamp	18	B63E	Square 'D' Limit Switch
8	195/0512	5/16" B.S.F. Collar Head Screw 5/16" long	19	156/232	2 B.A. Hollow Hexagon Cap Screw 2" long
9	145/176	Compression Spring ¾" o/d 3½" long	20	154/03	Spring Lockwasher
10	186X.152	Operating Rod	21	155/0414	¾" B.S.F. Hollow Hexagon Cap Screw ¾" long
11	167/0636	¾" B.S.F. Hexagon Head Set Screw 2¼" long	22	291/11	Legend Plate
			23	165/404	4BA Round Head Screw ¼" long

**List of Parts for
PLATE No.6
(Drawing No.186V20A)**

WHEN ORDERING SPARE PARTS ALWAYS QUOTE THE SERIAL NUMBER OF THE MACHINE

**WICKMAN
MULTI-SPINDLE
AUTOMATICS**

ARRANGEMENT OF BODY AND SLIDE, SECTION 388 MK.I

2¼"-6, 2¼"-6D, 2"-6, 2"-6D BAR MACHINES. 6½"-6, 6½"-6D CHUCKING MACHINES

INDEX NO.	PART NO.	TITLE	INDEX NO.	PART NO.	TITLE
1	165/0614	¼" B.S.F. Hexagon Socket Head Cap Screw ¾" long	10	194/3	¾" B.S.P. Hexagon Socket Pipe Plug
2	697AY.108C	Slide	11	AD.42	¾" to ½" B.S.P. Reducer
3	388Y.101	Attachment Body	12	195/0616H	¾" B.S.F. Naylor Collar Head Screw 1" long
4	388X.111	Guide Strip Screw	13	388X.105	Trip Clamp
5	388X.110	Guide Strip	14	388X.107	Trip Rod
6	212/04S	¼" B.S.F. Nipple Short Type	15	597BX.128	Trip Bush
7	210/1725	Yellow Indicator Washer	16	388X.109	Trip Rod Nut
8	188/0620	¾" B.S.F. Square Head Set Screw 1¼" long	17	388X.108	Trip Rod Extension
9	-	¾" B.S.P. M. & F. Elbow			

List of Parts for
PLATE No.7
(Drawing No.388Y1)

WHEN ORDERING SPARE PARTS ALWAYS QUOTE THE SERIAL NUMBER OF THE ATTACHMENT .

ARRANGEMENT OF BODY AND SLIDE, SECTION 388 MK. I

2¼"–6, 2¼"–6D, 2"–6, 2"–6D BAR MACHINES 6½"–6, 6½"–6D CHUCKING MACHINES

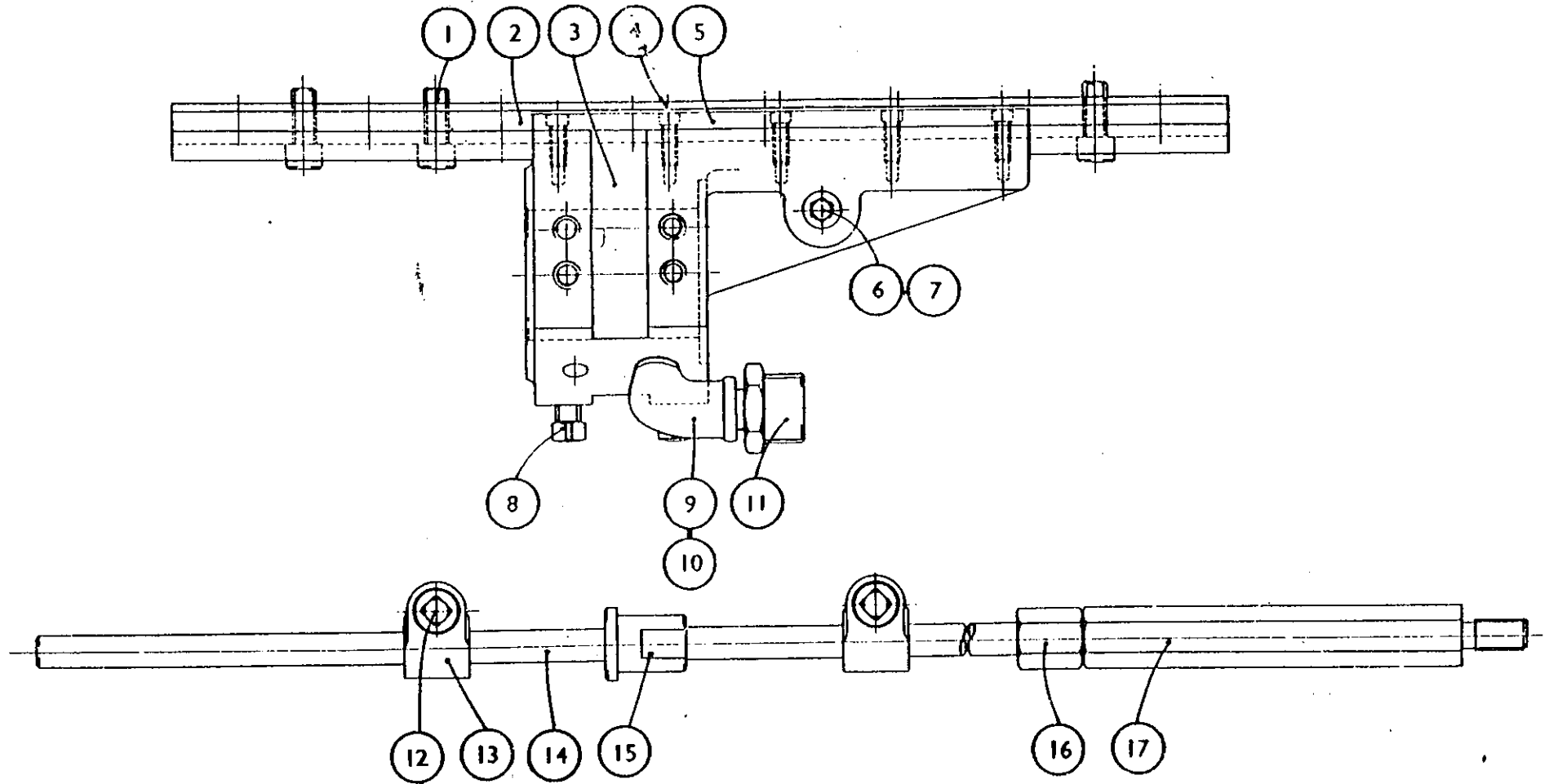

**WICKMAN
MULTI-SPINDLE
AUTOMATICS**

AUXILIARY LONGITUDINAL MOTION, STATION 8, SECTION 389A MK.I
2 1/4"-6, 2 1/4"-6D, 2"-6, 2"-6D BAR MACHINES. 6 1/4"-6, 3 1/4"-6D CHUCKING MACHINES

INDEX NO.	PART NO.	TITLE	INDEX NO.	PART NO.	TITLE
1	389.107B	Packing Strip	31	203/08L	Locknut
2	178/0506	5/16" B.S.F. Socket Set Screw Half Dog Point	32	389X.116	Operating Lever Pivot
3	167/0405	1/4" B.S.F. Hexagon Head Set Screw 5/16" long	33	189AX.130	Spring Anchor
4	389X.112	Slipper	34	389X.105	Link
5	389X.121	Roller Pin	35	289X.124B	Spring
6	195/0620H	3/8" B.S.F. Collar Head Screw 1 1/4" long	36	389X.115	Spring Anchor
7	386X.134	Push Rod Clamp	37	203/06L	3/8" B.S.F. Self Locking Locknut
8	195/0620H	3/8" B.S.F. Collar Head Screw 1 1/4" long	38	389X.122	Sliding Sleeve
9	173/12LH	3/4" B.S.F. Locknut	39	236/161810	Oil Retaining Bush
10	389X.113	Screwed Bush	40	173/10HL	3/8" B.S.F. Locknut
11	155/0516	5/16" B.S.F. Cap Screw 1" long	41	389X.123	Toe Bolt
12	154/05	5/16" Spring Washer	42	141X.116	Slotted Washer
13	389X.111A	Push Rod Guide	43	389X.103	Pivot Pin
14	389X.114	Push Rod	44	389X.121	Roller Pin
15	389Y.110	Pusher Shaft	45	389X.120	Roller
16	389X.117C	Operating Plate	46	155/0716	7/16" B.S.F. Cap Screw 1" long
17	389V.102A	Operating Lever	47	154/07	7/16" Spring Washer
18	121/1024	Key 5/16" square x 1 1/2" long	48	154/04	1/4" Spring Washer
19	389X.104	Glut	49	155/0416	1/4" B.S.F. Cap Screw 1" long
20	153/04	Soft Pad	50	389X.125	Pusher Shaft Key
21	176/0405	1/4" B.S.F. Socket Set Screw 5/16" long	51	203/05L	5/16" B.S.F. Self Locking Nut
22	150/22	Slotted Locknut	52	183/0524	5/16" B.S.F. Square Head Set Screw Taper Point 1 1/2" long
23	389X.119A	Shear Pin Bush	53	155/0662	3/4" B.S.F. Cap Screw 3/4" long
24	124/0536	Parallel Pin 5/32" dia. x 2 1/4" long	54	389Y.101A	Quadrant Lever
25	389X.118	Shear Pin Bush	55	183/0524	5/16" B.S.F. Square Head Set Screw 1 1/2" long
26	236/161810	Oil Bush	56	203/05L	5/16" B.S.F. Self Locking Nut
27	389X.125A	Link Pin	57	164/0404	1/4" B.S.F. Round Head Screw 1/4" long
28	518X.197	Collar	58	389X.106	Scale
29	203/12L	Locknut			
30	130/08	Plain Washer			

List of Parts for
PLATE No.8
(Drawing No.38921)

WHEN ORDERING SPARE PARTS ALWAYS QUOTE THE SERIAL NUMBER OF THE ATTACHMENT

AUXILIARY LONGITUDINAL MOTION, STATION 6, SECTION 389A MK. 1

2¼" - 6, 2½" - 6D, 2" - 6, 2" - 6D BAR MACHINES 6½" - 6, 6¾" - 6D CHUCKING MACHINES

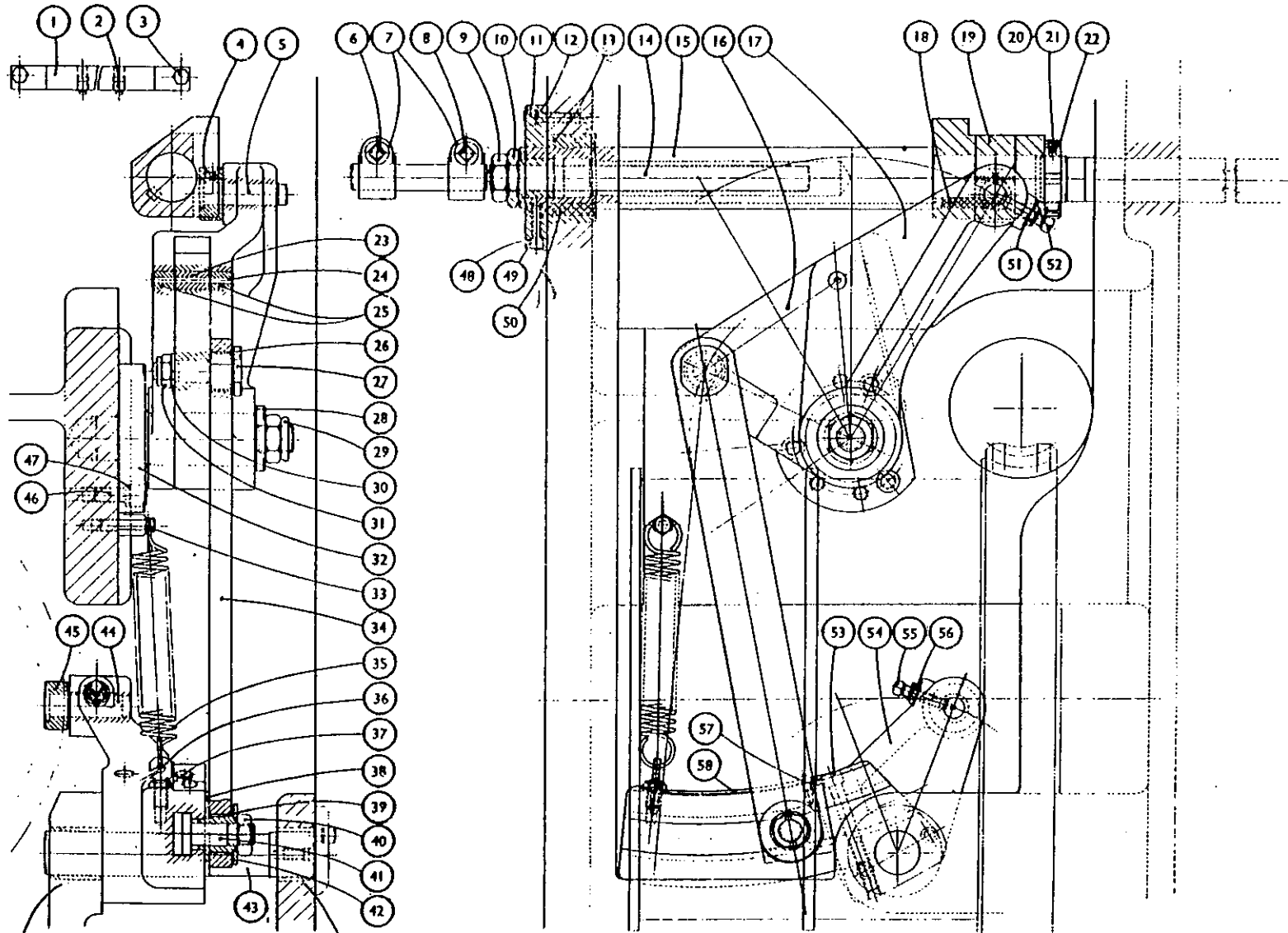

Z36/202424

Z36/202416

PLATE No. 8
(Drawing No. 389Z1)

**WICKMAN
MULTI-SPINDLE
AUTOMATICS**

AUXILIARY LONGITUDINAL MOTION, STATION 3, SECTION 389A MK.I
2¼"-6, 2½"-6D, 2"-6, 2"-6D BAR MACHINES. 6½"-6, 6½"-6D CHUCKING MACHINES

INDEX NO.	PART NO.	TITLE	INDEX NO.	PART NO.	TITLE
1	150/22	Slotted Locknut	30	389X.118	Shear Pin Bush
2	153/04	Soft Pad	31	389X.116	Operating Lever Pivot
3	176/0405	5/16" B.S.F. Socket Set Screw Half Dog point ¾" long	32	578X.197	Collar
4	389X.133	Glut	33	203/12L	¾" B.S.F. Self-Locking Nut
5	121/124	Key 5/16" sq. x 1½" long	34	389X.125A	Link Pin
6	389V.132A	Operating Lever	35	236/161810	Oil Retaining Bush
7	389X.117C	Operating Plate	36	130/08	Plain Washer
8	389Y.110	Pusher Shaft	37	203/08L	½" B.S.F. Self-Locking Nut
9	389X.114	Push Rod	38	389X.135	Link
10	389X.111A	Push Rod Guide	39	189AX.130	Spring Anchor
11	154/05	Spring Washer	40	289X.124B	Spring
12	155/0516	5/16" B.S.F. Cap Screw 1" long	41	155/0716	7/16" B.S.F. Cap Screw 1" long
13	389X.113	Screwed Bush	42	154/07	Spring Washer
14	173/12LH	¾" B.S.F. Locknut	43	389X.121	Roller Pin
15	195/0620H	¾" B.S.F. Collar Head Screw 1¼" long	44	389X.120	Roller
16	386X.134	Push Rod Clamp	45	389X.115	Spring Anchor
17	195/0620H	¾" B.S.F. Collar Head Screw 1¼" long	46	203/06L	¾" B.S.F. Self-Locking Nut
18	389X.107B	Packing Strip	47	164/0404	¾" B.S.F. Round Head Screw ¼" long
19	178/0506	5/16" B.S.F. Socket Set Screw Half Dog point ¾" long	48	389X.136	Scale
20	167/0405	½" B.S.F. Hexagon Head Set Screw 5/16" long	49	389Y.131A	Quadrant Lever
21	389X.121	Roller Pin	50	183/0524	5/16" B.S.F. Square Head Set Screw 1½" long
22	389X.112	Slipper	51	203/05L	5/16" B.S.F. Self-Locking Nut
23	183/0524	5/16" B.S.F. Square Head Set Screw 5/16" long	52	389X.134	Pivot Pin
24	203/05L	5/16" B.S.F. Self-Locking Nut	53	173/10LH	¾" B.S.F. Locknut
25	155/0416	½" B.S.F. Cap Screw 1" long	54	141X.116	Slotted Washer
26	389X.126	Pusher Shaft Key	55	236/161810	Oil Retaining Bush
27	154/04	Spring Washer	56	389X.122	Sliding Sleeve
28	389X.119A	Shear Pin Bush	57	389X.123	Fee-Bolt
29	124/0536	Parallel Pin 5/32" dia. 2¼" long	58	155/0620	¾" B.S.F. Cap Screw 1¼" long

List of Parts for
PLATE No.9
(Drawing No.389Z2)

WHEN ORDERING SPARE PARTS ALWAYS QUOTE THE SERIAL NUMBER OF THE ATTACHMENT

AUXILIARY LONGITUDINAL MOTION, STATION 3, SECTION 389A MK. I

2½"—6, 2½"—6D, 2"—6, 2"—6D BAR MACHINES. 6½"—6, 6½"—6D CHUCKING MACHINES

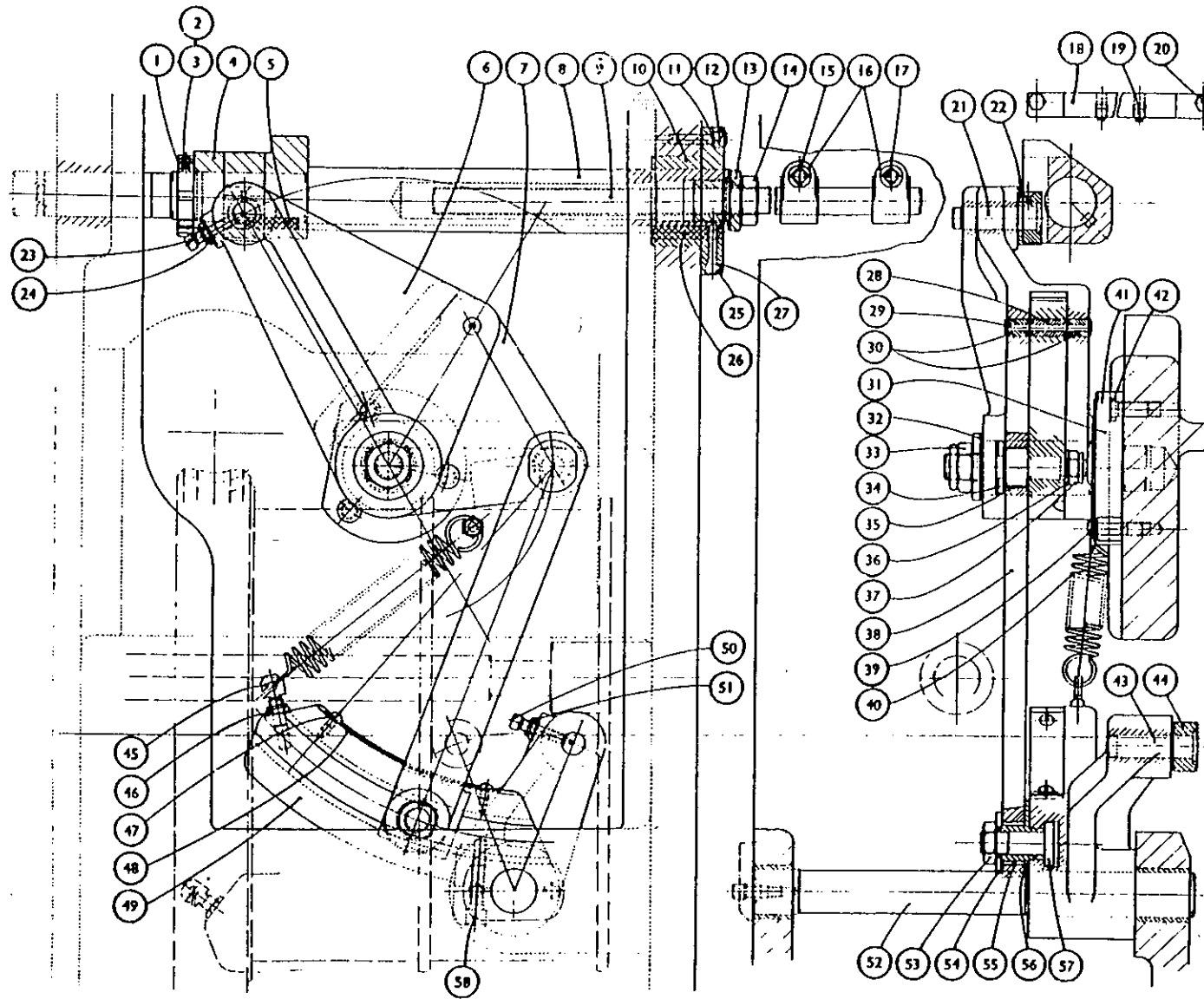

**WICKMAN
MULTI-SPINDLE
AUTOMATICS**

HIGH SPEED DRILL. DRIVE, SECTION 390A MK.I
2¼"-6, 2¼"-6D, 2"-6, 2"-6D, 6¾"-6, 6¾"-6D MACHINES

INDEX NO.	PART NO.	TITLE	INDEX NO.	PART NO.	TITLE
1	210 2525	Yellow Indicator Washer	20	154/06	Spring Lockwasher
2	212/18	¼" B.S.P. Grease Nipple	21	390X.131	Nut
3	390X.119	Bearing Spacer	22	390X.120	Anchor Pin
4	390V.125A	Drill Drive Housing	23	258/40	Ball Journal Bearing (Light), 40 x 80 x 18mm
5	390V.126A	Idler Bracket	24	390X.132	Key
6	390X.116	Idler Spacer	25	151/40	Slotted Locknut
7	390X.118	Idler Pin	26	-	Steel Rivet 5/32" dia. ¾" long
8	390X.116	Idler Spacer	27	176/0405	¼" B.S.F. Hexagon Socket Set Screw Cup Point 5/16" long
9	104/29	Internal Circlip	28	153/04	Soft Pad
10	258/25Z	Ball Journal Bearing (Light), 25 x 52 x 15mm	29	390X.129	Splined Shaft
11	130/12	Washer	30	188/0636	¾" B.S.F. Square Head Set Screw 2¼" long
12	203/12L	¾" B.S.F. Pinnacle Locknut	31	155/0644	¾" B.S.F. Hexagon Socket Head Cap Screw 2¼" long
13	390X.117	Idler Gear	32	590X.110	Pad Bush
14	390X.128	Drive Steeve	33	590X.109	Pad Nut
15	390X.122	Bearing Nut	34	188/0632	¾" B.S.F. Square Head Set Screw 2" long
16	257/40	Ball Journal Bearing (Medium) 40 x 90 x 23mm	35	173/06H	¾" B.S.F. Hexagon Nut (Hardened)
17	155/0620	¾" B.S.F. Hexagon Socket Head Cap Screw 1¼" long			
18	154/06	Spring Lockwasher			
19	155/0510	5/16" B.S.F. Hexagon Socket Head Cap Screw ¾" long			

List of Parts for
PLATE No.10
(Drawing No.390Y2)

WHEN ORDERING SPARE PARTS ALWAYS QUOTE THE SERIAL NUMBER OF THE ATTACHMENT

HIGH SPEED DRILL. DRIVE, SECTION 390A MK I

2½"–6, 2¼"–6D, 2"–6, 2"–6D, BAR MACHINES 6½"–6, 6¾"–6D CHUCKING MACHINES

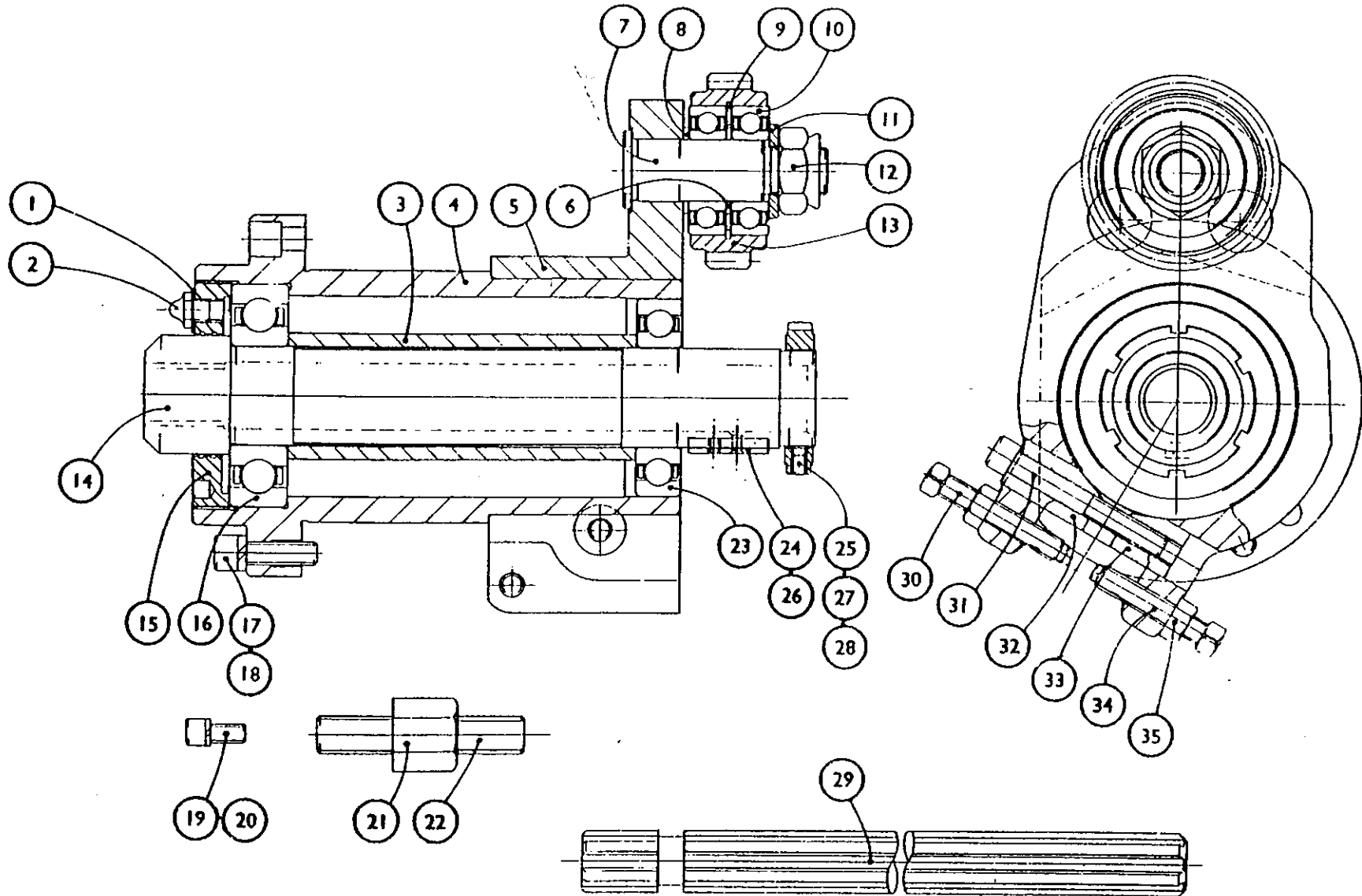

**WICKMAN
MULTI-SPINDLE
AUTOMATICS**

AUXILIARY CROSS SLIDE MOTION-EXTRA PARTS

2 $\frac{1}{4}$ "—6, 2 $\frac{1}{4}$ "—6D, 2"—6, 2"—6D BAR MACHINES
6 $\frac{1}{2}$ "—6, 6 $\frac{1}{2}$ "—6D CHUCKING MACHINES

INDEX NO.	PART NO.	TITLE
1	236/182216	Oil Retaining Bush.
2	393X.120	Connecting Link.

List of Parts for
(Drawing No. 393X2)

INDEX NO.	PART NO.	TITLE
1	170/0632	$\frac{1}{2}$ " B.S.F. Hexagon Head Bolt 2" long.
2	393V.140	Link.
3	393X.141	Spacing Washer.
4	236/182212	Oil Retaining Bush.

List of Parts for
(Drawing No. 393V3)

AUXILIARY CROSS SLIDE MOTION-EXTRA PARTS

2¼"---6, 2¼"---6D, 2"---6, 2"---6D BAR MACHINES

6½"---6, 6½"---6D CHUCKING MACHINES

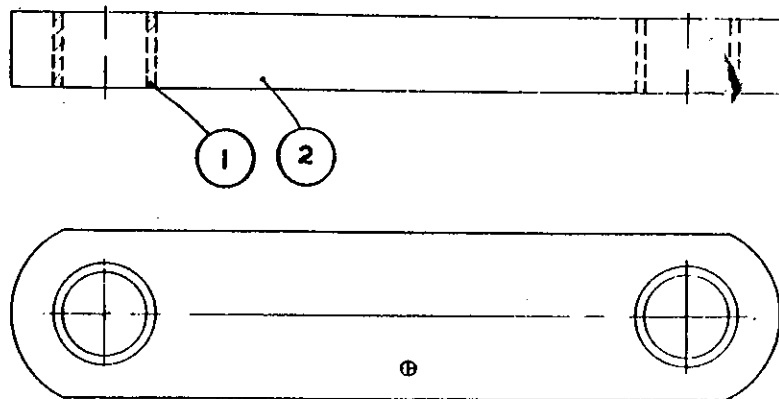

SECTION N° 393A MK I

(Drawing No. 393X2)

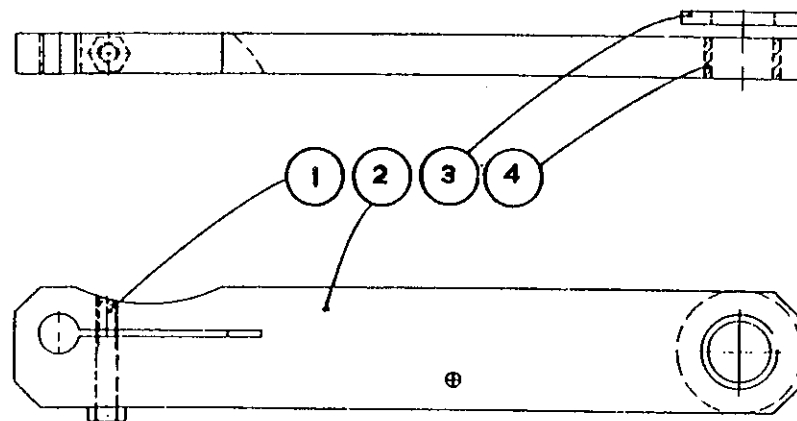

SECTION N° 392B MK I

(Drawing No. 393V3)

390 V 5 SYNCHRONOUS DRIVE
2 1/4" - 6, 2 1/4" - 6D BAR MACHINES. SECTION 390J

INDEX NO.	PART NO.	TITLE
1	390X.142	Drive Sleeve
2	212/04S	1/4" BSF Grease Nipple
3	210/1725	Lubricator Washer
4	290X.144	Bearing Nut
5	258/40	40m/m Ball Journal
6	-	Screw into tapped holes provided in body flange
7	155/0620	3/8" BSF Socket Head Cap Screw 1 1/4" long
8	154/06	3/8" Spring Washer
9	390V.141	Drive Housing
10	290X.143	Bearing Spacer
11	258/35	36m/m Ball Journal
12	122/1228T	3/8" x 1/4" Key 1 1/4" long
13	190X.145	Gear Spacer
14	150/22	1 3/8" Slotted Locknut
15	153/04	1/4" Soft Pad
16	176/0405	1/4" BSF Socket Set Screw, Cup Point 5/16" long
17	-	NOTE: Fitted Key & Shaft must be inspected with Gauge MPG 859
18	-	For Application Drawing and Gears available see 390Z11

List of Parts for
 Plate No.14
 (Drawing No.390V5)

WHEN ORDERING SPARE PARTS ALWAYS QUOTE THE INSPECTION NUMBER OF THE MACHINE

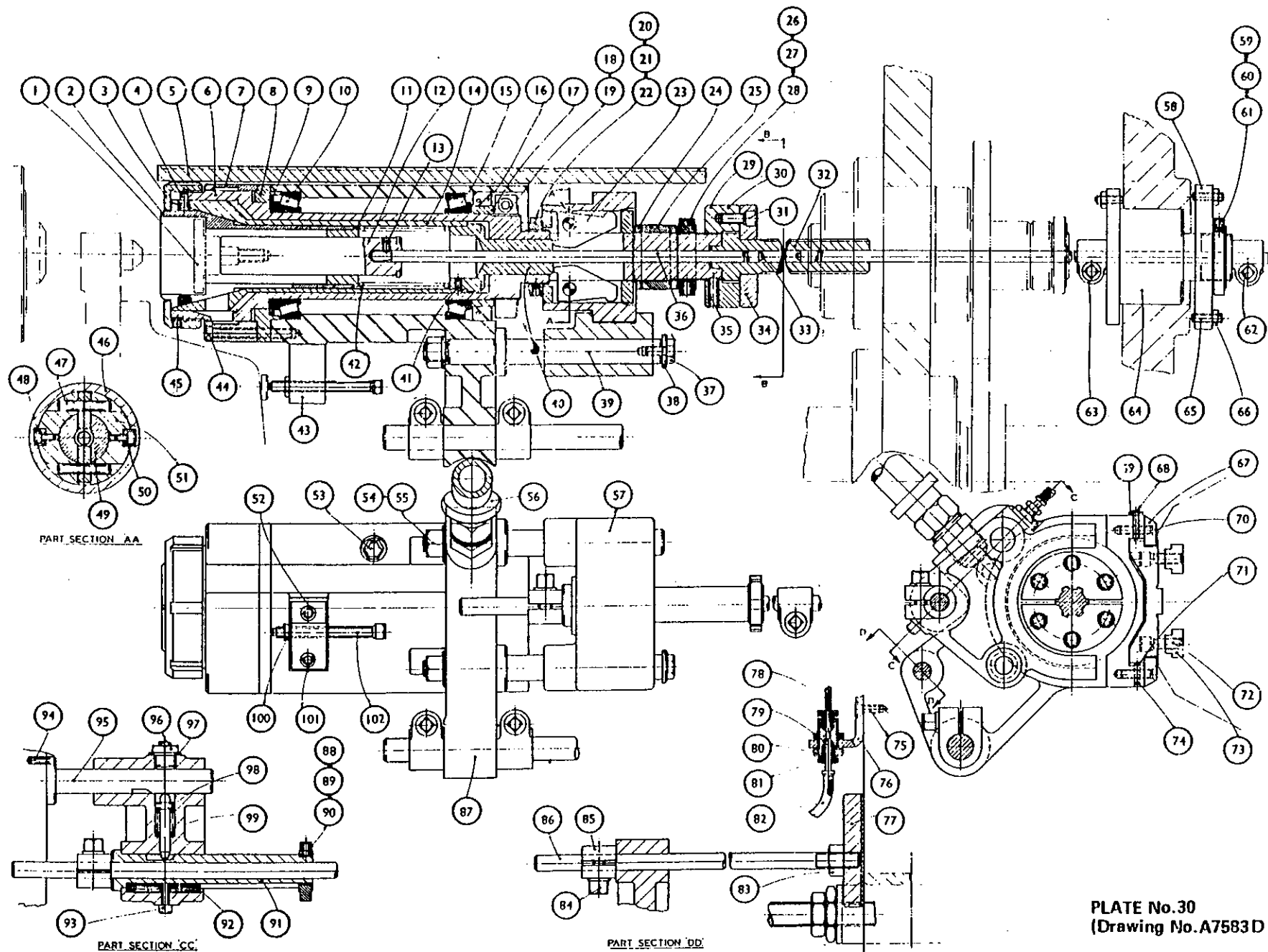

PLATE No. 30
 (Drawing No. A7583D)

PICK-UP ATTACHMENT
 2 1/4"-6 MACHINES

**A7584 ARRANGEMENT OF COLLET OPERATING MECHANISM
6TH STATION PICK UP ATTACHMENT (ALSO 3RD STATION)**

2¼"-6 BAR MACHINES

INDEX NO.	PART NO.	TITLE
1	D53561	Swivel Pin
2	388X.105	Trip Clamp
3	D57333	Connection
4	173/08L	½" BSF Hexagon Locknut
5	D58686	Operating Rod
6	195/0616	¾" BSF Clamping Collar Head Screw 1" long
7	130/08	½" dia. Flat Washer
8	203/08	½" BSF Self Locking Nut
9	B8782	Collet Operating Lever
10	173/07L	7/16" BSF Hexagon Locknut
11	D58685	Stop Bolt
12	55986	Tee Nut
13	130/05	5/16" dia. Flat Washer
14	169/0514	5/16" BSF Hexagon Head Set Screw 7/8" long
15	D71443	Cam Dog
16	B8787A	Cam Drum
17	D58684	Roller Pin
18	126/0620	3/16" dia. Parallel Hardened Dowel 1¼" long
19	D58683	Roller
20	130/05	5/16" dia. Flat Washer
21	173/05	5/16" BSF Hexagon Nut
22	D55985	Taper Pin
23	D58688	Shaft
24	C19841A	Support Bracket
25	155/0740	7/16" BSF Socket Head Cap Screw 2½" long
26	101/18	1½" dia. External Circlip
27	B8788/1	Cover
	B8788/2	Cover (3rd Position only)
28	155/0412	½" BSF Socket Head Cap Screw ¾" long
29	D58687	Key
30	155/0856	½" BSF Socket Head Cap Screw 3¼" long
31	155/0408	½" BSF Socket Head Cap Screw ½" long

List of Parts for
PLATE No.31
(Drawing No.A7584)

WHEN ORDERING SPARE PARTS ALWAYS QUOTE THE INSPECTION NUMBER OF THE MACHINE

SPINDLE LOCATION UNIT
6 1/4"-6 CHUCKING MACHINES

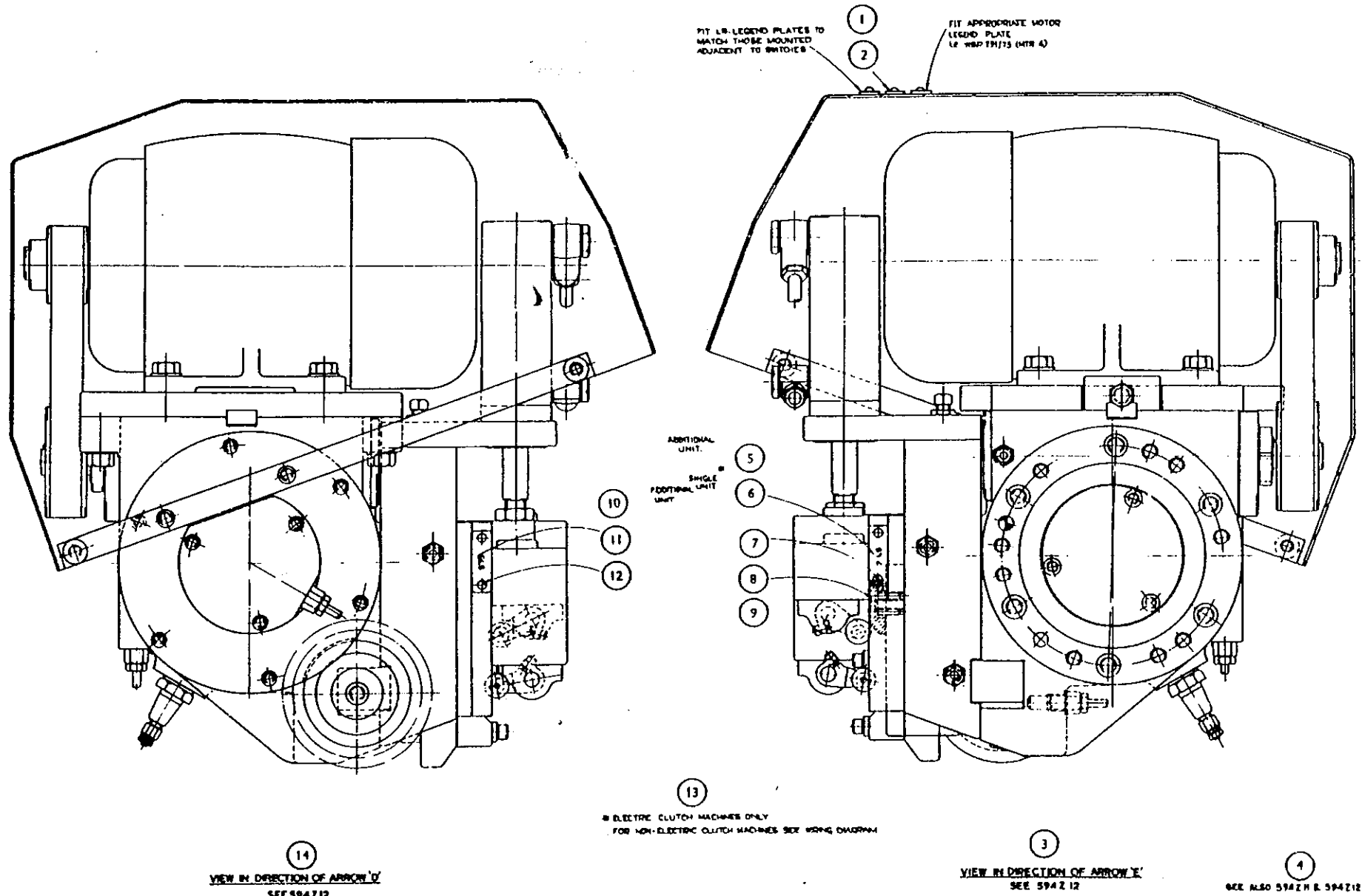

14
 VIEW IN DIRECTION OF ARROW 'D'
 SEE 594212

3
 VIEW IN DIRECTION OF ARROW 'E'
 SEE 594212

4
 SEE ALSO 594212 & 594215

13
 ■ ELECTRIC CLUTCH MACHINES ONLY
 ■ FOR NON-ELECTRIC CLUTCH MACHINES SEE WIRING DIAGRAM

A 7583D PICK UP ATTACHMENT

2 1/4" - 6 BAR MACHINES

INDEX NO.	PART NO.	TITLE	INDEX NO.	PART NO.	TITLE
1	D57752A	Ejector	52	155/0516	5/16" BSF Socket Head Cap Screw 1" long
2	B8784A	Collar	53	212/18	1/4" BSP Grease Nipple
3	D58663B	Collar Retainer	54	130/08	1/2" Dia. Flat Washer
4	D19710	Pin	55	173/08	1/2" BSF Hexagon Nut
5	B8786B	Slide	56	569X/222B	1 Grillex Hose Assembly
6	B8783C	Drive Shaft	57	B877	Clot
7	C22246A	Coilant Gland	58	D586	Clamp
8	C38455	End Plate	59	176/0405	1/2" BSF Socket Set Screw 5/16" long - cup point
9	D58665	Labyrinth Oil Seal	60	153/04	1/2" Dia. Soft Pad
10	L610 500	Timken Taper Roller Bearing	61	150/24	1/2" BSF Slotted Locknut
11	D58667	Locating Plug	62	195/0516	5/16" BSF Clamping Collar Head Screw 1" long
12	D-8668A	Ejector Plunger	63	188X.108	Trip Clamp
13	176/0405	1/2" BSF Socket Set Screw 5/16" long cup point	64	D58676	Ejector Bung
14	B8785A	Collar Outer Sleeve	65	176/0410	1/2" BSF Socket Set Screw 1" long, cup point
15	L610500	Timken Taper Roller Bearing	66	173/04	1/2" BSF Hexagon Nut
16	75x95x13RA	Weston Oil Seal	67	D58679A	Keeper Plate
17	D103716	Spacer	68	181/214	2BA Socket Set Screw 7/8" long, Half Dog Point
18	155/0414	1/2" BSF Socket Head Cap Screw 7/8" long	69	174/2L	2BA Hexagon Locknut
19	D103737	Slotted Locknut	70	158/0416	1/2" BSF Socket Countersunk Head Screw 1" long
20	176/0405	1/2" BSF Socket Set Screw 5/16" long, cup point	71	D70087	Adjusting Strip
21	153/04	1/2" dia. Soft Pad	72	155/0514	5/16" BSF Socket Head Cap Screw 7/8" long
22	150/26	1 1/8" BSF Slotted Locknut	73	D58678	Tee Nuts
23	D54076B	Collar Closing Toggle	74	326/0410	1/2" dia. Tension Pin 3/8" long
24	D55089	Compensating Washer	75	158/0412	1/2" BSF Socket Countersunk Head Screw 1/2" long
25	D58671	Spacer	76	D58680	Bracket
26	176/0405	1/2" BSF Socket Set Screw 5/16" long, cup point	77	D61391	Cover Plate
27	153/04	1/2" dia. Soft Pad	78	225/3050	3/16" o/d Copper Pipe 60" long
28	150/22	1 1/8" BSF Slotted Locknut	79	221/3	3/16" Tubing Sleeve
29	D54455	Spring Retaining Ring	80	222/1	3/16" Bulkhead Connector
30	D54078	Coupling	81	215/3	3/16" Tubing Nut
31	155/0512	5/16" BSF Socket Head Cap Screw 3/4" long	82	D57781/3	Lubricating Hose Assembly
32	D19842B	Splined Drive Shaft	83	173/08	1/2" BSF Hexagon Nut
33	D53582	Ejector Pin	84	195/0616	1/2" BSF Clamping Collar Head Screw 1" long
34	D54079A	Retainer	85	388X.105	Trip Clamp
35		Unbrako 5/16" BSF Socket Set Screw 3/4" long dog point	86	388X.107	Stop Rod
36	D58672	Front Ejector Rod	87	A7585F	Body
37	167/0510	5/16" BSF Hexagon Head Set Screw 3/8" long	88	179/204	2BA Socket Set Screw 1/2" long
38	D43534	Stop Washer	89	153/42	2BA Soft Pad
39	D58673	Guide Bar	90	150/14	1/2" BSF Slotted Locknut
40	D58670	Locating Plug	91	D54089B	Bush
41	159/406	4BA Socket Countersunk Head Screw 1 1/4" long	92	D54090	Key
42	D58681	Collar Spring	93	155/0410	1/2" BSF Socket Head Cap Screw 5/8" long
43	D64677B	Dead Stop Block	94	126/0612	3/16" dia. Parallel Hardened Dowel 1/2" long
44	155/0436	1/2" BSF Socket Head Cap Screw 2 1/2" long	95	D64678	Guide Bar
45	178/0404	1/2" BSF Socket Set Screw 1 1/4" long, Half Dog Point	96	D54456	Adaptor
46	C18691A	Collar Closing Sleeve	97	130/10	5/8" dia. Flat Washer
47	124/1024	5/16" dia. Parallel Pin 1 1/4" long	98	M5C162	Morris Spring
48	156/206	2BA Socket Head Cap Screw 3/4" long	99	D54088	Plunger
49	B8783C	Drive Shaft	100	173/051	5/16" BSF Hexagon Locknut
50	D54094	Toggle Sleeve Key	101	155/0532	5/16" BSF Socket Head Cap Screw 2" long
51	D54093A	Toggle Sleeve	102	188/0548	5/16" BSF Square Head Set Screw 3" long

List of Parts for
Plate No.30
(Drawing No. A7583D)

WHEN ORDERING SPARE PARTS ALWAYS QUOTE THE INSPECTION NUMBER OF THE MACHINE

HYDRAULIC SLIDING GEAR LOCATION UNIT

6 3/4" - 6H CHUCKING MACHINE

①
PARKER HANNIFIN HYDRAULIC CYLINDER
TO WICKMAN DRG. 584 X 2708, COMPLETE
WITH 1/4 BSP PORT ADAPTOR.

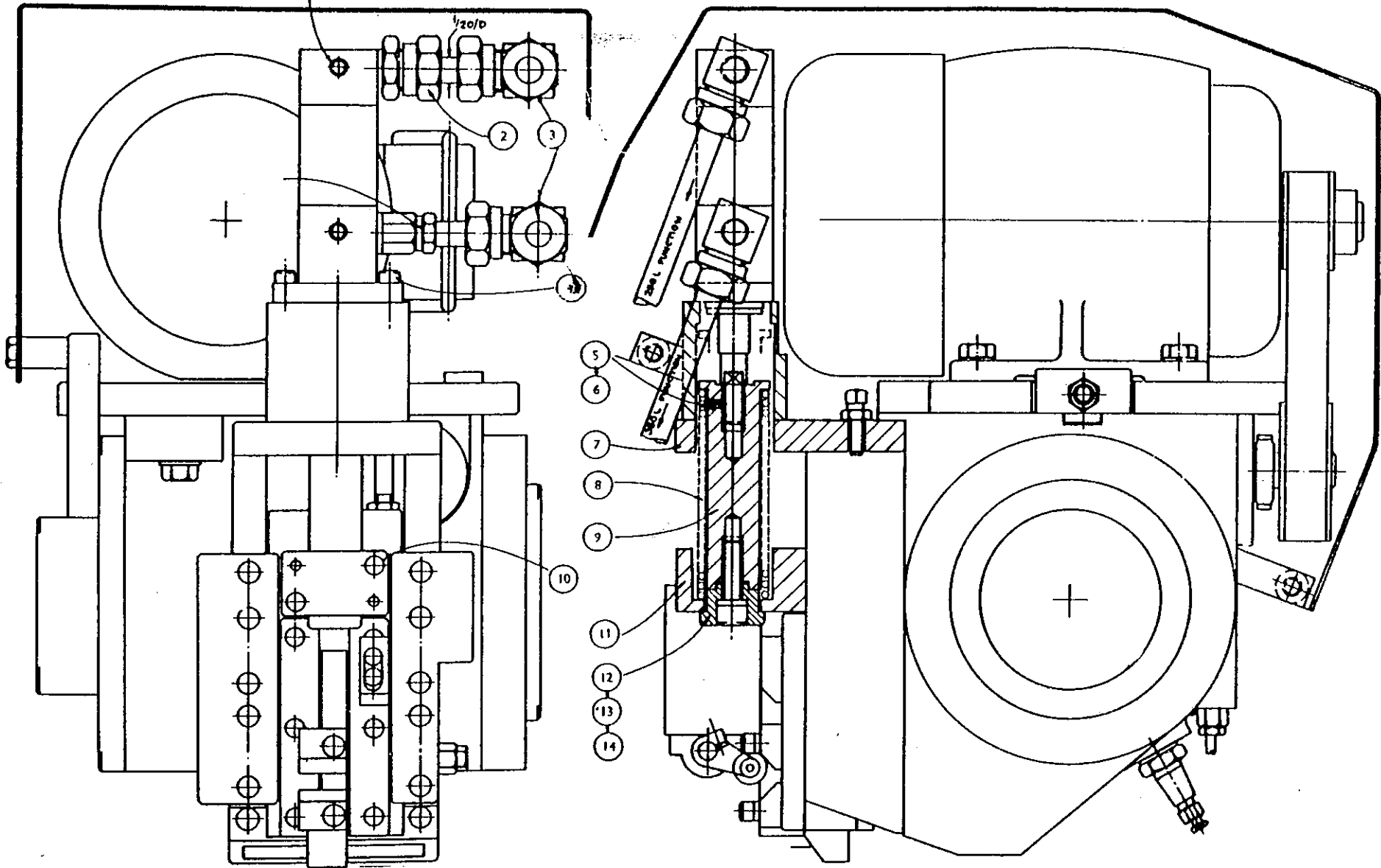

594 Z 15 SLIDING GEAR SPINDLE LOCATION UNIT ASSEMBLY

5 $\frac{1}{2}$ "-6 MACHINE. SECTION 594E

INDEX NO.	PART NO.	TITLE
1	165/404	4 BA Round Head Screw $\frac{1}{4}$ " long
2	291/82	Legend Plate 3MC.
3		View in Direction of Arrow 'E'. See 594 Z 12
4		See also 594 Z 11 and 594 Z 12
5	291/8	Legend Plate 8LS (Double Index Only)
6	291/7	Legend Plate 7LS (Single Index Only)
7	594X.271	Trip Block
8	166/210	2 BA Socket Cap Screw $\frac{5}{8}$ " long
9	164/03	Spring Washer for 2BA Dia.
10	291/9	Legend Plate 9LS (Double Index Only)
11	291/6	Legend Plate 6LS (Single Index Only)
12	166/404	4BA Round Head Set Screw $\frac{1}{4}$ " long
13		Electric Clutch Machines Only For Non-Electric Clutch Machines See Wiring Diagram
14		View in Direction of Arrow 'D' See 594 Z 12

List of Parts for
Plate No. 29
(Drawing No. 594 Z 15)

WHEN ORDERING SPARE PARTS ALWAYS QUOTE THE INSPECTION NUMBER OF THE MACHINE

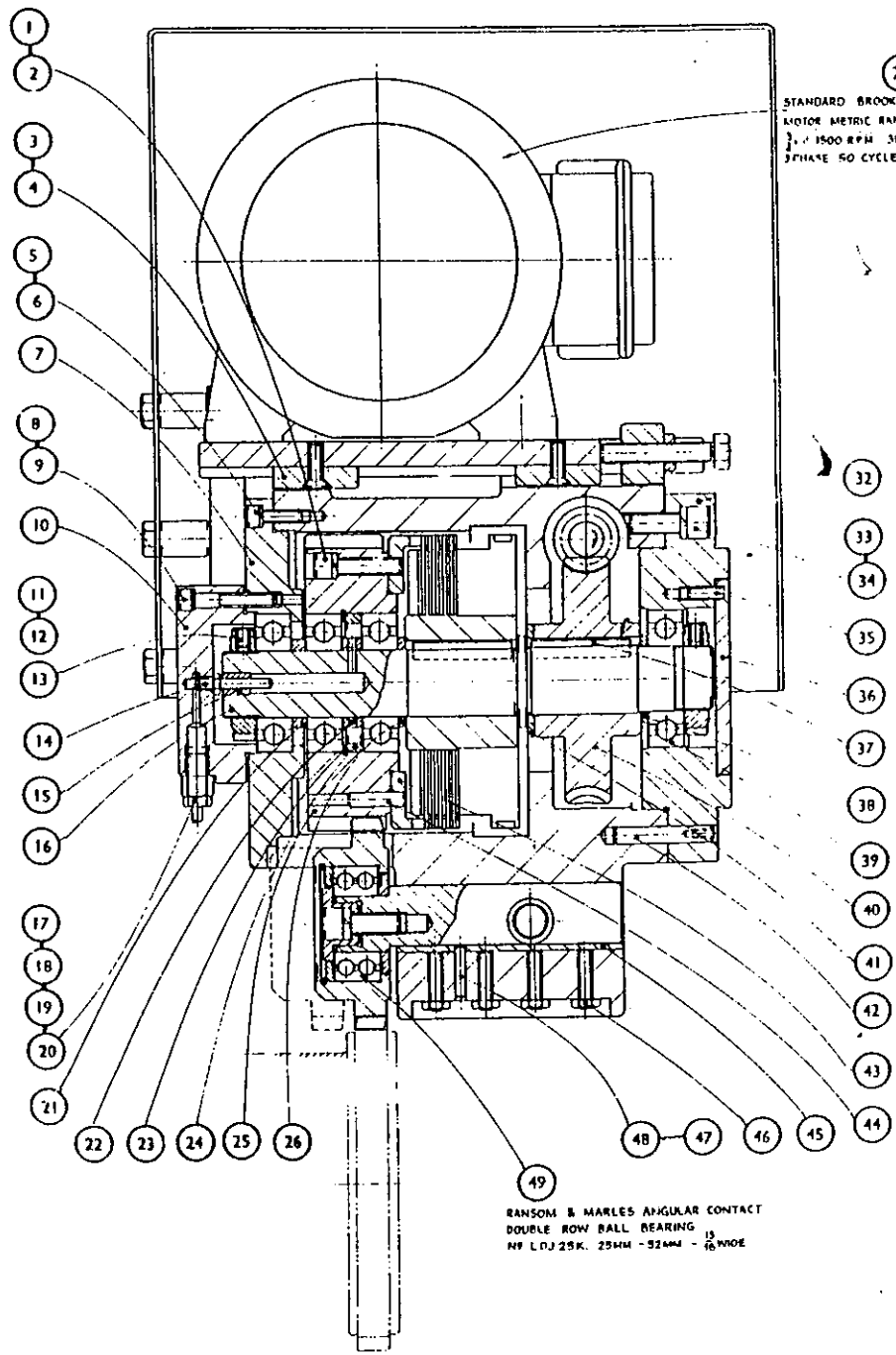

STANDARD BROOK TOTALLY ENCLOSED
MOTOR METRIC RANGE FOOT MOUNTED
1/2 HP 1500 RPM 3PH/440 VOLTS
3PHASE 60 CYCLES MP DROG

RANSOM & MARLES ANGULAR CONTACT
DOUBLE ROW BALL BEARING
N9 L/DJ 25K. 25MM - 52MM - 1 1/8" WIDE

50 SECTION AA
SEE 594 Z 11

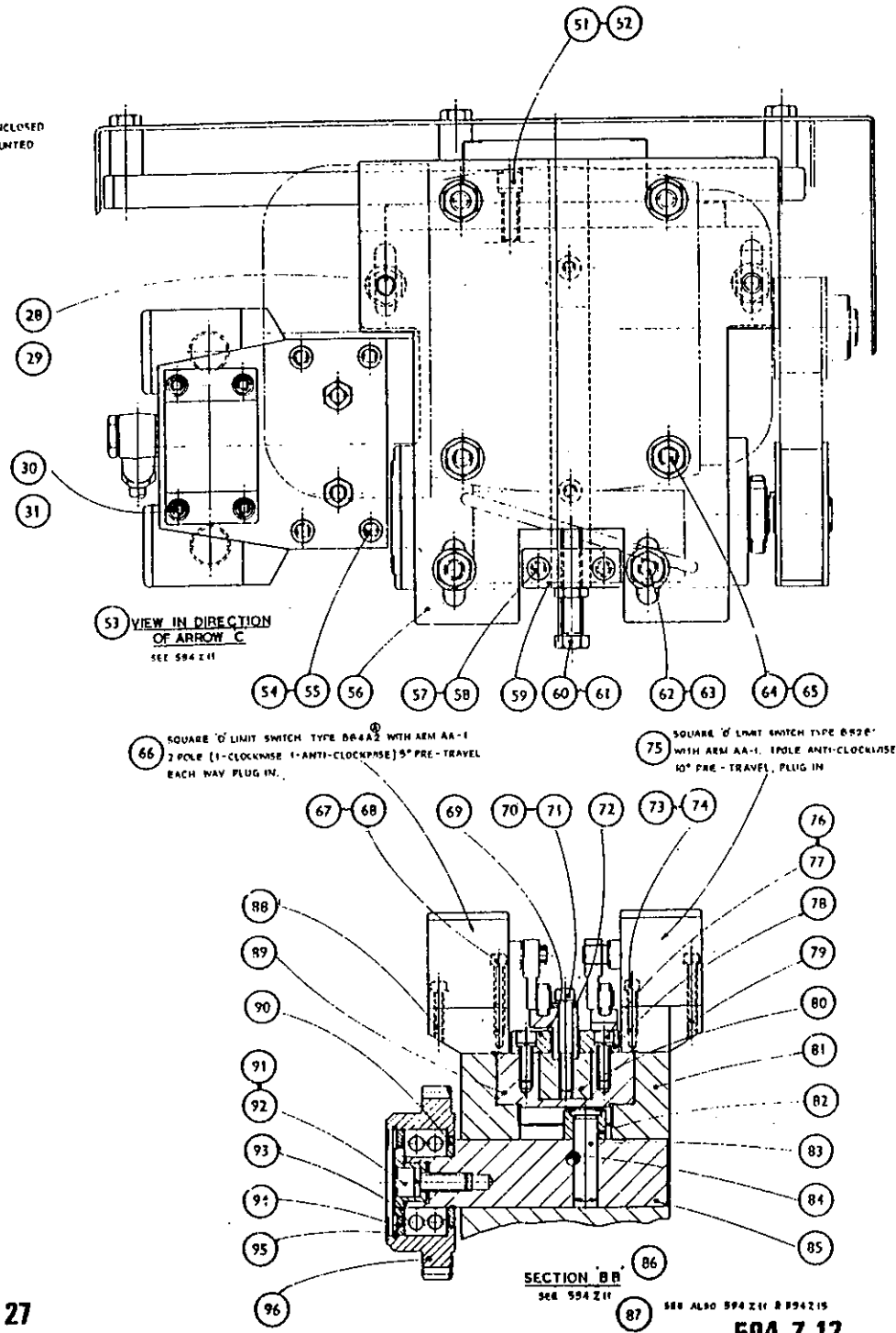

53 VIEW IN DIRECTION
OF ARROW C
SEE 594 Z 11

66 SQUARE 'O' LIMIT SWITCH TYPE B04A2 WITH ARM AA-1
2 POLE [1-CLOCKWISE 1-ANTI-CLOCKWISE] 5° PRE-TRAVEL
EACH WAY PLUG IN.

75 SQUARE 'O' LIMIT SWITCH TYPE B920
WITH ARM AA-1. 1 POLE ANTI-CLOCKWISE
10° PRE-TRAVEL PLUG IN

SECTION BB
SEE 594 Z 11

SEE ALSO 594 Z 11 & 594 Z 15

594 Y 14A ARRANGEMENT OF LOCATION UNIT WHEN OPERATED BY HYDRAULICS
5 1/2" - 6 MACHINE. SECTION 594E

INDEX NO.	PART NO.	TITLE
1		Parker Hannifin Hydraulic Cylinder to Wickman Drawing 594X.2708. Complete with 1/4" B.S.P. Port Adaptor
2	A8/4 SSAR	Stud Standpipe 1/2T - 1/4 B.S.P.
3	A8ER	Equal Elbow 1/2T.
4	155/0416	1/4 B.S.P. Socket Cap Screw 1" long
5	179/203	2BA Socket Set Screw 3/16" long
6	153/42	Soft Pad
7	594V.265A	Mounting Plate
8	594X.267	Compression Spring
9	594X.266A	Cylinder Rod Extension
10	155/0416	1/4" B.S.F. Socket Cap Screw 1" long
11	594X.268	Pusher Block
12	594X.269	End Cap
13	155/0620	3/8" B.S.F. Socket Cap Screw, 1 1/4" long
14	154/06	Spring Washer for 3/8" Dia.
16	A8/4 MSCR	Male Stud Coupling 1/2T - 1/4 B.S.P.
16	PP 45C.	Bonded Washer 1/4" B.S.P.

List of Parts for
 Plate No. 28
 (Drawing No. 594 Y 14A)

WHEN ORDERING SPARE PARTS ALWAYS QUOTE THE INSPECTION NUMBER OF THE MACHINE

594 Z 12 SLIDING GEAR SPINDLE LOCATION UNIT ASSEMBLY

5 $\frac{3}{4}$ " - 6 MACHINE. SECTION 594E

INDEX NO.	PART NO.	TITLE
71	155/0428	Socket Head Cap Screw, $\frac{1}{4}$ " B.S.F. x $1\frac{1}{2}$ " long
72	594X.261	Locator Guide
73	154/03	Spring Washer, for $\frac{3}{16}$ " dia.
74	156/212	Socket Head Cap Screw, 2 B.A. x $\frac{1}{4}$ " long
75	852B1	Square D Limit Switch with arm AA-1. 1 pole anti-clockwise, 10° pre-travel, plug in
76	154/04	Spring Washer, for $\frac{1}{4}$ " dia.
77	155/0412	Socket Head Cap Screw, $\frac{1}{4}$ " B.S.F. x $\frac{3}{4}$ " long
78	594X.272	Locator Guide
79	594X.256	Slide Guide
80	594V.248A	Locator
81	594Y.237	Slide Base
82	594X.230	Roller
83	594X.231	Roller Pin
84	126/0814	Dowel, $\frac{1}{4}$ " dia. x $\frac{7}{8}$ " long
85	594V.223	Sliding Block
86	—	Section "BB", See 594 Z 11
87	—	See also 594 Z 11 & 594 Z 15
88	594X.257	Slide Guide
89	594Y.246	Locator Slide
90	594X.226	Dust Shield
91	154/06	Spring Washer, for $\frac{3}{4}$ " dia.
92	155/0616	Socket Head Cap Screw
93	594X.224	Retaining Cap
94	594X.227	Dust Shield
95	104/29	Internal Circlip, 52mm
96	594X.2288	Sliding Gear, 28 teeth, 47 r.p.m.

List of Parts for
Plate No. 27
(Drawing No. 594 Z 12)

WHEN ORDERING SPARE PARTS ALWAYS QUOTE THE INSPECTION NUMBER OF THE MACHINE

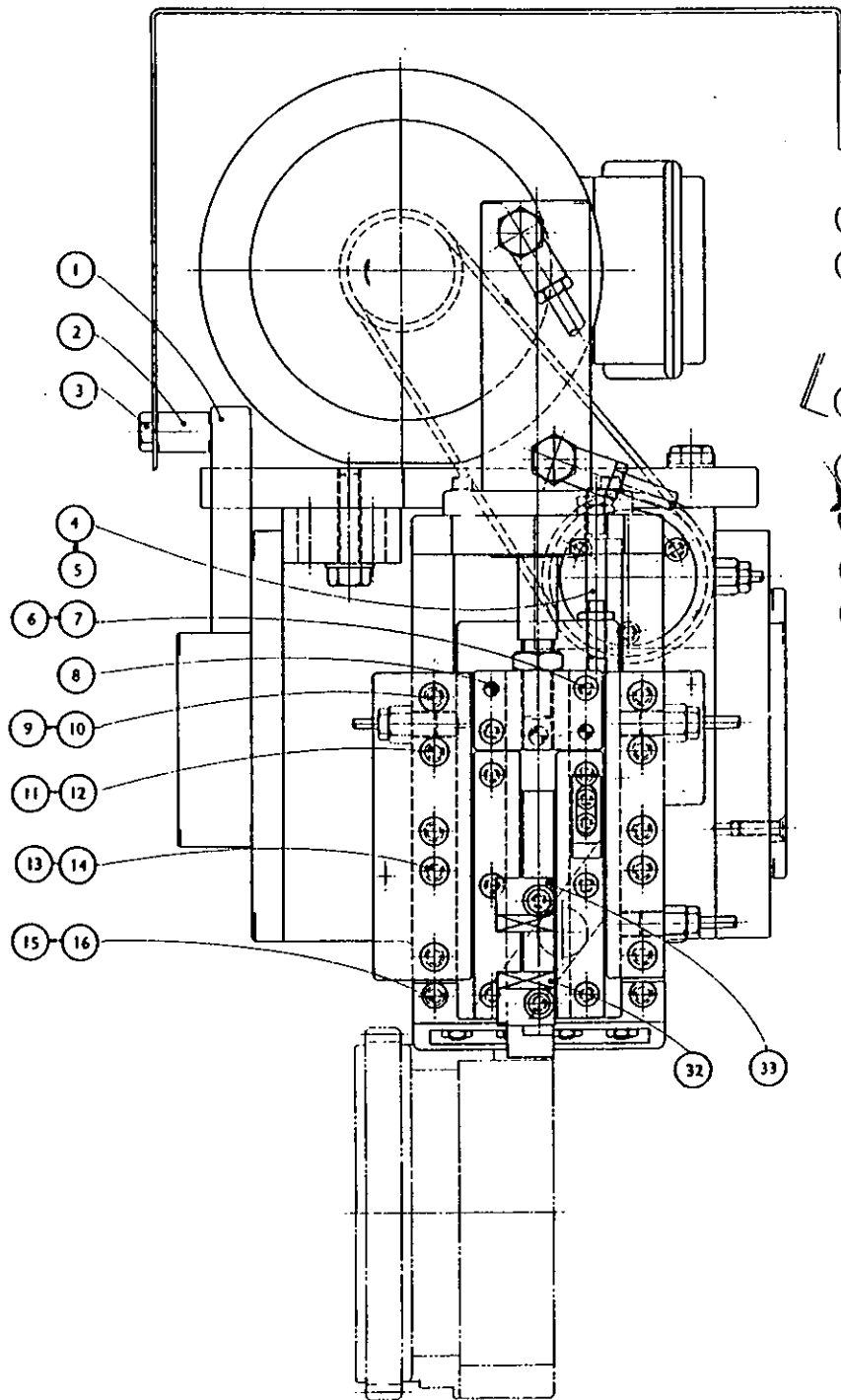

MAXAM AIR CYLINDER 1 1/2" BORE 1" STROKE
 FRONT FLANGE MOUNTED DOUBLE
 ACTING CUSHIONED REF N° 7015 P 99855

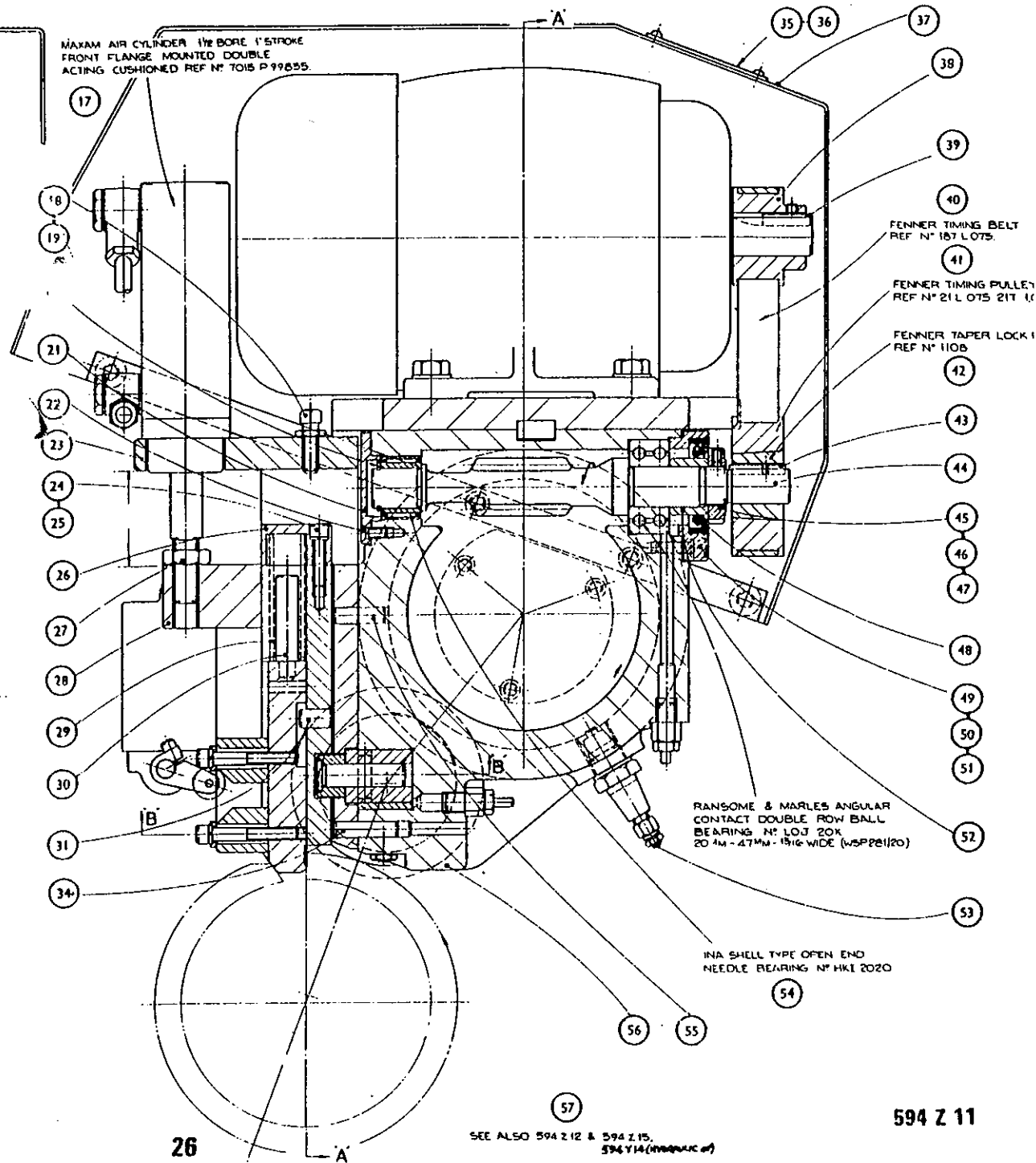

FENNER TIMING BELT
 REF N° 187 L 075

FENNER TIMING PULLEY
 REF N° 21 L 075 21T 1/2"

FENNER TAPER LOCK
 REF N° 110B

RANSOME & MARLES ANGULAR
 CONTACT DOUBLE ROW BALL
 BEARING N° LOJ 20K
 20 MM - 47 MM - 15/16" WIDE (WSP21/20)

INA SHELL TYPE OPEN END
 NEEDLE BEARING N° HK1 2020

SEE ALSO 594 Z 12 & 594 Z 15.
 594 Y 14 (mechanical)

594 Z 12 SLIDING GEAR SPINDLE LOCATION UNIT ASSEMBLY

5 $\frac{1}{2}$ "-6 MACHINE. SECTION 594E

INDEX NO.	PART NO.	TITLE	INDEX NO.	PART NO.	TITLE
1	164/05	Spring Washer, for 5/16" Dia.		121/102BT	Key, Tapped, 5/16" square x 1 $\frac{1}{4}$ " long
2	155/0520	Socket Head Cap Screw, 5/16" B.S.F. x 1 $\frac{1}{2}$ " long		694X.232	Spacer
3	158/0412	Countersunk Head Screw, 1/4" B.S.F. x 1/2" long	39	268/30	Bail Journal, Light Type, 30, 62, 16mm
4	694X.241	Tenon	40	694X.217	Wormwheel, 30 teeth, 33r.p.m.
5	164/04	Spring Washer, for 1/4" dia.	41	694X.233	Spacer
6	165/0412	Socket Head Cap Screw, 1/4" B.S.F. x 1/2" long	42	141/4	Taper Dowel, 11/32" dia. x 1 $\frac{1}{4}$ " long
7	694X.237	Slide Base	43	694X.215	Clutch ESD10
8	154/04	Spring Washer, for 1/4" dia.	44	126/0816	Dowel, 1/4" dia. x 1" long
9	165/0424	Socket Head Cap Screw, 1/4" B.S.F. x 1 $\frac{1}{2}$ " long	45	694X.229	Wear Strip
10	694V.247	Oiling Cap	46	178/0416	Socket Set Screw, Half-Dog, 1/4" B.S.F. x 1" long
11	153/04	Soft Pad, for 1/4" dia.	47	173/04L	Locknut, 1/4" B.S.F.
12	176/0405	Socket Set Screw, 1/4" B.S.F. x 6/16" long	48	126/0614	Dowel, 3/16" dia. x 7/8" long
13	161/30	Slotted Locknut	49	LDJ 25K	Ransome & Marles Angular Contact Double Row Ball Bearing, 26mm x 52mm x 13/16" wide
14	118X.208	Oil Nipple	50	-	Section "AA" - See 594 Z 11
15	418X.168	Oil Bush	51	165/0514	Socket Head Cap Screw, 5/16" B.S.F. x 7/8" long
16	694V.222	Wormwheel Shaft	52	164/05	Spring Washer, for 5/16" B.S.F.
17	-	Copper Tube, 3/16" dia.	53	-	View in Direction of Arrow "C" - See 594 Z 11
18	216/3	Tubing Nut	54	164/05	Spring Washer, for 5/16" dia.
19	221/3	Tubing Sleeve	55	165/0516	Socket Head Cap Screw, 5/16" B.S.F. x 1" long
20	218/2	Enots Mate Adaptor	56	694X.220	Spacer
21	694X.235	Bearing Spacer	57	164/05	Spring Washer, for 5/16" dia.
22	694X.234	Bearing Spacer	58	165/0516	Socket Head Cap Screw, 5/16" B.S.F. x 1" long
23	104/33	Internal Circlip, 62mm	59	694X.243	Block
24	694X.236	Spacer	60	167/0632	Hexagon Head Screw, 3/8" B.S.F. x 2" long
25	694X.225	Clutch Gear, 40 teeth, 33 r.p.m.	61	173/06L	Locknut, 3/8" B.S.F.
26	694X.232	Spacer	62	167/0620	Hexagon Head Screw, 3/8" B.S.F. x 1 $\frac{1}{2}$ " long
27	D80A	Standard Brook totally enclosed motor, Metric Range, foot-mounted, 1/4 h.p., 1500 r.p.m., 380/440 Volts, 3-Phase, 50 Cycles	63	130/06	Washer, for 3/8" dia.
28	167/0624	Hexagon Head Screw, 3/8" B.S.F. x 1 $\frac{1}{2}$ " long	64	167/0616	Hexagon Head Screw, 3/8" B.S.F. x 1" long
29	130/06	Washer for, 3/8" dia.	65	130/06	Washer, for 3/8" dia.
30	166/216	Socket Head Cap Screw, 2 B.A. x 1" long	66	864A2	Square D Limit Switch with arm AA-1 2 pole [1 - clockwise, 2 - anti-clockwise] 5 ⁰ pre-travel, each-way plug in
31	198/6	Lockwasher	67	164/03	Spring Washer, for 3/16" dia.
32	694V.238	Bearing Housing	68	166/220	Socket Head Cap Screw, 2 B.A. x 1 $\frac{1}{4}$ " long
33	164/06	Spring Washer, for 3/8" dia.	69	694X.265	Locator Guide
34	165/0616	Socket Head Cap Screw, 3/8" B.S.F. x 1" long	70	164/04	Spring Washer, for 1/4" dia.
35	158/0412	Countersunk Head Screw, 1/4" B.S.F. x 1/2" long			
36	694X.260	Plate			

List of Parts for
Plate No. 27
(Drawing No. 594 Z 12)

WHEN ORDERING SPARE PARTS ALWAYS QUOTE THE INSPECTION NUMBER OF THE MACHINE

**SPINDLE LOCATION UNIT
ASSEMBLY OF CAM OPERATED STOPPING UNIT
6 1/4" - 6 CHUCKING MACHINE**

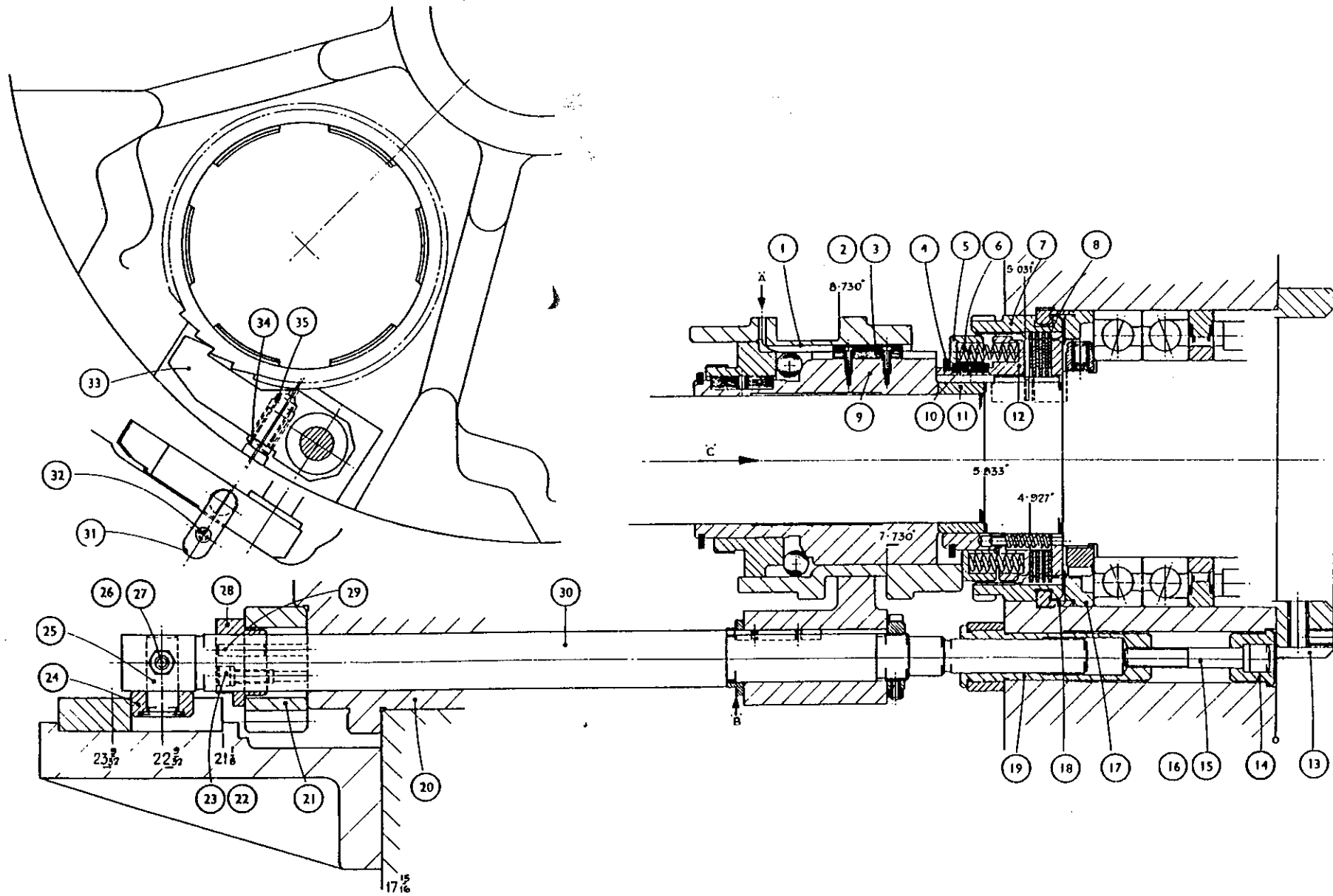

594 Z 11 SLIDING GEAR SPINDLE LOCATION UNIT ASSEMBLY

5 1/4" - 6 MACHINE. SECTION 594E

INDEX NO.	PART NO.	TITLE	INDEX NO.	PART NO.	TITLE
1	694X.221	Support Bar	30	594X.263	Spring Guide
2	694X.220	Spacer	31	126/1210	Dowel 3/4" dia. x 5/8" long
3	167/0624	3/8" B.S.F. Hexagon Head Screw 1 1/2" long	32	694X.268	Trip Block
4	694X.262	Stud	33	694X.269	Trip Block
5	175/06L	5/16" B.S.F. Locknut	34	126/1020	Dowel 5/16" dia. x 1 1/4" long
6	164/04	Spring Washer, for 1/4" Dia.	35	165/404	4 B.A. Round Head Set Screw 1/4" long
7	165/04E	1/4" B.S.F. Socket Cap Screw 2 1/4" long	36	694X.275	Belt Tension Instruction Plate
8	126/081"1	Dowel 1/2" dia. x 1 1/4" long	37	694Y.219A	Location Unit Cover
9	154/05	Spring Washer for 5/16" dia.	38	694X.263	Modification to Fenner Pulley
10	155/0516	5/16" B.S.F. Socket Cap Screw 1" long	39	694X.264	Key
11	164/05	Spring Washer for 5/16" dia.	40	187L.075	Fenner Timing Belt
12	165/0540	5/16" B.S.F. Socket Cap Screw 2 1/2" long	41	21L.075	Fenner Timing Pulley
13	154/05	Spring Washer, for 5/16" dia.	42	1108	Fenner Taper Lock Bush
14	155/0544	5/16" B.S.F. Socket Cap Screw 2 1/4" long	43	121/0618T	Key 3/16" Square x 1 1/4" long
15	154/05	Spring Washer, for 5/16" dia.	44	694X.216	Wormshaft
16	155/0518	5/16" B.S.F. Socket Cap Screw 1" long	45	151/20	Slotted Locknut
17	7015 P 99855	Maxam Air Cylinder	46	179/204	2 B.A. Socket Head Set Screw 3/16" long
18	188/0616	5/16" B.S.F. Square Head Set Screw 1" long	47	163/42	Soft Pad
19	173/05L	5/16" B.S.F. Locknut	48	235/18302	Oil Seal Gaco M15 12
20	103/9	20mm External Circlip	49	694X.244	Seal Housing
21	694X.245A	Bung	50	155/0412	1/4" B.S.F. Socket Cap Screw 3/4" long
22	169/208	2 B.A. Counter Sunk Head Screw 1/2" long	51	154/04	Spring Washer, for 1/4" dia.
23	694Y.249A	Mounting Plate	52	694X.254	Spacer
24	155/0416	1/4" B.S.F. Socket Cap Screw 1" long	53	9217X.165	Clutch Brush
25	154/04	Spring Washer, for 1/4" dia.	54	HK 1. 2020	Ina Needle Bearing
26	694X.261	Spring Block	55	126/1016	Dowel 5/16" dia. x 1" long
27	173/08L	1/2" B.S.F. Locknut	56	694Z.250	Location Unit Body
28	694X.262A	Pusher Block	57		See also 594 Z 12 and 594 Z 16
29	694X.242	Compression Spring			694 Y 14 (Hydraulic Operated)

List of Parts for
Plate No. 25
(Drawing No. 594 Z 11)

WHEN ORDERING SPARE PARTS ALWAYS QUOTE THE INSPECTION NUMBER OF THE MACHINE

ARRANGEMENT OF CLUTCH OPERATING CAMS

6 1/8"-6, 6 1/8"-6D CHUCKING MACHINES

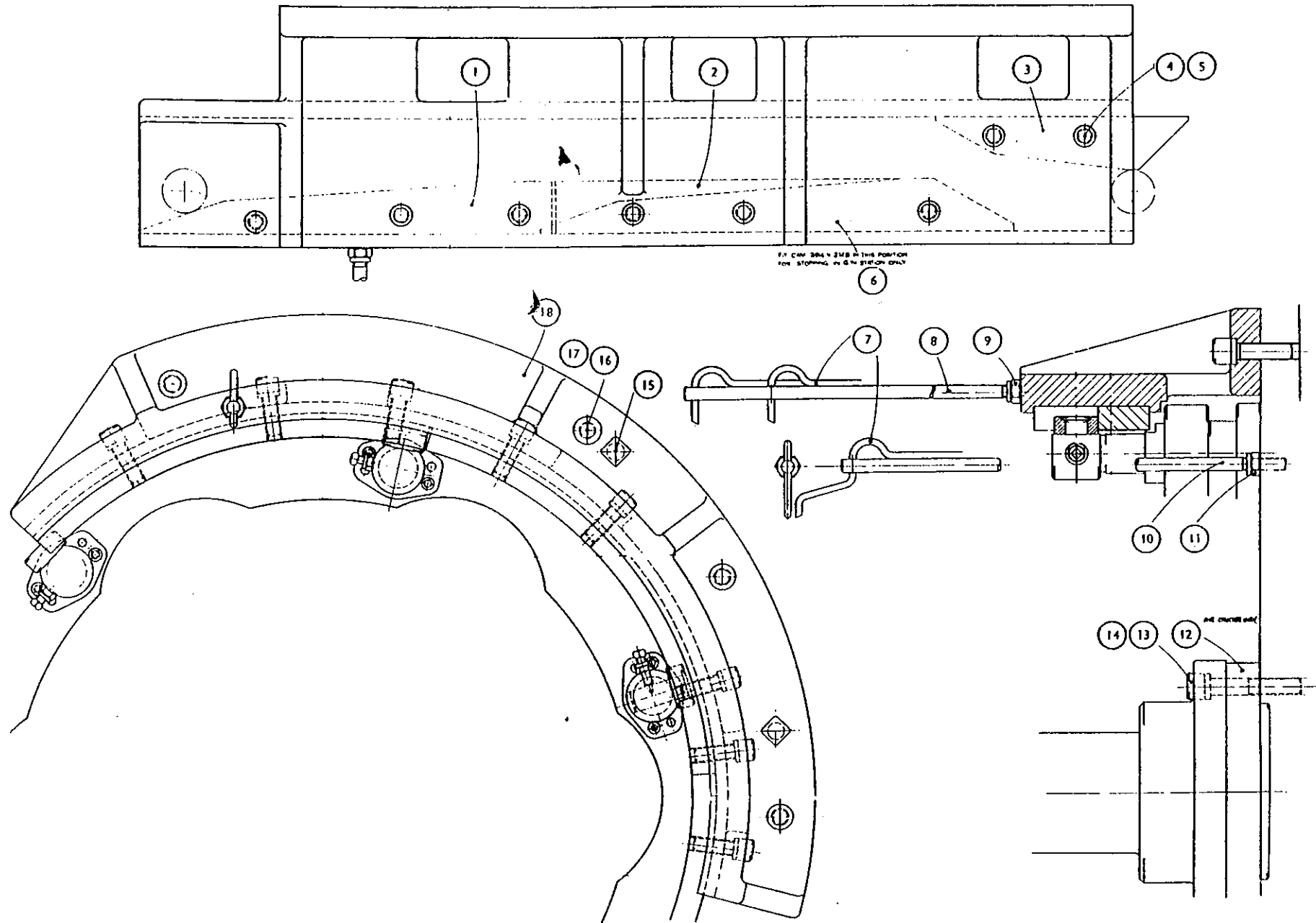

394 Y 8A SPECIAL SPINDLE ASSEMBLY FOR SPINDLE LOCATION

6 $\frac{1}{2}$ "-6 CHUCKING MACHINE. SECTION 394

INDEX NO.	PART NO.	TITLE
1	394Y.206A	Clutch Bobbin
2	169/0408	4BA Counter Sunk Screw x $\frac{1}{2}$ " long
3	303X.205	Clutch Centre Key
4	355/362	$3\frac{3}{4}$ " Dia. Retaining Ring
5	394X.217	Brake Spring Housing
6	202X.199	Spring
7	394V.201C	Brake Housing
8	394X.204	Clutch Plate
9	394V.219	Clutch Inner Member
10	122/0812T	$\frac{1}{4}$ " x $3/16$ " Key $\frac{1}{4}$ " long
11	394X.218	Spacer
12	394V.226	Brake Clutch Housing
13	394X.215	Binding Cap
14	394X.211	Bush
15	155/0640	$\frac{3}{8}$ " BSF Socket Head Cap Screw 2 $\frac{1}{2}$ " long
16	154/06	$\frac{3}{8}$ " Spring Washer
17	394X.203A	End Spacer
18	394X.202	Retaining Ring
19	394X.210	Glut Rod Bearing
20	394Y.200A	Spindle Drum
21	394X.186A	Index Gear
22	154/04	$\frac{1}{4}$ " Spring Washer
23	155/0412	$\frac{1}{4}$ " BSF Socket Head Cap Screw $\frac{1}{4}$ " long
24	150X.130	Roller
25	394X.222	Roller Pin
26	203/04	$\frac{1}{2}$ " BSF Hex. Locknut
27	182/0414	$\frac{1}{4}$ " BSF Socket Set Screw $\frac{3}{8}$ " long Taper Point
28	394X.185A	Glut Rod Bearing
29	126/1616	$\frac{1}{4}$ " Dia. Taper Pin 1" long
30	394V.212A	Glut Operating Shaft
31	394X.209A	Pressure Key
32	155/0408	$\frac{1}{4}$ " BSF Socket Head Cap Screw 1 $\frac{1}{2}$ " long
33	394X.205C	Latch
34	394X.208	Plunger
35	394X.207	Compression Spring

List of Parts for
Plate No. 25
(Drawing No.394Y8A)

WHEN ORDERING SPARE PARTS ALWAYS QUOTE THE INSPECTION NUMBER OF THE MACHINE

SPINDLE LOCATION UNIT. PNEUMATIC MACHINES
SPINDLE GEARS. STATION 6
6 1/4"-6 CHUCKING MACHINE

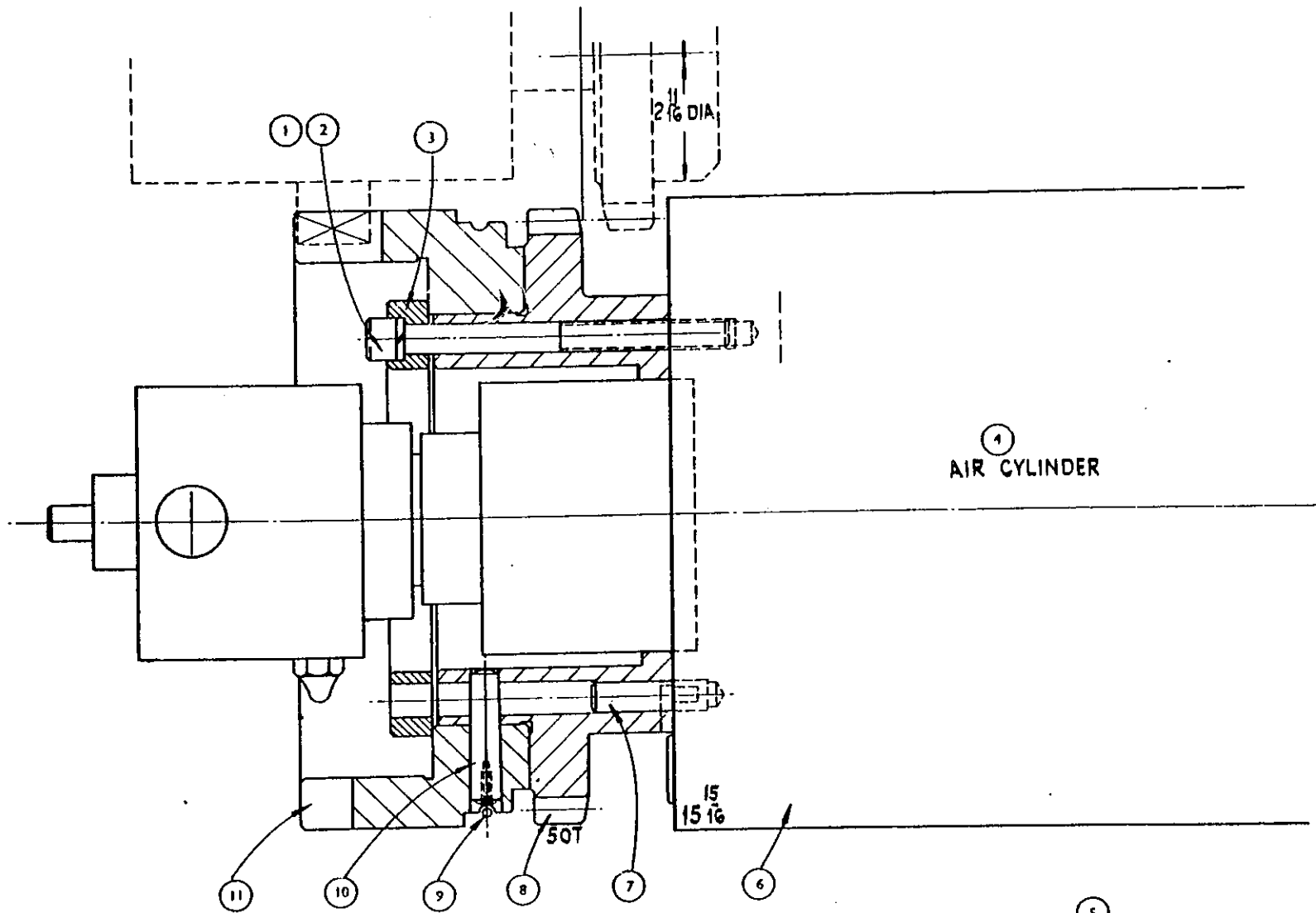

NOTE! CENTRE STEM MODIFIED TO 394V249

394 Z 3D ARRANGEMENT OF CLUTCH OPERATING CAMS

6 $\frac{1}{4}$ " - 6 CHUCKING MACHINES. SECTION 394

INDEX NO.	PART NO.	TITLE
1	394V.181C	Brake Cam
2	394V.216A	Guard Cam
3	394X.213B	Start Cam
4	155/0720	7/16" BSF Socket Head Cap Screw 1 $\frac{1}{2}$ " long
5	154/07	7/16" Spring Washer
6	-	Fit Cam 394V214C in this position for stopping in 6th station only.
7	225/3035	3/16" Copper Tube
8	394X.195	Oil Pipe Support
9	203/06	3/8" BSF Self Locking Hex. Nut
10	394X.195	Oil Pipe Support
11	203/06	3/8" BSF Self Locking Hex. Nut
12	394X.178	Stem Spacer (Air Chucker only)
13	155/0844	1/2" BSF Socket Head Cap Screw 2 $\frac{1}{2}$ " long
14	154/08	1/2" Spring Washer
15	139/17	1/2" Taper Dowel 2 $\frac{1}{2}$ " long
16	155/0832	1/2" BSF Socket Head Cap Screw 2" long
17	154/08	1/2" Spring Washer
18	394Z.180C	Cam Bracket

List of Parts for
Plate No.24
(Drawing No.394Z3D)

WHEN ORDERING SPARE PARTS ALWAYS QUOTE THE INSPECTION NUMBER OF THE MACHINE

SPINDLE LOCATION UNIT. SPINDLE GEARS STATIONS 5 & 6
6 1/4"-6H CHUCKING MACHINES

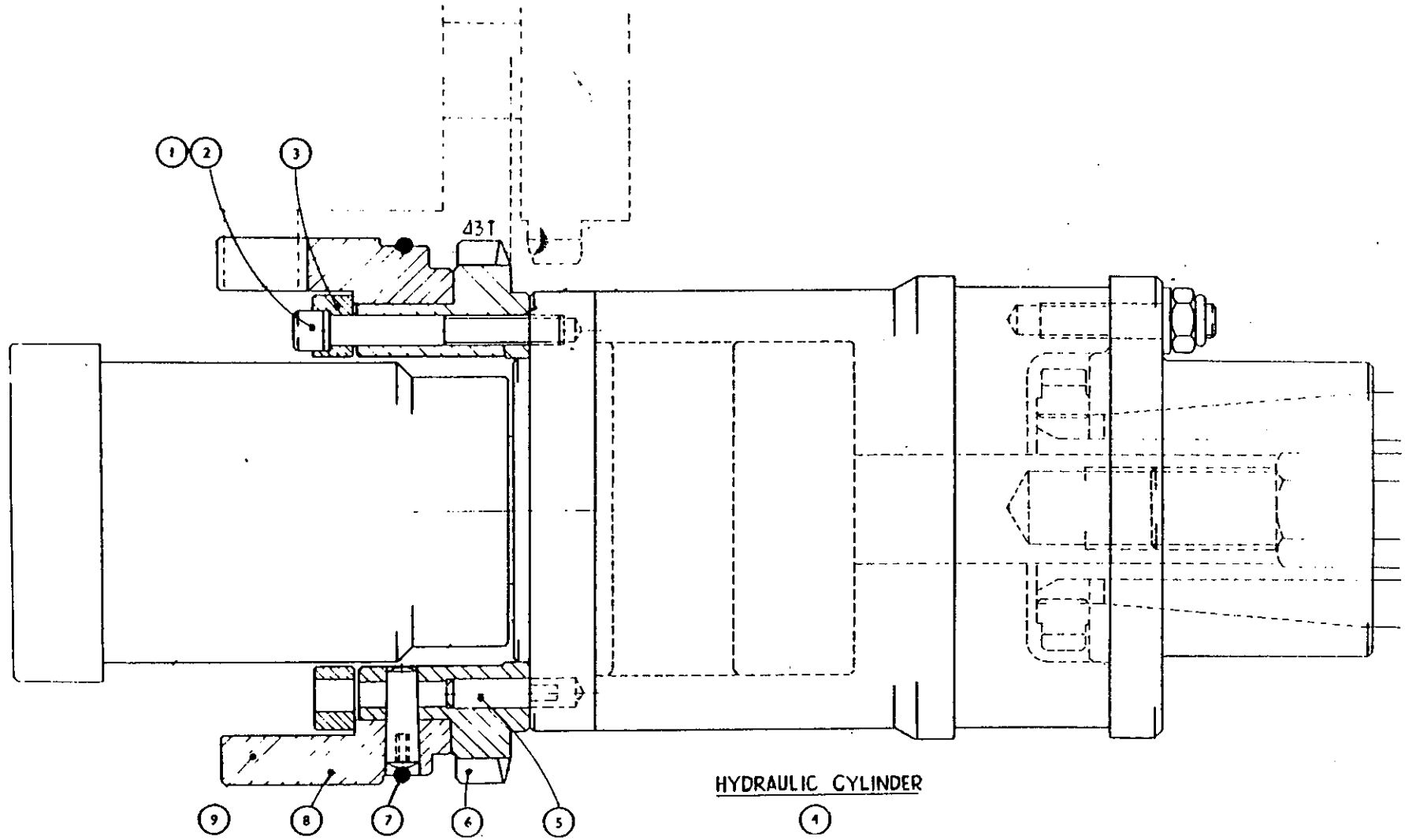

394 V 10 SLIDING GEAR LOCATION SPINDLE ASSEMBLY

6 $\frac{1}{2}$ "-6 AIR CHUCKER. SECTION 394

INDEX NO.	PART NO.	TITLE
1	154/05	5/16" Spring Washer
2	155/0556	5/16" BSF Socket Head Cap Screw 3 $\frac{1}{2}$ " long
3	394X.232	Clamp Plate
4	-	Air Cylinder
5	-	Note: Centre Stem Modified to 394V249
6	394X.248	Air Cylinder TC 143
7	594X.153	Dowel for Gear
8	394V.253	Location Gear
9	-	Soft Iron Wire
10	141/4	11/32" Taper Pin x 1 $\frac{1}{4}$ " long
11	394V.254	One Way Location Ring

List of Parts for
Plate No. 23
(Drawing No.394V10)

WHEN ORDERING SPARE PARTS ALWAYS QUOTE THE INSPECTION NUMBER OF THE MACHINE

CHASING ATTACHMENT. EXTRA PARTS FOR SECTION 392 MK.I, 4TH AND 5TH STATIONS
6 3/4" - 6 CHUCKING MACHINE

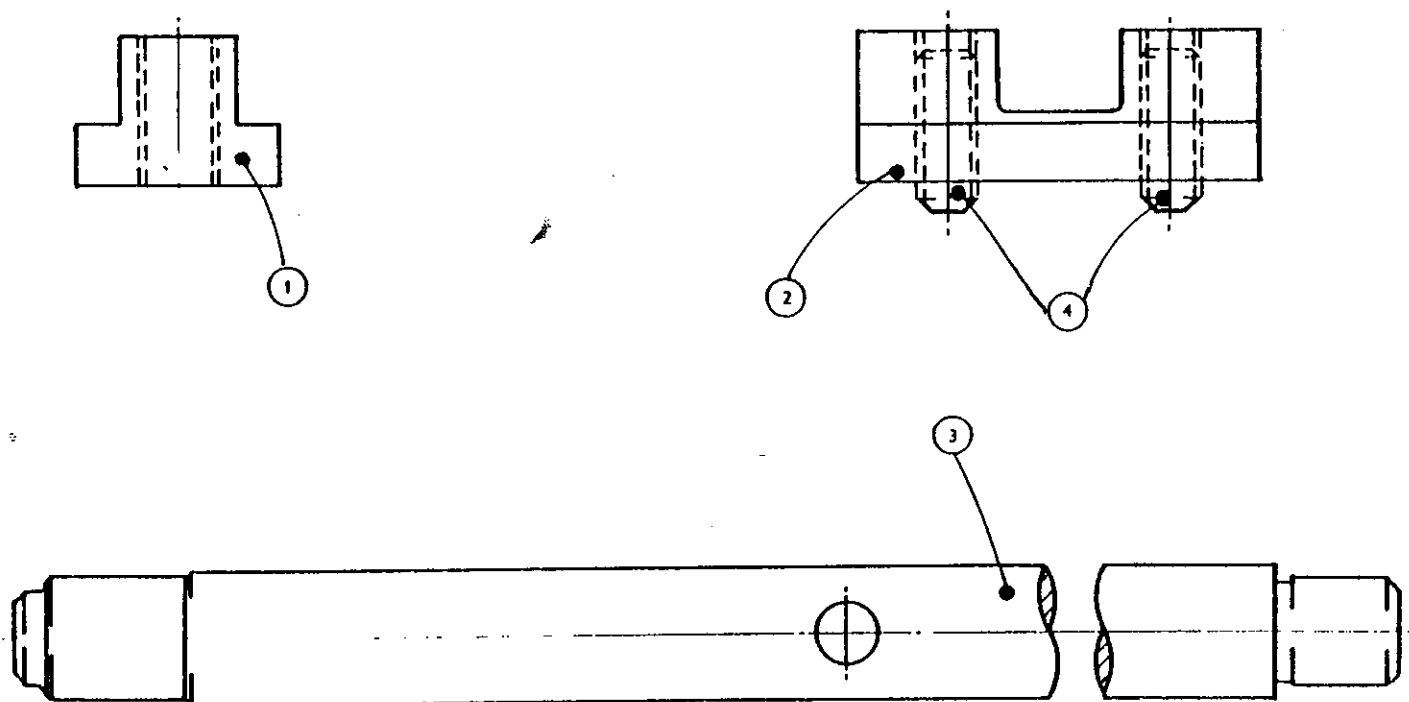

394 V 9 SLIDING GEAR SPINDLE LOCATION. SPINDLE ASSEMBLY HYDRAULIC CHUCKER
5½"-6 MACHINE. SECTION 594E

INDEX NO.	PART NO.	TITLE
1	154/05	Spring Washer for 5/16" L. dia.
2	155/0540	5/16" B.S.F. Socket Cap Screw 2½" long
3	394X.232	Clamp Plate
4		Hydraulic Cylinder
5	594X.153	Dowel for Gear
6	394V.227B	Locating Gear
7		Soft Iron Wire
8	141/2	Taper Pin 11/32" Dia. x 1" long
9	394X.228	Locating Ring (1 Way)

6

List of Parts for
Plate No. 22
(Drawing No. 394 V 9)

WHEN ORDERING SPARE PARTS ALWAYS QUOTE THE INSPECTION NUMBER OF THE MACHINE

EXTRA PARTS USING SECTION 192 MK.III CHASING ATTACHMENT IN STATION 4

2 1/4" - 6 BAR MACHINE, 6 1/4" - 6 CHUCKING MACHINE

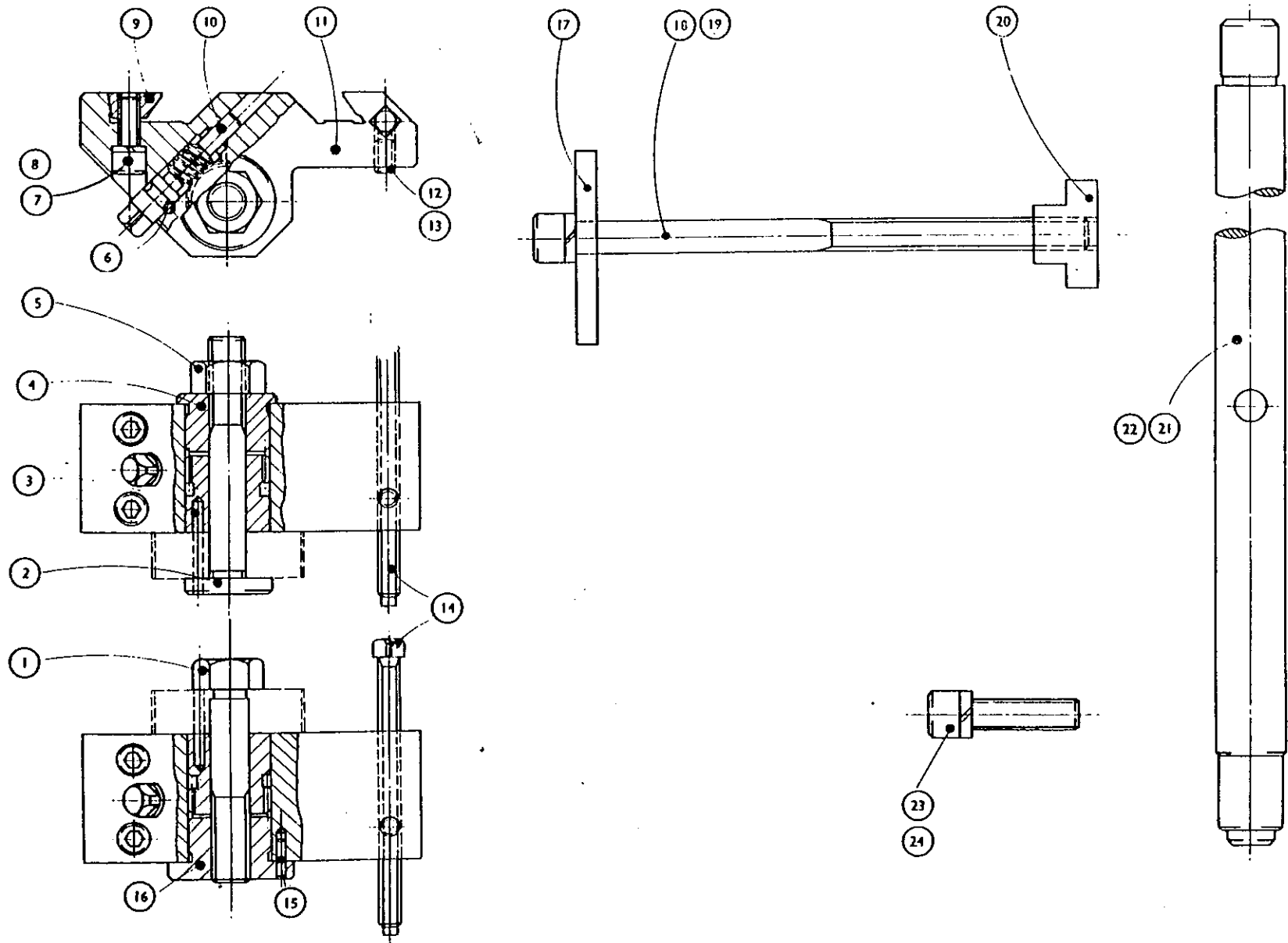

392 X 9 EXTRA PARTS USING SECTION 392 MARK I 4TH AND 5TH STATION
6 1/4"-6, 6 1/4"-6D CHUCKING MACHINES

INDEX NO.	PART NO.	TITLE
1	392X.183	Tee Nut
2	392X.132	Pivot Block
3	392X.190	Drive Shaft
4	176/0616	3/8" BSF Socket Set Screw 1" long

List of Parts for
Plate No.21
(Drawing No.392X9)

WHEN ORDERING SPARE PARTS ALWAYS QUOTE THE INSPECTION NUMBER OF THE MACHINE

CHASING ATTACHMENT
EXTRA PARTS USING SECTION 392 MK.I, STATIONS 4 AND 5
2 1/4" - 6 BAR MACHINE

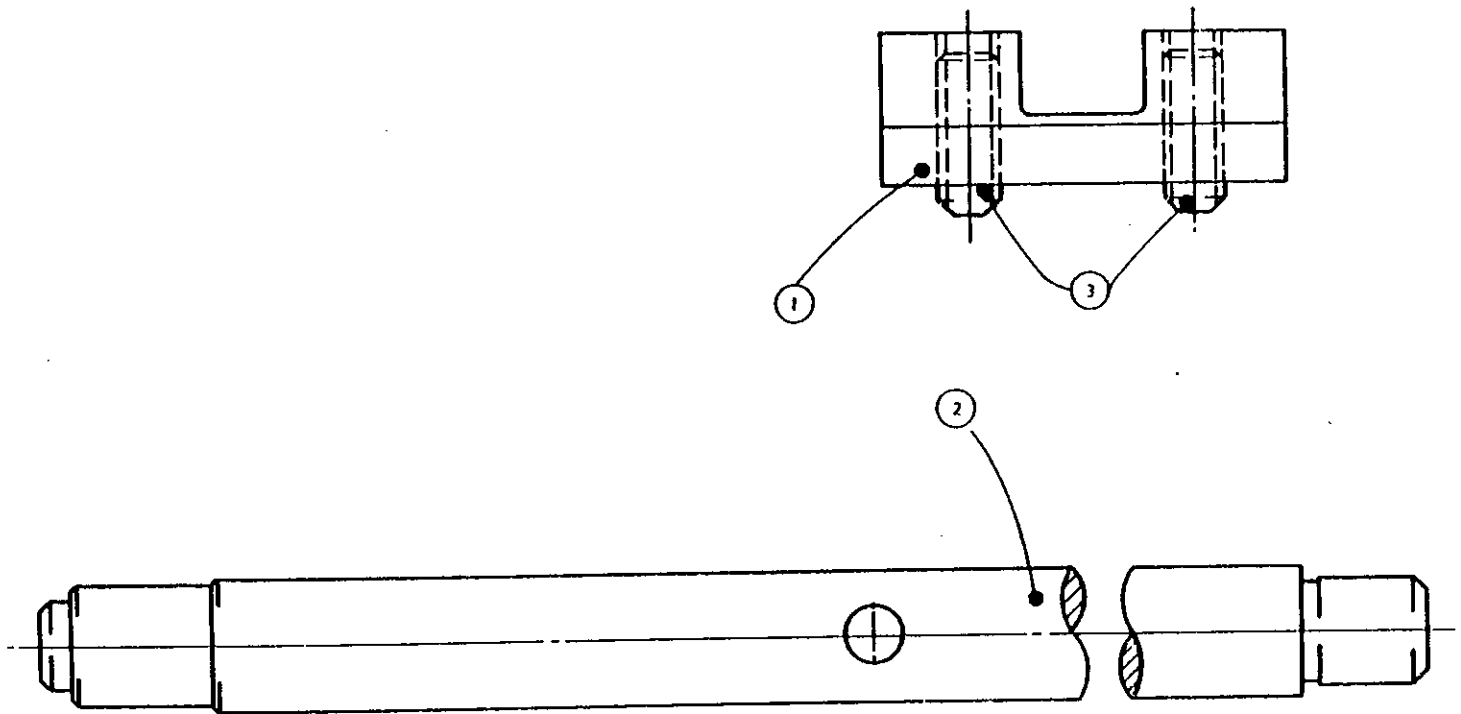

392 V 8 EXTRA PARTS USING SECTION 192 MARK III CHASING ATTACHMENT IN STATION 4

2¼"- 6, 2¼"- 6D BAR MACHINES

6⅝"- 6, 6⅝"- 6D CHUCKING MACHINES

INDEX NO.	PART NO.	TITLE
1	192X.140	Clamp Bolt
2	192X.134	Clamp Bolt
3	192X.135A	Adjusting Gear
4	192X.138A	Clamp Bush
5	173/07H	7/16" BSF Hexagon Nut
6	124/0414	1/8" Parallel Pin 7/8" long
7	156/0410	1/4" BSF Socket Head Cap Screw 5/8" long
8	154/04	1/4" Spring Washer
9	192X.137	Clamp
10	192X.136A	Adjusting Worm
11	392X.516 A	Chaser Bracket
12	153/04	1/4" Brass Pad
13	176/0406	1/4" BSF Socket Set Screw 3/8" long
14	188/0452	1/4" BSF Square Head Set Screw 3/4" long
15	124/0406	1/8" Parallel Pin 3/8" long
16	192X.139A	Clamp Nut
17	392X.512	Cover Plate
18	165/0696	3/8" BSF Socket Head Cap Screw 6"
19	154/06 -	3/8" Spring Washer
20	392X.513	Tee Nut
21	392X.169	Drive Shaft (2¼"- 6 machine only)
22	392X.190	Drive Shaft (6⅝"- 6 machine only)
23	165/0620	3/8" BSF Socket Head Cap Screw 1¼" long
24	154/06	3/8" Spring Washer

List of Parts for
Plate No.20
(Drawing No.392V8)

WHEN ORDERING SPARE PARTS ALWAYS QUOTE THE INSPECTION NUMBER OF THE MACHINE

CHASING ATTACHMENT EXTRA PARTS FOR SECTION 192 MK. I,II,III IN 5TH STATION

2¼"-6, 2¼"-6D, 2"-6 AND 2"-6D BAR MACHINES

6¾"-6, 6¾"-6D CHUCKING MACHINES.

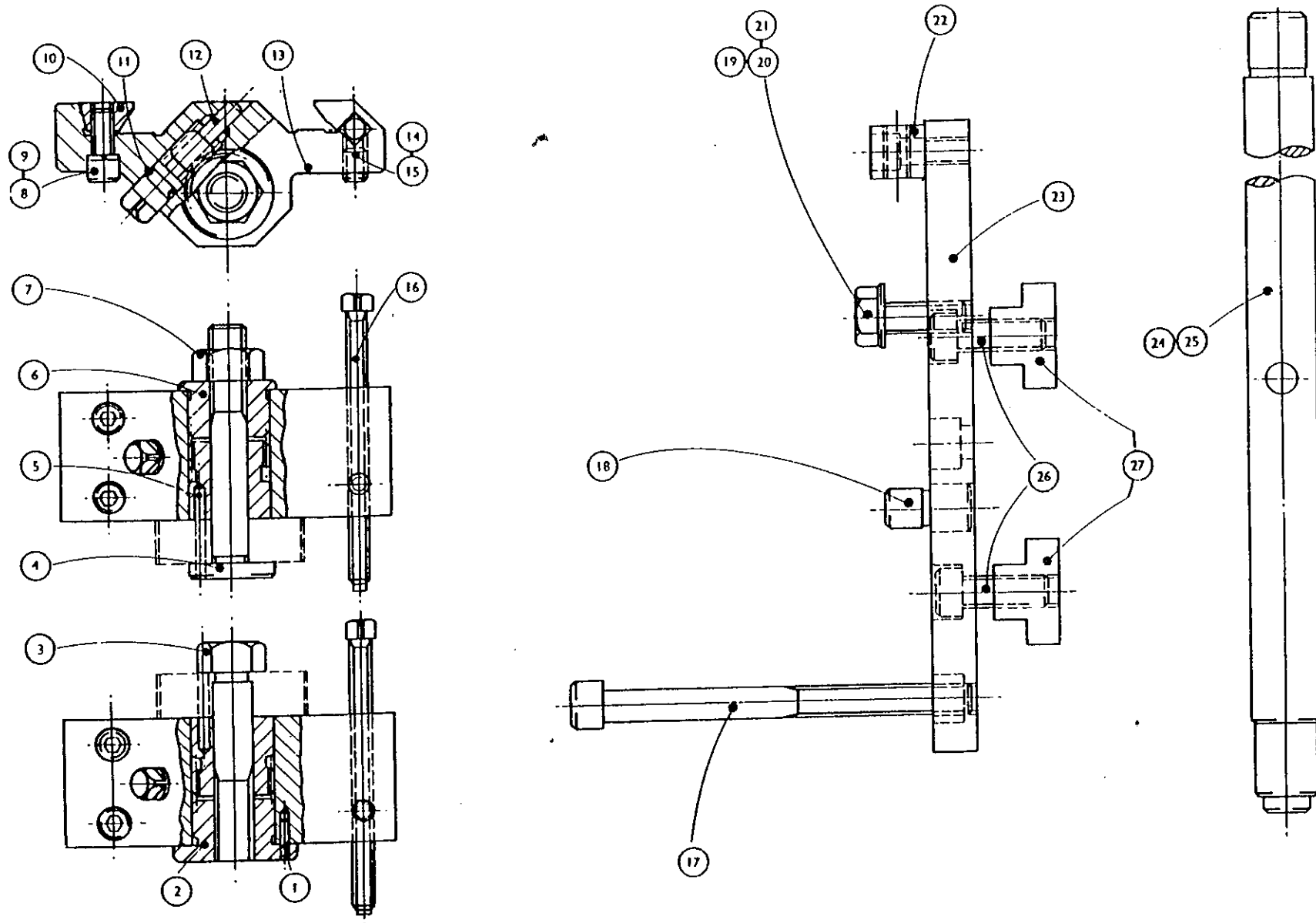

392 X 10 EXTRA PARTS USING SECTION 392 MARK I 4TH AND 5TH STATION
2 1/4"-6, 2 1/4"- 6D BAR MACHINES

3921A1103

INDEX NO.	PART NO.	TITLE
1	392X.132	Pivot Block
2	392X.186	Drive Shaft
3	176/0616	3/4" BSF Socket Set Screw 1" long

List of Parts for
Plate No.19
(Drawing No.392X10)

WHEN ORDERING SPARE PARTS ALWAYS QUOTE THE INSPECTION NUMBER OF THE MACHINE

CHASING ATTACHMENT DRIVE MK.III 5TH STATION 392A, 4TH STATION 392D

2 1/4" - 6 BAR, 6 3/4" - 6 CHUCKING MACHINES

ST 5
392x186

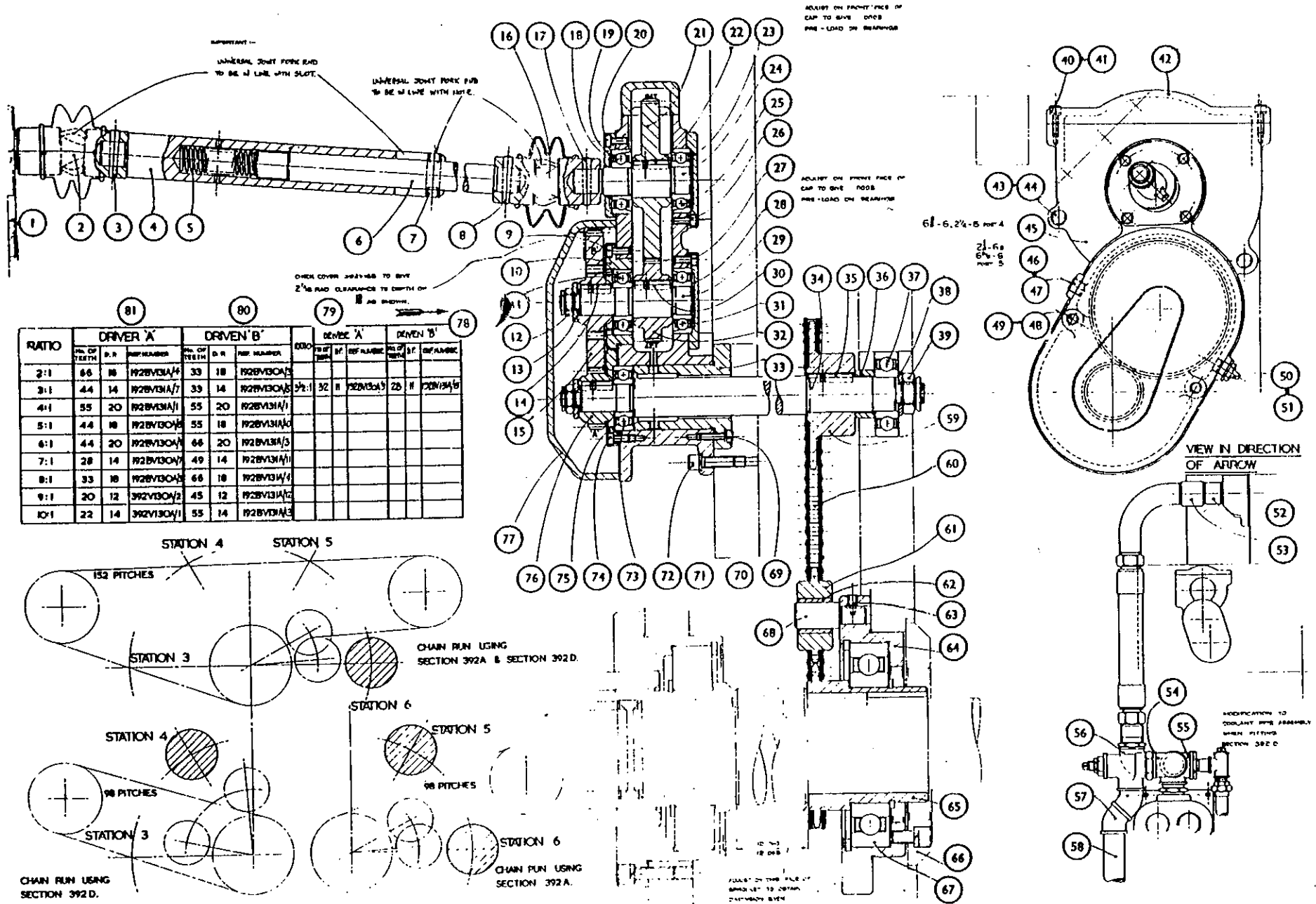

RATIO	DRIVER 'A'			DRIVEN 'B'			D.D.	DRIVEN 'A'		DRIVEN 'B'				
	NO. OF TEETH	D.P.	REF. NUMBER	NO. OF TEETH	D.P.	REF. NUMBER		NO. OF TEETH	D.P.	REF. NUMBER	NO. OF TEETH	D.P.	REF. NUMBER	
2:1	66	18	192BV130A/4	33	18	192BV130A/1								
3:1	44	14	192BV131A/7	33	14	192BV130A/1	32:1	32	11	192BV130A/3	28:1	28	11	192BV134A/5
4:1	55	20	192BV131A/1	55	20	192BV131A/1								
5:1	44	18	192BV130A/1	55	18	192BV131A/1								
6:1	44	20	192BV130A/1	66	20	192BV131A/3								
7:1	28	14	192BV130A/1	49	14	192BV131A/1								
8:1	33	18	192BV130A/1	66	18	192BV131A/1								
9:1	20	12	192BV130A/2	45	12	192BV131A/1								
10:1	22	14	192BV130A/1	55	14	192BV131A/3								

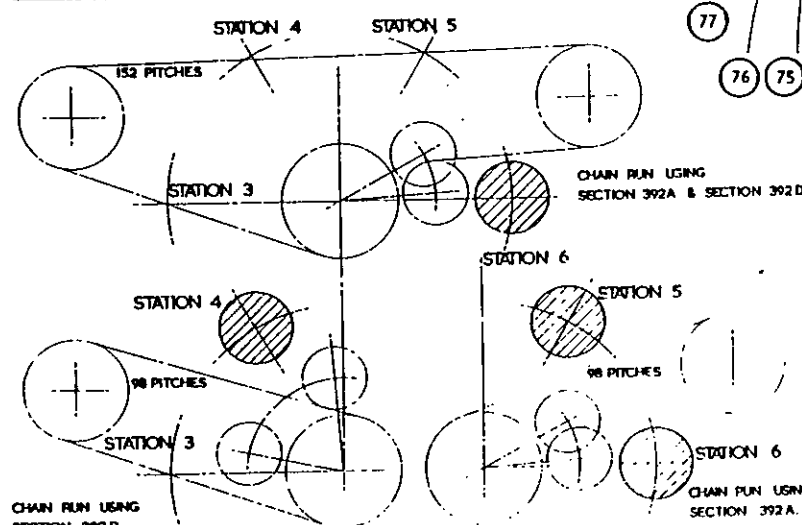

392 V 7 EXTRA PARTS USING SECTION 192, MARK I, II, III CHASING ATTACHMENT 5TH STATION
2 1/4"-6 BAR AND 6 3/8"-6 CHUCKING MACHINES. SECTION 392B MK II

INDEX NO.	PART NO.	TITLE
1	124/0406	1/8" Parallel Pin 3/4" long
2	192X.139A	Clamp Nut
3	192X.140	Clamp Bolt
4	192X.134	Clamp Bolt
5	192X.135A	Adjusting Gear
6	192X.138A	Clamp Bush
7	173/07H	7/16" BSF Hex. Nut, Hard
8	155/0410	1/4" BSF Socket Head Cap Screw 5/8" long
9	154/04	1/4" Spring Washer
10	192X.137	Clamp
11	124/0414	1/8" Parallel Pin 7/8" long
12	192X.136A	Adjusting Worm
13	192X.133A	Chaser Bracket
14	153/04	Brass Pad
15	176/0406	1/4" BSF Socket Set Screw Cup Point, 3/4" long
16	188/0452	1/4" BSF Square Head Set Screw 3/4" long
17	155/0668	3/8" BSF Socket Head Cap Screw 4 1/2" long
18	392X.514	Locator
19	155/0616	3/8" BSF Socket Head Cap Screw 1" long
20	187/0616H	3/8" BSF Hexagon Head Set Screw, Hardened, 1" long
21	130/06	3/8" Flat Washer
22	392X.180	Adjustment Strip
23	392V.175	Base Plate
24	392X.190	Drive Shaft 6 3/8"-6 machine only
25	392X.169	Drive Shaft 2 1/4"-6 machine only
26	392X.522	Screw
27	392X.513	Toe Nut

List of Parts for
 Plate No.18
 (Drawing No.392V7)

WHEN ORDERING SPARE PARTS ALWAYS QUOTE THE INSPECTION NUMBER OF THE MACHINE

392 Z 1A CHASING ATTACHMENT DRIVE 2 1/4"-6 & 6 3/4"-6 STATION 5 SECTION 392A MK.III
 2 1/4"-6 & 6 3/4"-6 STATION 4 SECTION 392D MK.III

2 1/4"-6, 6 3/4"-6 MACHINES. SECTIONS 392A, 392D



INDEX NO.	PART NO.	DESCRIPTION
73	258/20	Light Metric Ball Journal, 20mm
74	156/20	Socket Head Cap Screw, 2 B.A. x 1/2" long
75	192AX	Clamp Ring
76	-	See Table
77	392V.16	Gear Cover
78	-	Driven "B"
		No. of Teeth D.P. Reference No.
79	-	Driver "A"
		Ratio No. of Teeth D.P. Reference No.
80	-	Driven "B"
		No. of Teeth D.P. Reference No.
81	-	Driver "A"
		Ratio No. of Teeth D.P. Reference No.

List of Parts for
 Plate No.17
 (Drawing No. 392 Z 1A)

WHEN ORDERING SPARE PARTS ALWAYS QUOTE THE INSPECTION NUMBER OF THE MACHINE

392 Z 1A CHASING ATTACHMENT DRIVE 2 1/4"-6 & 6 3/8"-
2 1/4"-6 & 6 3/8"-6

5 SECTION 392A MK.III
4 SECTION 392D MK.III

2 1/4"-6, 6 3/8"-6 MACHINES. SECTIONS 392A, 392D

INDEX NO.	PART NO.	TITLE	INDEX NO.	PART NO.	TITLE
1	-	See Section 392 MK.I or 192 MK.III	37	267/25	Medium Metric Journal, 25 mm
2	-	Mollart Universal Ball Joint No. 3 with Cover	38	130/10	Flat Washer, for 3/4" dia.
3	125/1622	Taper Pin, 1/4" dia. x 1 1/4" long	39	203/10L	Selflocking Nut, 3/8" B.S.F.
4	192AX.133	Drive Sleeve	40	156/210	Socket Head Cap Screw, 2 B.A. x 3/8" long
5	192AX.132	Coupling Shaft Spring	41	154/03	Spring Washer, for 3/16" dia.
6	-	See Sections 392B MK.II, 392C MK.II, 392E MK.II, 392F MK.II	42	192AX.102	Top Cover
7	192AX.120	Drive Pin	43	154/05	Spring Washer, for 5/16" dia.
8	125/1622	Taper Pin, 1/4" dia. x 1 1/4" long	44	155/054B	Socket Head Cap Screw, 5/16" B.S.F. x 3" long
9	156/208	Socket Head Cap Screw, 2 B.A. x 1/2" long	45	392Y.156A	Drive Box
10	192AX.108	Bearing Housing	46	392Y.156A	Drive Box
11	263/20	Light Metric Angular Contact, 20 mm	47	194/1	Socket Pipe Plug, 1/4" B.S.F.
12	203/07L	Selflocking Nut, 7/16" B.S.F.	48	156/228	Socket Head Cap Screw, 2 B.A. x 1 1/4" long
13	192AX.114	Washer	49	154/03	Spring Washer, for 3/16" dia.
14	121/0814T	Key, Tapped, 1/2" x 1/4" x 7/8" long	60	212/18	Lubrication Nipple, 1/4" B.S.P.
15	-	See Table	61	210/2525	Yellow Indicator Washer, for 1/4" B.S.P.
16	-	Mollart Universal Ball Joint No. 3 with Cover	62	-	Pipe, 2 B.S.P. x 3/8" long
17	125/1622	Taper Pin, 1/4" dia. x 1 1/4" long	63	-	Socket, 2 B.S.P.
18	263/20	Light Metric Angular Contact, 20 mm	64	-	Elbow, 90°, Male and Female
19	192AX.105	End Cap	65	-	Side Outlet Tee, 2 B.S.P.
20	156/208	Socket Head Cap Screw, 2 B.A. x 1/2" long	66	-	Elbow, 90°, Male and Female
21	192AX.109	Driven Gear	67	-	Elbow, 45°, Male and Female
22	121/0816T	Key, Tapped, 1/2" square x 1" long	68	-	Pipe, 2 B.S.P. x 24" long
23	192AX.103	End Cover	69	392X.160	Driven Sprocket
24	192AX.111	Final Shaft	60	-	Chain, B.S. No.3 x 98 Pitches long
25	263/20	Light Metric Angular Contact, 20 mm	61	392X.159	Jockey Sprocket
26	156/208	Socket Head Cap Screw, 2 B.A. x 1/2" long	62	236/121616	Oil Retaining Bush
27	168/208	Socket Head Cap Screw, 2 B.A. x 1/2" long	63	-	See Section 317
28	192AX.103	End Cover	64	-	See Section 317
29	192AX.112	Intermediate Shaft	65	-	See Section 317
30	121/0816T	Key, Tapped, 1/2" square x 1" long	66	-	See Section 317
31	263/20	Light Metric Angular Contact, 20 mm	67	-	For 4-Spindle Machines see 392 Z 1
32	192AX.110	Driving Gear	68	-	See Section 317
33	392X.167	Location Bush	69	156/212	Socket Head Cap Screw, 2 B.A. x 1/2" long
34	392X.165	Drive Shaft	70	154/03	Spring Washer, for 3/16" dia.
35	121/0820T	Key, Tapped, 1/2" square x 1 1/4" long	71	154/05	Spring Washer, for 5/16" dia.
36	392X.166	Spacer	72	155/0516	Socket Head Cap Screw, 5/16" B.S.F. x 1" long

WHEN ORDERING SPARE PARTS ALWAYS QUOTE THE INSPECTION NUMBER OF THE MACHINE

List of Parts for
Plate No. 17
(Drawing No. 392 Z 1A)

392 Z 4 CHASING ATTACHMENT

Section 392 MK. I

2 1/4" - 6, 6 1/4" - 6 MACHINES

INDEX NO.	PART NO.	TITLE	INDEX NO.	PART NO.	TITLE
57	392X104	End Cap	85	124/0414	Parallel Dowel, Silver Steel, 1/8" dia. x 7/8" long
58	155/0412	Socket Head Cap Screw, 1/4" B.S.F. x 3/4" long	86	192X138A	Adjusting Worm
59	154/04	Spring Washer, 1/4" dia.	87	392X133A	Chaser Bracket
60	212/04	Autolub Nipple, Straight, 1/4" B.S.F.	88	188/0448	Square Head Set Screw, 1/4" B.S.F. x 3" long
61	210/1725	Yellow Indicator Washer	89	153/04	Brass Pad for 1/4" B.S.F.
62	176/0406	Set Screw, Cup Point, 1/4" B.S.F. x 3/8" long	90	176/0406	Set Screw, Cup Point, 1/4" B.S.F. x 3/8" long
63	165/404	Round Head Set Screw, 4 B.A. x 1/4" long	91	192X124	Stop
64	192X146	Lubrication Plate	92	156/408	Hexagon Socket Head Cap Screw, 4 B.A. x 1/2" long
65	182/0412	Set Screw, Taper Point, 1/4" B.S.F. x 3/4" long	93	154/4	Spring Washer, 1/4" dia.
66	173/04L	Hexagon Locknut, 1/4" B.S.F.	94	192X135A	Adjusting Gear
67	188/0448	Square Head Set Screw, 1/4" B.S.F. x 3" long	95	192X134	Clamp Bolt
68	192X105A	Oil Cover	96	-	Supplied by Tooling Dept.
69	210/1725	Yellow Indicator Washer	97	192X138A	Clamp Bush
70	212/04	Autolub Nipple, Straight, 1/4" B.S.F.	98	173/07H	Hexagon Nut, Hardened, 7/16" B.S.F.
71	154/08	Spring Washer, 1/2" dia.	99	-	Alternative Position for Chaser
72	155/0896	Socket Head Cap Screw, 1/2" B.S.F. x 6" long	100	326/0306	Tension Pin, 3/32" dia. x 3/8" long
73	392X152	Clamp Plate	101	192X135A	Adjusting Gear
74	392Z101	Main Body	102	192X140	Clamp Bolt
75	212/9004	Autolub Nipple (90°), 1/4" B.S.F.	103	192X139A	Clamp Nut
76	210/1725	Yellow Indicator Washer	104	-	Supplied by Tooling Dept.
77	392X106	Cover Plate	105	192X121	Spring Cap
78	155/0410	Socket Head Cap Screw, 1/4" B.S.F. x 5/8" long	106	392X110	Relief Roller Pin
79	210/1725	Yellow Indicator Washer	107	392X149	Thrust Washer
80	212/4504	Autolub Nipple (45°), 1/4" B.S.F.	108	392X111A	Relief Roller
81	-	Section 'X' 'X'	109	203/05	Selflocking Nut, 5/16" B.S.F.
82	154/04	Spring Washer, 1/4" dia.	110	130/05	Flat Washer for 5/16" dia.
83	155/0410	Socket Head Cap Screw, 1/4" B.S.F. x 5/8" long	111	182/0410	Set Screw, Taper Point, 1/4" B.S.F. x 5/8" long
84	393X137	Clamp	112	392X114	Washer
			113	155/0532	Hexagon Socket Head Cap Screw, 5/16" B.S.F. x 2" long

List of Parts for
Plate No. 16
(Drawing No. 392 Z 4)

WHEN ORDERING SPARE PARTS ALWAYS QUOTE THE INSPECTION NUMBER OF THE MACHINE

CHASING ATTACHMENT, SECTION 192, MK.III

2 1/4"-6, 2 1/4"-6D, 2"-6 AND 2"-6D BAR MACHINES. 6 3/4"-6, 6 3/4"-6D CHUCKING MACHINES

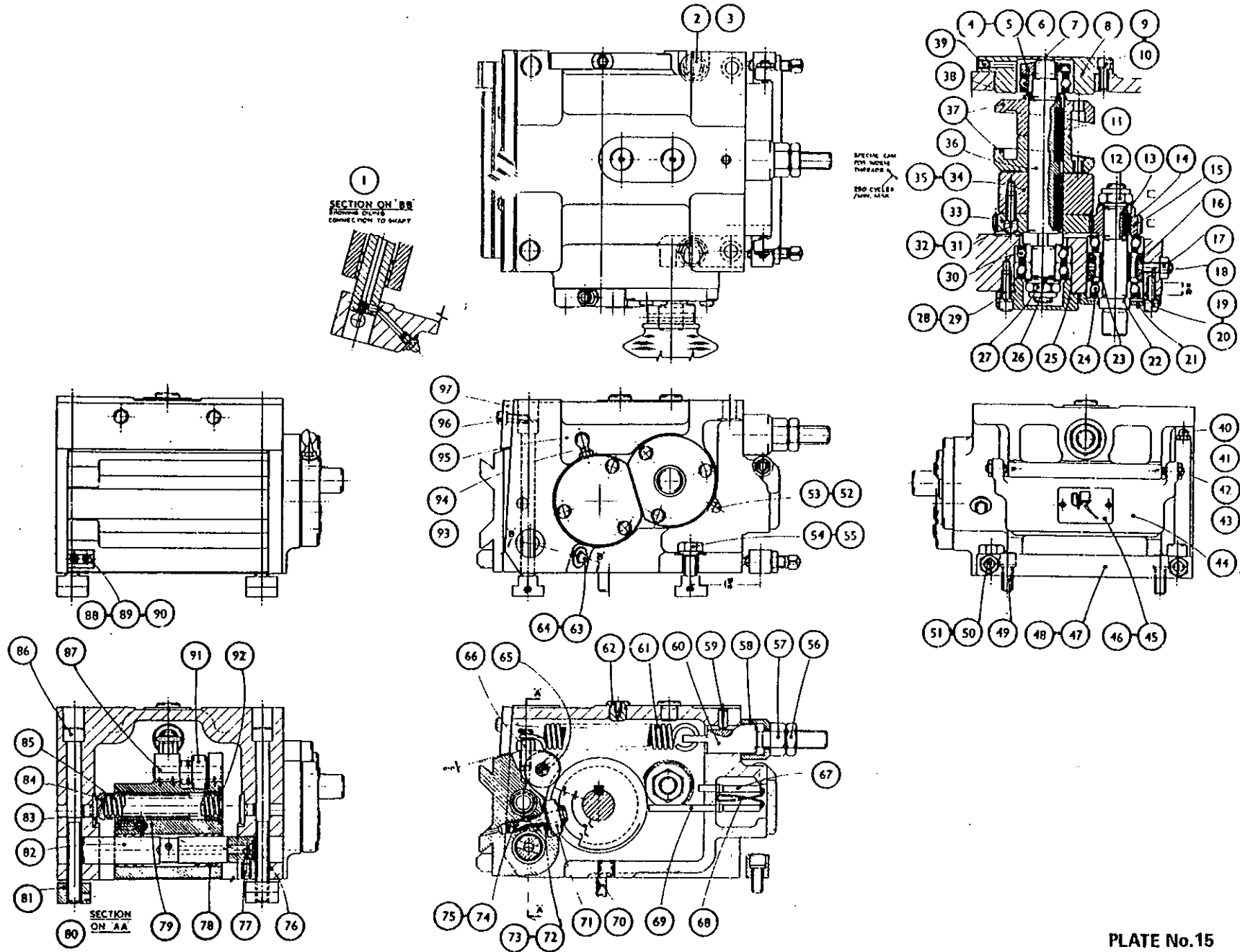

392 Z 4 CHASING ATTACHMENT

Section 392 MK. I

2 1/4" - 6, 6 1/2" - 6 MACHINES

INDEX NO.	PART NO.	TITLE	INDEX NO.	PART NO.	TITLE
1	192X147	Plug	29	392V150	Relief Cam
2	182/0410	Socket Set Screw, Taper Point, 1/4" B.S.F. x 5/8" long	30	392X146	Driven Gear
3	392X108	Slide Bush	31	154/04	Spring Washer, 1/4" dia.
4	392X109	Slide Shaft	32	155/0412	Socket Head Cap Screw, 1/4" B.S.F. x 3/4" long
5	182/0410	Socket Set Screw, Taper Point, 1/4" B.S.F. x 5/8" long	33	SB59	Light Ball Angular Contact Bearing, 20mm
6	192X123	Thrust Pad	34	153/42	Brass Pad for 2 B.A.
7	392X120	Spring Plunger	35	179/204	Socket Set Screw, Cup Point, 2 B.A. x 1/4" long
8	192X122	Lead Spring	36	150/12	Slotted Locknut, 3/4" dia., 22 T.P.I.
9	392Y107	Slide	37	392X102	End Cap
10	392X113	Lead Roller Pin	38	155/0416	Socket Head Cap Screw, 1/4" B.S.F. x 1" long
11	124/0205	Parallel Dowel, Silver Steel, 1/16" dia. x 5/16" long	39	154/04	Spring Washer, 1/4" dia.
12	392X143	Thrust Washer	40	121/0828T	Square Key, Tapped, 1/4" x 1.3/4" long
13	392X112	Lead Roller	41	121/1028T	Square Key, Tapped, 5/16" x 1.3/4" long
14	392X118	Locating Pin	42	130/08	Flat Washer, 1/2" dia.
15	392X142	Oil Pipe	43	203/08	Selflocking Nut, 1/2" B.S.F.
16	R.F-5	Heim Unibal Spherical Rod End	44	121/0814T	Square Key, Tapped, 3/16" x 7/8" long
17	173/05L	Locknut, 5/16" B.S.F.	45	392X131	Driving Gear
18	392X115	Spring Rod	46	392X129	Outer Spacer
19	556X112B	Spring	47	182/0516	Set Screw, Taper Point, 5/16" B.S.F. x 1" long
20	392X117	Spring Housing	48	173/05	Hexagon Nut, 5/16" B.S.F.
21	392X116	Spring Bush	49	392X128	Inner Spacer
22	173/05	Hexagon Nut, 5/16" B.S.F.	50	154/04	Spring Washer, 1/4" dia.
23	173/05L	Hexagon Locknut, 5/16" B.S.F.	51	155/0412	Socket Head Cap Screw, 1/4" B.S.F. x 3/4" long
24	392X147	Bearing Support	52	130/10	Flat Washer, 5/8" dia.
25	273/20	Light Roller Journal, 20mm	53	203/10L	Selflocking Nut, Thin, 5/8" B.S.F.
26	392X125	Spacer	54	392X103	Thrust Cap
27	-	Lead Cam. See 392Z5 & 6, 592Z6 & 7	55	SB59	Light Ball Angular Contact Bearing, 20mm
28	392V126	Camshaft	56	392X127	Drive Shaft

Continued.....

List of Parts for
Plate No. 16
(Drawing No. 392 Z 4)

WHEN ORDERING SPARE PARTS ALWAYS QUOTE THE INSPECTION NUMBER OF THE MACHINE

192 Z 1B CHASING ATTACHMENT MK. III

6 $\frac{1}{4}$ "-6, 2 $\frac{1}{4}$ "-6 MACHINES. SECTION 192

INDEX NO.	PART NO.	TITLE
72	124/0205	Parallel Dowel, 1/16" dia. x 5/16" long
73	192X.143	Thrust Washer
74	192X	Lead Roller Pin
75	182	Socket Set Screw, Taper Point, 1/4" B.S.F. x 1/2" long
76	192	Plug
77	182	Socket Set Screw, Taper Point, 1/4" B.S.F. x 1/2" long
78	192X	Slide Bush
79	192Y.	Slide
80	-	Section on AA
81	192X.132	T Nut
82	192X.109	Slide Shaft
83	192X.123	Thrust Pad
84	192X.120	Spring Plunger
85	192X.122	Lead Spring
86	155/0672	Socket Head Cap Screw, 3/8" B.S.F. x 4 1/2" long
87	192X.110	Relief Roller Pin
88	192X.161	Stop
89	156/408	Socket Head Cap Screw, 4 B.A. x 1/2" long
90	154/4	Spring Washer, for 1/4" dia.
91	192X.111	Relief Roller
92	192X.121	Spring Cap
93	212/9004	Autofub Nipple, 1/4" B.S.F.
94	210/1725	Indicator Washer, Yellow, for 9/16" dia.
95	192Z.101B	Main Body
96	155/0410	Socket Head Cap Screw, 1/4" B.S.F. x 3/4" long
97	192X.105A	Cover Plate

List of Parts for
Plate No. 15
(Drawing No. 192 Z 1B)

WHEN ORDERING SPARE PARTS ALWAYS QUOTE THE INSPECTION NUMBER OF THE MACHINE

Handwritten text, possibly a signature or date, located at the bottom right of the page.

SYNCHRONOUS DRIVE: SECTION 390J

2 1/4" - 6 BAR MACHINES

⑥
SCREW INTO TAPPED HOLES
PROVIDED IN BODY FLANGE.

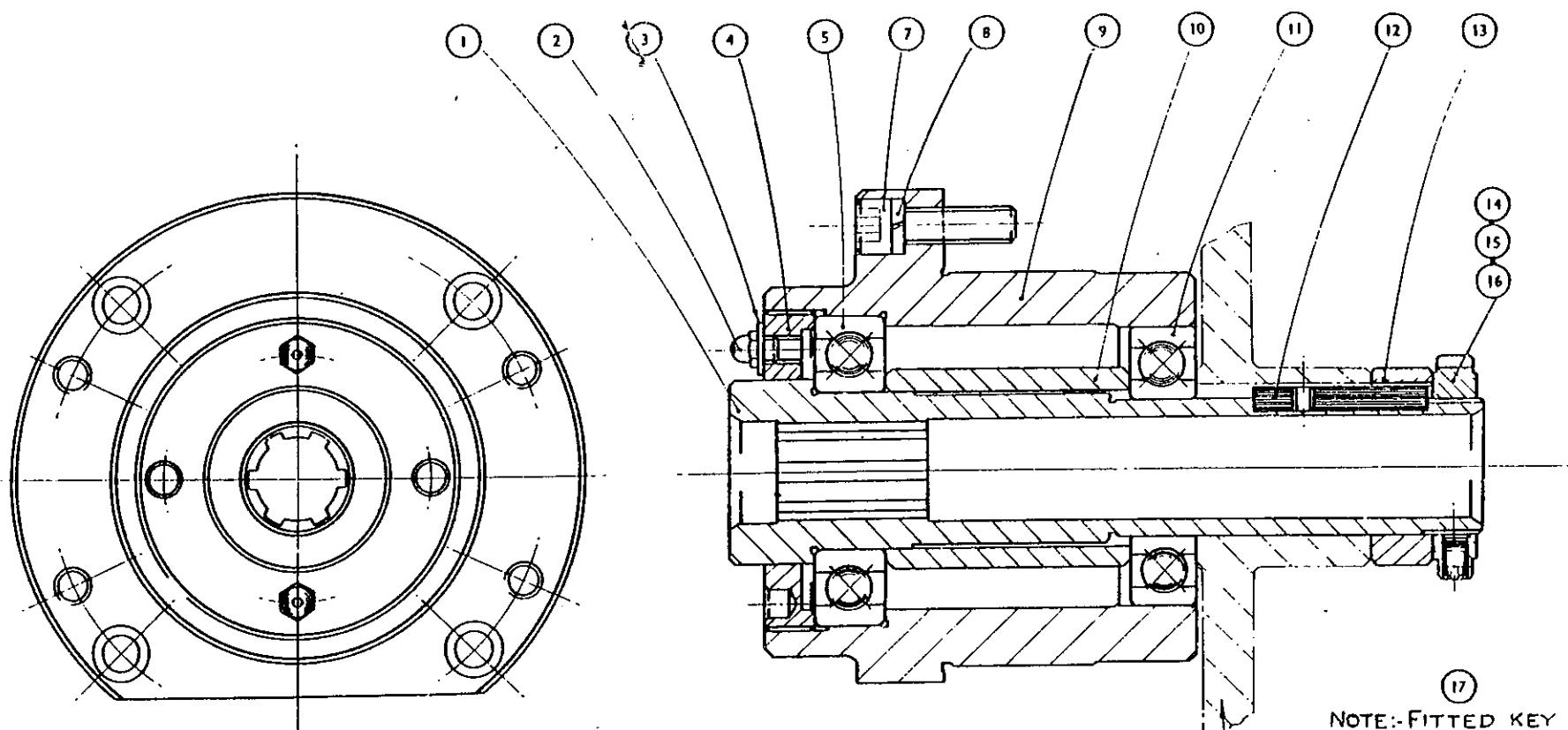

⑬
NOTE:- FITTED KEY &
SHAFT MUST BE
INSPECTED WITH
GAUGE MPG 859.

⑱
FOR APPLICATION DRG. AND
GEARS AVAILABLE SEE 390 Z 11.

PLATE No. 14
(Drawing No. 390V5)

192 Z 1B CHASING ATTACHMENT MK. III

6 $\frac{1}{4}$ "-6, 2 $\frac{1}{4}$ "-6 MACHINES. SECTION 192

INDEX NO.	PART NO.	TITLE	INDEX NO.	ART NO.	TITLE
1	—	Section on BB showing oil connection to shaft	39	192X.126	Camshaft
2	166/0620	Socket Head Cap Screw, $\frac{3}{8}$ " B.S.F. x 1 $\frac{1}{4}$ " long	40	192BY151	Standard Lead Cam
3	130/06	Flat Washer, for $\frac{3}{8}$ " dia.	41	192X.125	Spacer
4	163/42	Brass Pad, for 2 B.A.	42	176/0406	Socket Set Screw, Cup Point, $\frac{1}{8}$ " B.S.F. x $\frac{5}{16}$ " long
6	179/204	Socket Set Screw, Cup Point, 2 B.A. x $\frac{1}{4}$ " long	43	212/04	Autolub Nipple, $\frac{1}{4}$ " B.S.F.
6	160/10	Slotted Locknut, $\frac{5}{8}$ " x 22 T.P.I.	44	210/1726	Yellow Indicator Washer, for 9/16" dia.
7	268/17	Light Ball Journal, 17 mm bore	45	173/04L	Hexagon Locknut, $\frac{1}{2}$ " B.S.F.
8	192X.102	End Cap	46	192/0412	Socket Set Screw, Taper Point, $\frac{1}{4}$ " B.S.F. x $\frac{1}{2}$ " long
9	166/0410	Socket Head Cap Screw, $\frac{1}{4}$ " B.S.F. x $\frac{5}{8}$ " long	47	192X.105A	Oil Cover
10	164/04	Spring Washer, for $\frac{1}{4}$ " dia.	48	192X.146	Lubrication Plate
11	121/0824	Key, $\frac{1}{2}$ " square x 1 $\frac{1}{4}$ " long	49	166/404	Round Head Set Screw, 4 B.A. x $\frac{1}{2}$ " long
12	203/08	Locknut, $\frac{1}{2}$ " B.S.F.	50	192X.119	Adjustment Strip
13	130/08	Flat Washer, for $\frac{1}{2}$ " dia.	51	156/0612	Socket Head Cap Screw, 5/16" B.S.F. x $\frac{3}{4}$ " long
14	121/0610	Key, 3/16" square x $\frac{5}{8}$ " long	52	164/05	Spring Washer, for 5/16" dia.
15	192X.131	Driving Gear	53	188/0620	Square Head Set Screw, 5/16" B.S.F. x 1 $\frac{1}{4}$ " long
16	192X.129	Outer Spacer	54	173/05L	Locknut, 5/16" B.S.F.
17	173/05	Hexagon Nut, 5/16" B.S.F.	55	210/1726	Yellow Indicator Washer, for 9/16" dia.
18	182/0616	Socket Set Screw, Taper Point, 5/16" B.S.F. x 1" long	56	212/04	Autolub Nipple, $\frac{1}{4}$ " B.S.F.
19	166/0412	Socket Head Cap Screw, $\frac{1}{4}$ " B.S.F. x $\frac{3}{4}$ " long	57	130/06	Flat Washer, for $\frac{3}{8}$ " dia.
20	164/04	Spring Washer, for $\frac{1}{4}$ " dia.	58	167/0620H	Hexagon Head Set Screw, Hardened, $\frac{3}{8}$ " B.S.F. x 1 $\frac{1}{4}$ " long
21	192X.104	End Cap	59	173/08L	Hexagon Locknut, $\frac{1}{2}$ " B.S.F.
22	182X.127	Drive Shaft	60	173/08	Hexagon Nut, $\frac{1}{2}$ " B.S.F.
23	192X.128	Inner Spacer	61	192X.117	Collar
24	SB 58	Light Ball Angular Contact, 17 mm bore	62	143/0808A	Mills Pin, $\frac{1}{4}$ " dia. x $\frac{1}{2}$ " long
25	192X.103	Thrust Cap	63	192X.116	Spring Adjuster
26	130/08	Flat Washer, for $\frac{1}{2}$ " dia.	64	192X.115	Tension Spring,
27	203/08	Locknut, $\frac{1}{2}$ " B.S.F.	65	192X.159	Plug
28	164/04	Spring Washer, for $\frac{1}{4}$ " dia.	66	212/04	Autolub Nipple, $\frac{1}{4}$ " B.S.F.
29	166/0412	Socket Head Cap Screw, $\frac{1}{4}$ " B.S.F. x $\frac{3}{4}$ " long	67	210/1726	Yellow Indicator Washer, for 9/16" dia.
30	SB 58	Light Ball Angular Contact, 17 mm bore	68	182/0408	Socket Set Screw, Taper Point, $\frac{1}{4}$ " B.S.F. x $\frac{1}{2}$ " long
31	166/0412	Socket Head Cap Screw, $\frac{1}{4}$ " B.S.F. x $\frac{3}{4}$ " long	69	192X.114	Spring Anchor
32	164/04	Spring Washer, for $\frac{1}{4}$ " dia.	70	192X.142A	Oil Pipe
33	192X.130	Driven Gear	71	192X.143	Thrust Washer
34	192V.160A	Relief Cam		192X.160	Oil Pipe
36	1928X.103	Special Cam for Worm Threads, 260 Cycles per Minute maximum		192X.118A	Locator
				192X.112	Lead Roller

List of Parts for
Plate No. 15
(Drawing No. 192 Z 1B)

WHEN ORDERING SPARE PARTS ALWAYS QUOTE THE INSPECTION NUMBER OF THE MACHINE