

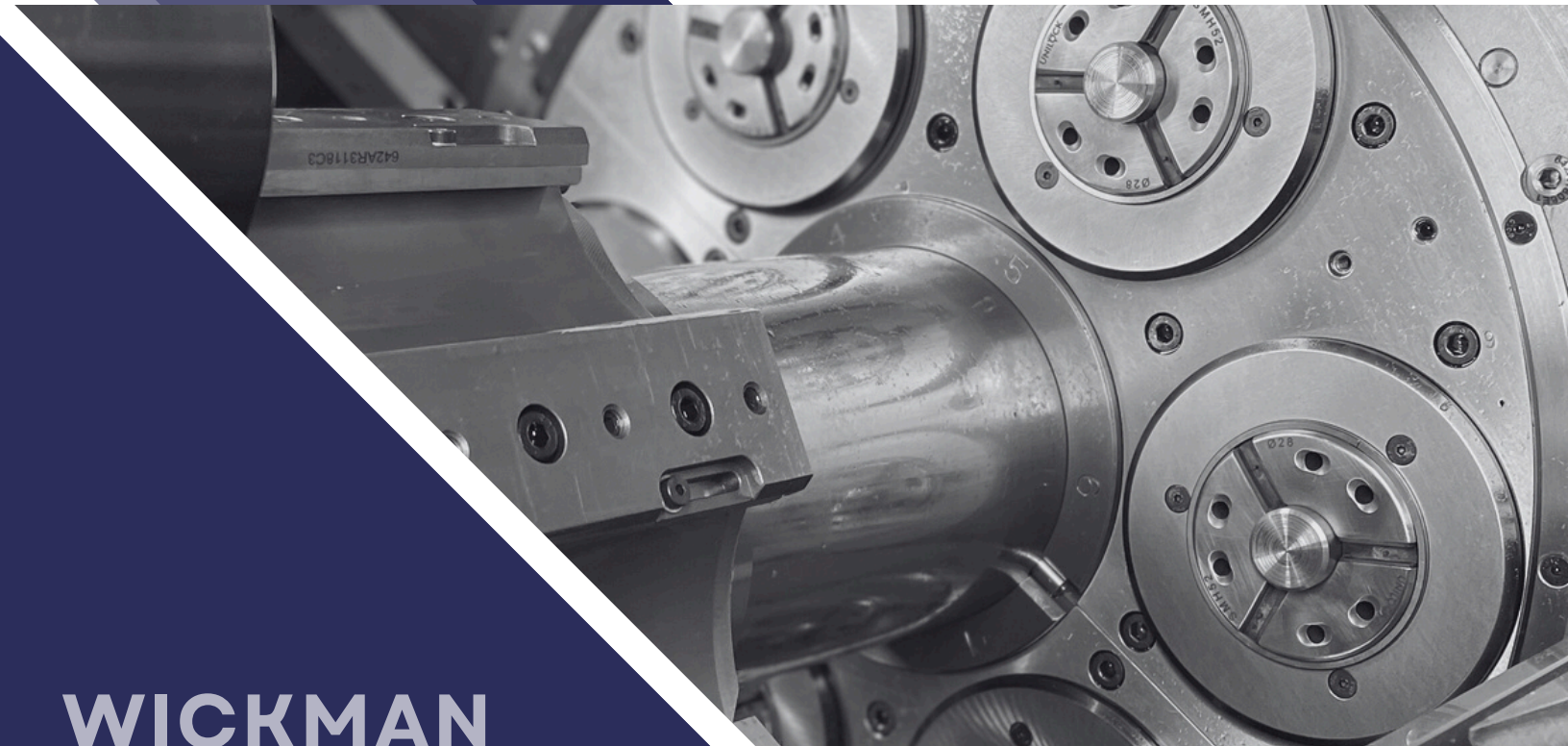

PIÈCES DÉTACHÉES



WICKMAN

1" 3/4-8

TAJMAC-FRANCE

Your attention please !

The references at the foot of each page show that this manual was prepared in 1988.

Unfortunately it was never completed, probably due to the compiler being made redundant as a result of the drastic reductions in manpower which the company was forced to make during that difficult time.

The 'masters' were found in the company archives in February 2005. The manual was found to be complete and ready for printing apart from Section Five: Parts Lists and Machine Drawings. Whilst the lists of parts had been done, much of the artwork (with index numbers) was missing.

Unfortunately we do not have the resources at present to prepare new artwork so we have inserted at the appropriate point a scaled-down print of the appropriate drawing on which all of the relevant part numbers are shown. Where we have done this, the list of parts has been marked 'REFER TO DRAWING SHOWING ALL PART NUMBERS'.

We trust that this will be acceptable and we are pleased that at last we now have a manual dedicated to the 1.3/4" 8-Spindle machine. Hitherto we could only offer the 2.5/8" 6-Spindle manual with a few inserted pages for the 1.3/4"-8.

Wickman Coventry Limited

TABLE OF CONTENTS

<u>DESCRIPTION</u>	<u>PAGE</u>
TABLE OF CONTENTS	1
PREFACE	2
HEALTH AND SAFETY	2-3
MACHINE SIZE / MODEL RANGE	4
MACHINE SERIAL / INSPECTION NUMBER	4
DETAILED CONTENTS LIST - Refer below for Summary List	5-6
SUMMARY CONTENTS LISTING	
Section One: Installation	7-8
Section Two: Lubrication Charts and Specifications	9-12
Section Three: Preventative Maintenance Schedule	13-18
Section Four: Machine Construction & Maintenance Procedures	19-72
Section Five: Parts Lists and Machine Drawings	73

WICKMAN COVENTRY LIMITED

Automatic House, Discovery Way, Leofric Business Park, Binley, Coventry CV3 2 TD
Telephone +44 (0) 24 7654 7900 Spares +44 (0) 24 7654 7910
Facsimile +44 (0) 24 7654 7920 E-mail: sales@wickman.co.uk

TABLE OF CONTENTS

<u>DESCRIPTION</u>	<u>PAGE</u>
TABLE OF CONTENTS	1
PREFACE	2
HEALTH AND SAFETY	2-3
MACHINE SIZE / MODEL RANGE	4
MACHINE SERIAL / INSPECTION NUMBER	4
DETAILED CONTENTS LIST - Refer below for Summary List	5-6
SUMMARY CONTENTS LISTING	
Section One: Installation	7-8
Section Two: Lubrication Charts and Specifications	9-12
Section Three: Preventative Maintenance Schedule	13-18
Section Four: Machine Construction & Maintenance Procedures	19-72
Section Five: Parts Lists and Machine Drawings	73

Wickman Bennett Machine Tool Co. Ltd., operate a policy of continual improvement. We therefore reserve the right to change the specifications and illustrations without notice.

PREFACE

This Manual provides the basic information and instructions that are necessary for the maintenance/servicing of the Wickman 1.3/4"-8, 1.3/4"-8S (arranged for spindle stopping) and the 50mm-8 Spindle Bar Automatic Lathes with relay logic control.

The contents will familiarize the reader with the machine construction specifications, installation procedure, safety at work and all the relevant aspects of the machine.

The manual should be read thoroughly. It will enable the Engineer to gain the knowledge required for the correct and efficient servicing of the machine.

An Operator's Handbook is also available for the 1.3/4"-8, 1.3/4"-8S and 50mm-8 machines.

HEALTH AND SAFETY

Health and Safety at Work Act, 1974 - U.K. users only.

In accordance with the requirements of the Health and Safety at Work Act 1974, this manual embodies the necessary information to ensure that the machine tool can be maintained properly and with safety. It should be clearly understood that the engineer must be properly trained, have the required skills and be authorised to maintain the machine.

If it should arise that the person authorised to maintain the machine is undergoing training, he must be under the close supervision of another skilled and authorised person.

Adequate information is provided to enable the machine to be serviced and maintained in a satisfactory condition by engineers and electricians who have the necessary skills and authority. We recommend that a 'Permit to Work' system as detailed in BS5304; 1988 entitled "Safety of Machinery", should be operated.

HEALTH AND SAFETY (Continued)

It is important that the various statutory regulations which are applicable, eg, 'The Protection of Eyes Regulations' are complied with.

Operating Discipline

- (I) A clean, neat and well ordered machine and working area is the first essential of safety at work.
- (II) All guards, cover plates, cabinet doors and the tooling area guards must be in place or closed before any production run commences.
- (III) Never leave articles lying on any working surface where there is a danger that they may be dislodged by: any moving part of the machine, vibration, etc.
- (IV) Never wear rings, watches, neck-ties or loose-sleeved clothing when working on the machine.
- (V) Never operate the machine in excess of its rated capacity.
- (VI) Know where the EMERGENCY STOP BUTTON is.
- (VII) Never reach across a moving or rotating part of the machine
- (VIII) Never enter the tooling area or any other working part of the machine when the machine is running on production.
- (IX) When tool setting, changing tools or making adjustments, never enter the tooling area until the machine has been shut down.
- (X) When carrying out maintenance work, never enter any part of the machine, either mechanical or electrical, until the machine has been shut down and the isolator on the electrical control panel is in its "off" position, disconnecting the power supply.
- (XI) When working with lubrication oils and cutting oils of the soluble and straight cutting oil types, cleanliness is essential. Precautions must be taken to avoid all unnecessary contact with oil by ensuring that the machine's protective devices against coolant and oil spray are correctly closed and that protective clothing is worn. Never wear oil soaked clothes or place oily rags or tooling in the pockets of wearing apparel. Always wash oil from the body as soon as possible after contamination.

The Safe Operation Of Work Holding Devices

Collet equipment and collet operating mechanisms must always be kept in first class condition, in order to ensure that the bar is securely gripped to withstand all the applied cutting forces. Tooling area guards must always be closed when the machine is in the "run" condition.

MACHINE SIZE / MODEL RANGE

WICKMAN 2.5/8"-6 SPINDLE BAR AUTOMATIC LATHE
WICKMAN 2.5/8"-6 SPINDLE BAR AUTOMATIC LATHE WITH SPINDLE STOPPING
WICKMAN 2.5/8"-6 SPINDLE BAR AUTOMATIC LATHE WITH DOUBLE BAR FEED

WICKMAN 3.1/4"-6 SPINDLE BAR AUTOMATIC LATHE

WICKMAN 1.3/4"-8 SPINDLE BAR AUTOMATIC LATHE *
WICKMAN 1.3/4"-8 SPINDLE BAR AUTOMATIC LATHE WITH SPINDLE STOPPING *

WICKMAN 50mm-8 SPINDLE BAR AUTOMATIC LATHE *
WICKMAN 50mm-8 SPINDLE BAR AUTOMATIC LATHE WITH SPINDLE STOPPING

WICKMAN 7.1/4"-6 SPINDLE HYDRAULIC CHUCKING AUTOMATIC LATHE
WICKMAN 7.1/4"-6 SPINDLE HYDRAULIC CHUCKING AUTOMATIC LATHE WITH
DOUBLE INDEXING

WICKMAN 6"-8 SPINDLE HYDRAULIC CHUCKING AUTOMATIC LATHE
WICKMAN 6"-8 SPINDLE HYDRAULIC CHUCKING AUTOMATIC LATHE WITH
DOUBLE INDEXING

This Manual applies only to the Machines marked *, above.

MACHINE SERIAL / INSPECTION NUMBER

In the event that queries arise with regard to the maintenance of the machine, it is important to note the following details which would need to be given to Wickman Bennett in all correspondence, ie:

Machine Inspection/Serial number. Machine size and Model.

The machine Inspection/Serial Number must always be quoted and is stamped on the machined-rim of the Tray of the machine, on the left hand side, close to the Operators position. Additionally the number is also engraved on the machine Manufacturing Plate (WSP500) which is affixed to the Main Drive Housing casting at the rear of the machine.

Reference to this number will facilitate any service that may be required.

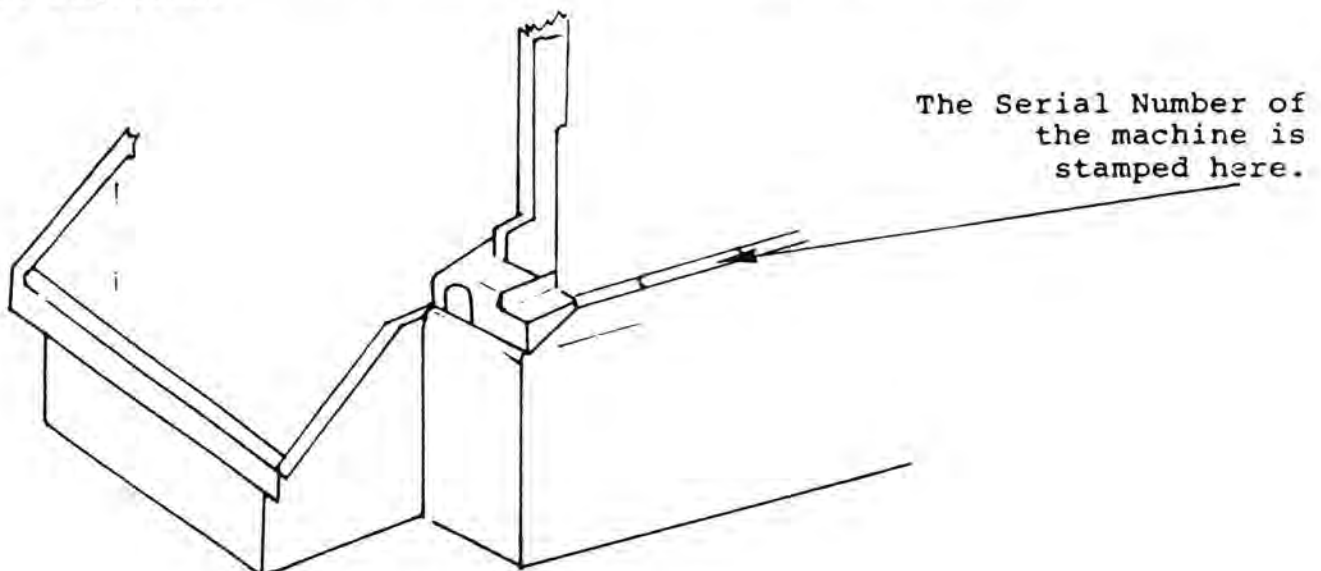

DETAILED CONTENTS LIST

PAGE

SECTION ONE - INSTALLATION

7

- 1.1 Lifting the Machine
- 1.2 Siting and Foundations

SECTION TWO - LUBRICATION CHARTS AND SPECIFICATIONS

9

- 2.1 General Description
- 2.2 Summary of Lubricants
- 2.3 Lubrication Chart 1.3/4"-8, 1.3/4"-8S and 50mm-8

SECTION THREE - PREVENTATIVE MAINTENANCE SCHEDULE

13

- 3.1 1000 Hour Procedures
- 3.2 2000 Hour Procedures
- 3.3 4000 Hour Procedures
- 3.4 12000 Hour Procedures

SECTION FOUR - MACHINE CONSTRUCTION & MAINTENANCE PROCEDURES

19

- 4.1 Spindle Speed Drive
- 4.2 Spindle Drum
- 4.3 Workspindles for the 1.3/4"-8 Spindle Machine
- 4.4 Front Bearing End Float, Collets and Collet Adjustment and Feed Tube Removal
- 4.5 Workspindles 1.3/4"-8S (arranged for spindle stopping)
- 4.6 Dismantling (1.3/4"-8S Machine)
- 4.7 Workspindles for the 50mm-8 Spindle Bar Automatic
- 4.8 Collet Operation and Bar Feed
- 4.9 Indexing and Drum Locking
- 4.10 Feed Drive
- 4.11 The Main Camshaft

- 4.12 The Upper Camshaft
- 4.13 Centre Tool Block & Longitudinal Slides Operating Mechanism
- 4.14 Changing Feed Stroke
- 4.15 Changing Fast Motion Approach Stroke
- 4.16 Centre Block and Longitudinal Slides
- 4.17 Cross Slide Operating Mechanism
- 4.18 Bar Stop and Operation
- 4.19 Feed Brake Interlock & Bar Exhaustion Bar Feed Trip
- 4.20 Coolant
- 4.21 Stock Carriage
- 4.22 Swarf Conveyor

SECTION FIVE - PARTS LISTS AND MACHINE DRAWINGS

SECTION ONE - INSTALLATION

1.1 Lifting the Machine

When planning the siting of a machine consider the space required for chip removal, bar loading and servicing, i.e. centre-shaft removal. Dimensions of suitable lifting bars for use with a crane are shown on the Foundation Drawing Fig.1.1. Slings must not lie against the machine during hoisting. Examine the position of the sling with tension on the rope before the full weight of the machine is lifted.

Where a crane is not available, the machine may be moved by "wedge" truck or rollers and continuous machined surfaces are provided on the underside of the machine tray to facilitate the operation. Rollers must be longer than the machine tray width.

Careful handling of the new machine will ensure accurate alignment.

1.2 Siting and Foundations

The machine should be installed on a level and stable foundation in order to ensure accurate alignment is maintained. A concrete base is recommended. It provides the most suitable foundation because of its stability and because it is less prone to distortion when laid down in adverse soil conditions.

The actual depth of concrete base must be determined to suit the prevailing soil conditions, which must be capable of supporting the machine, its ancillary equipment, its tooling and the concrete base itself.

The soil should be consolidated with crushed rock, pebbles and stones.

With the machine in position on the factory floor, level using the jacking screws provided in the machine tray. It is recommended that steel plates be placed between the floor and the screws. Longitudinal and lateral alignment levels can be checked with a precision level on the facings provided at both ends of the machine tray and on top of the spindle drum housing, see Foundation Drawing Fig.1.1. Wedges should be placed at the positions shown.

Foundation bolt holes are also provided for use where required, bolts to be embedded in the floor approximately 5in (125mm).

Where not bolted-down, machines can be grouted or cemented by any shop approved method.

Fig.1.1 Foundation Drawing

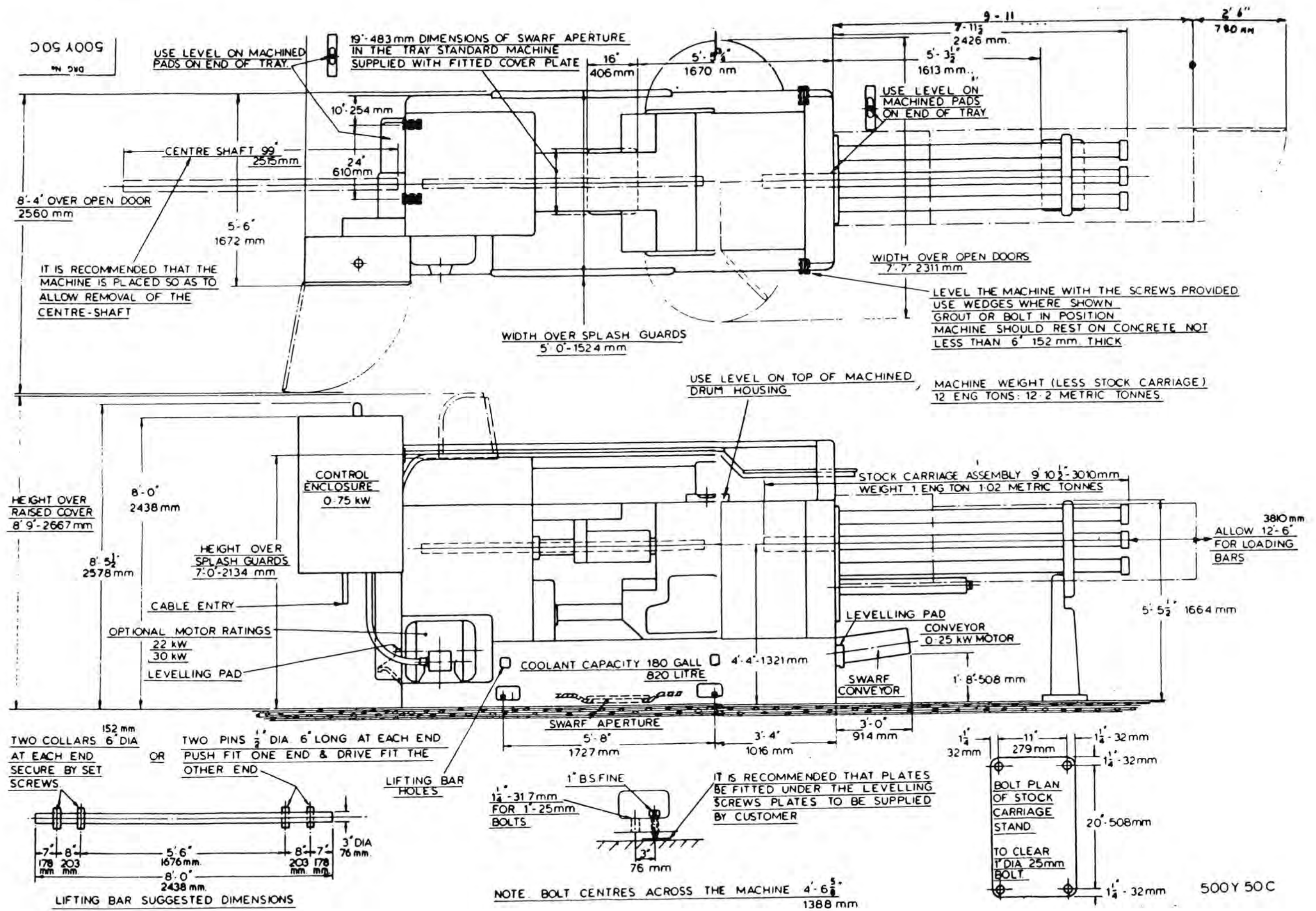

SECTION TWO - LUBRICATION CHARTS AND SPECIFICATIONS

2.1 General Description

The lubrication system has two separate parts with the two plunger pumps contained in the same unit and chain driven from the constant speed shaft. Access to the unit is through a cover on the lower face of the motor end of the main drive housing.

One side of the pump raises oil from the main drive housing sump and passes it through the lower Purolator filter to distributors which supply all points in the main drive housing. The circuit contains a pressure relief valve set at 10-15lbs/square inch (0.703-1.055kg/square cm), the excess oil being fed to the upper camshaft oil bath. The bath supplies a number of drip points, and should be kept clean of dirt and grease. A strainer box fitted to the pump intake must not be allowed to become choked. Examine twice a year and clean the sump if necessary. Check the oil level in the sump through a sight glass situated in the front of the main drive housing and fill at regular intervals.

The other side of the pump unit draws oil from the tank in the beam through the upper Purolator filter and passes it to sight feed headers for the spindles and to distributors for drum housing and cross slide feeds. The circuit contains a pressure relief valve set at 10-15 lbs/square inch (0.703-1.055 kg/square cm.) and contained in a block. When a "Flush" button in the block is pressed, the relief valve is blocked and a surge of oil is passed to the spindles and drum housing feeds. The "Flush" button should be pressed daily on machine start up.

Oil in the drum housing should be maintained to the level indicated on the rear inside face of the drum housing. Keep clean of grease and soluble coolant contamination.

A priming plug is provided on the Purolator housing for filling or for releasing air locks. Purolator handles should be turned clockwise two or three turns each day to clear the element of foreign matter. The units should be removed twice a year and the element cleaned with paraffin and a soft brush. Use a solvent on gummy deposits.

A Summary of Lubricants, fig. 2.1 specifies the I.S.O. standard for all the lubricants used on the machines.

Fill all grease nipples with grease, etc., as indicated on the chart fig. 2.2. Use ball bearing grease sparingly in the spindle nose labyrinth seal nipples.

Concerning Lubrication

- (a) Check all oil levels in tanks and sumps. They must not fall below the levels indicated.
- (b) Frequent checks of the spindle sight-feeds are necessary; also check that the main drive oil is circulating.
- (c) Turn Purolator filters daily: apply oil gun to all nipples and oil parts not served by the automatic system.

2.1 Summary of Lubricants

Wickman Oil Grade	1	2	3	4	5
Application	Light Spindle Oil	Air Line Lubrication for Cold Climates	Air Line Lubrication for Warm Climates	Centralised Lube. Air Line Lub'e Hyd. syst. Gen. Lub'e for Cold Climates	General Lubrication Centralised System for Warm Climates
B.P	Energol HL 40	Energol HL 50	Energol HL or HLP 65	Energol HLP 80	Energol HLP 100
CASTROL	Hyspin AWS 10	Hyspin AWS 22	Hyspin AWS 32	Hyspin AWS 46	Hyspin AWS 68
CENTURY	P79A	P313	PWLA	PWLB	PWLC
DUCKHAMS	Zircon 1	Zircon 3	Zircon 4	Zircon 5	Zircon 6
ESSO	Nuto H36	Nuto H40	Nuto H44	Nuto H48	Nuto H54
GULF	Harmony 34AW	Harmony 40AN	Harmony 43AW	Harmony 48AW	Harmony 54AW
MOBIL	Velocite oil No 6	Velocite oil No 10	DTE oil light or DTE 24	DTE oil med. or DTE 25	DTE oil heavy med. or DTE 26
PETROFINA	Cirkan 15	Hydran 21	Hydran 31	Hydran 31	Hydran 37
SHELL ISO VG NO	10	22	37	46	68
TEXACO	Spintex 60	Spintex 100	Rando HD.A	Rando HD.B	Rando HD.C
VAUGHAN	KSO 5L	KSO No.1	Evco Med. Hyd. or Hydrodrive HP 150	Evco Heavy Hyd. or Hydrodrive HP 200	Evco Extra Heavy Hyd. or Hydrodrive HP 300

Where alternative grade references are given it is recommended that the lighter grade (lower number) is used unless oil consumption is excessive.

For Slideways Grade 5 is suitable for use with oil-base coolants and Grade 7 for use with water-base coolants.

Wickman Oil Grade	6	7	Wickman Grease Grade	1	2
Application	Reduction Units (Swarf conveyor)	Slideways		GREASES	
				Electric Motors	Spindle Nose Cap
B.P	Energol CS 300	Energol HP 20-C		Ener Grease LS3	Ener Grease LS3
CASTROL	Alpha 417	Magna BD		Spheerol AP3	Spheerol AP3
CENTURY	WLP	428AP		Lupus 3	Lupus 3
DUCKHAMS	Galrex 9	Adglide 6		Admax 13	Admax 13
ESSO	Esstic 78	Febis K73		Beacon 2/3	Beacon 2/3
GULF	Mechanism LP 85	Gulway 52 or Slidway, 52		Gulfcrown No. 3	Gulfcrown No. 3
MOBIL	DTE oil BB	Vectra Oil		Mobilplex 48	Mobilplex 48
PETROFINA	Solna 58	Artac 37		Marson HTL 3	Marson HTL 3
SHELL ISO VG NO:	220	68 or 320		Alvania R2 & R3	Alvania R2 & R3
TEXACO	Regal GR & O	Way Lubricant D		Regal Starfal Premium 3	Regal Starfal Premium 3
VAUGHAN	Cosmolub-ric EHC	Way Lubricant		Evco BB No. 3 Grease	*Cosmolube Grease/No4 Grease

REMARKS:

For Slideways Grade 5 is suitable for use with oil-base coolants and Grade 7 for use with water-base coolants.

* Re: Cosmolube No. 4: Use sparingly and only in nose cap seals.

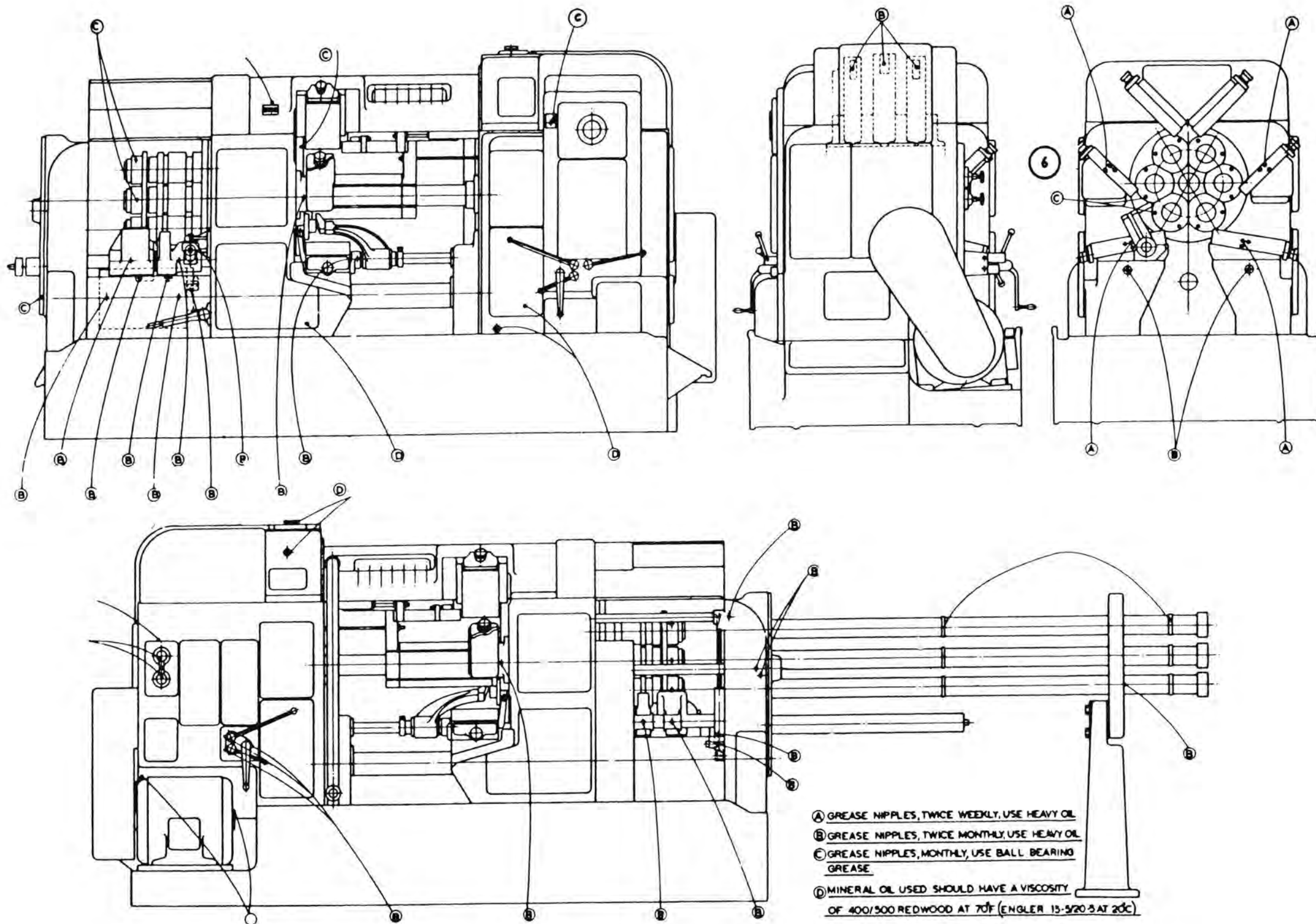

SECTION THREE - PREVENTATIVE MAINTENANCE SCHEDULE

3.1 1000 Hour Procedures

Work Schedule to be carried out after 200, 1,000, 2,000, 3,000 hours running, at 1,000 hour intervals thereafter.

Cross Slide Felt Wipers & Aprons:	Inspect and check for damage. Remove swarf particles.
Change Gear Securing Nuts:	Check tightness.
Attachments and Tooling Equipment Securing Nuts:	Check tightness.
Chasing Attachment Drive (if fitted):	Inspect drive chain, check tension, Remove covers and check lubrication. Push back gaiter covers on universal joints and inspect.
Feed Drive - Brake Clutch:	} Inspect and check adjustment (see handbook and machine plate). } Check drive chain tension
Feed - Fast Clutch:	
Threading:	
Drive Clutch:	
Collet Operating Shoe:	} Inspect for correct alignment and lubrication. (Renew when worn).
Bar Feed Shoe	
Eight Collet Operating Sleeves:	Inspect for correct alignment and movement to avoid overheating.
Bar Feed Mechanism:	Check adjustment.
Bar Feed Mechanism Aligning Ring:	Inspect for alignment.
Cyclic System:	Inspect for leakage caused by loose connections and damaged tubing.
Upper Camshaft:	Check tightness of bolts on coupling between wormwheel and shaft.
Main Block Positive Stop:	Check for excessive pressure.
Independent Slides Positive Stop:	Check for excessive pressure.
Cross Slide Positive Stops:	Check for excessive pressure.
Drum Housing:	Clean lubricating oil sumps.
Main Drive Housing:	
Coolant System:	Clean tray, taps, pipes and ducts (including manifolds).
Bar Feed Tube Assemblies:	Remove and thoroughly clean. Inspect Feeders.
Collet Tubes, Collets:	Remove and thoroughly clean. Inspect Collets.

Spindle Bore and Collet Seating:	Clean. Inspect collet keys for excessive wear.
Longitudinal Slides:	Pull quadrants back, push forward to check free movement. Adjust gib strip if required.
Spindle Speed and Feed Change Gears:	Inspect lubrication.
Main Drive Housing:	All chain drives, check adjustment and sprocket alignments.
All Cams and Cam Rollers:	Inspect for excessive wear, oil, rollers and pins.
Spindle Drum:	Check end float (see handbook).

3.2 2000 Hour Procedures

Work Schedule to be carried out after 200, 2,000, 4,000 hours running, at 2,000 hour intervals thereafter.

Intake Strainer for Pump on Continuous Lubrication System:	Inspect and Clean.
Interlube Cyclic Metered Lubrication System if fitted:	Check frequency of operation.
Main Drive Belts:	Remove cover, check belt tension and inspect for excessive wear.
Handwind Interlock System:	Inspect and check (see handbook).
Bar Feed Spring:	Check setting.
Control Panel Wire Connections:	Check for tightness.
Control Panel:	Hand operate contactors and relays, ensure free action.
'PUROLATOR' Metal Edge Filter:	Remove, clean filter and case, refit.
'PUROLATOR' "Micronic" Cartridge Filter:	Remove bowl, renew cartridge.
Upper and Intermediate Cross Slides:	Strip, Clean, refit and adjust gib strip.
4th & 5th Station Longitudinal Slides:	Strip, Clean, refit and adjust gib strip.
Chasing Attachment (if fitted):	Strip, Clean, inspect for wear, refit.
Stock Carriage:	Remove springs, clean, regrease, renew as necessary.
Feed Tube: Steady Bushes:	Examine and renew if worn.
Spindles, Collet Operating Toggles:	Strip and examine for wear. (Renew in matched pairs).
Pulley Shaft:	Check for oil leak adjacent to pulley, and renew oil seal if necessary.
Spindles:	Remove collet operating sleeve, examine internal form. Check for correct movement.
Conveyor:	Remove from machine and clean thoroughly. Examine for damage, adjust and refit as necessary.
Spindle Drum:	Check indexing, measure over index. (see handbook).

Drum Locking:	Check setting (see handbook).
Drum Latch:	Check setting, inspect for excessive wear.
Interlube Cyclic Metered Lubrication if fitted:	Drain and clean reservoir.
Centre Block:	Drain and flush. Clean Strainer on guide block. Adjust gib strip if required. Do not over-tighten.
Attachments:	Strip attachment slides, clean, refit and adjust. Inspect, replace worn items. Gears, bearings, splined shafts, clutch parts etc.
Switches:	Check setting, ensure free action, inspect for mechanical damage, check securing screws.
Flexible Electrical Conduits:	Inspect for damage.
Lower Cross Slides:	Strip, clean, refit and adjust gib strip. Replace aprons and felt if worn.
Conveyor Drive Motor Bearings:	See manufacturer's Service Sheets or follow a known procedure for low power motor maintenance.
Upper Camshaft Housing:	Check oil supply to drip tray and outlets.

3.3 4000 Hour Procedures

Work Schedule to be carried out after 4,000 and 8,000 hours running, at 4,000 hour intervals thereafter.

Coolant Pump (Gear Type Only):	Strip and Clean, examine gears, shafts and gland. Renew as required. Refit.
Continuous Lubrication System:	Remove and strip pump, clean and examine for wear. Renew as required. Refit.
Main Drive Housing:	Examine lower and upper camshaft. Worm and Wormwheel. Drives for wear. Replace worn gears.
Spindle Drum, Spindle: Drive Gears:	Examine for wear. Renew if worn.
Cross Slides, Upper and Intermediate:	Replace return springs.
All Chain Drives:	Renew worn chains.
Drum Locking:	Renew Cam Roller and Pin if necessary. Examine Cam and Renew if worn.
Bar Stop Mechanism:	Strip Covers and examine cams, rollers and pins. Replace if worn.
Spindle Assembly:	Remove feed tube assemblies and examine. Replace worn bearings. Remove spindle nose caps, examine piston ring seals, replace if worn.

3.4 12000 Hour Procedures

Work Schedule to be carried out after 12,000 hours running.

Longitudinal Motion:	Examine bushes, and pins, replace as necessary.
Camshafts:	Examine for worn keys and keyways.
Cross Slide Operation:	Dismantle front and rear cam levers and renew bushes. Remove links and cross slide levers and renew bushes and pins and worn shafts.
Main Drive Housing:	Examine initial drive shafts (3). Replace if worn.
Drum Housing & Drum:	Withdraw spindle drum, examine front bearing area on drum & in housing for excessive wear and damage. (Consult Wickman Engineer). Examine drum seal, replace if worn.

SECTION FOUR - MACHINE CONSTRUCTION AND MAINTENANCE PROCEDURES

4.1 Spindle Speed Drive

The initial machine drive described below covers that part of the drive from the motor to the spindles and indicates where the drive is taken off for further reduction for the feed and the fast motion drive. This is described in section 4.10. The motor, fig.4.1 is mounted on a platform pivoted on the tray and situated at the rear of the main drive housing.

The drive to a constant speed pulley shaft in the main drive housing is by vee belts. To adjust the belt tension the motor platform is raised or lowered by means of two adjusting bolts. Fig.4.1 also shows the direction of rotation of the pulleys.

The constant speed pulley shaft drives the "second" shaft through the range change gears, providing an initial high and low speed range. These gears have a neutral position to disconnect the drive for safety purposes when checking motor rotation.

The drive from the "second" shaft is transmitted by spindle speed pick off gears to the centre shaft. A list of gears is given on fig. 4.2. The centre shaft extends along the main drive housing through the hollow centre guide between the main drive and spindle drum housings and through the centre of the spindle drum to a gear on the rear face of the spindle drum.

Access to the speed pick off gears is at the motor end of the main drive housing. Gear changing is described in the Operators Handbook. Standard attachments are driven from the centre shaft to keep a direct speed relationship with the spindle. The gears and the chain wheels required are supplied fitted. The initial drive for the feed gearing is taken from the centre shaft, so that tool feed for each spindle revolution remains constant with any change of spindle speed, and the overall cycle time will vary with spindle speed changes.

Drives requiring constant speed are taken from the constant speed pulley shaft. These are the fast motion drive, coolant pump drive and the lubrication oil pump drive. All the chain drives and the position of the chain wheels can be seen on fig.4.2. All the chain drives, with the exception of the oil pump drive, are provided with jockey sprockets to tension the chains. The oil pump is mounted on a swinging bracket and chain tension is adjusted by moving this bracket. The chain drives are illustrated with directions for adjustment on fig.4.3

Do not overtighten chains. Correct adjustment should allow the middle of the longer run of any one chain to be moved sideways a minimum of 3/4in (19mm).

Fig.4.1

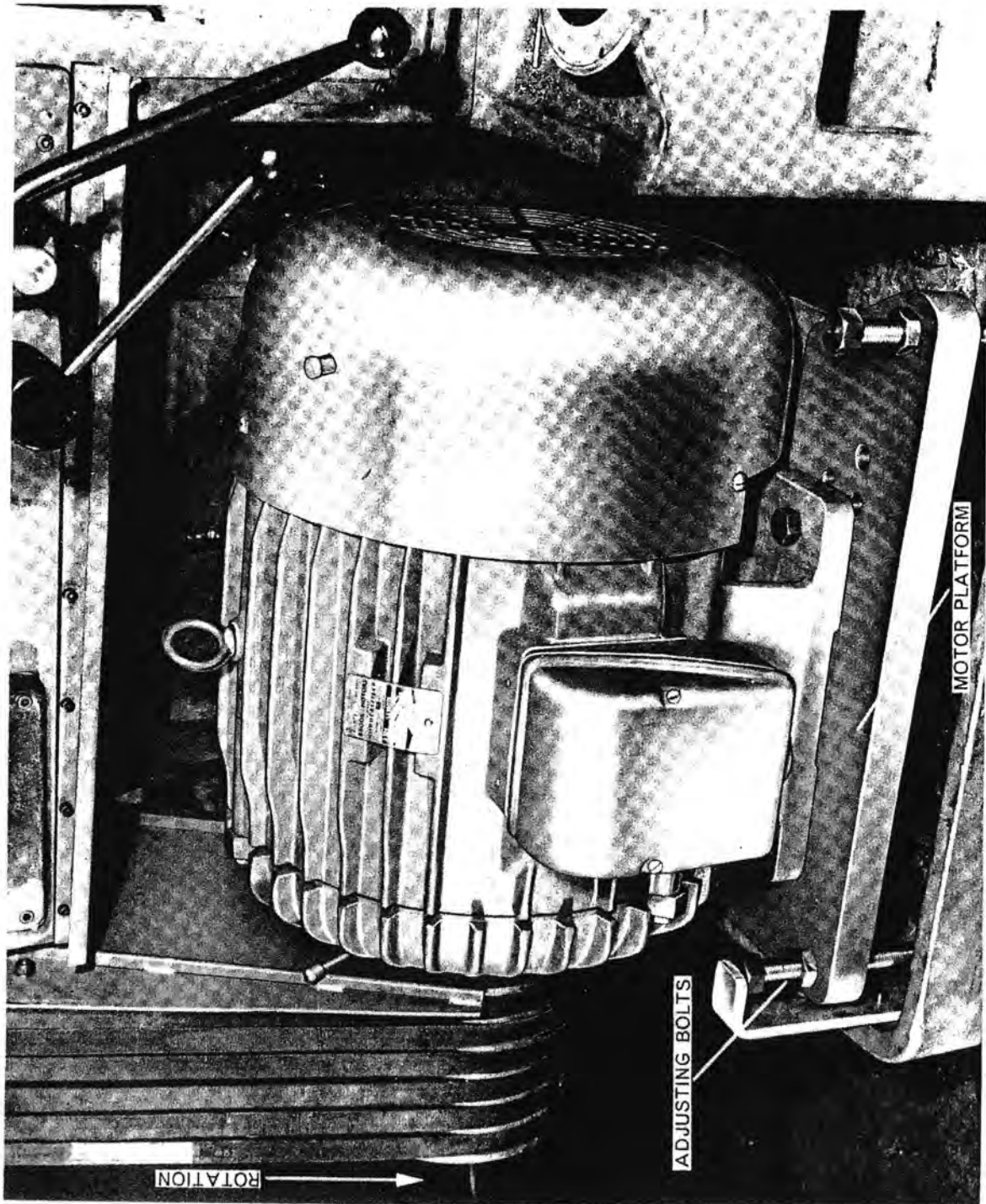
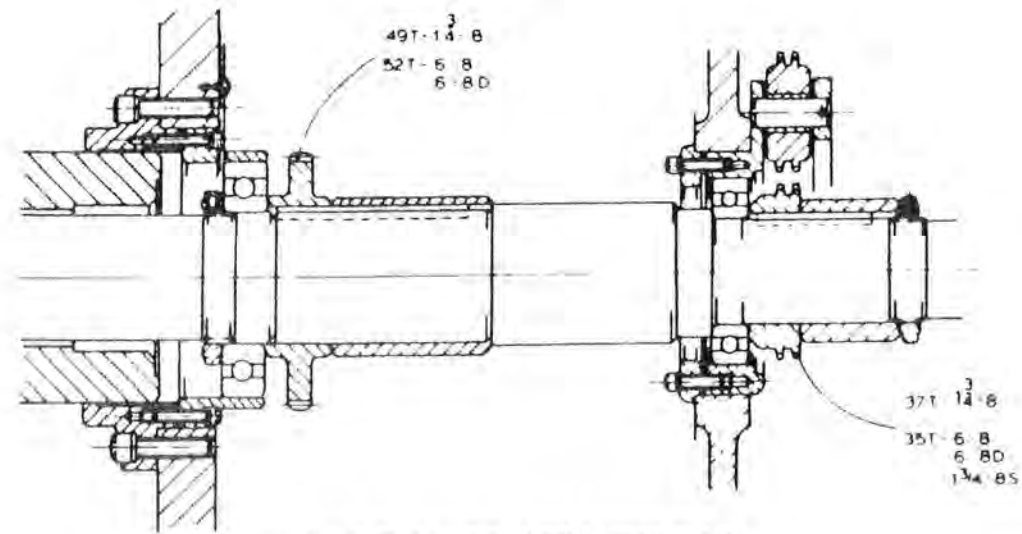
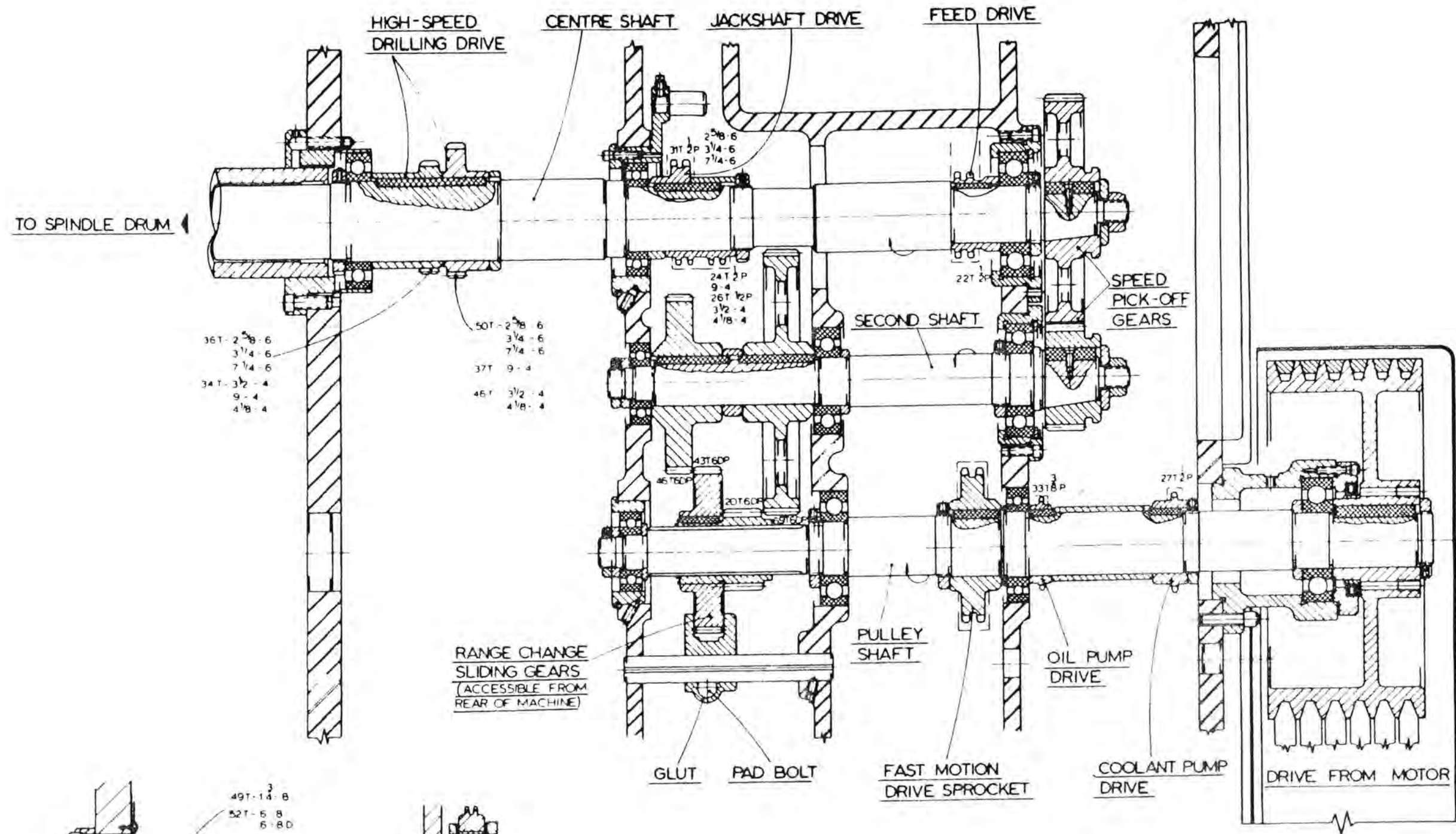

Fig.4.2



CENTRE SHAFT ARRANGEMENT
FOR 1 3/4-8, 6-8 & 6-80

FM SPROCKET	MACHINE SIZE	MOTOR R.P.M.
32T 5/8P	2 3/8-6	1450
	1 3/4-8	
	6-8	
	7 1/4-6	
23T 5/8P	6-8	960
	6-80	
	3 1/4-6	
	3 1/2-4	
	4 1/8-4	
	9-4	
23T 5/8P	7 1/4-6	1450
	7 1/4-80	
	6-80	
23T 5/8P	7 1/4-60	960
	7 1/4-80	

LIST OF SPEED GEARS 'A' AND 'B'	
No OF TEETH	DRAWING No
22	517 Y 159
24	517 Y 160
27	517 Y 161
30	517 Y 162
32	517 Y 163
35	517 Y 164
37	517 Y 165
40	517 Y 166
42	517 Y 167
45	517 Y 168
47	517 Y 169
50	517 Y 170
52	517 Y 171
55	517 Y 172
57	517 Y 173
60	517 Y 174
63	517 Y 175
65	517 Y 176

Fig.4.3

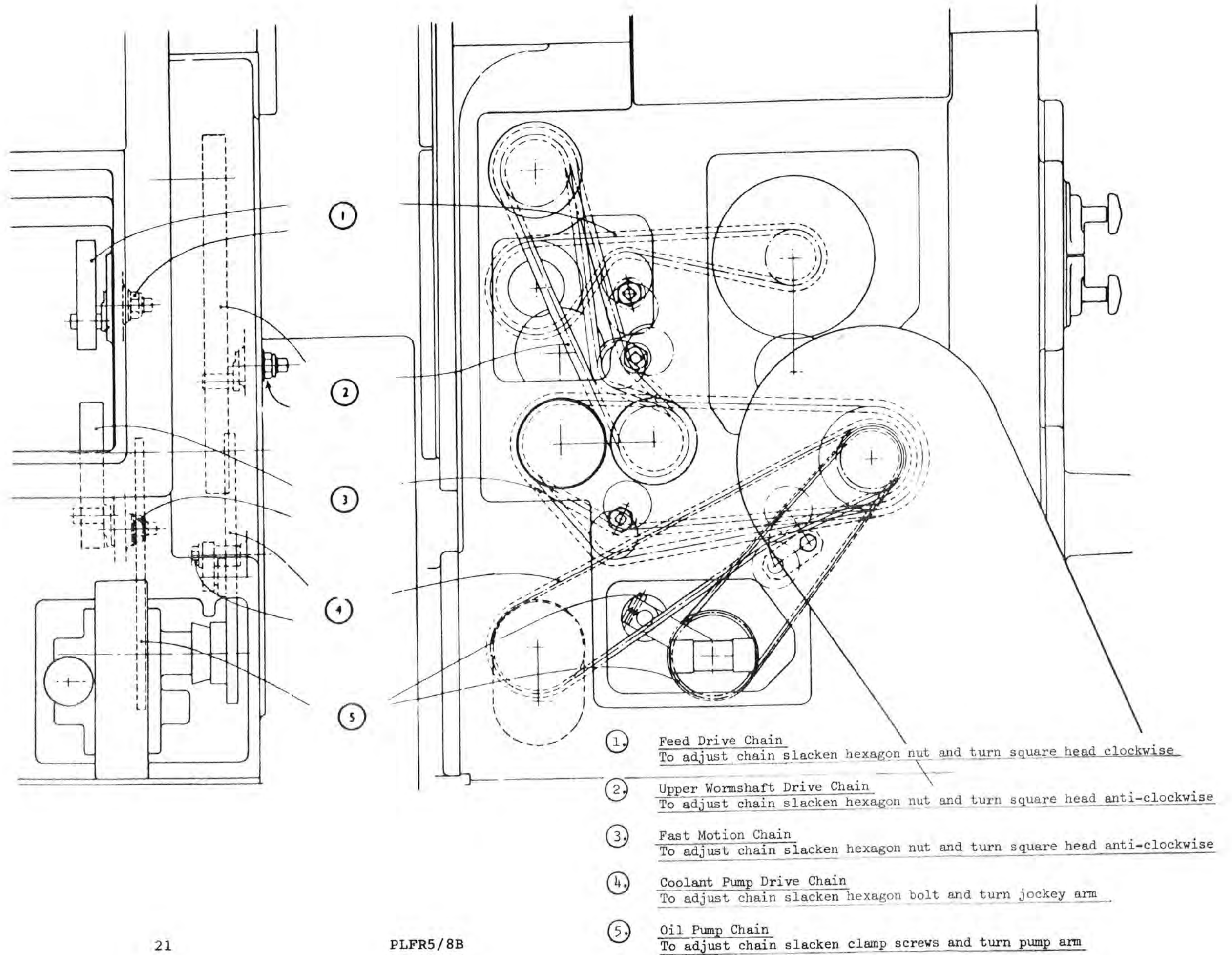
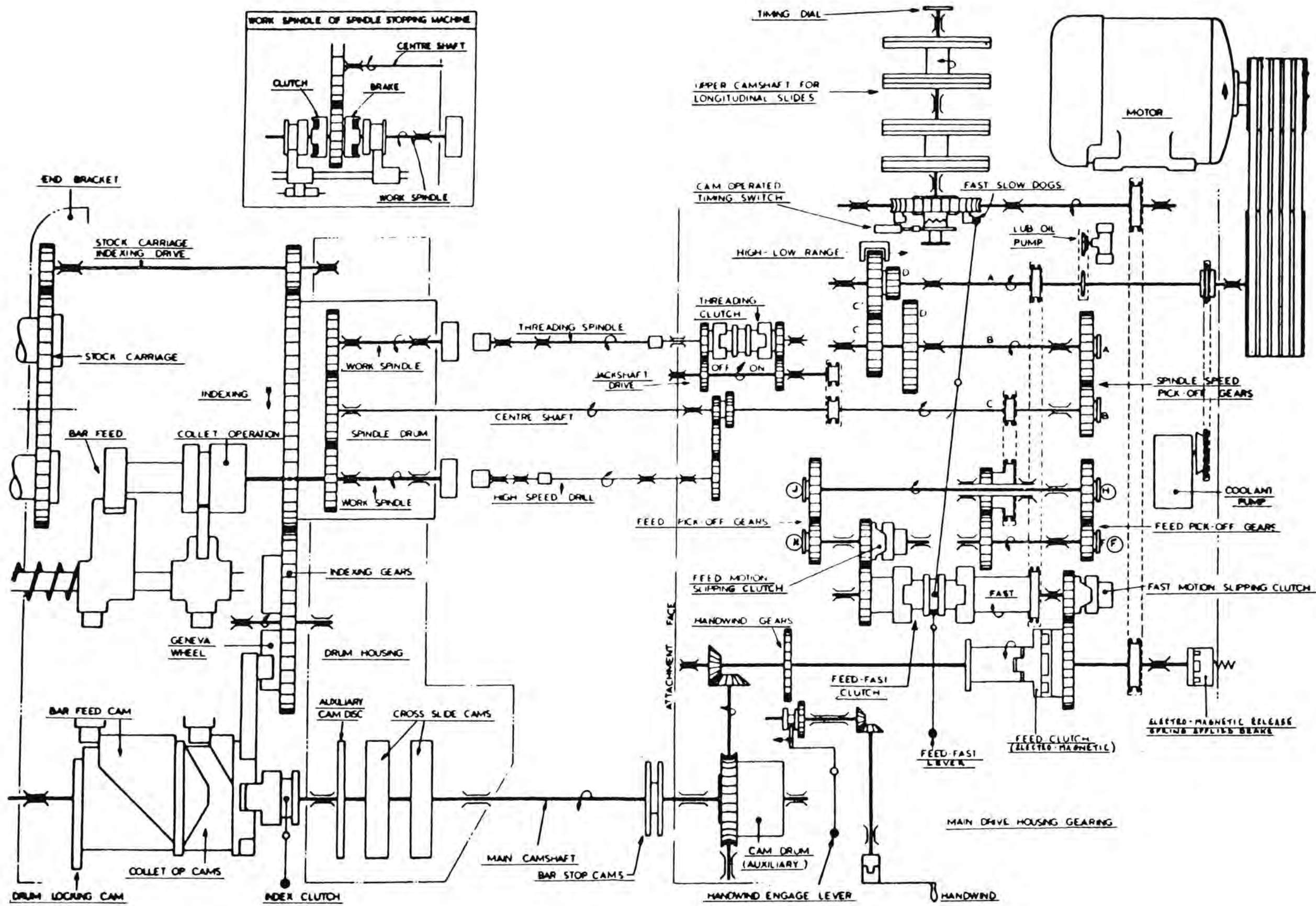

Fig.4.4



4.2 Spindle Drum

The drive from the motor was described to the point where the centre shaft passes through the hollow centre guide to the spindle drum.

Fig.4.5 illustrates this end of the centre shaft, with the spindle drive gear keyed to it and the driven gears mounted directly on each work spindle.

The spindle gears on the 1.3/4"-8 spindle machine are alternately staggered. Spindles 1,3,5 and 7 being arranged with their gears in the inside position. On the 1.3/4"-8S (spindle stopper) and the 50mm-8 machines, the spindle gears are not staggered.

The spindle drum carries the work spindles and the centre guide on which the main tool block slides. This arrangement ensures consistent alignment of the work spindles with the main tool block. The end thrust of the tools upon the spindle drum is taken by the stop ring secured to the front of the spindle drum. This stop ring also carries stop screws which are adjustable dead stops for the innermost position of the cross slides, giving independent setting between each cross slide and spindle in each indexed station.

Hardened steel thrust pads are fitted in the rear flange of the spindle drum to eliminate end float and are adjusted by screws and locknuts. These should be set with no clearance between the pad and the drum housing face when drum is cold.

The drum is supported at both ends in machined diameters in the drum housing. A gear on the rear (bar feed end) of the drum, is driven through a gear train by the Geneva gear, and relays the motion of the Geneva mechanism to the drum to index the drum through 45 degrees. A further gear is taken from the drum indexing gear to drive the indexing of the stock carriage. See fig.4.6.

Fig. 4.5

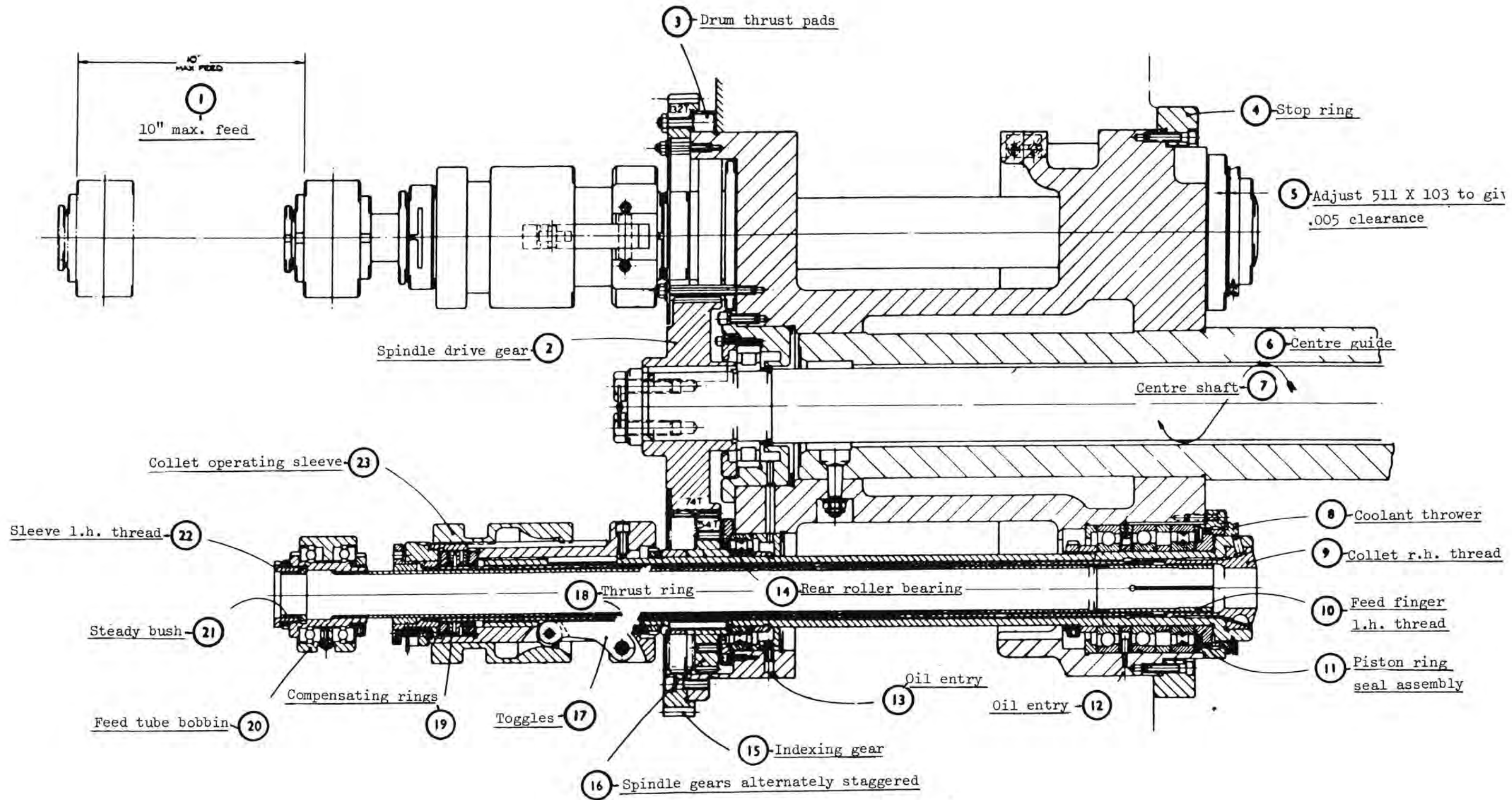
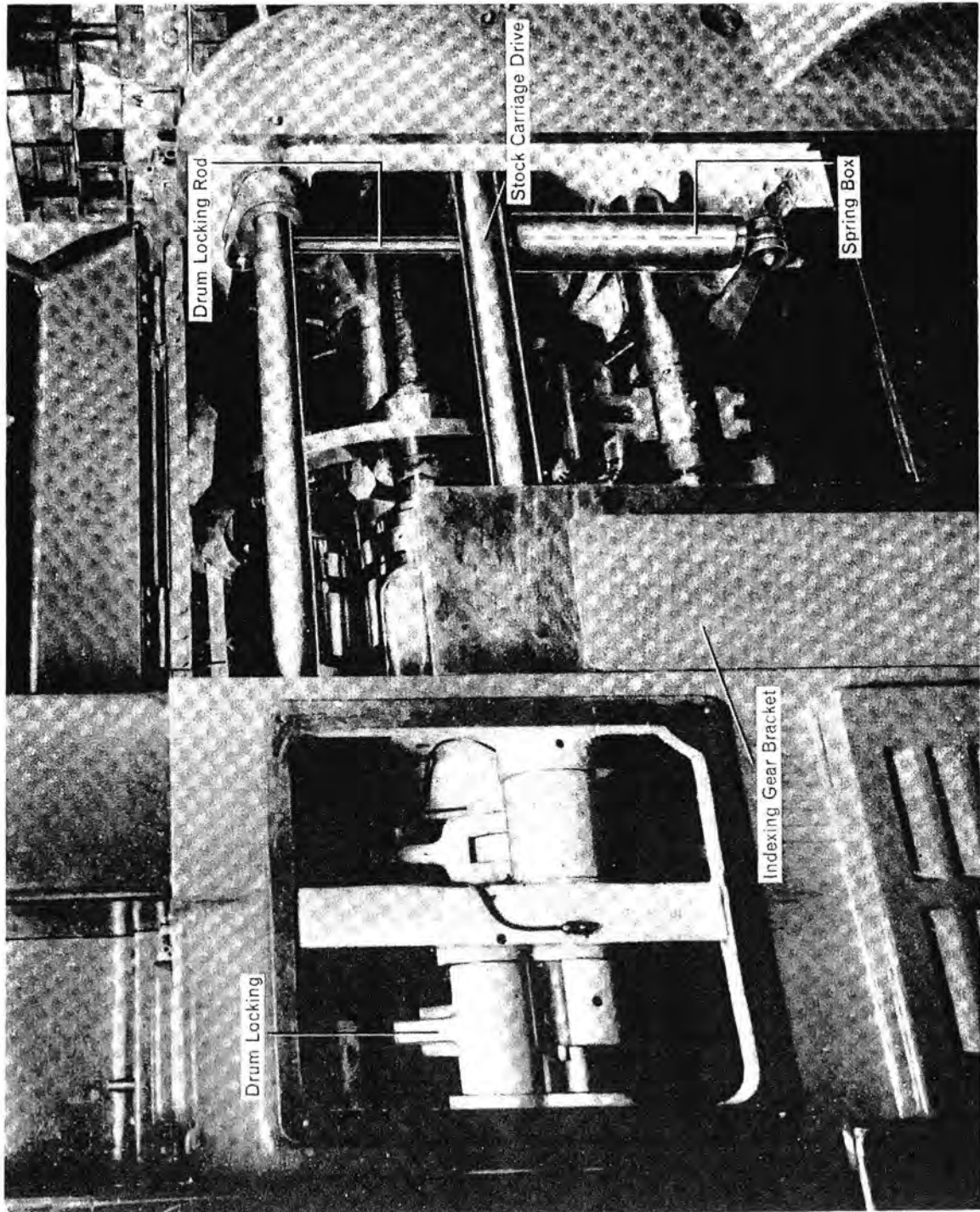

Fig.4.6



4.3 Workspindles for the 1.3/4"-8 Spindle Machine

The work spindles are supported at the front in a set of extra precision bearings comprising a parallel roller bearing nearest to the spindle nose and a pair of preloaded angular contact bearings. An extra precision roller bearing supports the rear of the spindle.

The front bearings are protected against the ingress of coolant and swarf by a piston ring seal and labyrinth and by a coolant thrower mounted on the spindle nose. The front bearing end cap is provided with a grease nipple so that the seal assembly can be filled with grease to exclude foreign matter. Inspection of the seal assembly can be made by removing the coolant thrower and the end cap.

The front and rear bearings are lubricated in the 5th and 6th stations by oil from a pressure header on the beam above the drum housing. Slight drip feeds mounted on the beam are provided for checking the flow. Spacing rings on the spindle assembly retain the lubricant to a suitable level and drilled passages in the drum allow internal oil flow around the front bearing assembly.

4.4 Front Bearing End Float, Collets and Collet Adjustment and Feed Tube Removal

The Timken taper roller bearings are adjusted by a slotted lock nut accessible by removing the front upper cover on the drum housing. The slotted lock nut is split and clamped by a cap screw. The cap screw should be kept lightly clamped whilst adjusting the bearings. The following procedure is recommended when checking and adjusting:-

- a) Check end float with a clock indicator (preferably a magnetic base type) mounted on the spindle drum and feeling against the spindle.
- b) Check with bar gripped in the collet.
- c) Use a short lever to exert pressure on the spindle, pushing the spindle the extent of the end float to obtain a reading.
- d) The end float should be very gradually reduced by adjusting the locknut with short sharp taps on a wrench or a broad punch located in the slotted locknut. Remember, actual nut movement should be small, a 1/16in(1.5mm) turn on the outside of the nut will reduce the end float approximately 0.00017in(0.004mm). An end float of 0.0006 to 0.0008in(0.015 to 0.020mm) should be set for normal speeds.
- e) The end float can be increased to 0.0008 to 0.0010in(0.020 to 0.025mm) for high speeds.
- f) The cap screw in the slotted locknut should be tightened after each adjustment before reading the end float and only slackened sufficiently to allow the nut to turn when adjusting.
- g) After each adjustment, before reading the value of the end float, the spindles should be jogged to settle the rollers.
- h) When over-adjustment reduces end float below 0.0006in(0.015mm) it is necessary, after turning the slotted locknut back, to separate the bearings a small amount by mallet blows on the rear (bar feed end) of the spindle. By this means it is possible to jolt the front bearing and the piston ring carrier away from the spindle shoulder so that mallet blows struck in the opposite direction re-seats the front bearing and piston ring carrier against the spindle shoulder. This procedure ensures that the correct end float reading is obtained and if not fully applied it may give a false reading which will increase under operating load as the bearings re-seat.
- j) When adjusted satisfactorily run the machine at about 150 r.p.m. gradually increasing to the spindle speed required, observing the temperature at regular intervals on a thermometer placed in an end cap screw hole. Temperature should not exceed shop temperature, + 70 degrees F (21 degrees C) at approximately 400 r.p.m.

The following information applies if spindles and bearings are dismantled from the drum:-

- a) Check that the oil feed and circulation holes are clear.
- b) Assemble bearings on the spindle with the biggest bore for the adjustable bearing nearest to the locknut. This makes the end float adjustment easier.

- c) Eccentric marks on the outer races to be in line and radially outwards.
- d) Eccentric marks on the inner races to be in line.
- e) The front bearing and piston ring carrier to be pressed hard against the spindle shoulder.

The tension on the collet is adjusted by means of the collet adjusting sleeve, and after fitting new collets, must always be tested by hand before running under power.

When adjusting the collet tension, extra clearance for the spanner (item No. 573X106) may be obtained by placing a spacing block (item No. 573X113) between the stop collar on the front guide rod and the bar feed slide, see fig.4.6. The spacing block should be placed into position when the bar feed slide withdraws.

The feed fingers are fitted to feed tubes carrying on their outer ends the bar feed bobbins mounted on anti-friction bearings. In order to remove the feed fingers it is first necessary to slide back the stock carriage tubes. These are held in the stock carriage indexing gear by clamps which must be slackened and turned clear to release the stock carriage tubes. By turning the plate on the rear of the centre stop the feed tubes may be removed from the machine complete.

Bar steady bushes are fitted in the end of the feed tubes and are retained by a screwed sleeve and slotted locknut.

Collets are of the draw back type and are opened and closed by a toggle mechanism on the rear end of the spindles and a spring compensator is included to accommodate small variations in bar size. The collet may be removed from the spindle by releasing the spring plunger and turning the collet adjusting sleeve until the collet is screwed clear.

The tension on the collet is adjusted by means of the collet adjusting sleeve, and after fitting new collets, must always be tested by hand before running under power.

When adjusting the collet tension, extra clearance for the spanner (item No. 573X106) may be obtained by placing a spacing block (item No. 573X113) between the stop collar on the front guide rod and the bar feed slide, see fig.4.7. The spacing block should be placed into position when the bar feed slide withdraws.

The feed fingers are fitted to feed tubes carrying on their outer ends the bar feed bobbins mounted on anti-friction bearings. In order to remove the feed fingers it is first necessary to slide back the stock carriage tubes. These are held in the stock carriage indexing gear by clamps which must be slackened and turned clear to release the stock carriage tubes. By turning the plate on the rear of the centre stop the feed tubes may be removed from the machine complete.

In order to extract the feed tube in station 1 it is necessary to withdraw the bar feed shoe. The machines are fitted with a screwed knob which can be pulled down to withdraw the shoe or turned to retain it in the withdrawn position. Bar steady bushes are fitted in the end of the feed tubes and are retained by a screwed sleeve and slotted locknut.

Fig.4.7

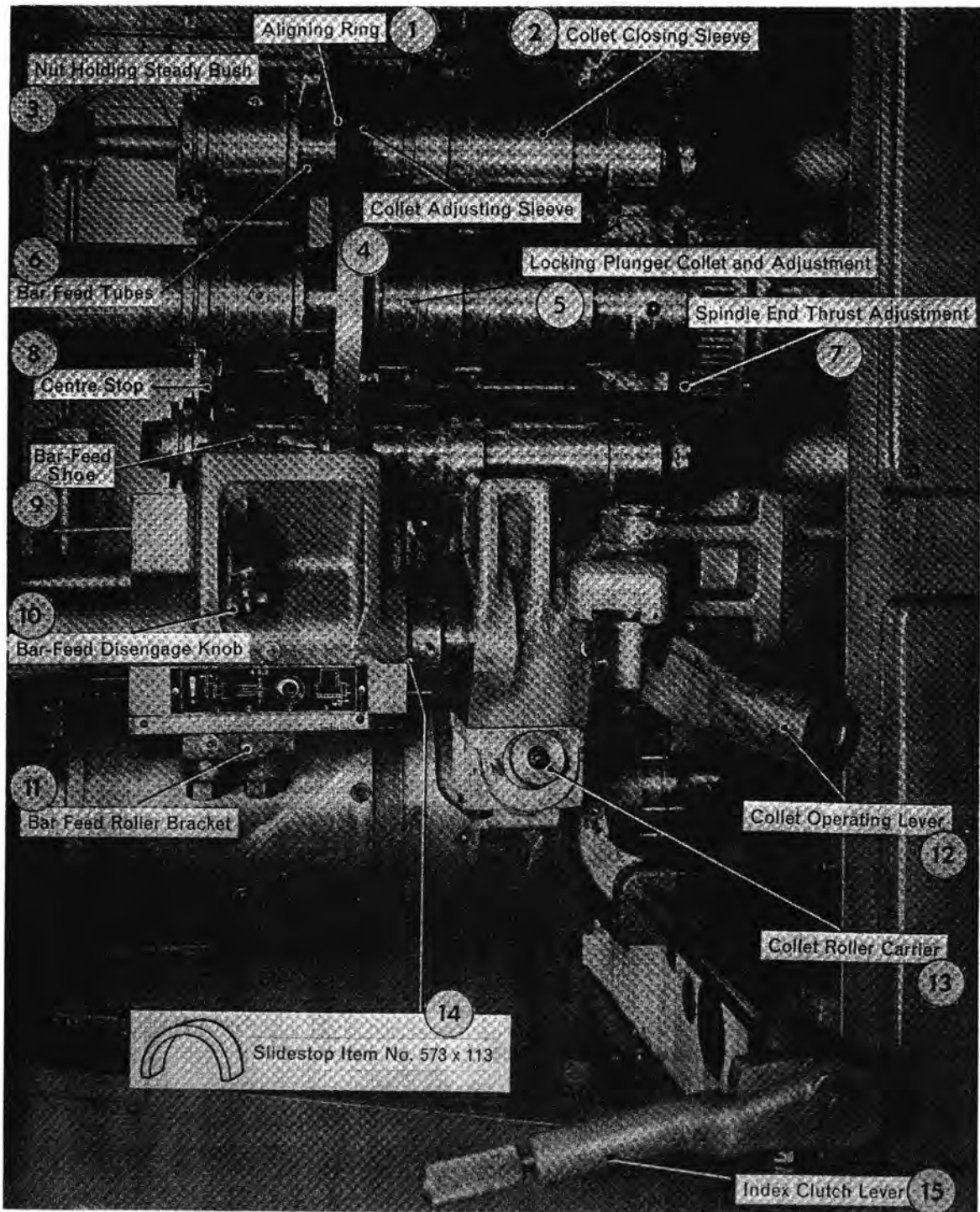

4.5 Workspindles 1.3/4"-8S (arranged for spindle stopping)

The spindle stopper version of the 1.3/4"-8 machine enables spindles to be stopped in stations and held in stations 3,4,5,6 and 7. All combinations of stopping and starting can be arranged between these stations.

Standard machines cannot be converted to a spindle stopper and provision must be made at an early stage of manufacture.

Fig. 4.8 shows the spindle drum assembly; each spindle gear is driven from the central gear and runs loosely on ball bearings when the multi-plate brake is engaged. The brake contains a series of preloaded cushion springs which limit and maintain the brake torque and is sufficient to brake the spindles to a standstill.

The multi-plate drive clutch on each spindle is engaged by the axial thrust imparted by a row of balls, squeezed inwards against conical and flat faces by the clutch bobbin when it is moved by the cam operated clutch glut. The clutch is adjusted by turning the slotted nut from serration to serration on its right hand thread, the serrations being maintained in engagement by a series of clutch plate separation springs. The clutch is accessible for adjustment in the 8th station and an adjustment of one serration at a time can be made by a sharp hammer blow on the clutch punch 573X115. After adjustment the clutch must be checked using the hand lever 502X251 and a spring balance reading between 50 and 70lb (22.73 and 31.8 kgs) measured at the knob end of the lever should be maintained.

The clutch gluts are operated during indexing of the spindle drum by a series of cams secured in housings at the bar feed end of the drum housing. The cams may be selected to suit varying tooling requirements and are supplied to order. One cam housing is supplied as standard:- Cams are supplied to stop in stations ordered by the customer.

When fitting new cams handwind through index to ensure that the rollers pass freely all round the cam track.

Cross slide attachments and drives for use with spindle stopping machines are usually designed for a special and limited application to suit customer's components.

Fig.4.8

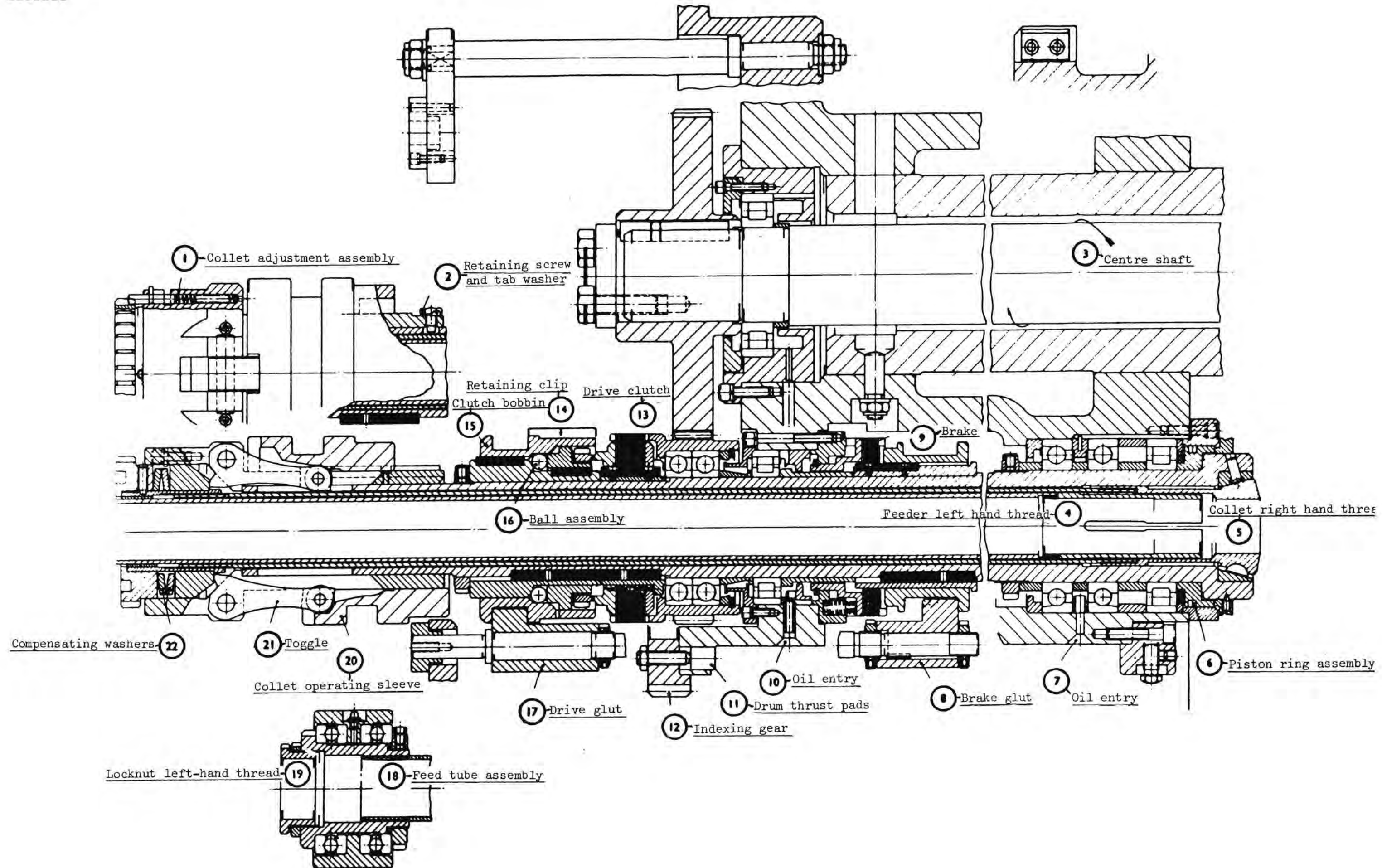

4.6 Dismantling (1.3/4"-8S Machine)

It is recommended that spindle removal be undertaken by Wickman Bennett Service Engineers who are fully trained and highly skilled in machine reconditioning.

A brief guide to the procedure is given below:-

The drive clutch and brake clutch gluts and operating shaft should be first removed, preferably in the 8th station. Unscrew the drive clutchglut retaining nut and the end nut at the brake glut (accessible through the drum housing). Withdraw the shaft through the gluts sufficiently to remove the key in the shaft at the brake glut end. Dismantle the shaft bearing at the drive glut end and withdraw the shaft, graduallu unscrewing the remaining nuts.

Remove the feed tube. Remove the cap screw and retaining washer from the end of the toggle carrier and withdraw the collet tube assembly. Remove the hexagon head screw (secured by a tab washer) from the toggle carrier and withdraw the toggle carrier assembly. Remove the spindle locknut and withdraw the drive clutch assembly. The shape shown as --- 2.3/16" --- , fitted over the operating sleeve will hold the ball thrust ring and retain the 24 operating balls.

Drive clutch plates can then be stripped. Unscrew the front bearing ad justing nut from the spindle. Dismantle the spindle nose thrower ring (where fitted) and the front cap covering the piston ring seal.

The spindle may then be withdrawn, stripping the drive gear and bearings, the rear bearing spacer, brake plates and operating sleeve and the front bearing nut and spacer, leaving in the drum the rear roller bearing and spacer and the brake spring assembly. The front bearings and spacers should withdraw with the spindle.

The rear roller bearing and its spacer are retained by an end cover and the brake housing which is clamped by cap screws through the drum.

Replace the spindle and its component assemblies in the reverse order to dismantling, ensuring correct order of replacement as the spindle is fed through the bearings. Other adjustments are as follows:-

Hold the glut shaft in the brake position by screw and collar in the end of the glut shaft and adjust the brake glut retaining nut to obtain 3/32in(2.38mm) compression of the brake springs.

The clutch is to be in neutral when tightening the spindle locknut which clamps the ball assembly.

4.7 Workspindles for the 50mm-8 Spindle Bar Automatic

The work spindles are supported at the front in a set of extra precision bearings comprising a parallel roller bearing nearest the spindle nose and a pair of preloaded angular contact bearings. An extra precision pair of deep groove ball journal bearings support the rear of the spindle.

The front bearings are protected against the ingress of coolant and swarf by a piston ring seal and labyrinth and a coolant thrower mounted on the spindle nose. The front bearing end cap is provided with a grease nipple so that the seal assembly can be filled with grease to exclude foreign matter. Inspection of the seal assembly can be made by removing the coolant thrower and the end cap.

The front and rear bearings are lubricated in the 5th and 6th stations by oil from a pressure header on the beam above the drum housing. Sight drip feeds mounted on the beam are provided for checking the flow. Spacing rings on the spindle assembly retain the lubricant to a suitable level and drilled passages in the drum allow internal oil flow around the front bearing assembly.

Collets are the draw back type and are opened and closed by a toggle mechanism on the rear end of the spindles and a spring compensator is included to accommodate small variations in bar size. The collet may be removed from the spindle by releasing the spring plunger and turning the collet adjusting sleeve until the collet is screwed clear.

The tension on the collet is adjusted by means of the collet adjusting sleeve, and after fitting new collets, must always be tested by hand before running under power.

When adjusting the collet tension, extra clearance for the spanner (item No 573X106) may be obtained by placing a spacing block (item No 573X113) between the stop collar on the front guide rod and the bar feed slide, see fig 4.7. The spacing block is provided in the tool kit and should be placed into position when the bar feed slide withdraws immediately before indexing commences.

The feed fingers are fitted to the feed tubes, carrying on their outer ends, the bar feed tube bobbins mounted on antifriction bearings. In order to remove the feed fingers it is first necessary to slide back the stock carriage tubes. by turning the plate on the rear of the centre stop the feed tubes may be removed from the machine complete. Bar steady bushes are fitted in the end of the feed tubes and are retained by a screwed sleeve and slotted locknut.

4.8 Collet Operation and Bar Feed

After the workpiece is cut off in 8th station the machine is indexed to the 1st station, the collet opened, bar stock fed out to the bar stop and the collet closed just before the advancing tools start cutting; see timing diagram fig. 4.44 in the 'Operator's Handbook'.

The collet operation mechanism consists of a cam operated slide moving on two round guide bars mounted between the drum housing and the end bracket.

A bonded fabric shoe carried in a slot in the slide engages in a groove in the collet sleeve on the work spindle. It is spring loaded so that if a collet sleeve indexes out of position the shoe will be depressed and rendered inoperative.

The collet slide is operated by a roller and barrel cam direct from the main camshaft and can be disengaged by loosening a pad bolt and pulling the roller carrier outwards clear of the cams. Adjustable nuts carried on a rod provide a stop for the operating slide and enable the mechanism to close the collets to a constant position, with either hand or cam operation. Fig.4.9 shows the correct adjustment for these nuts.

The bar feed mechanism is spring operated and controlled by a barrel cam on the main camshaft. The slide is mounted, as the collet operation slide, on the two guide bars and carries an aligning ring and a spring loaded shoe. The aligning ring encircles all the bar feed tubes and in the 1st station restrains the feed tube bobbin between the ring and the spring loaded shoe. The spring loaded motion of the slide and the shoe feeds the bar feed tube and the bar through the collet tube to the bar stop. On the return cam stroke the aligning ring returns the feed tube to a "ready to be fed" position and holds it there, together with the other bar feed tubes. Any endwise movement of the tubes is limited by the aligning ring and the adjustable centre stop, carried on a shaft extension on the stock carriage and centrally placed between all the spindles, see fig.4.9.

Two cams are needed to cover the bar feed stroke range; a 1/2in to 5in (12.7 to 127mm) cam is supplied as standard and a 5in to 10in (127 to 254mm) cam, 544Y106B is available to order.

For the 1.3/4"-8 machine only, two cams are available. The cam supplied as standard covers a range of 1/2in to 5in (12.7 to 127mm) and a 1.1/4in to 6.1/4in (32 to 159mm) cam, 502V258 is available to order.

On the 1.3/4"-8S machine only, the 1/2in to 5in (12.7 to 127mm) cam is supplied as standard, and a 1.1/4in to 6.1/4in (31.7 to 158.7mm) cam, No502 V 258 is supplied to order.

Collet tension and bar feed stroke adjustment is described under operating adjustments, in the 'Operator's Handbook'.

The machines are fitted with a limit switch operated by a rod and an adjustable clamp from the bar feed side. The function and the setting of this mechanism is covered under Auto-Stop Mechanism. See section 4.20.

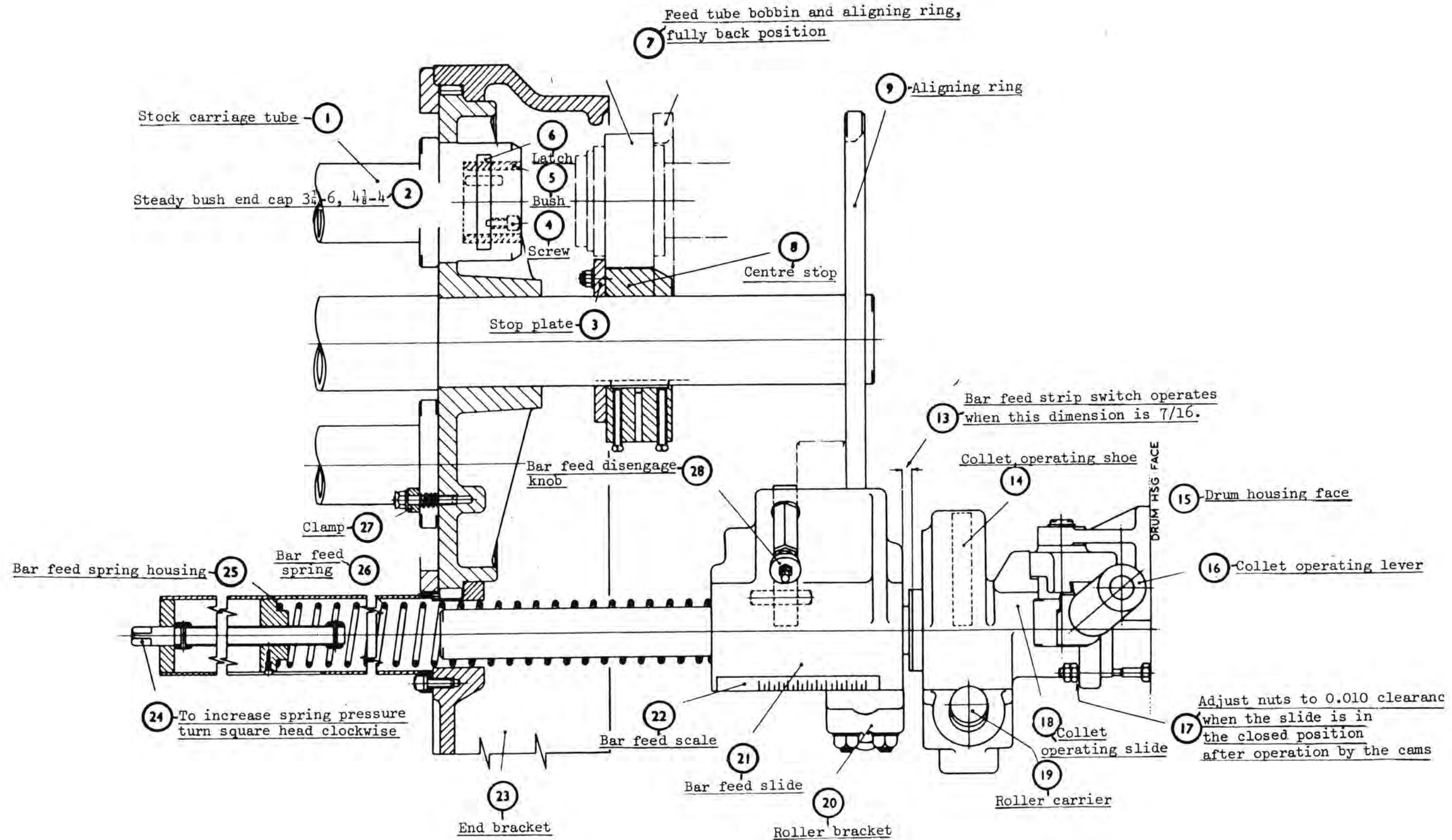

4.9 Indexing and Drum Locking

The spindle drum is indexed anti-clockwise (looking on the collets) by gearing from the Geneva wheel. The mechanism is mounted at the rear of the machine on the bar feed end of the drum housing, and is shown diagrammatically on fig. 4.10. The four slot Geneva wheel and gear is driven by the passage through one of the slots of a roller carried on an arm mounted on the bar feed cam drum. During each fast motion cycle the drum is unlocked and indexed to the next station, 0.050in (1.27mm) past the final position. This allows a spring loaded latch in the spindle drumhousing to drop into position before the drum is clamped back against the latch and locator pads on the drum locking mechanism.

The latch, which is accessible through the front upper cover, should be adjusted with the latch sitting on the locator pad to give 1/32in to 1/16in (0.8 to 1.6mm) clearance to the nuts, as shown on fig.4.11.

The drum locking mechanism, accessible through the rear upper cover, is essentially a toggle mechanism arranged to lock the spindle very near to the dead centre position of the toggle.

The toggle pivots on a shaft with eccentric adjustment to obtain the correct clamping pressure and a stop screw in the drum housing is set 0.010in (0.25mm) clear of the toggle link to give the correct toggle off-set when locked. The following procedure should be followed to test for correct adjustment and should preferably be done when the spindle bearings have reached their normal running temperature:-

Place a tommy bar approximately 12in (304.8mm) long 5/8in (16mm) diameter, in a socket in the upper toggle link (a screwed cover on the top of the drum housing will have to be removed). Disconnect the pin in the operating lever and the long spring box rod situated near the end bracket, fig.4.11. Pull the tommy bar down slowly by hand as far as it will go. The toggle should just bind on the drum and if correct a slight resistance can be felt as the toggle grips when the tommy bar is slowly lifted. The high point of the eccentric is marked on the end of the shaft, visible from the collet end.

The toggle is operated by a link to a lever on the drum locking shaft which is connected to a cam lever by a pre-loaded spring box assembly, fig. 4.12. The long connecting rod should be adjusted to compress the spring 1/8in (3.2mm) when the drum is locked.

Fig.4.10

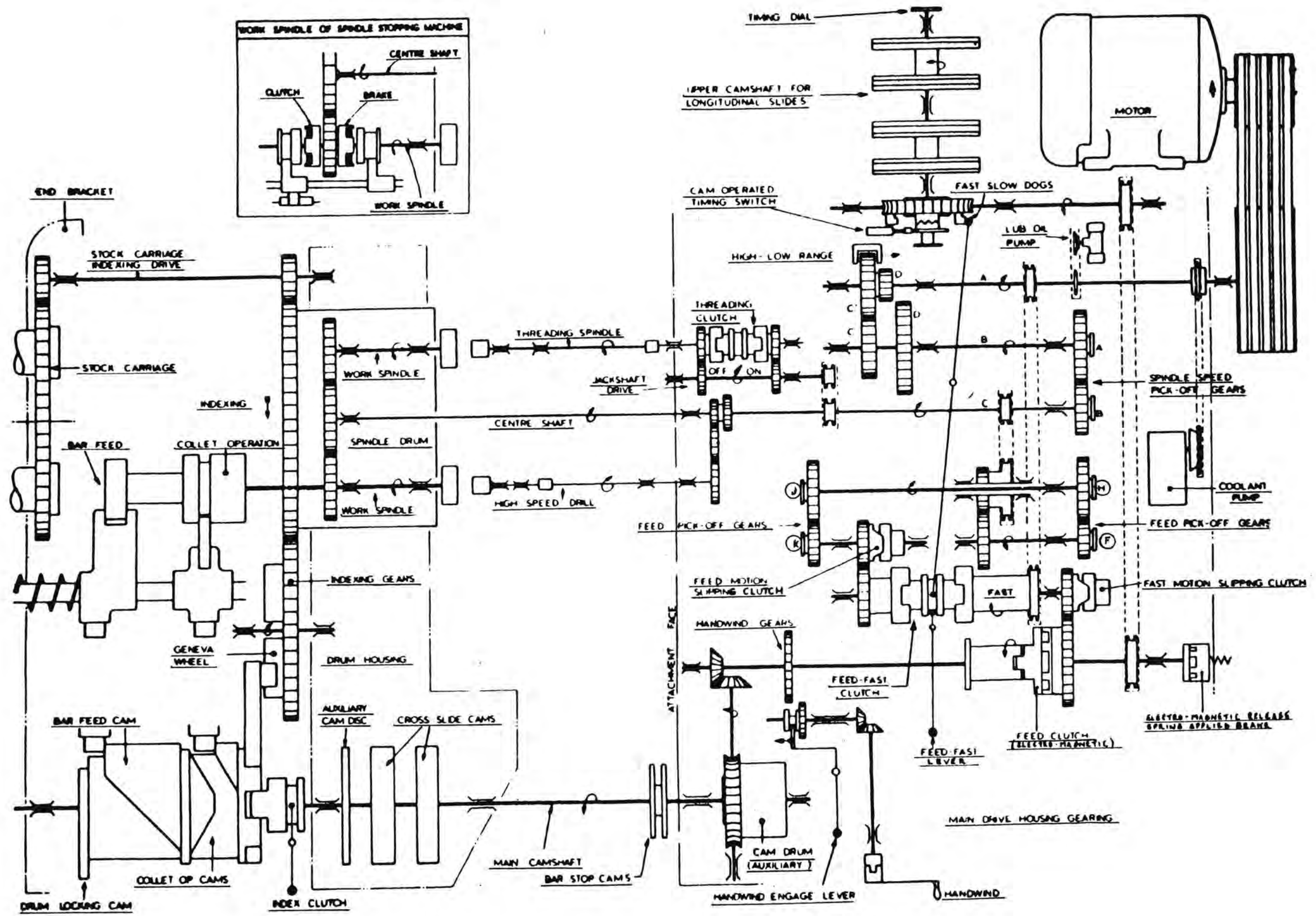

DRUM LOCKING MECHANISM

HOLE FOR TOMMY BAR WHEN TESTING CLAMPING PRESSURE

WHEN SETTING DRUM LOCKING PRESSURE SET PIN OF TOGGLE LEVER WITH HIGH POINT OF ECCENTRIC ON ARC SHOWN

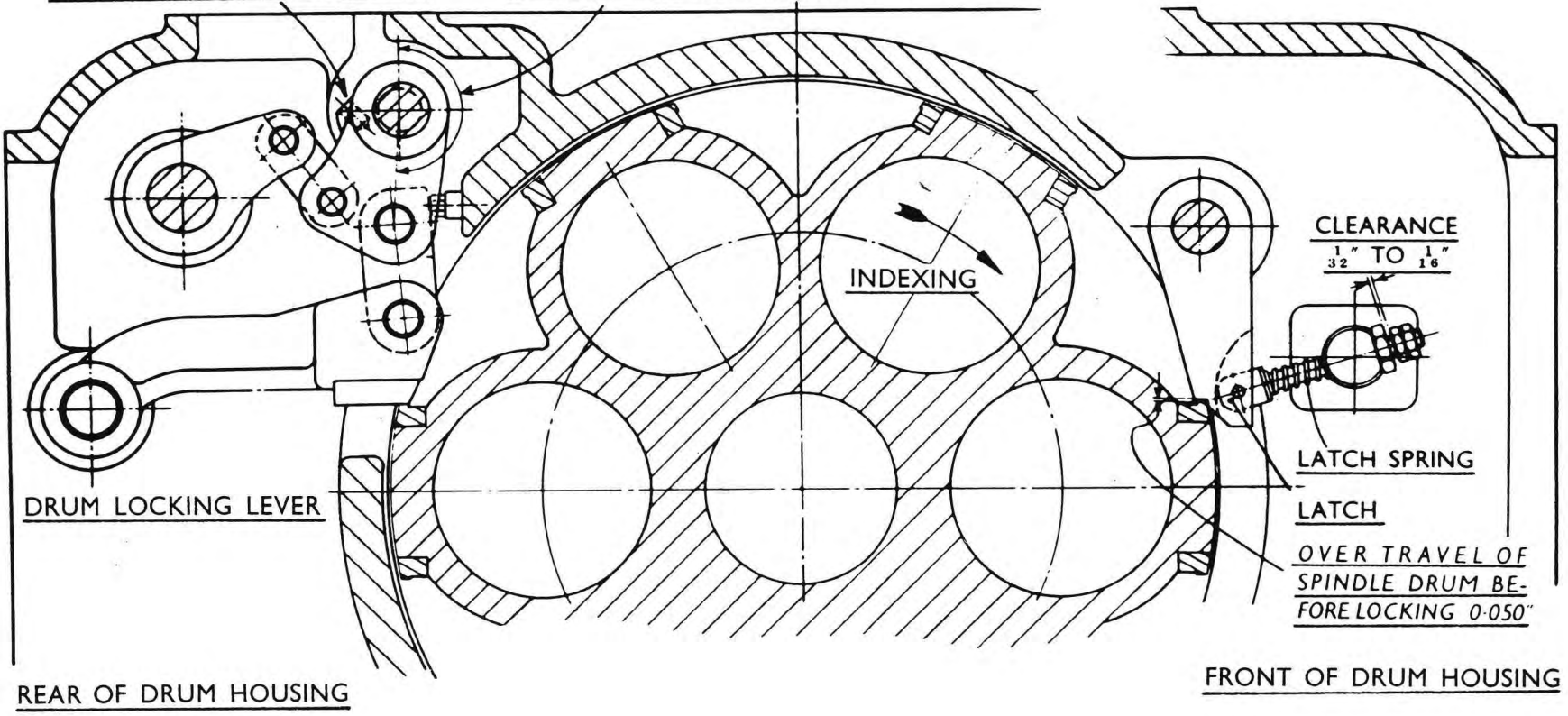

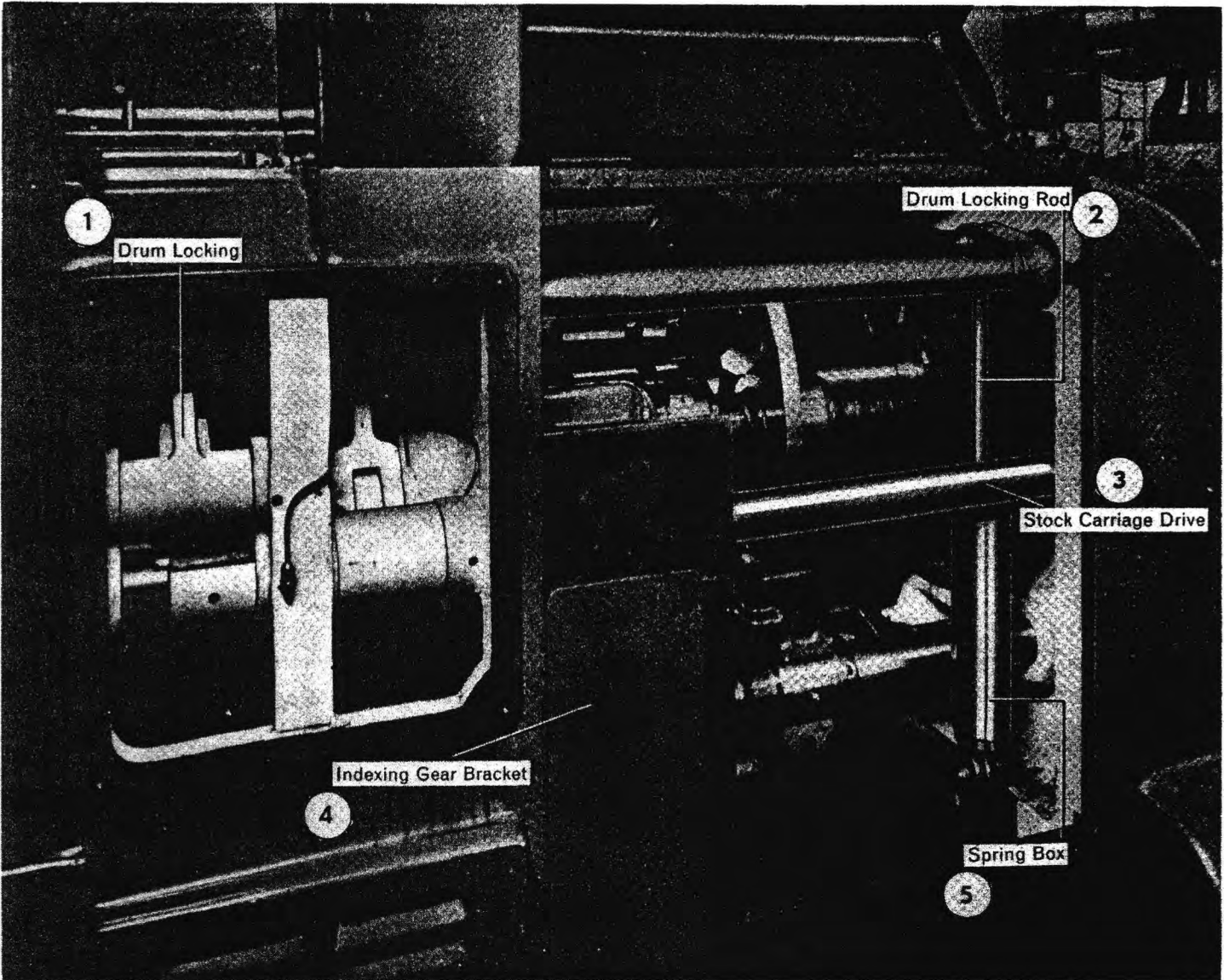

4.10 Feed Drive

The feed drive is transmitted by chain from the centre shaft to a hollow sleeve carrying a gear reduction to the first feed pick off gear shaft; gear "F" on the feed and speed charts. The mating gear "H" is mounted on one end of a shaft with gear "J" on the other end, meshing with gear "K" on the final pick off gear shaft. See fig. 4.13.

The final pick off gear shaft carries the feed overload slipping clutch to protect the drive during the feed portion of the cycle. The sideways disengaging action of the spring loaded clutch de-activates the electro-magnetic multi-plate feed clutch and the electro-magnetic multi-plate brake allowing the brake springs to "brake" the feed drive. The main motor then stops. Before the slipping clutch is re-engaged by sliding the driving dogs into mesh, the cause of the overload should be located and corrected. Access to the feed overload slipping clutch is through the cover carrying the speed and feed plate, fig.4.14.

After passing through the feed overload slipping clutch, the feed drive is transmitted by a pair of gears to the feed side of the feed motion-fast motion clutch.

A roller "freewheel" clutch is built into the gear on the feed motion-fast motion clutch shaft in order to maintain the drive whilst the clutch is in neutral when changing from fast to slow or slow to fast. The fast motion drive is taken from the constant speed pulley shaft by chain directly to the fast side of the feed motion-fast motion clutch.

The drive either fast motion or feed motion, then passes through the fast motion slipping clutch, to a pair of gears driving one side of the electro-magnetic multi-plate feed clutch on the final feed shaft. Adjacent to the feed clutch, mounted upon the final feed shaft is the chain drive sprocket for driving the upper longitudinal camshaft worm and wormwheel.

Bearing housing assemblies in the two outer walls and the inner wall of the attachment drive compartment of the main drive housing support the final feed drive shaft. In addition there is further bearing support between the inner wall and the motor drive end wall. The bearing housing at the motor drive end of the main drive housing also provides the means of mounting the electro-magnetic multi-plate brake which is outboard of the main drive housing.

Forward of the intermediate bearing support, the feed drive is transmitted through a dog clutch co-axially mounted upon and keyed to the final feed drive shaft. This dog clutch is spring loaded into engagement with the co-axial sleeve which provides journal support for, and to which is keyed the electro-magnetic feed clutch. The purpose of the dog clutch is to provide the means of disengaging the feed drive when hand winding the machine through its machining cycle.

The tensioning of the upper longitudinal camshaft worm chain drive is achieved by applying torque to an eccentric mounting for the chain tensioning sprocket. Access to the adjustment of the chain tensioning sprocket is from an external face of the main drive housing motor drive end. In order to adjust the chain tension loosen the hexagon clamping nut and apply a torsional load to the square provided on the eccentric mounting for the chain tensioning sprocket. On achieving the correct tension the hexagon clamping nut must be re-tightened.

The drive, either fast or feed, then passes through bevel pinions mounted on the front wall of the attachment drive compartment which drive the worm and wormwheel on the main camshaft, whose cams and mechanisms operate the cross slides, drum indexing and drum locking, collet opening and closing and bar feeding. The final feed shaft also carries the handwind gear which can be engaged by a handwind pinion when the feed and feed brake clutches are disengaged.

The feed-fast clutch is operated by a yoke and a lever from two adjustable dogs in the "T" slot on the upper wormwheel. The timing of the dogs can be set as required, normally shifting the clutch at the start of the feed period and at the end of dwell when the tools have finished cutting. A diagrammatic illustration of the feed motion and fast motion clutch control is shown at fig.4.15.

The electro-magnetic brake on the final feed shaft brakes the drive to camshafts when the electro-magnetic feed clutch is disengaged manually or by the auto stop control trip feed.

Instructions for adjusting mechanical multi-plate clutches are given on plates fixed to the machine. To increase the driving power of a clutch, rotate the spring ring around the adjusting nut and withdraw the locking plunger. Rotate the nut in the direction of the arrow stamped on the nut until the plunger can be engaged in the next hole in the locking plate. Do not adjust more than one hole at a time before testing the clutch. Replace the spring ring.

When testing the feed motion-fast motion clutches on their transmission shaft, the clutch actuating sleeve, when moved from its midway position should first move easily, build up resistance to a maximum just as the plates compress together and then ease slightly as the internal clutch toggles move over their high point. Set the minimum adjustment to obtain this feel without obtaining obvious clutch slip or overheating.

The electro-magnetic feed clutch on the final feed drive shaft is factory set and should require no further adjustment.

The electro-magnetic brake on the final feed shaft should be adjusted as follows:- Remove the cover to obtain access to the brake. Energise the brake. Refer to the diagram mounted on the cover. Release the grub screw (A) in the centring ring (B). Introduce a resetting key (kept in a slot inside the cover) into a radial groove (C) in the centring nut (D) and turn the nut until the key can be smoothly withdrawn. Check the air gap with the brake de-energised using a 1.2mm(0.048in) feeler gauge. Reclamp the grub screw (A) when the correct gap is obtained.

Emergency brake release:- In order to release the brake for handwinding when the electric power is not available, remove two knurled plugs in the cover and remove metric screws from the tapped holes above the instruction plate. Insert screws through the cover holes into holes in the brake body and turn the screws clockwise as far as possible to release the brake. Remove the screws, replace metric screws and plugs before connecting power to the machine.

Slipping Clutches:- These clutches are assembled with the minimum number of springs and plungers necessary to transmit the torque. Spare plungers, springs and screwed plugs are supplied in the equipment kit and can be fitted when required. It is recommended that the number of plungers in use is kept to a minimum to ensure that the clutches will disengage when necessary. Fit extra plungers, etc, in pairs equally spaced around the clutch body.

Fig.4.13

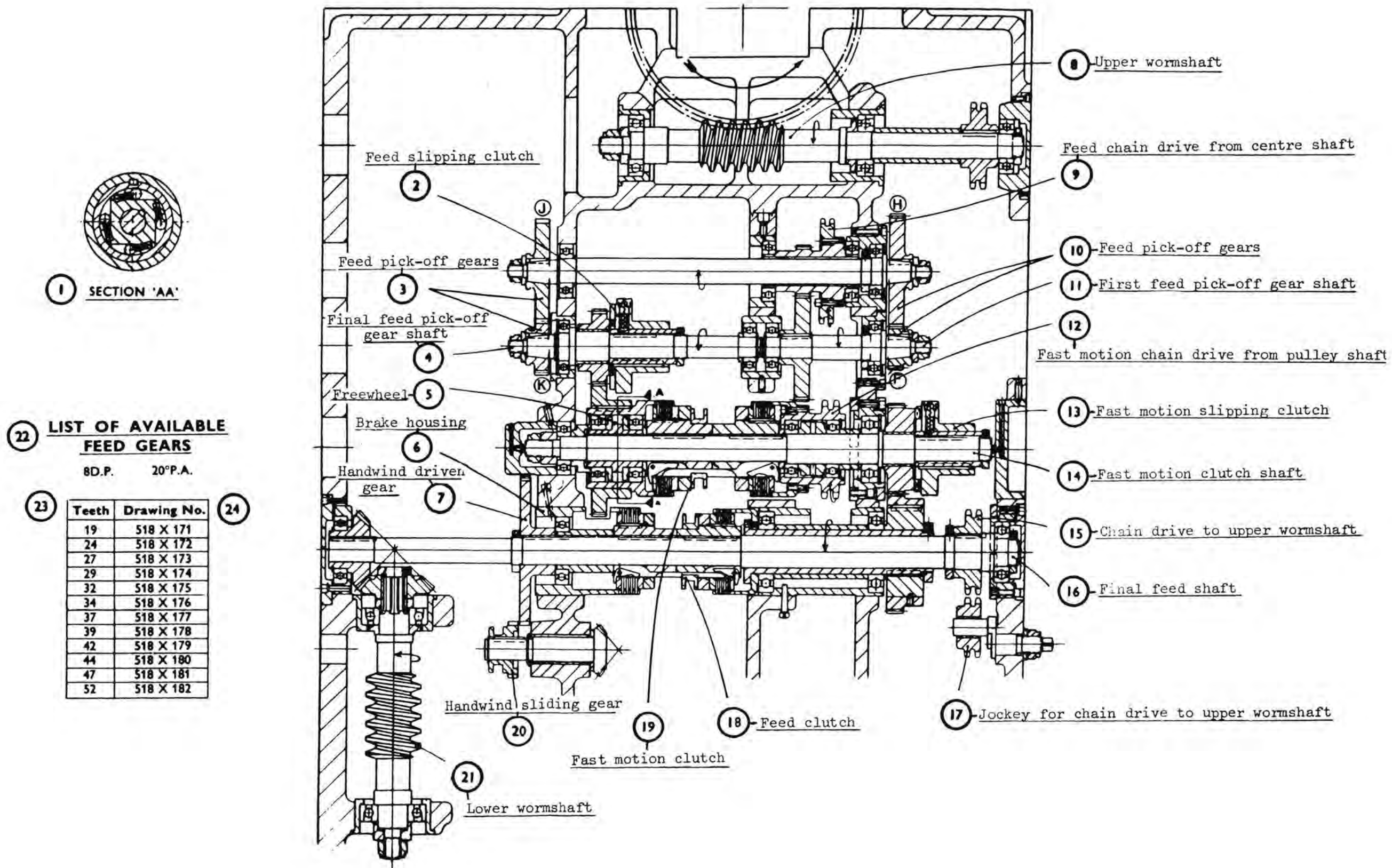

Fig.4.14

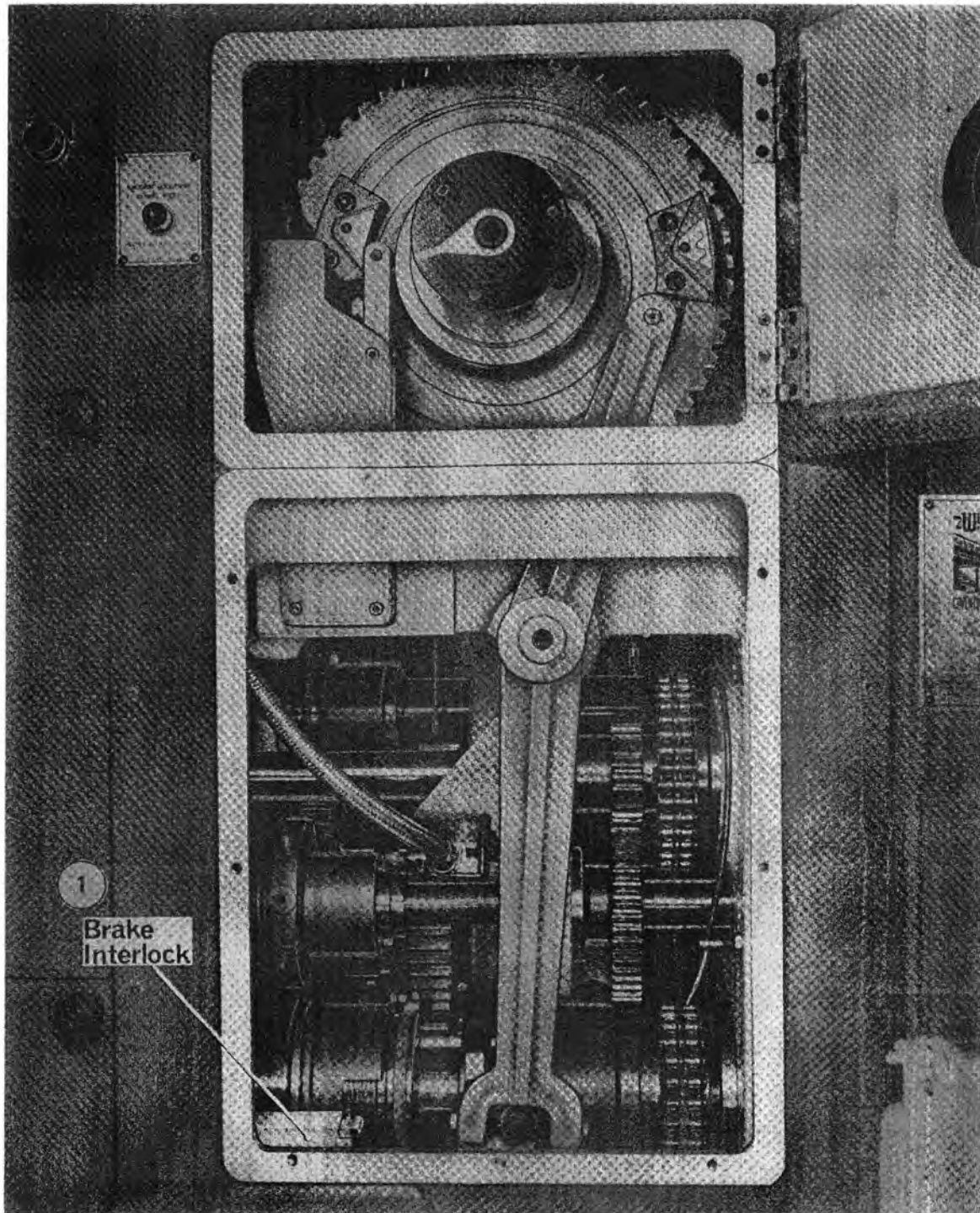
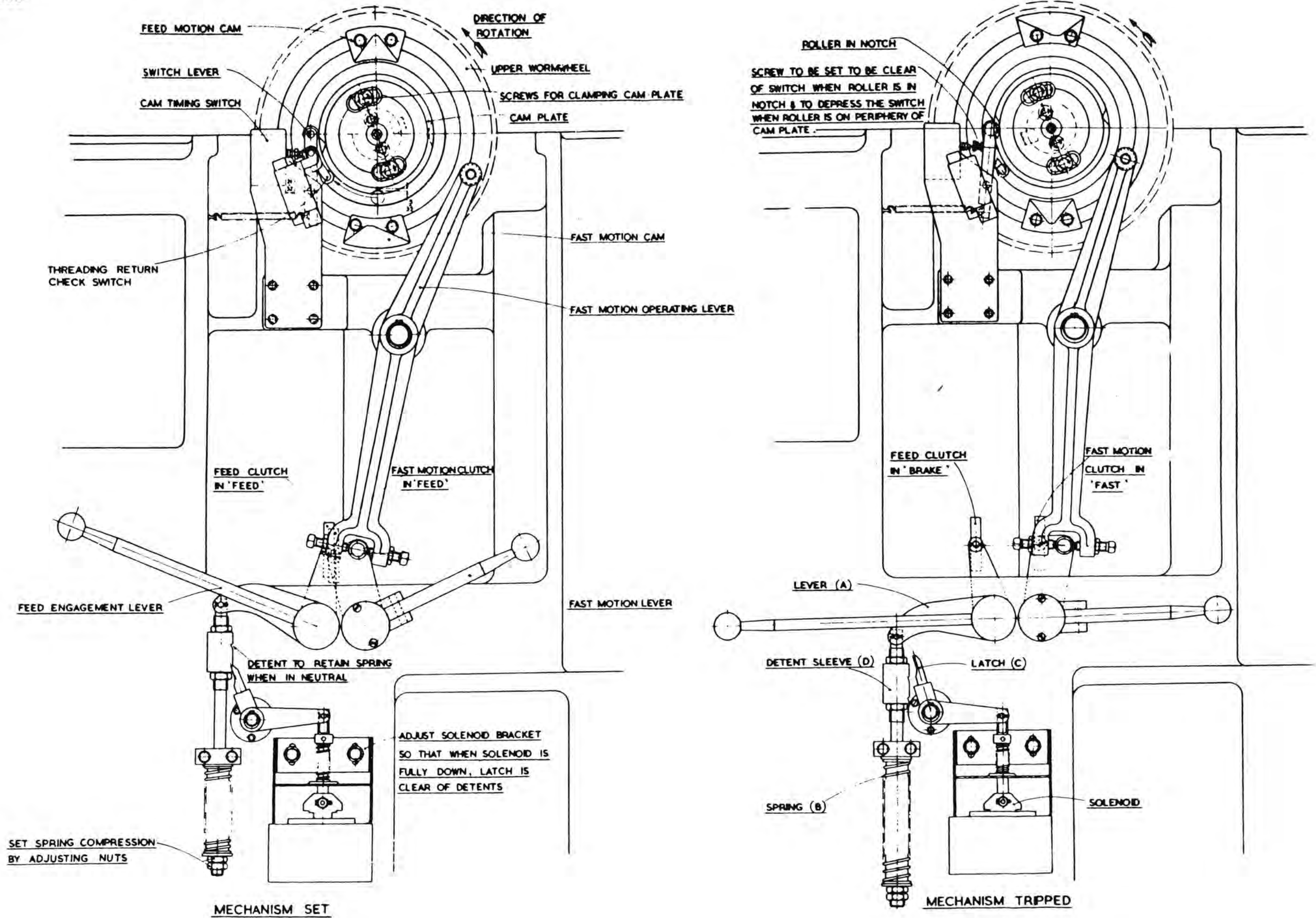

Fig.4.15



4.11 The Main Camshaft

The main camshaft extends from the wormwheel in the main drive housing, passing through the drum housing to the stock carriage end bracket of the machine. The camshaft is supported in plain bearings in the main drive housing attachment drive compartment walls and the walls of the drum housing and its tail end is supported by a ball bearing assembly in the stock carriage end bracket of the machine. It carries the cross slide feed and approach stroke cams, bar stop, bar feed and collet operating cams, spindle drum locking cams, the Geneva arm and roller and the index clutch.

A cam drum is fitted in the main drive housing to carry cams for special end working attachments when these are required and a 2in (50.8mm) bore is provided in both walls of the housing to carry a shaft upon which the necessary cam operating levers can be pivoted.

An auxiliary cam disc is provided in the drum housing to accommodate special cams for varying independently the movements of individual cross slides or cross slide attachments when required. A timing hole is provided in this auxiliary cam disc which lines up with a corresponding hole in the drum housing wall when the camshaft is at 0 degree timing angle.

The keyway in the shaft and the vee grooves across the diameter of the auxiliary cam disc and the spare cam drum, are horizontal and to the front of the machine at 0 degree timing angle. At this point the Geneva roller is just entering the Geneva wheel. See figs. 4.10 and 4.16.

Index clutch operation.

The bar feed cam drum is driven by a dog clutch spring loaded into engagement and carried on the main cam shaft. Lifting the index clutch lever until the plunger handle locates in a hole in an adjacent bracket, withdraws the clutch teeth and renders inoperative bar feed, collet operation, drum indexing and the drum locking mechanisms. An interlock latch is fitted so that the clutch cannot be disengaged during the indexing of the drum. See figs.4.10 and 4.16.

Fig.4.16

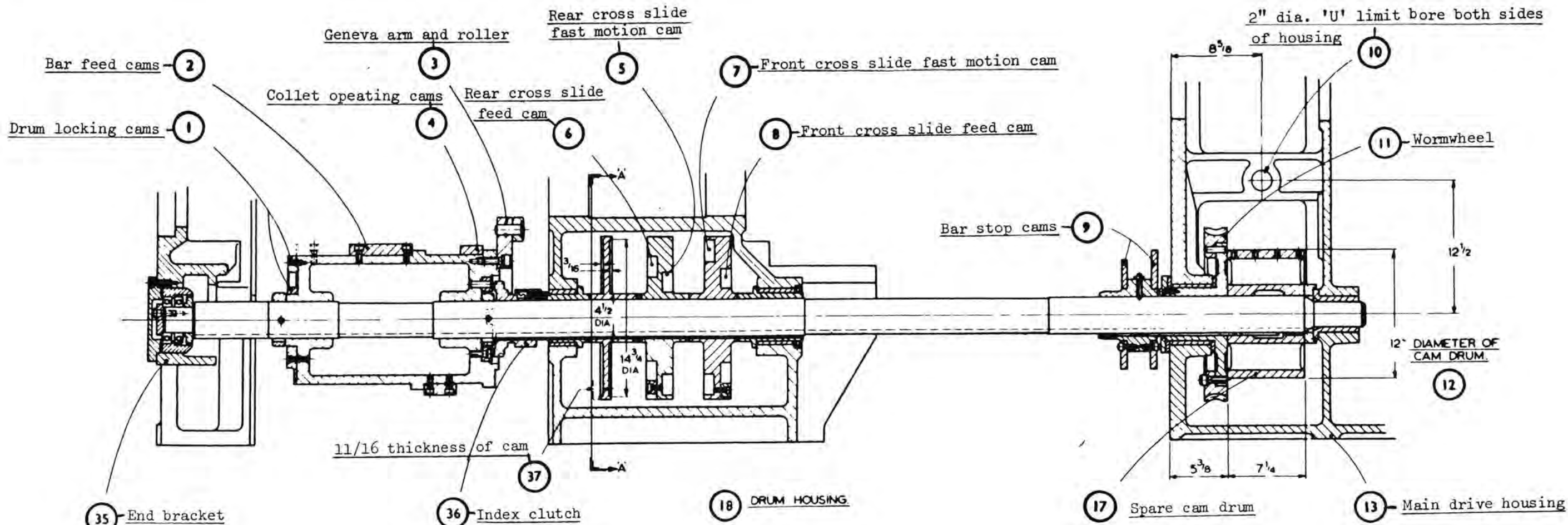

AUXILIARY CAM DISC

OUTSIDE DIA	15 1/4
DIA OF RECESS	14 3/4
DEPTH OF RECESSES	3/16
OUTSIDE DIA OF BOSS	4 1/2
CAM THICKNESS	11/16
DIA OF ROLLER	1 3/4

13 1/4 - 8 UPPER FRONT STN 6 SEC 593B REAR STN 5 SEC 593A	
33	HOLE POSITION
A	-975 TO 1-3
B	-487 TO -65
RADIUS 'R' MAX. 6 1/4 MIN 3 1/8 3 1/8" CAM MOVEMENT.	

13 1/4 - 8 INTER FRONT STNS 7 & 8 SEC 593C INTER REAR STNS 3 & 4 SEC 593	
RATIO OF INTERMEDIATE CROSS SLIDE STROKE TO CAM MOVEMENT ADJUSTABLE FROM 1.0 TO 1.325	
RADIUS 'R' MAX. 6 1/4 MIN 3 1/8 (3 1/8" CAM MOVEMENT.)	

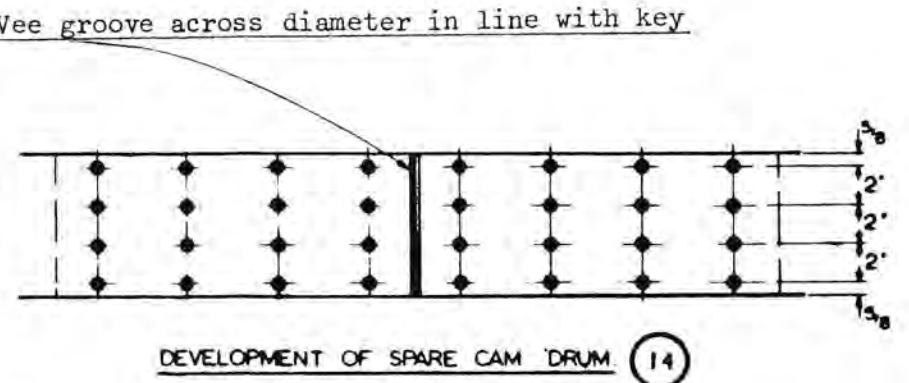
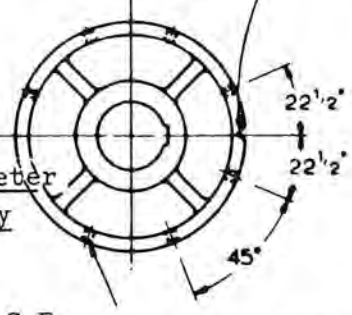
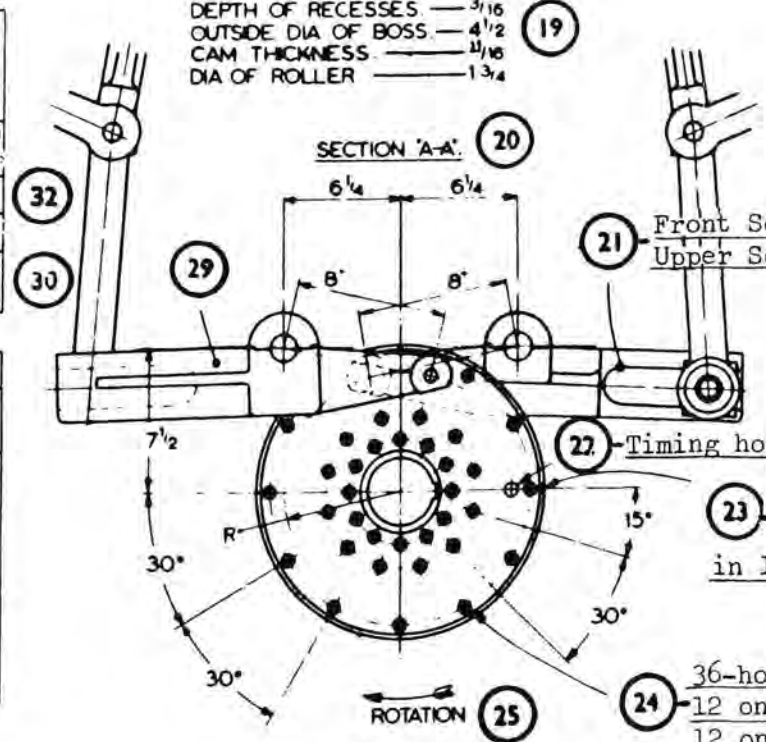

- 24 36-holes 7/16" B.S.F.
12 on 5 1/2" P.C. dia.
12 on 8" P.C. dia.
12 on 13 3/4" P.C. dia.
- 15 32-holes 7/16 B.S. fine across drum
Equally spaced as shown

4.12 Upper Camshaft

The upper camshaft is transversely mounted across the top of the main drive housing. It carries disc cams which operate the centre tool block and the longitudinal slides. Cam carriers are also fitted for cams to operate the 3rd, 4th, 7th and 8th station longitudinal motions.

The cam dogs controlling the fast motion clutch are mounted in a circular tee slot machined in the face of the worm-wheel; a timing dial is provided at the front and rear ends of the upper camshaft.

The worm-wheel drives the upper camshaft through serrations on the face of the wormwheel and a serrated plate engaging a tenon slot in the upper camshaft. By releasing the centre screw and the two outer screws this serrated plate may be disengaged from the worm-wheel. By hand winding the machine, the lower camshaft and the upper worm-wheel may be turned while the upper camshaft remains stationary, thus enabling the timing of the main camshaft and the upper camshaft to be altered or corrected as required. It is vitally important that the serrations engage properly and that the screws are fully tightened after altering the timing.

A vee groove is cut across the periphery of the cam discs and is vertically above the centre of the camshaft at 0 degree timing angle. See figs. 4.17 and 4.18.

Fig.4.17

TIMING SWITCH CAM FOR ENERGISING THE TRIP SOLENOID IN CONJUNCTION WITH THE THREADING ATTACHMENT RETURN CHECK SWITCH

TIMING SWITCH CAM FOR ENERGISING THE TRIP SOLENOID IN CONJUNCTION WITH THE BAR EXHAUSTED SWITCH & THE AUTO-STOP SWITCH

1 3/4" - 8 6" - 8	9" - 4	3 1/2" - 4 4 1/8" - 4
7TH OR 8TH STATION INDEPENDENT	4TH STATION INDEPENDENT	NOT USED
6TH STATION INDEPENDENT	NOT USED	4TH STATION FEED CAM
LOCK BOLT	LOCK BOLT	
CENTRE BLOCK FEED CAM	CENTRE BLOCK FEED CAM	
SLIDING BLOCK IDLE MOTION CAM	SLIDING BLOCK IDLE MOTION CAM	
5TH STATION FEED CAM	3RD STATION FEED CAM	
3RD OR 4TH STATION INDEPENDENT	NOT USED	

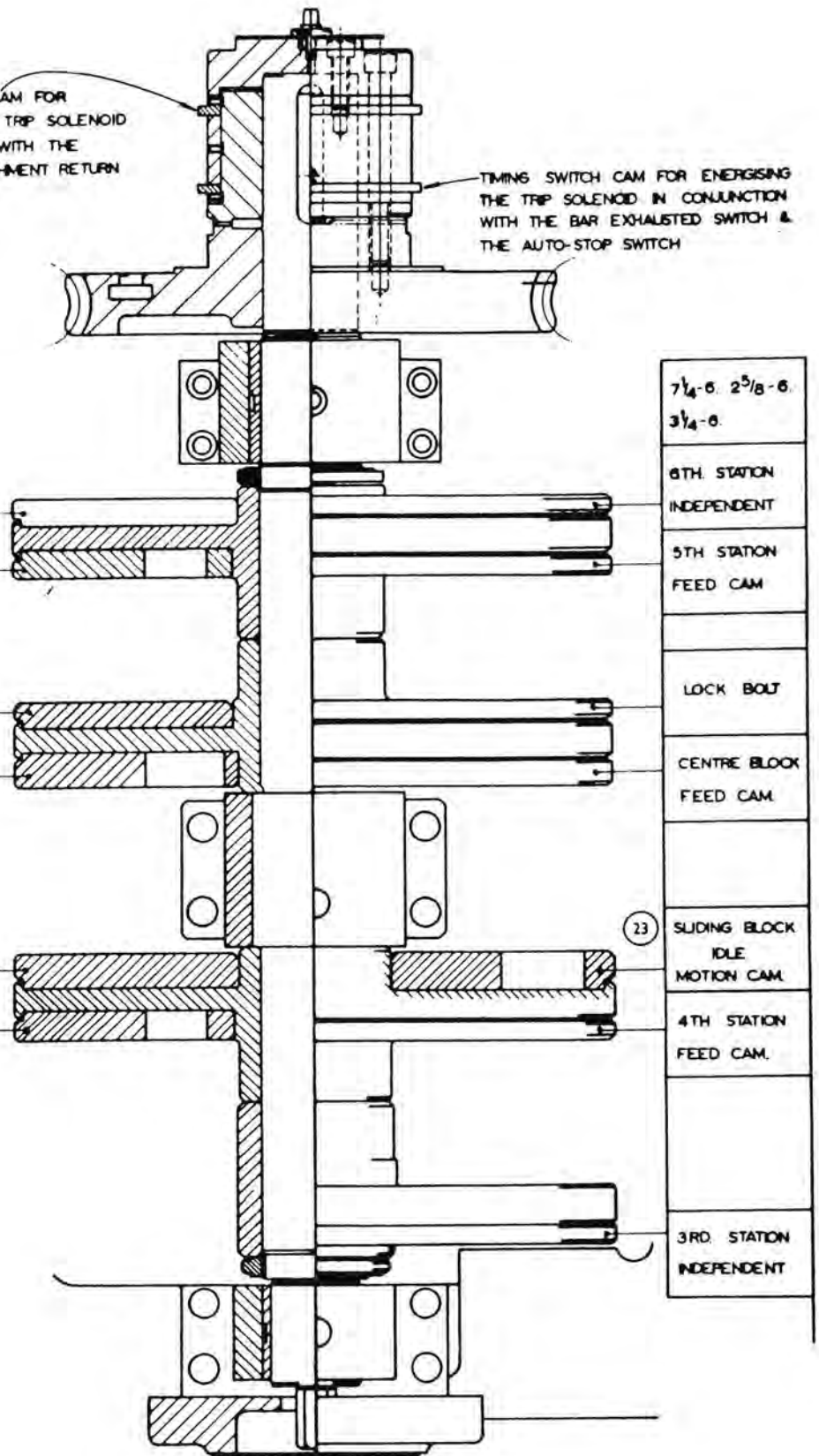
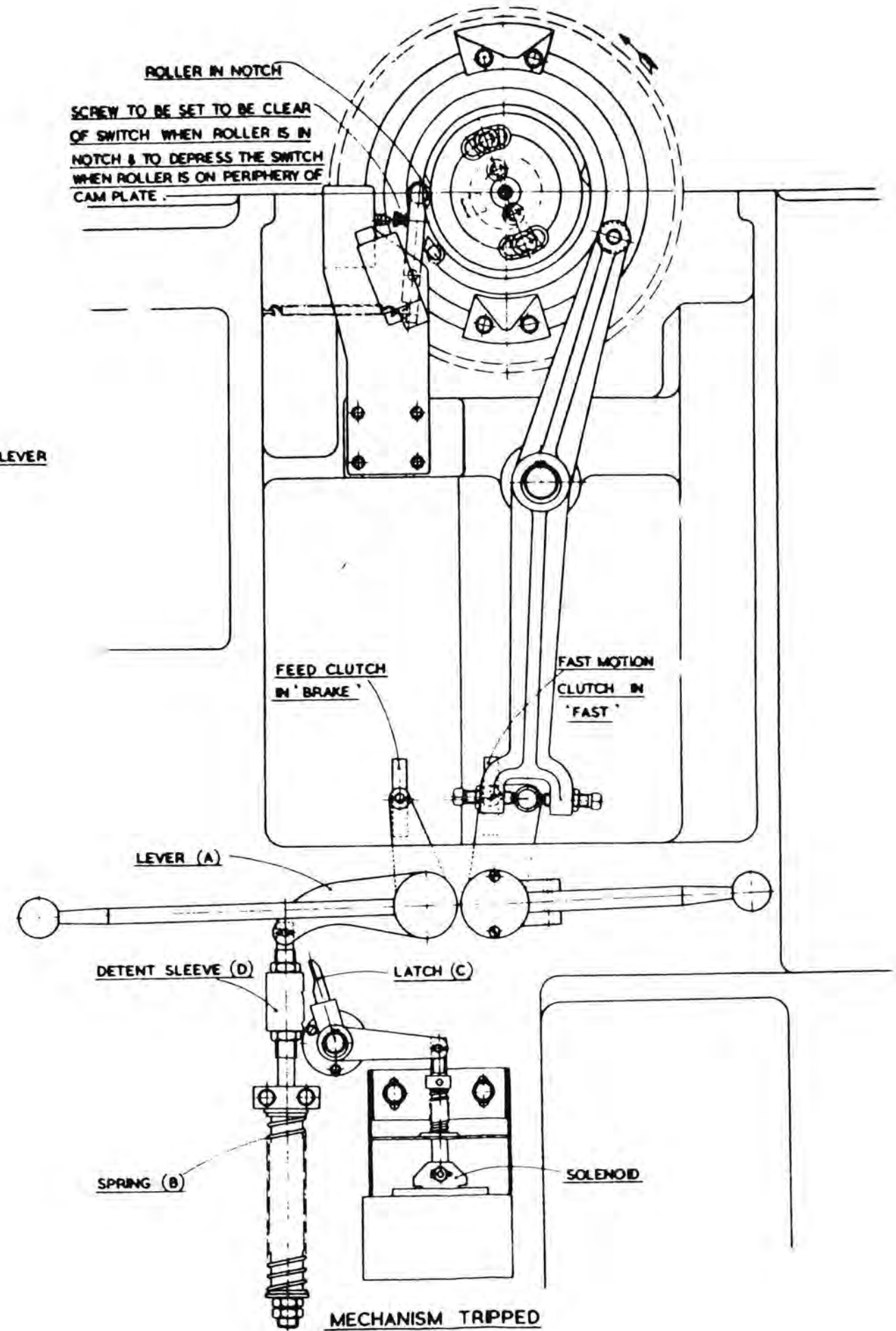
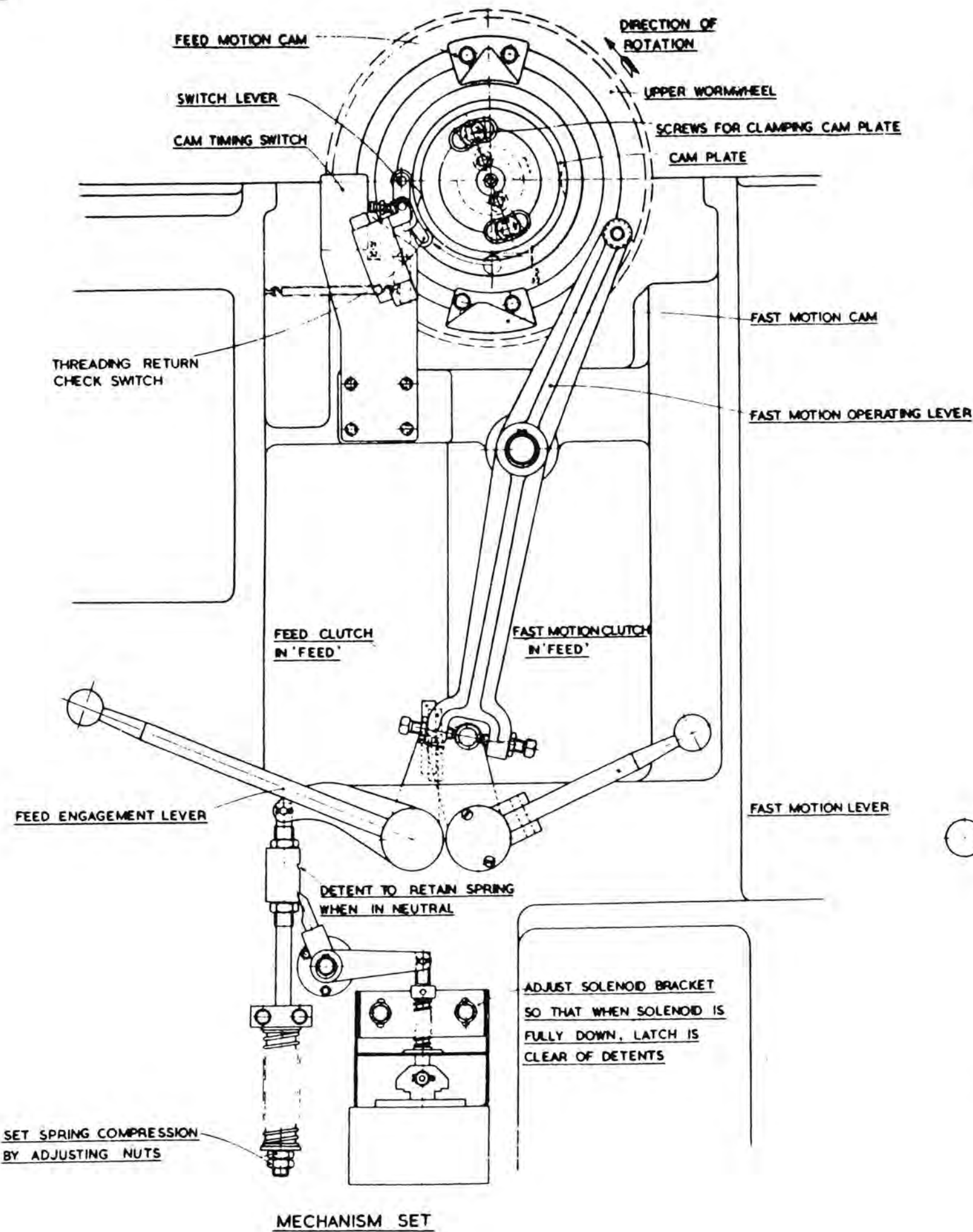

Fig.4.18



4.13 Centre Tool Block and Longitudinal Slides Operating Mechanism

The mechanism derives its motion from cams on the upper camshaft, the three slides being operated by a series of racks and levers to give each slide a constant fast approach stroke and an infinitely variable feed stroke; centre block 0 to 5in (0 to 127mm), independent longitudinal slides 0in to 5.5/8in (0 to 143mm). A sliding block with provision for three sets of pinions and slideways for racks is carried in guides on the top of the main drive housing and when cam operated, imparts the fast motion stroke to the three slides. The block is locked in its forward position and three separate quadrant levers are cam operated to provide the feed motion through the racks and pinions to the slides.

At the end of the fast motion stroke the sliding block lockbolt enters a tapered setting on the block; if the seating is not directly under the lockbolt the block will be moved and consequently double the movement on the toolslides. The setting is shown on figure 4.19. Unless dismantled or cam wear has occurred, adjustment should not normally be necessary. The adjusting procedure is as follows:-

Stop the machine at the end of the fast approach stroke with the lockbolt "IN" and remove the sheet metal covers. Dismantle the lockbolt operating lever by removing its eccentric pivot pin.

Release the spring load on the lockbolt by unscrewing the retaining cap. The spring load is approximately 60lb. (27Kgf) and the cap can be held down by an assistant if the two opposing screws are first removed.

Fit a long B.S.F. fine thread bolt or stud in the thread in the lockbolt to enable it to be pulled clear of its seating. With the lock bolt withdrawn handwind the machine backwards until the sliding block starts to retract, then carefully forwards until the block is just at the maximum forward position on the fast motion cam.

The block should then be moved with gentle blows from a mallet until a 0.003in (0.076mm) feeler can be trapped between the outer part of the cam and the roller. In this position the lockbolt should fit exactly in the tapered seating without moving the sliding block setting. In order to reset the sliding block, release the pad bolt holding the cam roller pin and turn the pin by the hexagonal end to obtain the exact seating condition. The eccentricity must be kept in the lower half as shown on fig.4.18.

After making the adjustment, the pad bolt nut must be tightened to a maximum to prevent pin movement.

Re-assemble the lockbolt operating lever and adjust its eccentric fulcrum by the squared end to just nip the lockbolt down in the seating with the roller on the inner cam. See figs. 4.18 and 4.19.

Fig.4.19

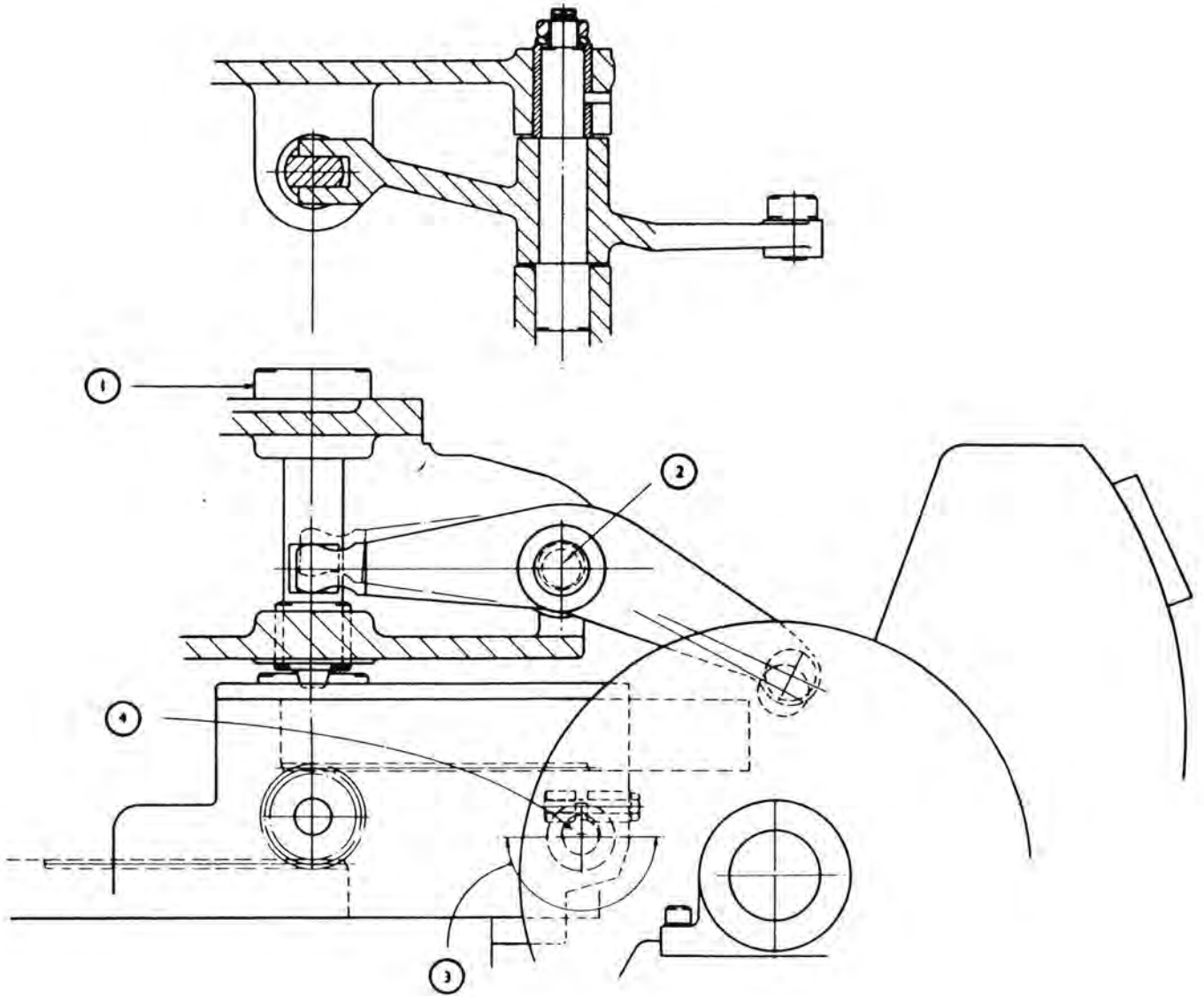

4.14 Changing Feed Stroke

This is dealt with in the Operator's Handbook.

4.15 Changing Fast Motion Approach Stroke

Two alternative cams are available for 3.1/2in (88.9mm) and 5in (127mm) stroke. Changing involves the removal of the upper camshaft.

Auxiliary motions are available for the 3rd, 4th, 7th and 8th stations on the eight spindle machines, see Attachments section in the Operator's Handbook.

4.16 Centre Block and Longitudinal Slides

The centre tool block, fitted with bushes and scraper rings, slides on the centre guide which indexes with the spindle drum. Torque loads are taken against guide faces in the beam by a guide block on top of the guide arm, adjustment for wear being provided by a gib strip. When adjusting the gib strip carefully check the adjustment throughout the travel as wear will tend to occur on the portion covered by short strokes. Access is through the covers on top of the beam, see fig. 4.20.

Oil is fed from drip points in the beam to a strainer on the guide block and down a pipe to the reservoir between the bushes in the centre tool block. Drain and filler plugs are provided for periodical draining and flushing out.

The centre tool block is pushed by a double link from the lower centre rack and no endwise adjustment is provided. The stop rod is provided to control length accuracy. Stop nuts should be slackened off well clear before adjusting slide strokes as the final position of the tool block is not constant for all strokes.

The faces and the tenon slots of the tool block are ground to close tolerances and standard toolholders and attachments may be fitted to any face without selection for height or centrality.

The longitudinal slides are mounted on vee guides fitted on the beam which are accurately adjusted for alignment and centrality by a tenon block secured to each end of the vee guide. Screws in the beam clamp the blocks to one side of a beam slot.

Tapered gib strips are provided and the headed screws at each end of the slide should be adjusted with the tool (573X108) supplied in the tool kit.

Each slide is pushed by a rod screwed into the pusher bar and is adjustable for position 3.1/2in (88.9mm) by means of nuts on the rod. A spacer between the nuts is slightly wider than the bracket on the slide to allow for slight misalignment of the pusher rod.

As with the centre tool block, stops should be well clear before adjusting strokes.

Fig.4.20

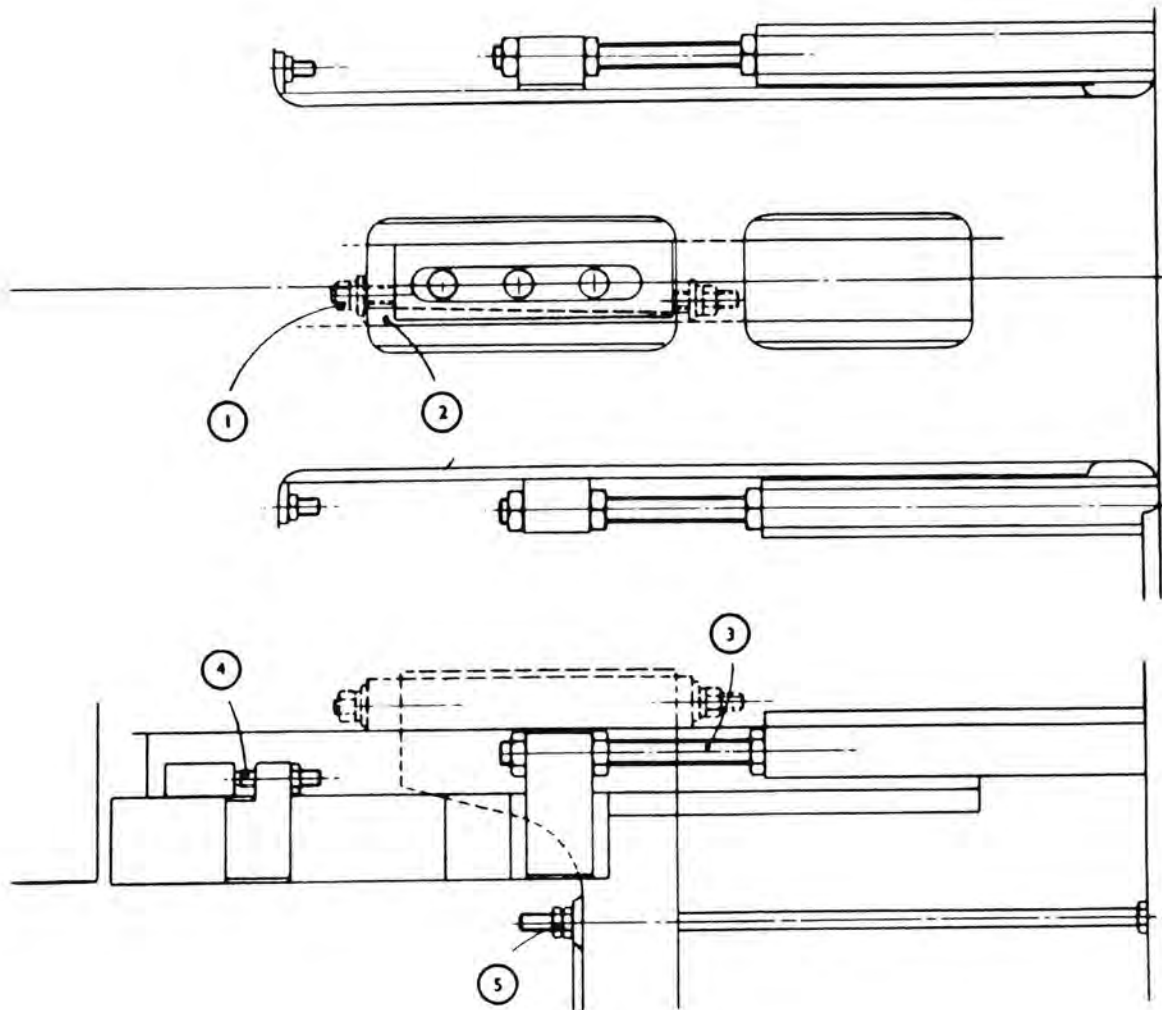

4.17 Cross Slide Operation Mechanism

The mechanism is situated in the drum housing and consists of a series of levers and pivoted links operating upon gear quadrants and racks to give the slides a two part motion of fast approach and withdrawal and a slow feed similar to the longitudinal slides.

The fast approach is by cam operated toggles, actuating two heavy "rocking" levers through a short arc. A cam on the main camshaft extends a toggle, swinging the front lever pivot on two stop screws in the drum housing floor. A second cam on the main camshaft imparts a similar motion to the rear rocking lever. Adjustment to the stop screws should only be required after a long period of service, fig. 4.21 illustrates and explains the adjustment.

Clamped into the tee slots on the rocking levers are adjustable link pivots with links extending to suitable levers on the cross slide operating shafts. An extension on each rocking lever carries a cam roller controlled by the feed motion cams on the main camshaft.

Figure 4.22 shows the adjustment provided for meshing the gear quadrants and racks on the lower cross slides.

All cross slides have independent feed stroke setting, adjustable by sliding the appropriate link pivot along the rocking lever tee slot to a setting indicated by a pointer on a scale. See also "Operating Adjustments" in the Operator's Handbook.

The upper cross slides have a double range of feed strokes, the "long" range being equal to twice the scale reading. The change-over is obtained by transferring the upper link pivot connection from the outer hole "B" to an inner hole "A" in the operating lever. It is necessary to remove a retaining circlip on the pivot pin and to restrain the slide spring load with a pressure on the top of the operating lever to withdraw the pin.

Changing intermediate cross slide feed stroke range

The changeover, as on the upper slides, is by transferring the link pivot from an outer hole "B" in the operating lever to an inner hole "A".

Access to the operating lever is by removing the screwed cover on the side of the drum housing.

Set the maximum stroke on the rocking lever scale and with the slides in the withdrawn position adjust the micrometer head to bring the slides to the maximum back position. A hexagon headed bolt clamps the link pivot to the operating lever, the bolt passing through the lever into the threaded pivot. Unscrew and withdraw the bolt and slide the link and pivot along a slot in the lever to the alternative hole setting. It is necessary to restrain the slide return spring with pressure on the operating lever or the end of the slide. Replace the clamp bolt and set the feed stroke and the slide position as required.

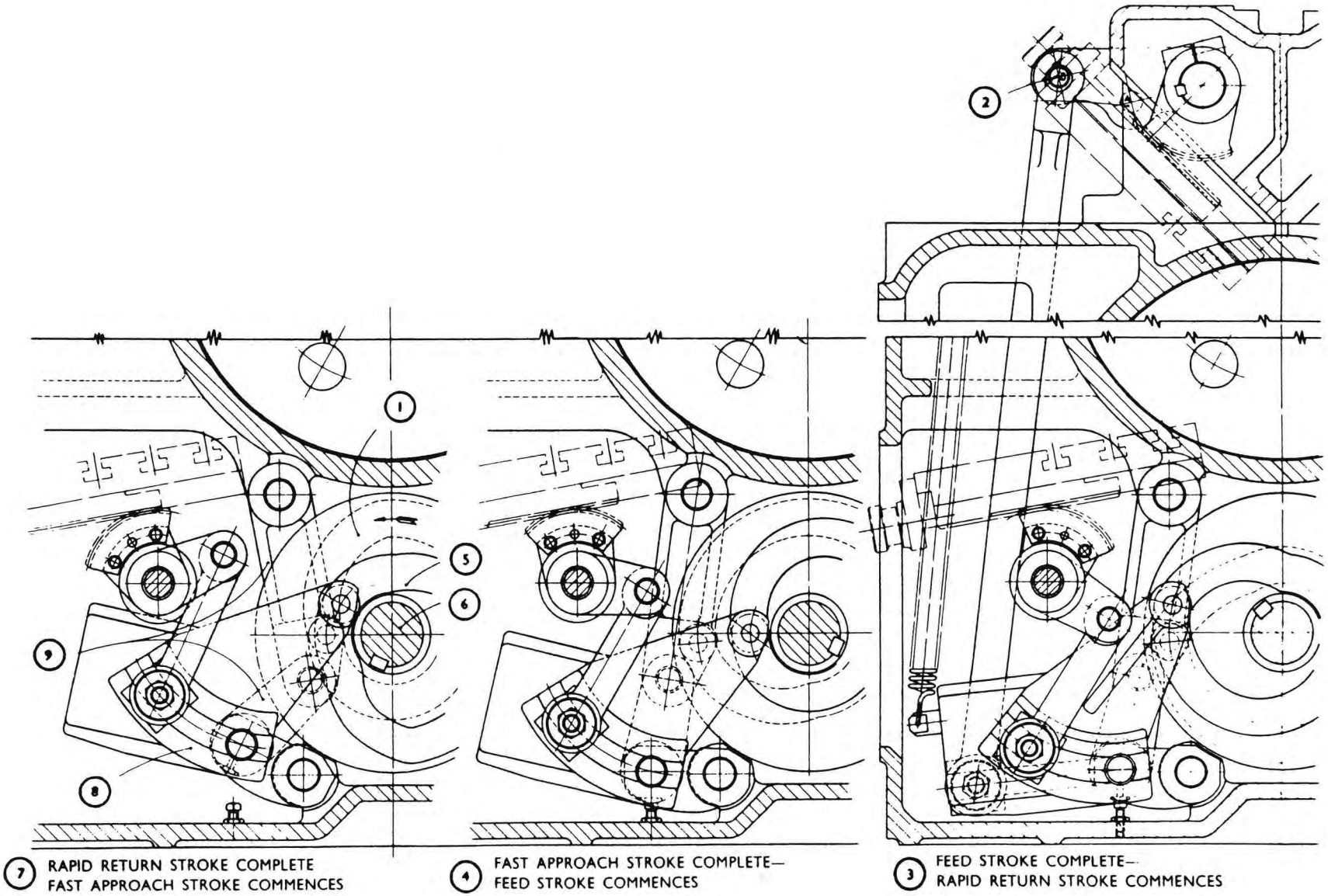

7 RAPID RETURN STROKE COMPLETE
FAST APPROACH STROKE COMMENCES

4 FAST APPROACH STROKE COMPLETE—
FEED STROKE COMMENCES

3 FEED STROKE COMPLETE—
RAPID RETURN STROKE COMMENCES

Fig.4.22

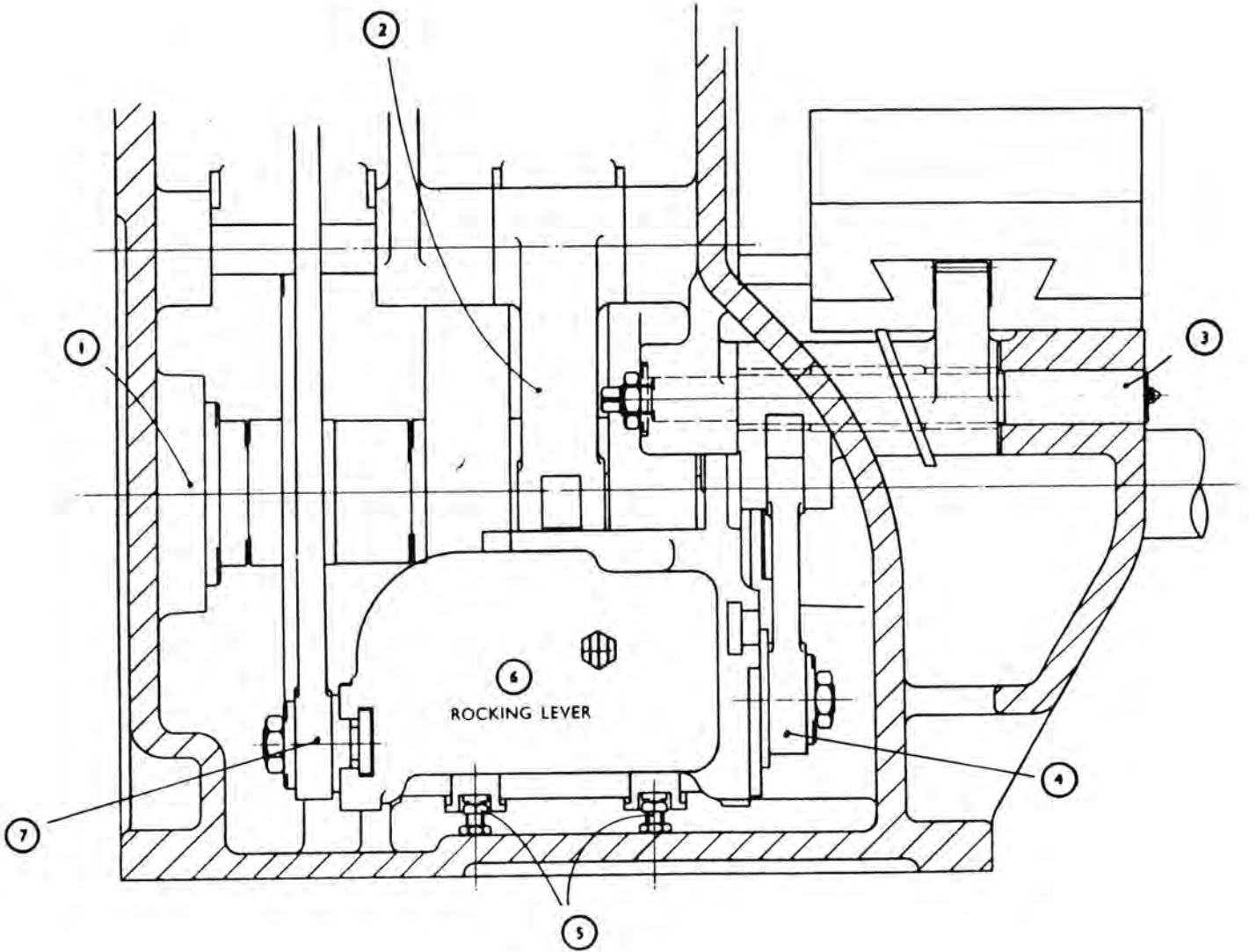

4.18 Bar Stop and Operation

Operating adjustments are described in the "Operator's Handbook". The bar stop movement is derived from two cams on the main camshaft, operating on a lever fitted with two cam rollers. One cam and roller swings the bar stop into position and the other returns the bar stop after bar feeding. The lever is connected to an upper operating lever on the bar stop shaft by a spring box link, the bar stop shaft being carried on brackets between the housings. The mechanism is protected by a front and rear cover secured to the main drive housing attachment face. Normal operation swings the bar stop up from between the lower cross slides to the first station spindle centre, the upper operating lever contacting an adjustable stop and compressing the spring box 1/8in (3.17mm).

The bar stop can be arranged to swing over the first station slide by fitting the upper spring box pivot connection and operating lever on the opposite side of the bar stop shaft. The front cover should be removed, the adjustable stop in the support bracket released and withdrawn, and the lock-nut on the top of the spring box link unscrewed. The spring link can then be disconnected from the lever by turning the hexagon on the spring shaft at the top of the tube clockwise. This should detach the operating arm which together with the shaft, can be turned over and reconnected to the spring box. The bar stop and the bar stop arm should then be re-aligned to the spindle and the dead stop fitted in the location provided and adjusted to compress the spring box 1/8in (3.17mm). The bar stop is formed with a shaft end which is clamped in the bar stop arm. A square headed screw acts on the shaft end for fine adjustment.

4.19 Automatic Stop Mechanism

The automatic stop system covers two sets of circumstances:-

(A) Those circumstances where it is necessary to stop the feed and spindle rotation at the end of the cycle. Such circumstances are:-

- 1.Bar exhaustion.
- 2.Incorrect lubrication pressure or failure.
- 3.Threading attachment fails to return.
- 4.Safeguarding certain special attachments.
- 5.Pneumatic or hydraulic pressure failure where applicable and automatic stop at end of cycle is permissible.

(B) Those circumstances where it is necessary to stop the feed and spindle rotation immediately in order to safeguard operating personnel and equipment such as:-

- 1.Slipping clutches thrown out of engagement.
- 2.Pneumatic or hydraulic pressure failure when this type of equipment is used.
- 3.All safety aspects which demand instant termination of feed and spindle rotation.

The chart shown at fig. 4.23 is a guide to the normal reasons for the machine stopping either at the end of a cycle or immediately.

The automatic stop action is created by a switch, the two timed stops being:-

(a) After drum indexing with the collet open and the bar feed slide forward.

(b) With the slides withdrawn clear of the components just before indexing.

In order to stop as outlined in (a), a cam timing switch, see fig. 4.18 is operated by the cam plate on the upper camshaft in conjunction with the switch operated by the forward additional feed of the bar feed slide, and with the three position selector switch marked; SET UP, TRIP and RUN, and mounted in the front pendant control panel, set in the RUN position.

During bar feeding, the forward motion of the bar feed slide is stopped approximately 1/2in (12.7mm) short of its available travel by the bar contacting the bar stop. When the bar is so short that the bar feed slide is able to move an extra 1/4in (6.35mm), a switch adjacent to the bar feed slide is operated by the slide to prepare a circuit, such that with the operation of the cam timing switch on the upper camshaft being activated, the electro-magnetic feed clutch and brake is de-energised stopping the feed. It also causes the main motor contactor to open and stop the main motor, see the wiring diagrams for a full explanation of these circuits. A similar use of the cam timing switch, combined with pressure switches in lubrication, pneumatic or hydraulic circuits if employed, de-energise the electro-magnetic feed clutch and brake if a failure occurs in such systems.

In order to stop as outlined in (b), an extra cam timed threading return switch, mounted parallel to the cam timing switch and activated by the cam on the upper camshaft, will de-energise the electro-magnetic feed clutch and brake should the threading attachment fail to retract and activate the threading return switch mounted adjacent to the main drive housing attachment face. As the panel relay is not affected, the motor and machine spindles are left running. See wiring diagrams for a full explanation of these circuits.

In addition to stopping as outlined in (a) and (b), the operation of a switch adjacent to the feed overload clutch will directly de-energise the electro-magnetic feed clutch and brake, stopping the feed instantly during any part of the machine cycle. Other switches can also be employed to stop the feed instantly for safety purposes on special attachments etc. The setting of the overload clutch is shown on fig. 4.24.

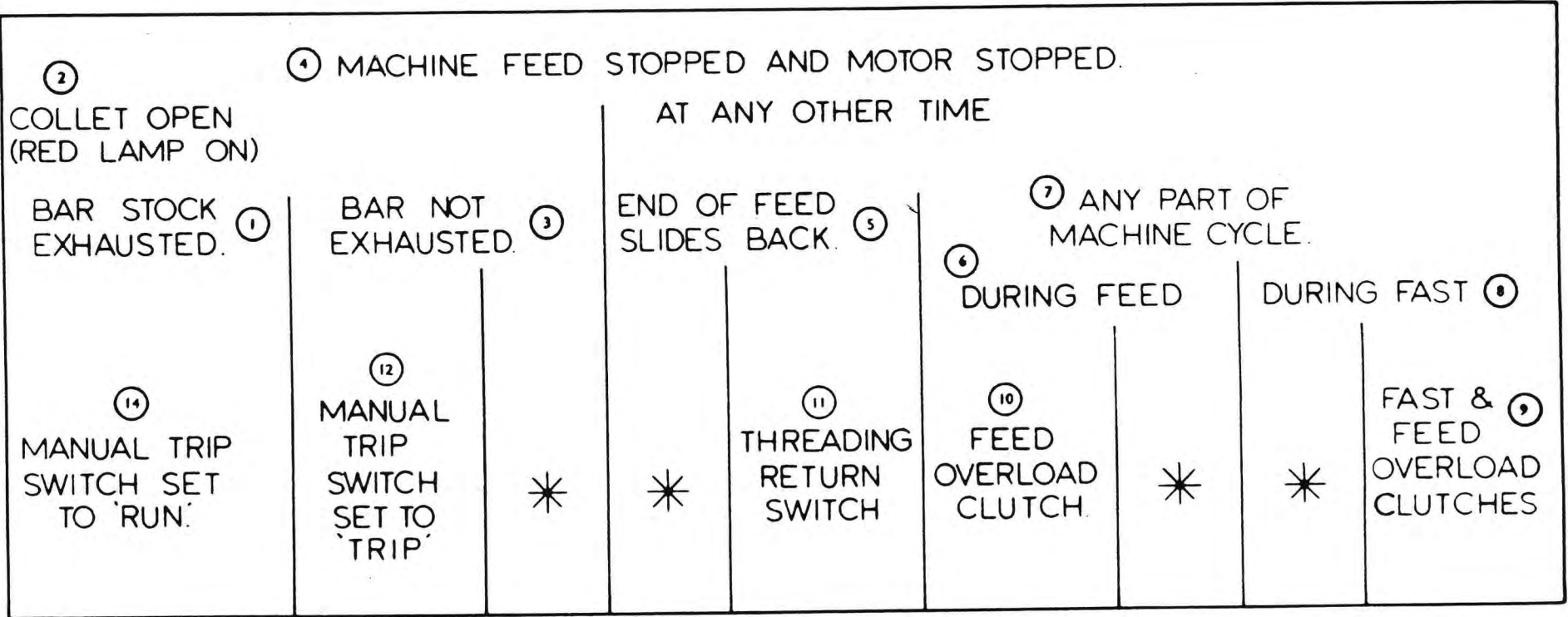

⑬ * SWITCHES FITTED TO SPECIAL ATTACHMENTS.

Fig.4.24

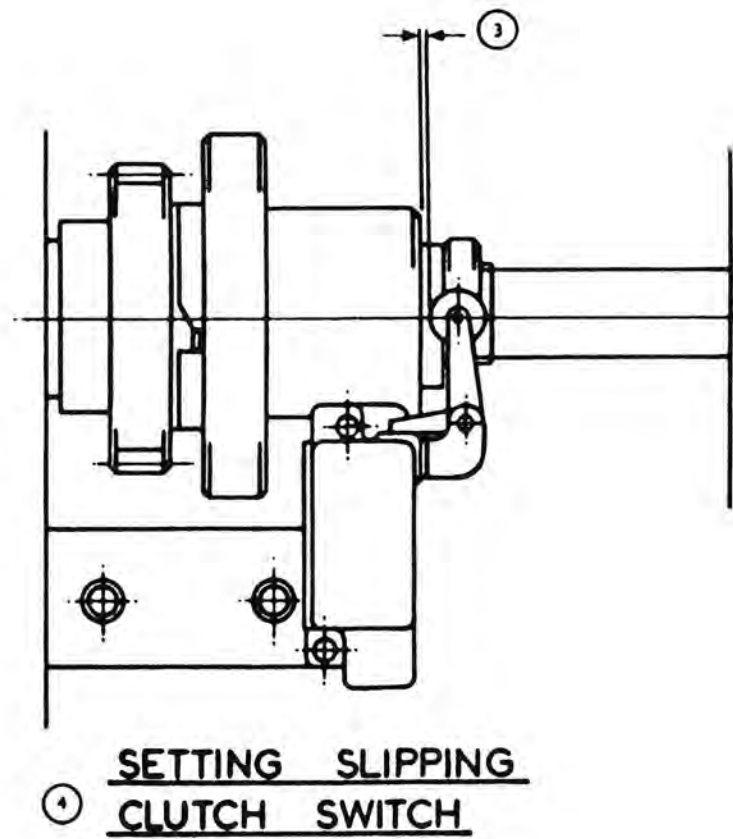
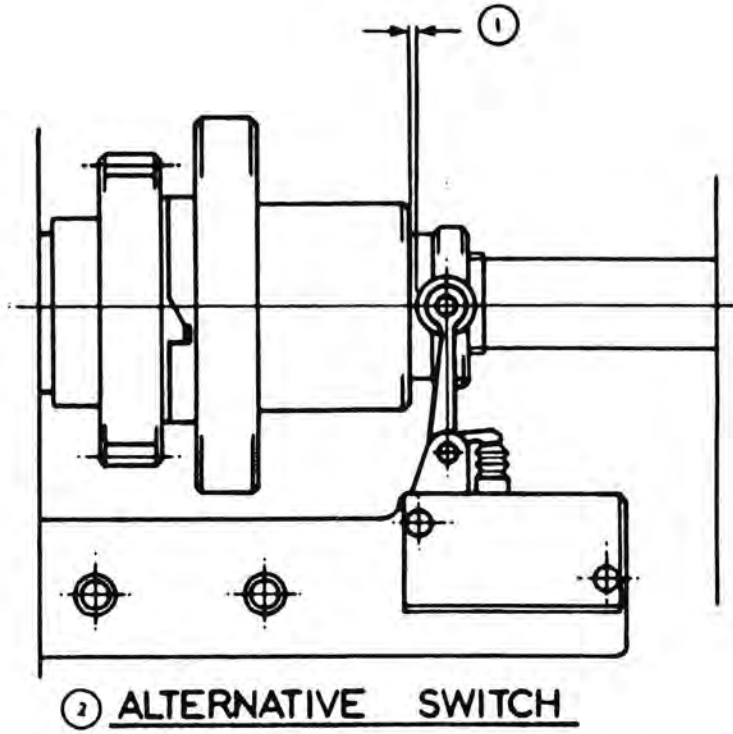

4.20 Coolant

The coolant is supplied from the machine tray by a gear pump, chain driven from the constant speed shaft. Chain adjustment is described on page..... An adjustable gland is fitted to the driving shaft to prevent leakage and this should be adjusted as lightly as possible to prevent overheating and pump seizure. A relief valve is fitted in the pipe system to return excess coolant to the tray. Coolant taps are arranged adjacent to the lower cross slides and on headers on each side of the machine beam and additional plugged holes are provided in the headers.

The chain drive should be removed when the machine is to be run without coolant in the machine tray.

The strainer box and weir must be in position at all times to prevent swarf entering the supply pipe. The strainer is fitted with a loose lid and should be inspected and cleaned at regular intervals, see fig. 4.25.

Machines constantly working on operations requiring oil fed cutting tools can be equipped to special order with an additional high pressure pump and a filtration system, either of the magnetic drum type or one of the centrifugal type dependent upon the material to be machined and the type of coolant to be used. For these systems, pipe work is installed to draw the supply from a strainer in the machine tray or from a separately piped supply. Filtration systems using proprietary items should be cleaned and serviced as directed by the maker's instructions.

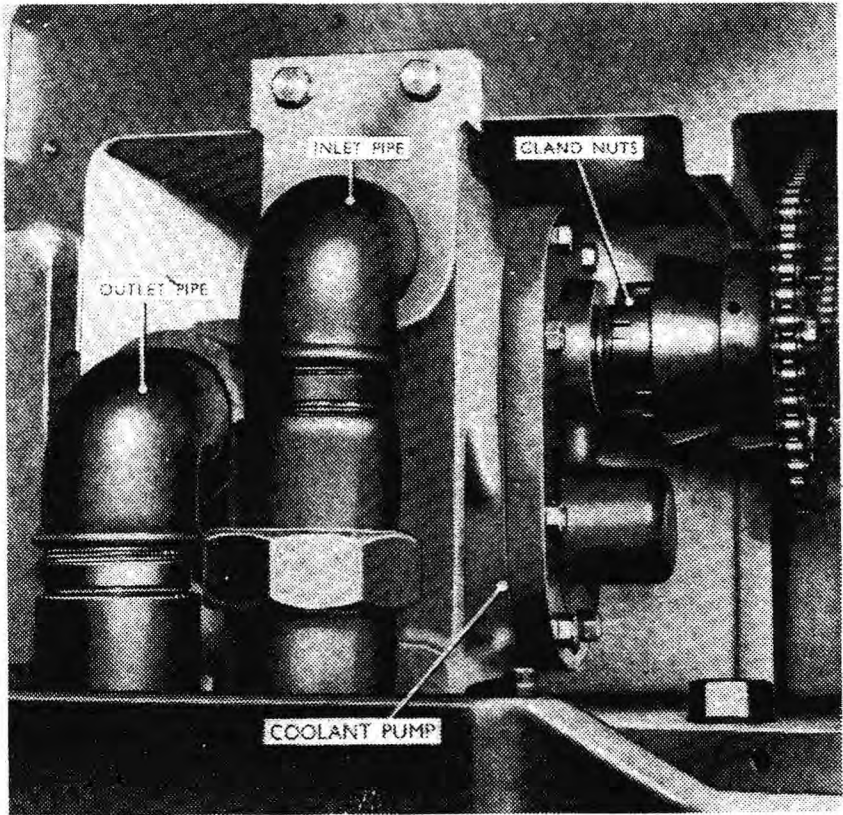

Coolant Pump

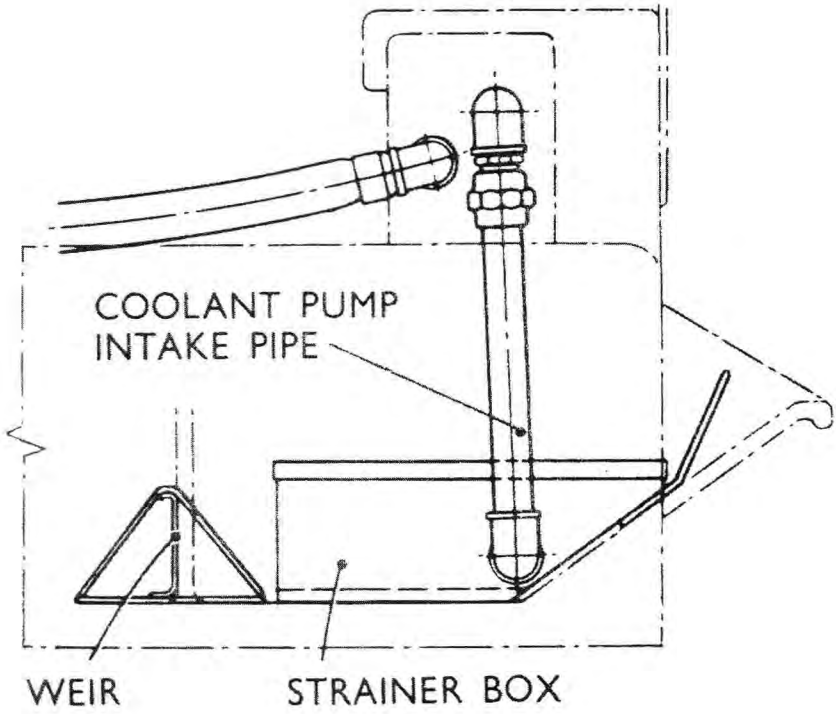

Coolant Pump

4.21 Stock Carriage

The two main parts, the stand and the tube assembly, are erected and aligned as described in the Operator's Handbook. The tube assembly has a central tube to which are secured two tube carriers to space and guide the stock tubes. The rear carrier is supported on rollers in the stock carriage stand.

At the machine end, the front carrier is gear driven during indexing by a pinion from the drum indexing mechanism and must be correctly meshed to the marks on the gears. The stock tubes are located by a by a flanged sleeve secured to each tube and clamped in pairs to the front carrier.

The tubes should be handled carefully; bent or distorted tubes will make it more difficult to slide the tubes through the carriers.

Convoluted spring linings to provide resilient support for the bar stock are not normally required, but are available to order. Where supplied, springs should be kept well lubricated with soft grease.

4.22 Swarf Conveyor

The swarf conveyor is fitted as an optional extra, but conduit and wiring is normally fitted to all machines, from the panel terminals to a junction box on the beam to simplify later installation. A conveyor unit supplied separately includes control buttons and contactor for panel mounting and conduit, wiring and a "Nippon" socket for installation to the machine.

The screw type conveyor is driven by a 1/4 h.p. motor and a reduction gear box, controlled by push buttons on the pendant control panel door.

A shear pin in the coupling adjacent to the motor gear box provides overload protection in addition to that provided by thermal trips in the motor starter. Spare silver steel shear pins are supplied in a container clipped to the side of the conveyor. Before replacing a shear pin, the cause of the overload should be found and removed. Holes are provided in the end of the conveyor screw so that it can be turned by hand.

Steel chutes are fitted in the tray between the housings to guide the swarf into the conveyor. When the conveyor is fitted the coolant intake pipe extends to the drum housing end of the machine, as illustrated on fig. 4.26. The main overflow of coolant is discharged into a basket under the main drive housing collecting the fine particles of swarf held in suspension in the coolant. The basket is accessible from the end of the machine and should be emptied at regular intervals.

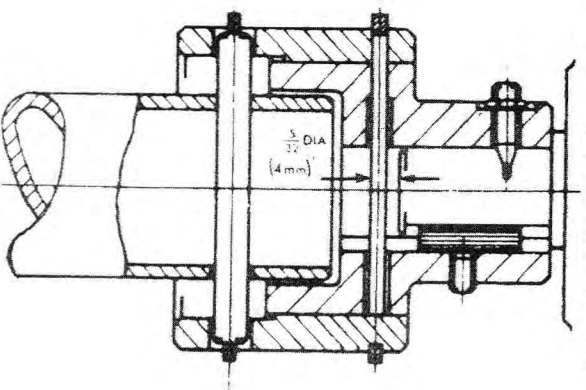
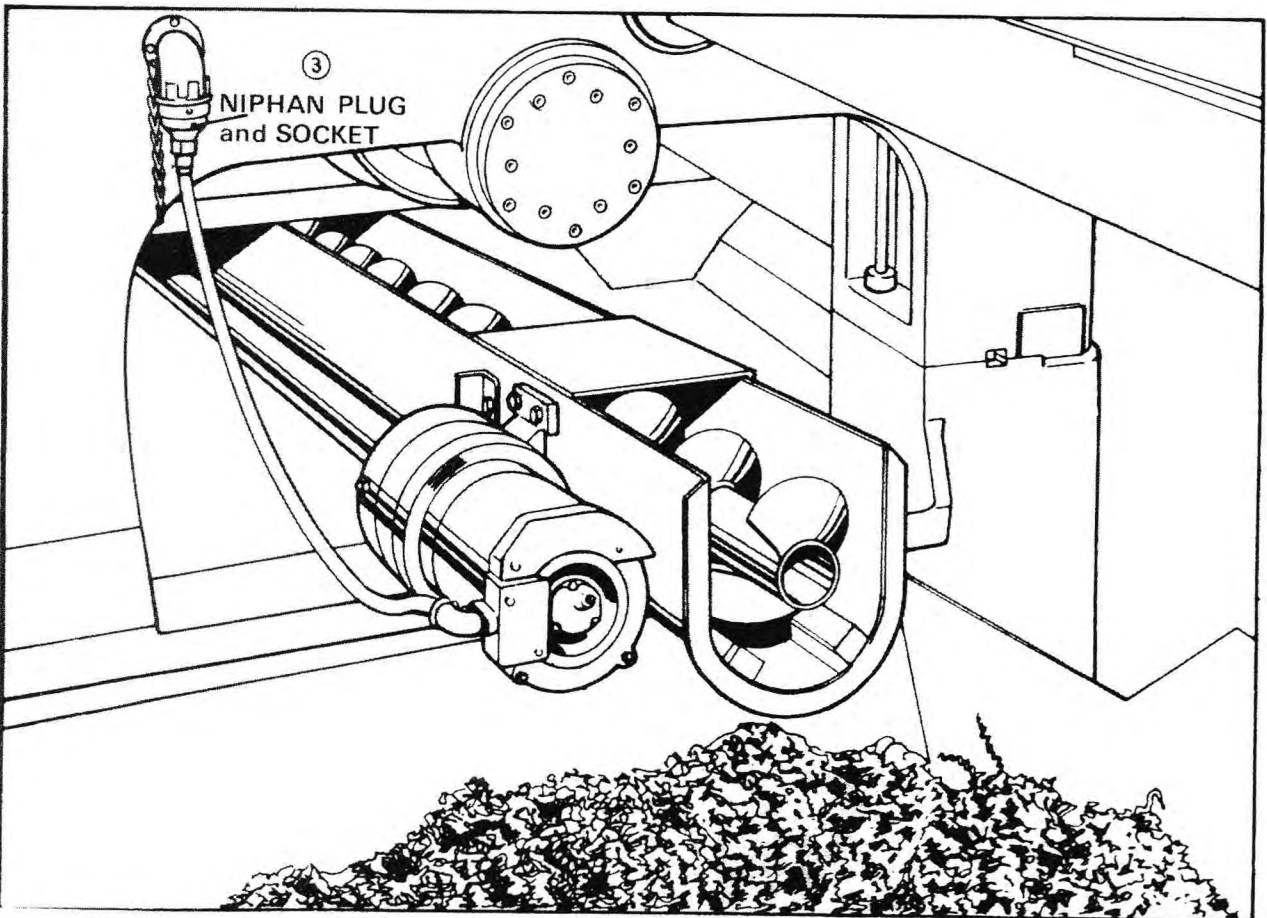
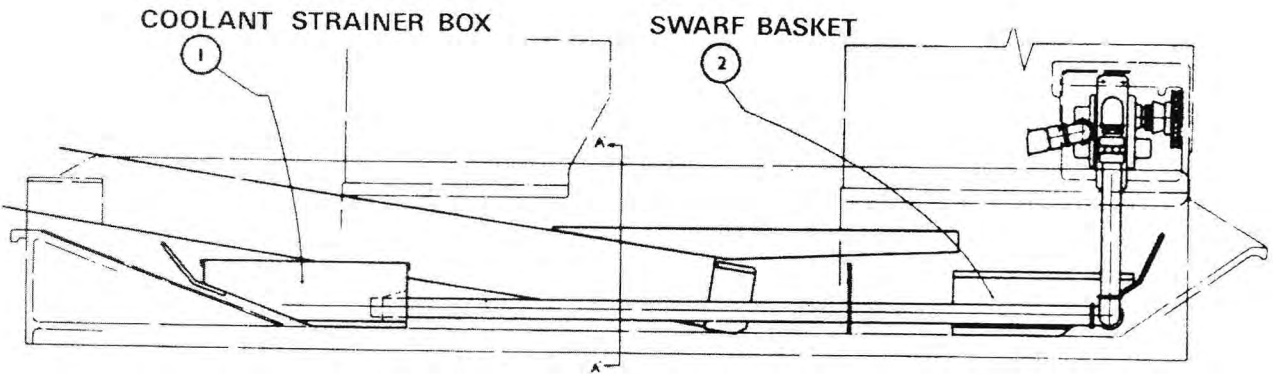

SECTION FIVE - PARTS LISTS AND MACHINE DRAWINGS

SECTION FIVE, PARTS LISTS AND GENERAL ARRANGEMENTS.

AUTOMATIC STOP - DRAWING NO. 520 Z 1A

<u>INDEX</u> <u>NO.</u>	<u>PART</u> <u>NO.</u>	<u>TITLE</u>
1	241/13	3/8" B.S.F. Bakelite Knob, 1.1
2	519X.146	Feed Lever
3	519X.179A	Lever Boss
4	519X.171	Lever Boss Key
5	176/0506	5/16" B.S.F. Socket Set Screw,
6	519X.147A	Feed Lever Shaft
7	173/04L	1/4" B.S.F. Hexagon Locknut
8	176/0410	1/4" B.S.F. Socket Set Screw,
9	519X.192	Glut Pin
10	519X.111	Glut
11	520X.111	Glut Lever
12	156/206	2 B.A. Socket Cap Screw 3/8" long
13	519X.172	Key for Sliding Gear
14	520X.115	Interlock
15	173/08L	1/2" B.S.F. Hexagon Locknut
16	182/0824	1/2" B.S.F. Socket Set Screw, Taper Point 1.1/2" lg
17	101/20	1.3/4" dia. External Seeger Circlip
18	520X.114	Spacer
19	520Y.101	Spring Lever
20	522Z.105	Main Drive Housing
21	520Y.112	Glut Sleeve Lever
22	--	"Compo" Bearing CT.045. 1.1/8" x 1.1/4" x 1.1/4" lg
23	520X.113	Lever Boss
24	176/0508	5/16" B.S.F. Socket Set Screw, Cone Point 1/2" long
25	519X.171	Lever Boss Key
26	241/13	3/8" B.S.F. Bakelite Knob
27	X.146	Feed Lever
28	182/0612	3/8" B.S.F. Socket Set Screw, Taper Point 3/4" long
29	520X.124	Link Pin
30	127/0404	3/16" dia. Split Cotter Pin, 1/2" long
31	520X.116	Trip Latch
32	125/1218	3/16" dia. Taper Pin, 1.1/8" long
33	520X.103	Trip Lever
34	MSE.317	Morris Stock Spring
35	143/0824	1/4" dia. Mill's Grooved Pin, 1.1/2" long
36	143/0820	1/4" dia. Mill's Grooved Pin, 1.1/4" long
37	520Y.128	Automatic Stop Cover
38	520X.109	Solenoid Link
39	155/0556	5/16" B.S.F. Socket Cap Screw, 3.1/2" long
40	520X.124	Link Pin
41	127/0404	1/16" dia. Split Cotter Pin, 1/2" long
42	520X.110	Spring Collar
43	125/1218	3/16" dia. Taper Pin, 1.1/8" long
44	520X.119	Solenoid Spring
45	167/0614	3/8" B.S.F. Hexagon Head Set Screw, 7/8" long
46	130/06	3/8" dia. Plain Washer
47	520Y.102A	Solenoid Mounting
48	167/0408	1/4" B.S.F. Hexagon Head Set Screw, 1/2" long
49	0/04	1/4" dia. Plain Washer
50	173/04L	1/4" B.S.F. Hexagon Locknut
51	168/206	2 B.A. Hexagon Head Set Screw 3/8" long.

**Refer to drawing
showing all part
numbers**

AUTOMATIC STOP - DRAWING NO. 520-Z-1A

<u>INDEX</u> <u>NO.</u>	<u>PART</u> <u>NO.</u>	<u>TITLE</u>
52	FX.5416A/2	Solenoid
53	520X.120B	Solenoid Cover
54	--	G.E.C. Connector C.7025
55	156/412	4 B.A. Socket Head Cap Screw, 3/4" long
56	174/4	4 B.A. Hexagon Nut
57	154/4	4 B.A. Spring Steel Washer
58	173/10L	5/8" B.S.F. Hexagon Locknut
59	520X.126	Spring Seat
60	520X.118A	Clutch Operating Sleeve
61	20X.126	Spring Seat
62	155/0744	7/16" B.S.F. Socket Cap Screw, 2.1/4" long
63	154/07	7/16" dia. Spring Washer
64	520X.127	Spring Thrust Block
65	520X.125	Spring Rod
66	101/6	3/4" dia. External Seeger Circlip
67	121/0620	Key, 3/16" square, 1.1/4" long
68	520X.117	Latch Sleeve
69	173/12L	3/4" B.S.F. Hexagon Locknut
70	520X.122	Trip Lever Pivot
71	155/0416	1/4" B.S.F. Socket Cap Screw, 1" long
72	154/04	1/4" dia. Spring Washer
73	173/04L	1/4" B.S.F. Hexagon Locknut
74	167/0416	1/4" B.S.F. Hexagon Head Set Screw, 3/8" long
75	173/04L	1/4" B.S.F. Hexagon Locknut
76	176/0408	1/4" B.S.S. Socket Set Screw, Cone Point, 1/2" long
77	120X.108	Spring Anchor
78	520X.108	Cam Ring
79	168/424	4 B.A. Hexagon Head Set Screw, 1.1/2" long
80	154/4	4 B.A. Plain Washer
81	520X.105	Switch Lever Spring
82	154/04	1/4" dia. Spring Washer
83	155/0424	1/4" B.S.F. Socket Cap Screw 1.1/2" long
84	520Y.106	Switch Bracket
85	--	Burgess Micro Switch Mk.3/M.S./109 (normally closed)
86	520X.104	Switch Lever
87	520X.107	Pivot Pin
88	125/1014	5/32" dia. Taper Pin, 3/8" long
89	120X.113	Roller Pin
90	120X.114	Roller

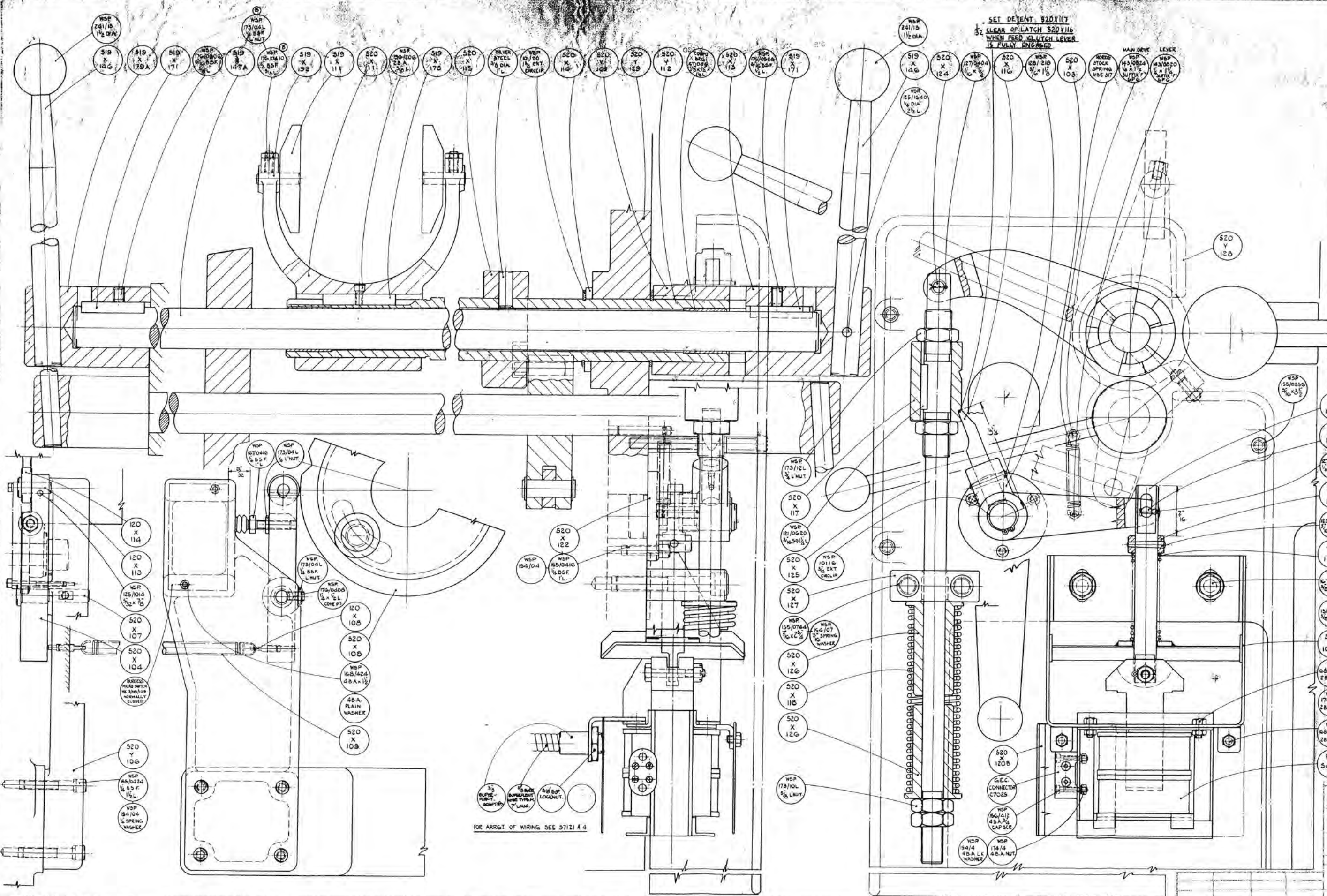

FIRST USED ON
1031.
LAST USED ON BATCH
SUPERSEDED BY
520Z1 AFTER 316.
SUPERSEDED BY
ALTERATIONS
ISSUE 6875 43-4

REMOVE ALL SHARP
CORNERS, UNLESS
OTHERWISE STATED
TOLERANCE ON
MACHINING DIMENSIONS
±.010 UNLESS
OTHERWISE STATED
AMERICAN
PROJECTION
F - ROUGH
FF - FINISH MACHINE
FFF - GRIND OR
EQUIVALENT
MARK DRG. NO. AT

Wickman
MACHINE TOOL DIVISION
COVENTRY, ENGLAND.

DESCRIPTION
AUTOMATIC STOP.
COPYRIGHT

SCALE	DRAWN	DC F	3-7-50	PARTS LISTS
FULL	UNCHECKED			520Z1/2/3/4/5
SIZE	TRACED	W.H	2-1-52.	

NO. 520Z1
ISSUE 6875
31-10-50
1-1-52

ORG. NO.
520Z1A.

BAR FEED - DRAWING NO. 558 Z 1C

<u>INDEX</u> <u>NO.</u>	<u>PART</u> <u>NO.</u>	<u>TITLE</u>
1	558X.113	Stop Collar
2	125/4064	5/8" Taper Pin, 4" long.
3	58X.115	Washer
4	558V.105C	Bar Feed Pusher Rod.
5	182/0616	5/8" B.S.F. Socket Head Screw, Taper Point 1" long
6	126/1218	3/8" Parallel Hardened Pin 1.1/8" long
7	558X.138	Pillar
8	558X.136	Modified Purefoy Handnut.
9	-	3/8" B.S. Whitworth Hexagon Locknut
10	558X.139	Swing Bolt
11	558Y.131A	Bar Feed Slide (1.3/4" 8-Spindle)
12	558Y.102A	Feed Tube Return Ring
13	558X.106A	Sleeve
14	212/18	1/8" B.S.P. Grease Nipple
15	210/2525	Indicator Washer
16	154/08	1/2" Spring Washer
17	155/0828	1/2" Socket Head Cap Screw 1.3/4" long
18	76/0405	1/4" B.S.F. Socket Head Set Screw, Cup Point 5/16" long
19	558X.110	Bush
20	176/0405	1/4" B.S.F. Socket Head Set Screw, Cup Point 5/16" long
21	558X.111	Spring Guide Rod
22	558X.121A	Collar
23	125/1628	1/4" Taper Pin 1.3/4" long
24	558X.118	Bar Feed Spring
25	558Y.116A	Spring Cover
26	558X.119A	Spring Adjusting Screw
27	58X.123A	Fulcrum Pin
28	182/0612	3/8" B.S.F. Socket Head Set Screw, Taper Point 3/4" long
29	8X.129B	Spring
30	558X.124A	Plunger
31	558Z.101C	Bar Feed Slide (2.5/8"-6 and 3.1/4"-6 Spindle)
32	558X.108	Tee Bolt
33	558Y.104A	Bar Feed Adjustable Cam Bracket
34	130/12	3/4" Washer
35	58X.122A	Cap
36	558X.112	Cam Roller
37	558X.107	Cam Roller Pin
38	125/2236	11/32" Taper Pin 2.1/4" long
39	173/12	3/4" B.S.F. Hexagon Nut
40	58X.120A	Nut
41	155/0406	1/4" B.S.F. Socket Head Cap Screw, 3/8" long
42	155/0820	1/2" B.S.F. Socket Head Cap Screw 1.1/4" long
43	154/08	1/2" Spring Washer
44	558X.117A	Spring Cover Flange
45	522Z.102	Stock Carriage Indexing Bracket
46	165/206 BL	2 B.A. Round Head Screw 3/8" long
47	558X.109	Bar Feed Scale (English)
48	212/18	1/8" B.S.P. Grease Nipple
49	210/2525	Indicator Washer
50	154/05	5/16" Spring Washer
51	155/0508	5/16" Socket Head Cap Screw 1/2" long
52	558X.110	Bush

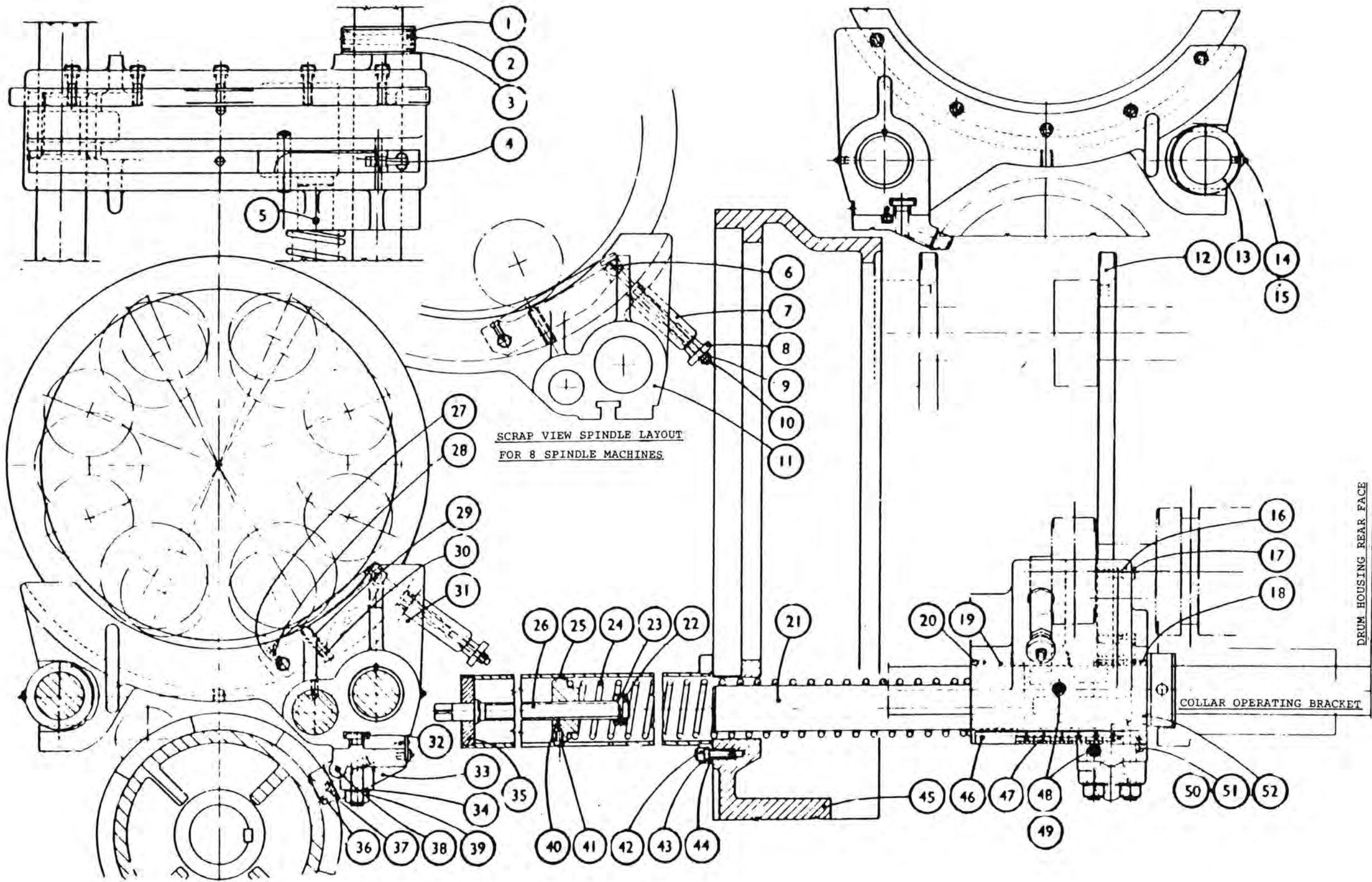

BAR FEED TRIP- DRAWING NO. 553 Y 1A

<u>INDEX</u> <u>NO.</u>	<u>PART</u> <u>NO.</u>	<u>TITLE</u>
1	AW12-B1	Square D Limit Switch, Class 9007
2	156/224	2 B.A. Socket Head Cap Screw 1.1/2" long
3	154/03	Spring Washer
4	553X.104	Switch Bracket
5	173/06L	3/8" B.S.F. Hexagon Locknut
6	188X.108	Trip Clamp
7	195/0512	5/16" B.S.F. Square Head Screw 3/4" long
8	553X.105	Pusher Bracket
9	167/0412	1/4" B.S.F. Hexagon Head Set Screw 3/4" long
10	198/8	Lockwasher
11	553X.106	Trip Rod
12	167/0412	1/4" B.S.F. Hexagon Head Set Screw 3/4" long.
13	198/8	Lockwasher
14	MSC173	Compression Spring

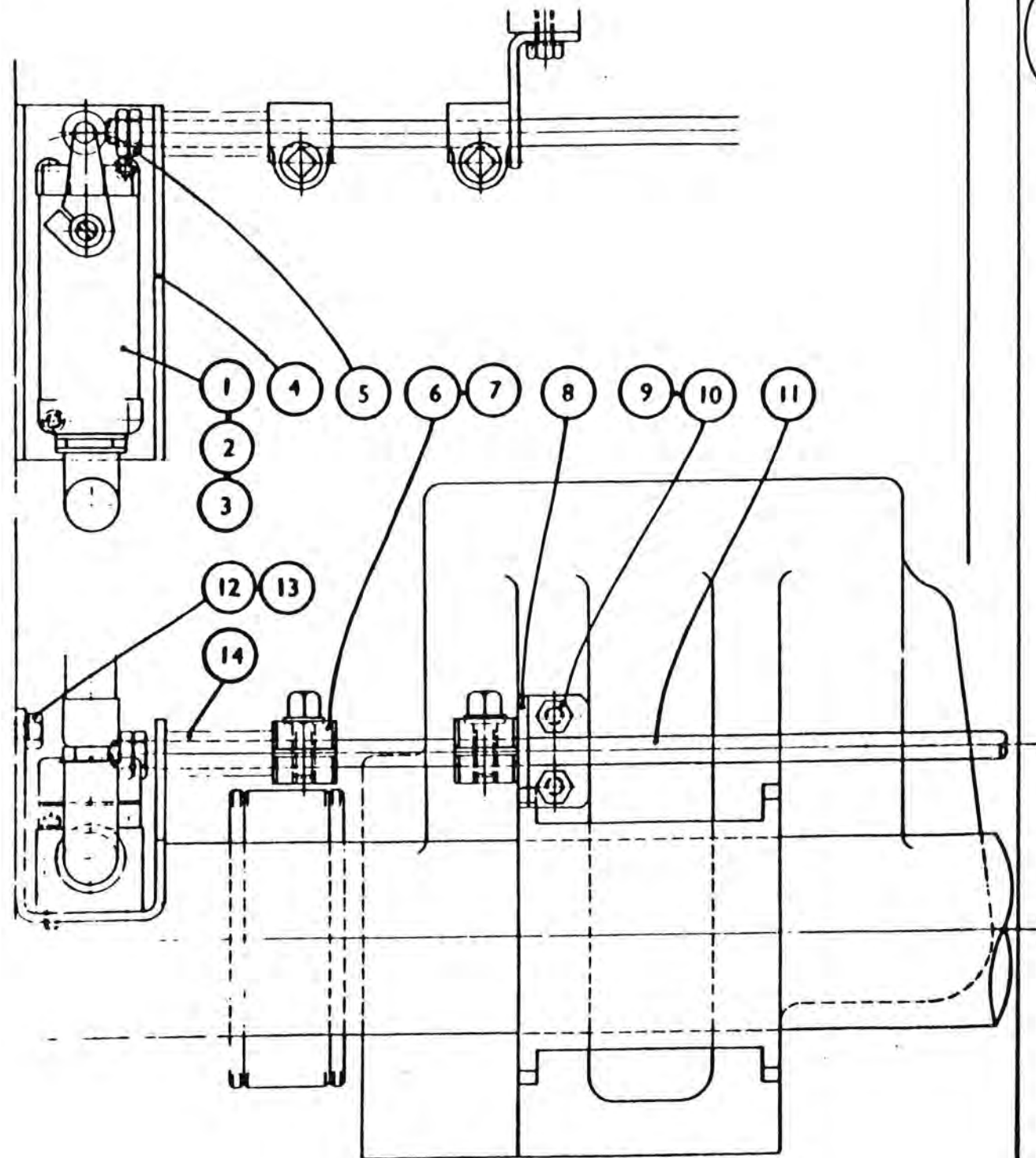

VIEW IN DIRECTION OF ARROW

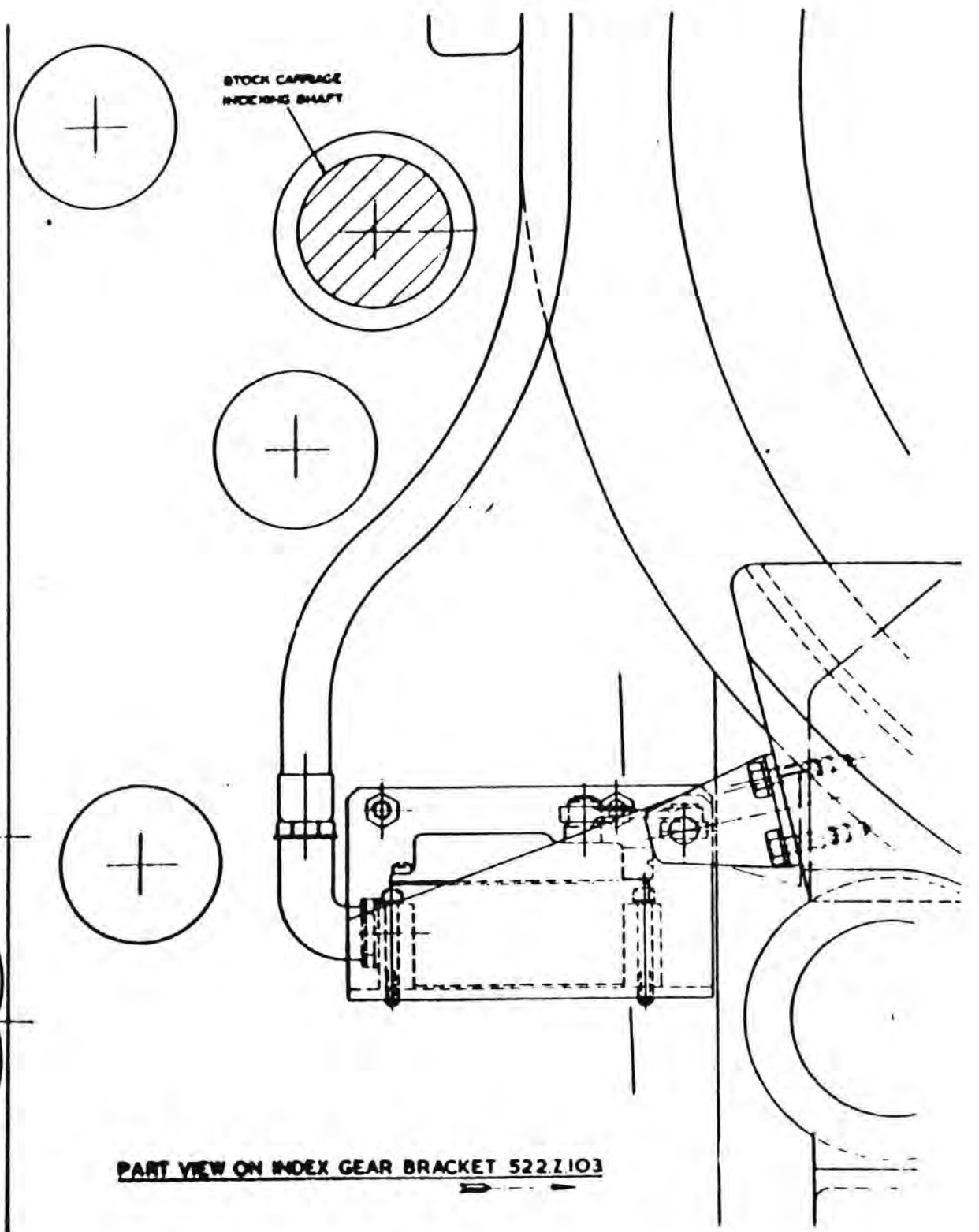

PART VIEW ON INDEX GEAR BRACKET 522.2103

BAR STOP and OPERATING MECHANISM - DRAWING NO. 550 Z 1B

<u>INDEX</u> <u>NO.</u>	<u>PART</u> <u>NO.</u>	<u>TITLE</u>
1	154/06	3/8" Spring Washer
2	155/0620	3/8" B.S.F. Socket Head Cap Screw 1.1/4" long
3	154/07	7/16" Spring Washer
4	155/0724	7/16" B.S.F. Socket Head Cap Screw 1.1/2" long
5	550Z.201	Bar Stop Cover (1.3/4"-8 Spindle).
6	550Z.101A	Bar Stop Cover (2.5/8"-6 Spindle and 3.1/4"-6 Spindle)
7	155/0696	3/8" B.S.F. Socket Head Cap Screw 6" long.
8	154/06	3/8" Spring Washer
9	139/11	11/32" Headed Taper Pin 2" long
10	550Y.110B	Bracket for Bar Stop Shaft
11	550V.115B	Bar Stop Operating Crank
12	155/0820	1/2" B.S.F. Socket Head Cap Screed 1.1/4" long
13	550X.120A	Link Pin
14	101/15	1.1/4" External Circlip
15	155/0620	3/8" B.S.F. Socket Head Cap Screw 1.1/4" long
16	154/06	3/8" Spring Washer
17	50X.136	Screw Locking Nut
18	125/1220	3/16" Taper Pin 1.1/4" long.
19	550X.135	Adjusting Nut
20	550X.133	Retaining Washer
21	550X.140	Link Rod
22	550Y.130	Spring Housing
23	550X.132	Compression Spring
24	550X.134	Spring Seat
25	550X.137	Spring Retaining Nut
26	127/0814	1/8" Split Cotter Pin 1.3/4" long
27	550Z.102A	Bar Stop Cover (2.5/8"-6 spindle and 3.1/4"-6 Spindle)
28	550Z.202	Bar Stop Cover (1.3/4"-8 Spindle)
29	155/0828	1/2" B.S.F. Socket Head Cap Screw 1.1/4" long
30	154/08	1/2" Spring Washer
31	210/2525	Indicator Washer, Yellow
32	212/18	1/8" B.S.P. Grease Nipple
33	550Y.112A	Bar Stop Shaft
34	550Y.113A	Adjusting Sleeve
35	550Z.1088	Bar Stop Bracket
36	122/2056T	Key. Tapped
37	550X.127	Locknut
38	550X.114	Lockating Pin
39	550X.203	Shaft Cover (1.3/4"-8 spindle)
40	550X.103A	Shaft Cover (2.5/8"-6 and 3.1/4"-6 spindle)
41	236/242820	Oil Retaining Bush 1.1/2" x 1.3/4" x 1.1/2" long
42	101/18	1.1/2" External Circlip
43	550X.126A	Adjusting Washer
44	173/05	5/16" B.S.F. Nut
45	176/0536	5/16" Socket Head Set Sscrw Cup Point 2.1/4" long
46	550X.150A	Stop Carrier
47	188/0632	3/8" B.S.F. Square Headed Set Sscres 2" long
48	173/06	3/8" B.S.F. Nut
49	158/0412	1/4" B.S.F. Countersunk Socket Head Screw 1.3/4" long
50	550Y.143A	Oil Seal Cap.
51	235/7292B	Oil Seal 4.1/2" x 5.3/4" x 5/8" long

BAR STOP and OPERATING MECHANISM - DRAWING NO. 550 Z 1B

<u>INDEX</u> <u>NO.</u>	<u>PART</u> <u>NO.</u>	<u>TITLE</u>
52	155/0516	5/16" B.S.F. Socket Head Cap Screw 1" long
53	154/05	5/16" Spring Washer
54		
55		
56	50X.204	Bar Stop (1.3/4"-8 spindle)
57	550X.148	Bar Stop for Lower Position (2.5/8"-6 and 3.1/4"-6 spindle).
58	550Y.111A	Bracket (Drum Housing End)
59	139/11	11/32" Square Headed Taper Pin 2" long
60	155/0724	7/16" B.S.F. Socket Head Cap Screw 1.1/2" long
61	154/07	7/16" Spring Lockwasher
62	101/6	3/4" External Circlip
63	550X.138	Pin
64	154/05	5/16" Spring Washer
65	155/0516	5/16" B.S.F. Socket Head Cap Screw 1" long
66	550X.105B	Fulcrum Pin
67	550X.107A	Roller Pin
68	550X.106A	Cam Roller
69	125/1632	1/4" Taper Pin, 2" long.
70	550Y.104Y	Cam Lever
71	236/242824	Oil Retaining Bush 1.1/2" x 1.3/4" x 1.1/2" long

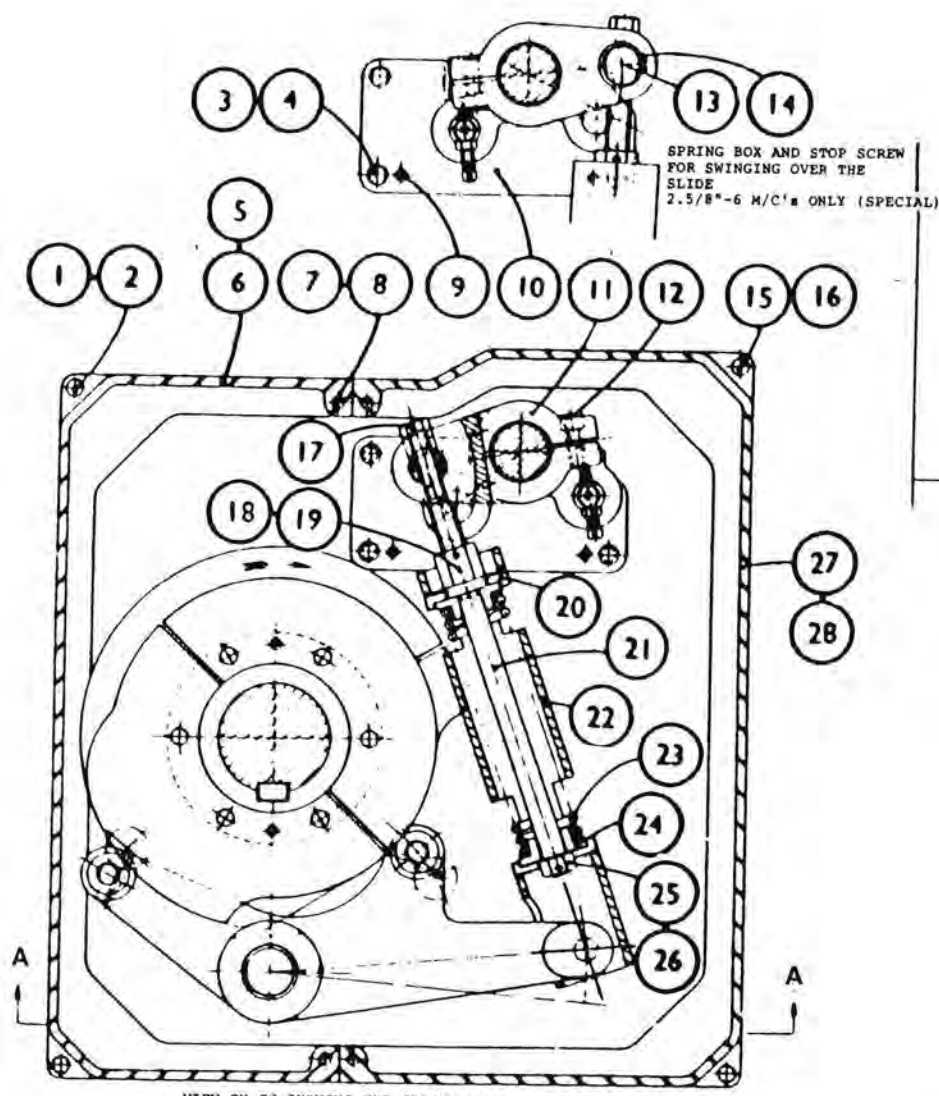

SPRING BOX AND STOP SCREW
FOR SWINGING OVER THE
SLIDE
2.5/8"-6 H/C" ONLY (SPECIAL)

VIEW ON CC SHOWING THE SPRING BOX
AND STOP SCREW
SET FOR THE STANDARD LOW POSITION WORKING

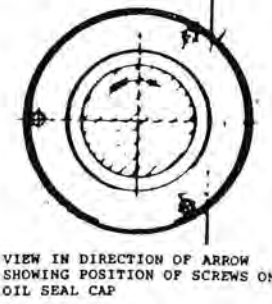
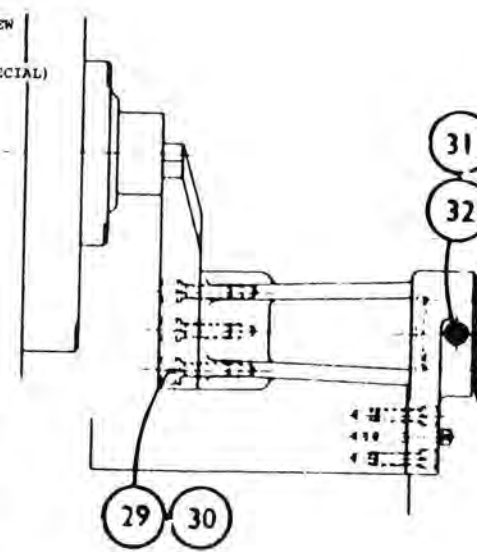

VIEW IN DIRECTION OF ARROW
SHOWING POSITION OF SCREWS ON
OIL SEAL CAP

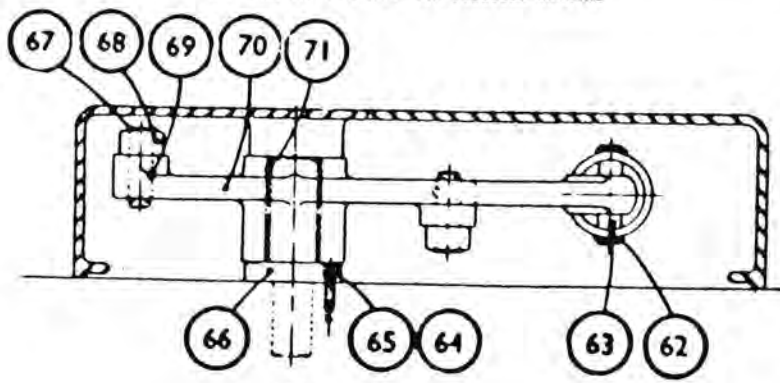
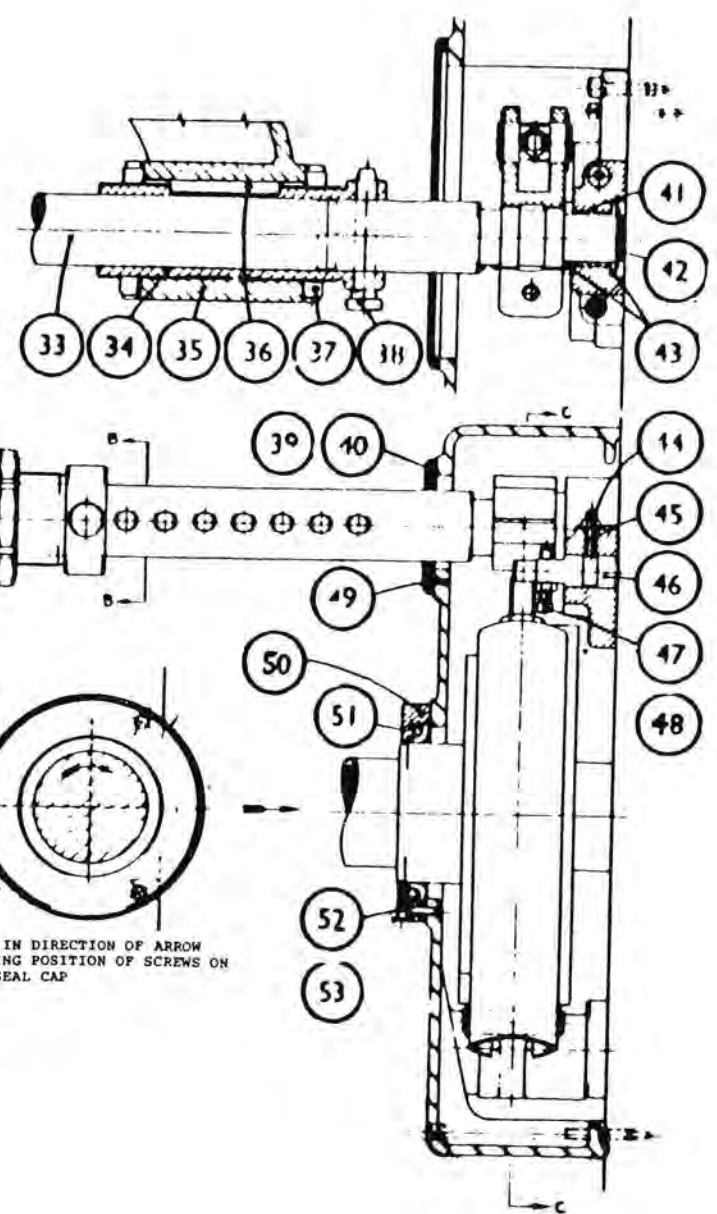

VIEW ON 'AA'
SHOWING CAM LEVER

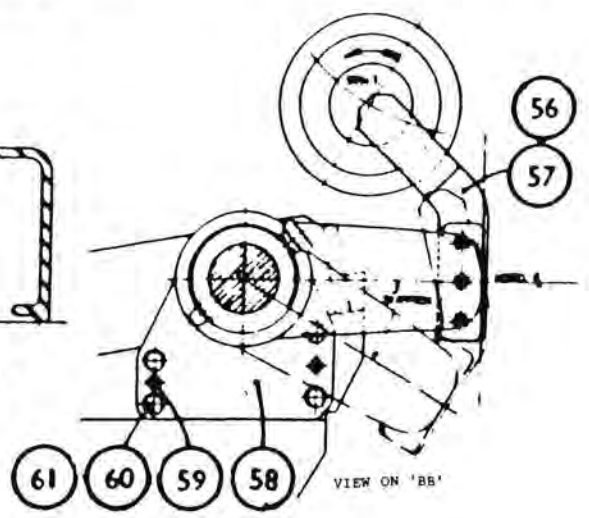

VIEW ON 'BB'

BAR STOP and OPERATING MECHANISM - DRAWING NO. 550 Z 1C

<u>INDEX</u> <u>NO.</u>	<u>PART</u> <u>NO.</u>	<u>TITLE</u>
1	154/07	Lockwasher
2	155/0724	7/16" B.S.F. Hexagon Socket Cap Screw 1.1/2" long
3	139/11	11/32" dia. Square Head Taper Pin 2" long
4	550Y.110B	Bracket
5	550X.120A	Link Pin
6	101/15	1/4" dia. External Circlip
7	154/06	3/8" Spring Lockwasher
8	155/0620	3/8" B.S.F. Hexagon Socket Cap Screw 1.1/4" long
9	550Z.201	Bar Stop Cover (1.3/4"-8)
10	550Z.101A	Bar Stop Cover 2.5/8"-6, 3.1/4"-6, 3.1/2"-4, 4.1/8"-4)
11	155/0696	3/8" B.S.F. Hexagon Socket Cap Screw 6" long
12	154/06	3/8" Spring Lockwasher
13	550V.115C	Bar Stop Operating Crank
14	155/0820	1/2" B.S.F. Hexagon Socket Cap Screw 1.1/4" long
15	155/0620	3/8" B.S.F. Hexagon Socket Cap Screw 1.1/4" long
16	154/06	3/8" Spring Lockwasher
17	550X.136	Screw Locking Nut
18	125/1220	3/16" dia. Taper Pin 1.1/4" long
19	550X.135	Adjusting Nut
20	550Z.102A	Bar Stop Cover (2.5/8"-6, 3.1/4"-6, 3.1/2"-4, 4.1/8"-4)
21	550Z.202	Bar Stop Cover (1.3/4"-8)
22	550X.133	Retaining Washer
23	550X.140	Link Rod
24	550Y.130	Spring Housing
25	550X.132	Compression Spring
26	550X.134	Spring Seat
27	550X.137	Spring Retaining Nut
28	127/0814	1/8" dia. Split Cotter Pin 1.3/4" long
29	550X.107A	Roller Pin
30	550X.106A	Cam Roller
31	125/1632	1/4" dia. Taper Pin 2" long
32	550Y.104B	Cam Lever
33	236/242824	Oil Retaining Bush 1.1/2" x 1.3/4" x 1.1/2"
34	550X.105B	Fulcrum Pin
35	155/0516	5/16" B.S.F. Hexagon Socket Cap Screw 1" long
36	154/05	5/16" Spring Lockwasher
37	550X.138	Pin
38	101/6	3/4" dia. External Circlip
39	154/07	7/16" Spring Lockwasher
40	155/0724	7/16" B.S.F. Hexagon Socket Cap Screw 1.1/2" long
41	550Y.111A	Bracket
42	139/11	11/32" Square Head Taper Pin 2" long
43	195/1040	5/8" dia. B.S.F. Collar Screw 2.1/2" long
44	203/08	1/2" B.S.F. Self Locking Nut
45	188/0864	1/2" B.S.F. Square Head Set Screw 4" long
46	550X.148A	Bar Stop (Lower Position)
47	550X.108C	Bar Stop Bracket
48	210/2525	Yellow Indicator Washer
49	212/18	1/8" B.S.P. Hexagon Nipple
50	550X.114	Locating Pin
51	550Y.112B	Bar Stop Shaft
52	550X.203	Shaft Cover (1.3/4"-8)

BAR STOP and OPERATING MECHANISM - DRAWING NO. 550 Z 1C

<u>INDEX NO.</u>	<u>PART NO.</u>	<u>TITLE</u>
53	550X.103A	Shaft Cover (2.5/8"-6, 3.1/4"-6, 3.1/2"-4, 4.1/8"-4)
54	236/242824	Oil Retaining Bush 1.1/2" x 1.3/4" x 1.1/2"
55	101/18	1.1/2" dia. External Circlip
56	550X.126A	Adjusting Washer
57	173/05	5/16" B.S.F. Hexagon Nut
58	176/0536	5/16" B.S.F. Hexagon Socket Set Screw Cup Point 2.1/4" long
59	550X.150A	Stop Carrier
60	188/0632	3/8" B.S.F. Square Head Set Screw 2" long
61	173/06	3/8" B.S.F. Hexagon Nut
62	158/0412	1/4" B.S.F. Hexagon Socket Countersunk Head Screw 3/4" long
63	550Y.143A	Oil Seal Cap
64	235/7292B	Oil Seal 4.1/2" Bore
65	155/0516	5/16" B.S.F. Hexagon Socket Cap Screw 1" long.
66	154/05	5/16" Spring Lockwasher

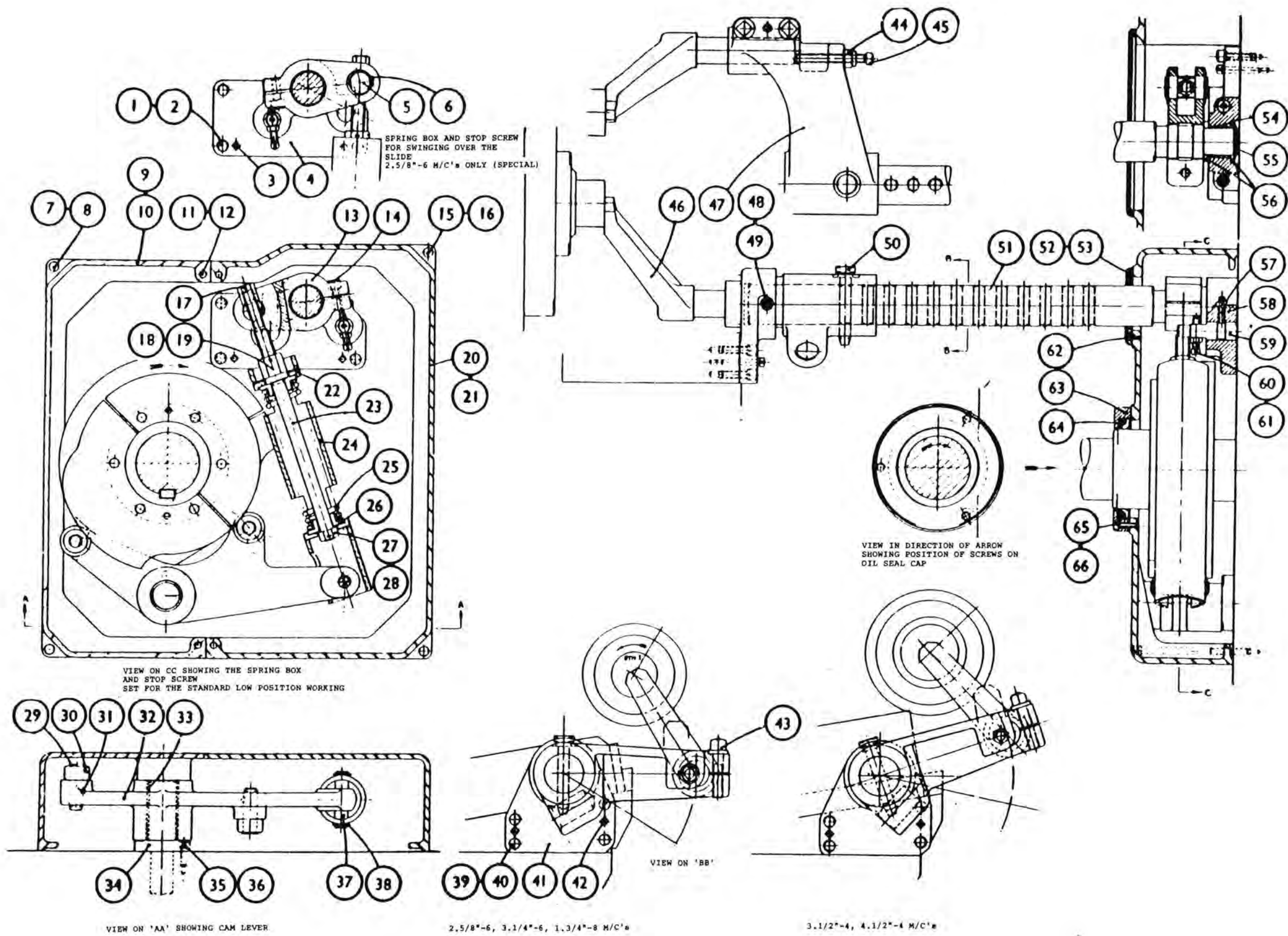

CHAIN DRIVES - DRAWING NO. 517 Z 2A

<u>INDEX</u> <u>NO.</u>	<u>PART</u> <u>NO.</u>	<u>TITLE</u>
1	236/162024	Oil Retaining Bush, 1" bore x 1.1/4" o/d x 1.1/2" long
2	--	Renold 21T 1/2"P. Duplex No. 212609, 1.1/4" bore
3	518X.163	Jockey Eccentric
4	518X.197	Collar for Jockey Sprockets
5	203/12L	3/4" B.S.F. Pinnacle Nut, NT/F.244
6	528X.169	Jockey Sprocket
7	236/162024	Oil Retaining Bush, 1" bore x 1.1/4" o/d x 1.1/2" long
8	203/12L	3/4" B.S.F. Pinnacle Nut, NT/F.244
9	518X.197	Collar for Jockey Sprockets
10	518X.163	Jockey Eccentric
11	154/2	2 B.A. Spring Steel Washer
12	156/208	2 B.A. Socket Head Cap Screw
13	167/0640	3/8" B.S.F. Hexagon Head Set Screw, 2.1/2" long
14	519X.172	Key for Sliding Gear
15	128/6C.	Pad Bush 1" long (Plain Part)
16	128/6T	Pad Bush 1" long (Threaded Part)
17	568X.126	Pump Jockey Pillar
18	568X.125	Pump Jockey Arm
19	568X.127	Washer
20	170/1060	5/8" B.S.F. Hexagon Head Bolt 3.1/2" long
21	518X.162	Jockey Pin
22	236/162018	Oil Retaining Bush, 1" bore x 1.1/4" o/d x 1.1/4" long
23	---	Reynold 19T. 1/2P. No. 212461. 1.1/4" bore

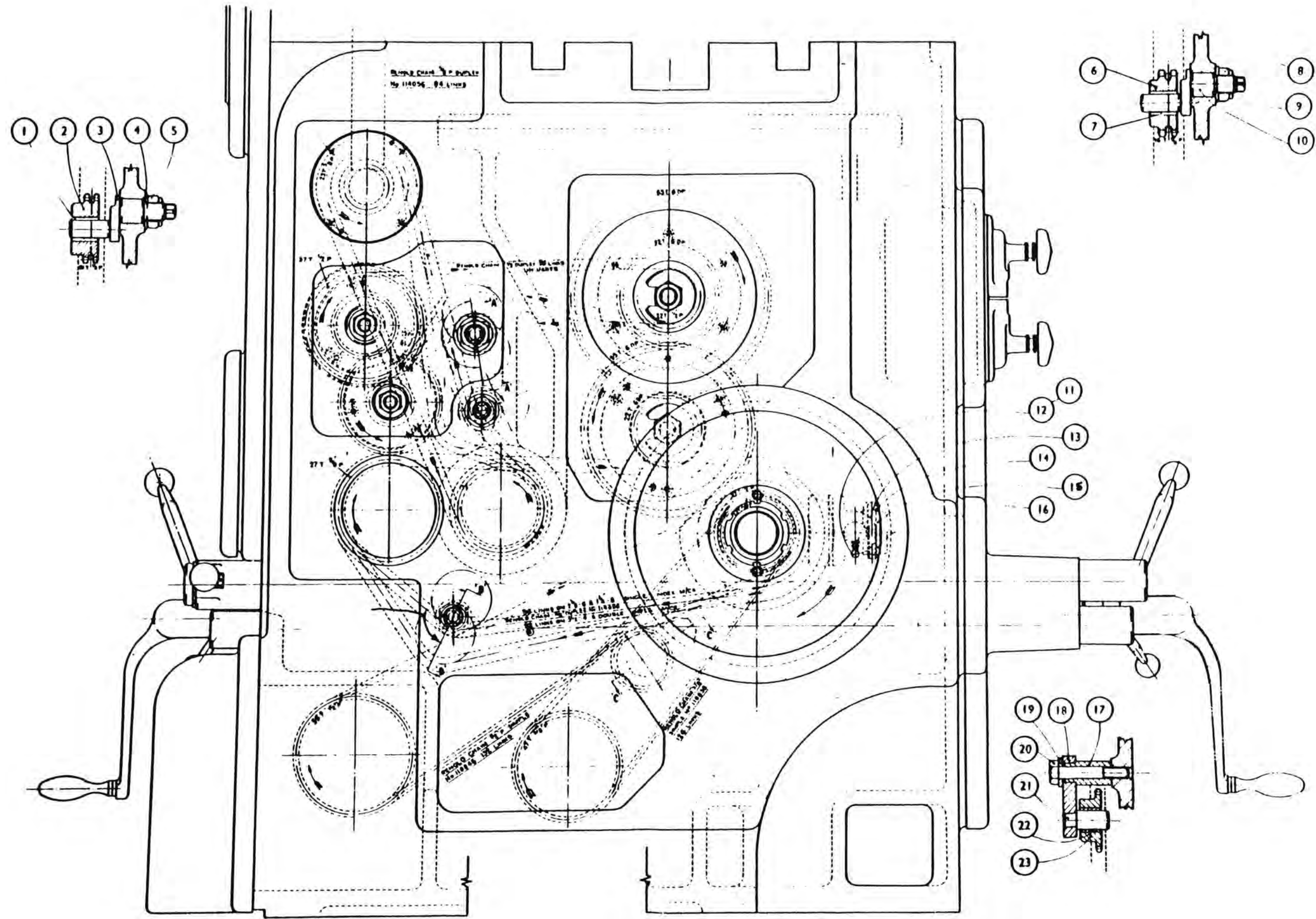

COLLET OPERATION - DRAWING NO. 556 Z 1

<u>INDEX</u> <u>NO.</u>	<u>PART</u> <u>NO.</u>	<u>TITLE</u>
1	556Y.103A	Collet Operation Lever Bracket
2	155/0824	1/2" B.S.F. Socket Head Cap Screw 1.1/2" long
3	178/0508	5/16" B.S.F. Socket Set Screw, Half-Dog 1/2" long
4	556X.110	Fulcrum Pin
5	558X.113	Stop Collar
6	556Z.101	Collet Operating Slide
7	212/18	1/8" B.S.P. Grease Nipple
8	210/2525	Yellow Washer, 25/64" hole
9	558X.106A	Sleeve
10	556Y.113	Collet Closing Finger
11	126/1044	5/16" Parallel Pin, 2.3/4" long
12	202428	Oil-Retaining Bush
13	101/15	1.1/4" External Circlip
14	210/2525	Yellow Washer 25/64" hole
15	212/18	1/8" B.S.P. Grease Nipple
16	556Y.104A	Collet Operating Lever Swivel
17	556Y.105A	Collet Operating Lever
18	573X.112	Collet Operating Lever
19	556X.109	Swivel Pin
20	556X.110	Fulcrum Pin
21	178/0508	5/16" B.S.F. Socket Set Screw, Half-Dog, 1/2" long
22	556X.111A	Plunger
23	556X.112B	Plunger Spring
24	212/18	1/8" B.S.P. Grease Nipple
25	210/2525	Yellow Washer 25/64" hole
26	556X.106	Cam Roller Sleeve
27	556Y.102	Collet Operation Cam Roller Bracket
28	139/13	3/8" Headed Taper Pin 1.1/2" long
29	178/0614	3/8" B.S.F. Socket Set Screw, Half-Dog, 7/8" long
30	173/06	3/8" B.S.F. Hexagon Nut
31	125/2224	11/32" Taper Pin, 1.1/2" long.
32	558X.107	Cam Roller Pin
33	558X.112	Cam Roller
34	173/08L	1/2" B.S.F. Hexagon Locknuts
35	556X.117	Stop Rod
36	176/0405	1/4" B.S.F. Socket Set Screw 5/16" long
37	558X.110	Bush
38	128/8C	Plain Pad Bush
39	155/0848	1/2" B.S.F. Socket Head Cap Screw 3" long
40	128/8T	Threaded Pad Bush
41	155/0864	1/2" B.S.F. Socket Head Cap Screw 4" long
42	154/08	1/2" Spring Washer
43	212/18	1/8" B.S.P. Grease Nipple
44	210/2525	Yellow Washer 25/64" hole
45	558X.110	Bush
46	176/0405	1/4" B.S.F. Socket Set Screw, 5/16" long
47	558X.115	Washer

**Refer to drawing
showing all part
numbers**

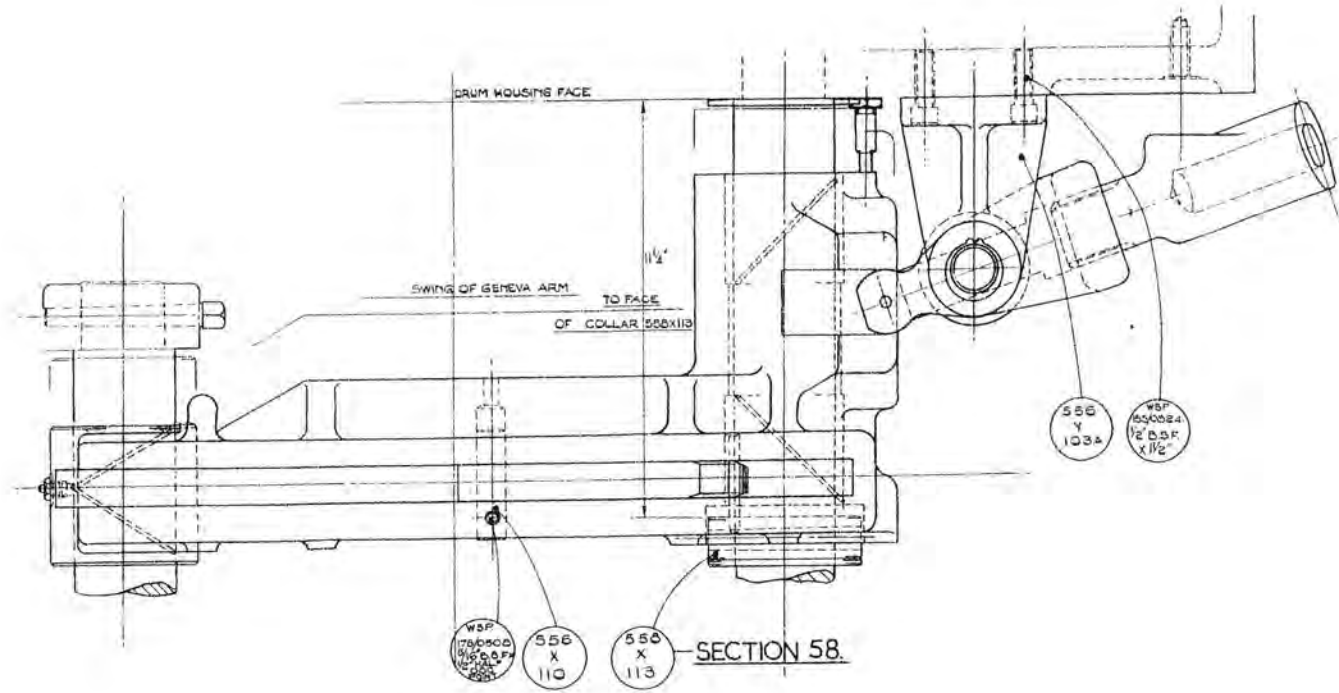

- (A) ALTERED N° 14051
- (B) P.L.T. 500 P. 145
ERS. 19.3.53
- (C) 500A 358
M.B.W. 21.7.53
- (D) 500M 55 NL 52 42
75
- (E) 500A 503 27.5.45

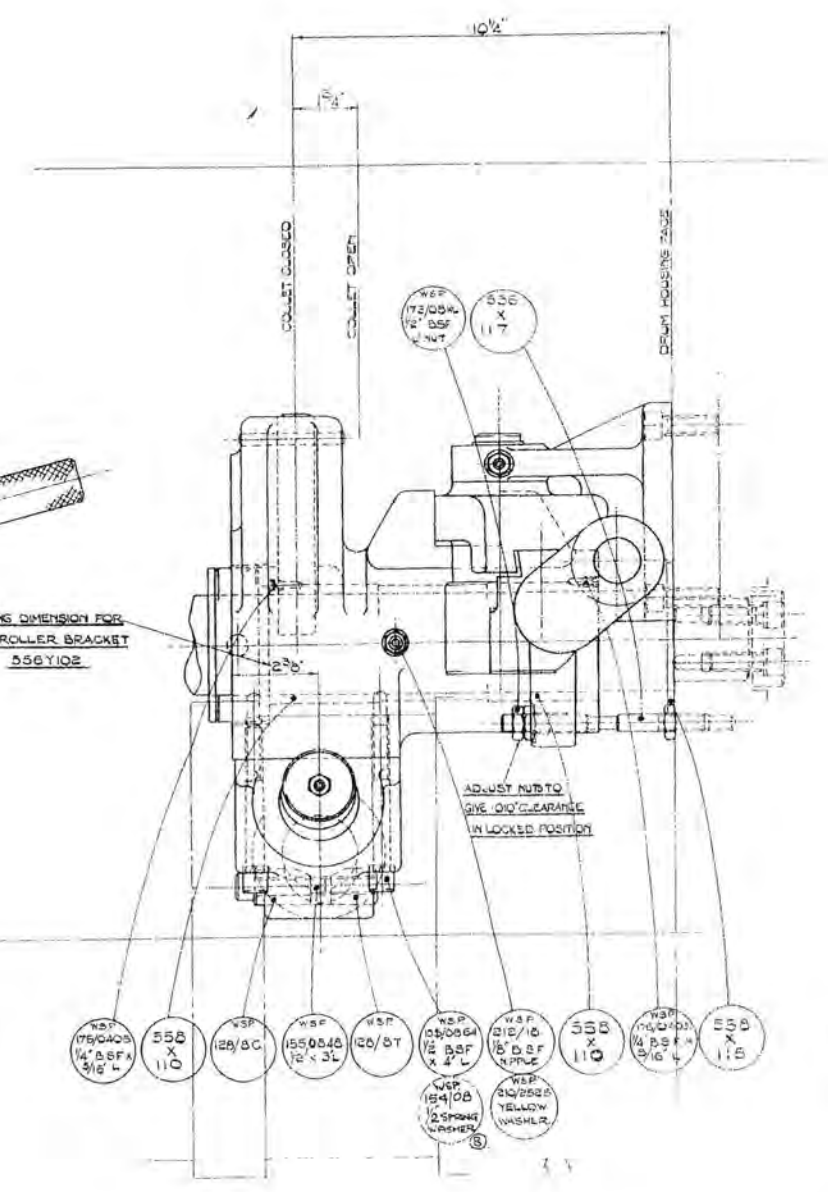
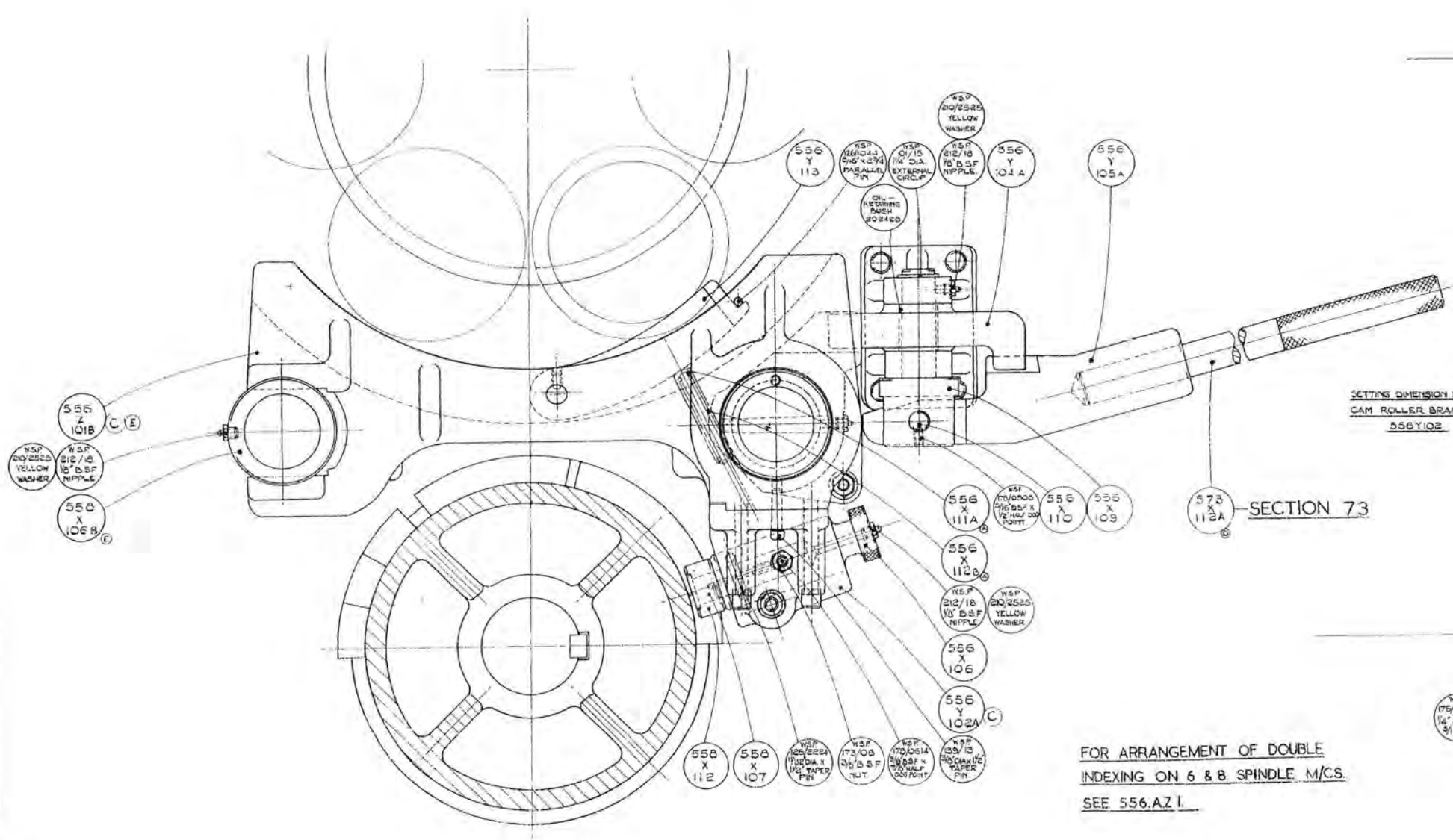

FOR ARRANGEMENT OF DOUBLE INDEXING ON 6 & 8 SPINDLE M/C'S. SEE 556.AZ.I.

CONTROLS - - DRAWING NO. 519 Z 2A

<u>INDEX</u> <u>NO.</u>	<u>PART</u> <u>NO.</u>	<u>TITLE</u>
1	519X.114A	Handwind Thrust Bearing
2	125/2240	Taper Pin 11/32" dia. 2.1/2" long
3	519X.150A	Handwind Thrust Block
4	155/0524	5/16" B.S.F. Socket Head Cap Screw, 1.1/2" long
5	210/2525	Yellow Washer
6	212/18	1/8" B.S.P. Autolub Nipple
7	176/0505	5/16" B.S.F. Socket Set Screw 5/16" long
8	519X.171	ver Boss Key
9	241/9	1/8" B.S.F. Bakelite Knob 1.1/4" dia.
10	519X.151	Handwind Engage Lever
11	182/0512	5/16" B.S.F. Hexagon Socket Set Screw, taper point 3/4" long
12	519X.180A	Handwide Engage Boss
13	519X.179A	Lever Boss
14	182/0612	3/8" B.S.F. Hexagon Socket Set Screw, taper point 3/4" long
15	519X.146	Feed Lever
16	241/13	1/8" B.S.F. Bakelite Knob 1.1/2" dia.
17	519X.171	Lever Boss Key
18	176/0506	5/16" B.S.F. Socket Set Screw, 3/8" long
19	212/18	1/8" B.S.P. Autolub Nipple
20	210/2525	Yellow Washer
21	519Y.101A	Extension Bracket
22	125/2232	Taper Pin 11/32" dia. 2" long
23	519X.192	Glut Pin
24	176/0410	1/4" B.S.F. Socket Set Screw, cup Point 5/8" long
25	519X.111	Glut
26	519Y.126B	Glut Lever
27	173/04L	1/4" B.S.F. Hexagon Locknut
28	125/1220	Taper Pin 3/16" dia. 1.1/4" long
29	519X.127	Glut Lever Roller
30	519X.128	Glut Lever Roller Pin
31	182/0512	5/16" B.S.F. Hexagon Socket Set Screw, taper point 1/4" long
32	173/05L	5/16" B.S.F. Hexagon Locknut
33	179/204	2 B.A. Socket Set Screw, 1/4" long
34	153X.111	Plunger
35	153X.118A	Plunger Spring
36	519X.186	Pivot Pin
37	519X.185	Cover Plate
38	519X.184A	Fast Motion Lever Boss
39	164/0408	1/4" B.S.F. Round Head Screw, 1/2" long
40	101/13	External Circlip 1.1/8" dia.
41	154/05	5/16" dia. Spring Washer
42	155/0506	5/16" B.S.F. Socket Head Cap Screw 3/8" long
43	519X.160A	Fast Motion Lever
44	519X.146	Feed Lever
45	519X.171	Lever Boss Key
46	519X.162A	Collar
47	519X.161A	Fast Motion Lever Shaft
48	156/208	2 B.A. Socket Head Cap Screw, 1/2" long
49	154/2	2 B.A. Spring Washer
50	519X.172	Key for Sliding Gear
51	173/04L	1/4" B.S.F. Hexagon Locknut

CONTROLS - DRAWING NO. 519 Z 2A

<u>INDEX</u> <u>NO.</u>	<u>PART</u> <u>NO.</u>	<u>TITLE</u>
52	519X.111	Glut
53	176/0410	1/4" B.S.F. Hexagon Set Screw, Cup Point 5/8" long
54	519X.192	Glut Pin
55	519X.147A	Feed Lever Shaft
56	519X.180A	Handwind Engage BOss
57	182/0512	5/16" B.S.F. Hexagon Socket Set Screw, taper point 3/4" long
58	519X.151	Handwind Engage Lever
59	519X.171	Lever Boss Key
60	176/0505	5/16" B.S.F. Socket Set Screw 5/16" long
61	519X.169	Lever Spacer
62	519X.144	Link Pin
63	101/2	External Circlip 1/2" dia.
64	519X.122A	Handwind and Interlock Lever
65	182/0614	3/8" B.S.F. Socket Set Screw, taper point 7/8" long
66	173/06	3/8" B.S.F. Hexagon Nut
67	519X.181B	Interlock Pin
68	519X.152A	Handwind Engage Shaft
69	519X.167	Handwind Drive
70	125/2232	Taper Pin 11/32" dia. 2" long
71	519X.113A	Bush
72	519X.148	Screw
73	182/0616	3/8" B.S.F. Socket Set Screw, Taper Point 1" long
74	173/06L	3/8" B.S.F. Hexagon Locknut
75	519X.113A	Bush
76	125/2232	Taper Pin 11/32" dia. 2" long
77	519X.187A	Handwind Bevel Pinion
78	19X.149A	Handwind Shaft.

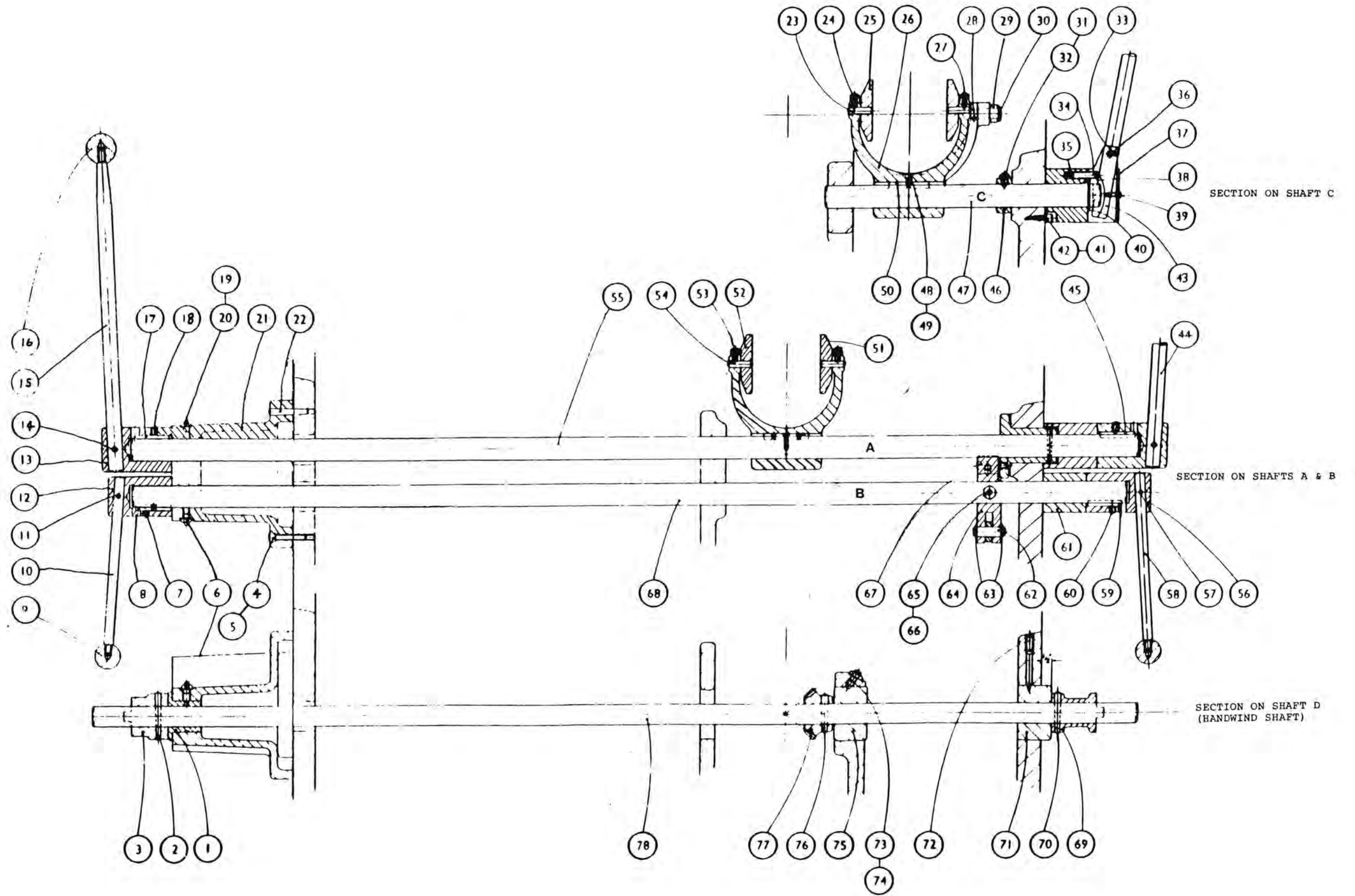

519Z2A

CONTROLS - DRAWING NO. 519 Z 1A

<u>INDEX</u> <u>NO.</u>	<u>PART</u> <u>NO.</u>	<u>TITLE</u>
1	FY.5219A	Lever
2	519X.204	Revolving Handle
3	519X.144	Link Pin
4	125/1628	Taper Pin 1/4" dia. 1.3/4" long
5	519X.123	Lever
6	519X.154	Shaft
7	125/1628	Taper Pin 1/4" dia. 1.3/4" long
8	519X.124	Lever
9	519X.111	Glut
10	519X.192	Glut Pin
11	176/0414	1/4" B.S.F. Socket Set Screw, Cup Point 7/8" long
12	173/04L	1/4" B.S.F. Hexagon Locknut
13	101/2	1/2" dia. External Circlip
14	182/0616	3/8" B.S.F. Socket Set Screw, Taper Point 1" long
15	519X.176A	Outer T-Nut
16	154/06	3/8" dia. Spring Washer
17	155/0616	3/8" B.S.F. Socket Head Cap Screw, 1" long
18	519X.133A	Operating Lever Roller Pin
19	519X.194	Roller
20	572X.158A	Indicator Plate
21	159/406	4 B.A. Socket Countersunk Screw 3/8" long
22	572X.157A	Programme Disc
23	159/406	4 B.A. Socket Countersunk Screw 3/8" long
24	519X.175A	Lever Pivot Pin
25	101/15	1.1/4" dia. External Circlip
26	519X.131A	Feed Motion Cam
27	519X.130A	Fast Motion Cam
28	125/1220	Taper Pin 3/16" dia. 1.1/4" long
29	519Z.119A	Fast Motion Operating Lever
30	173/07L	7/16" B.S.F. Locknut
31	188/0732	2 B.S.F. Square Head Set Screw, 2" long
32	241/13 RED	Bakelite Knob, Red. 1.1/2" dia. 3/8" B.S.F.
33	173/04L	1/4" B.S.F. Hexagon Locknut
34	176/0412	1/4" B.S.F. Hexagon Socket Set Screw 3/4" long
35	241/9	Bakelite Knob, Black 1.1/4" dia. 3/8" B.S.F.
36	519X.153A	Link
37	241/13	Bakelite Knob, Black 1.1/2" dia. 3/8" B.S.F.

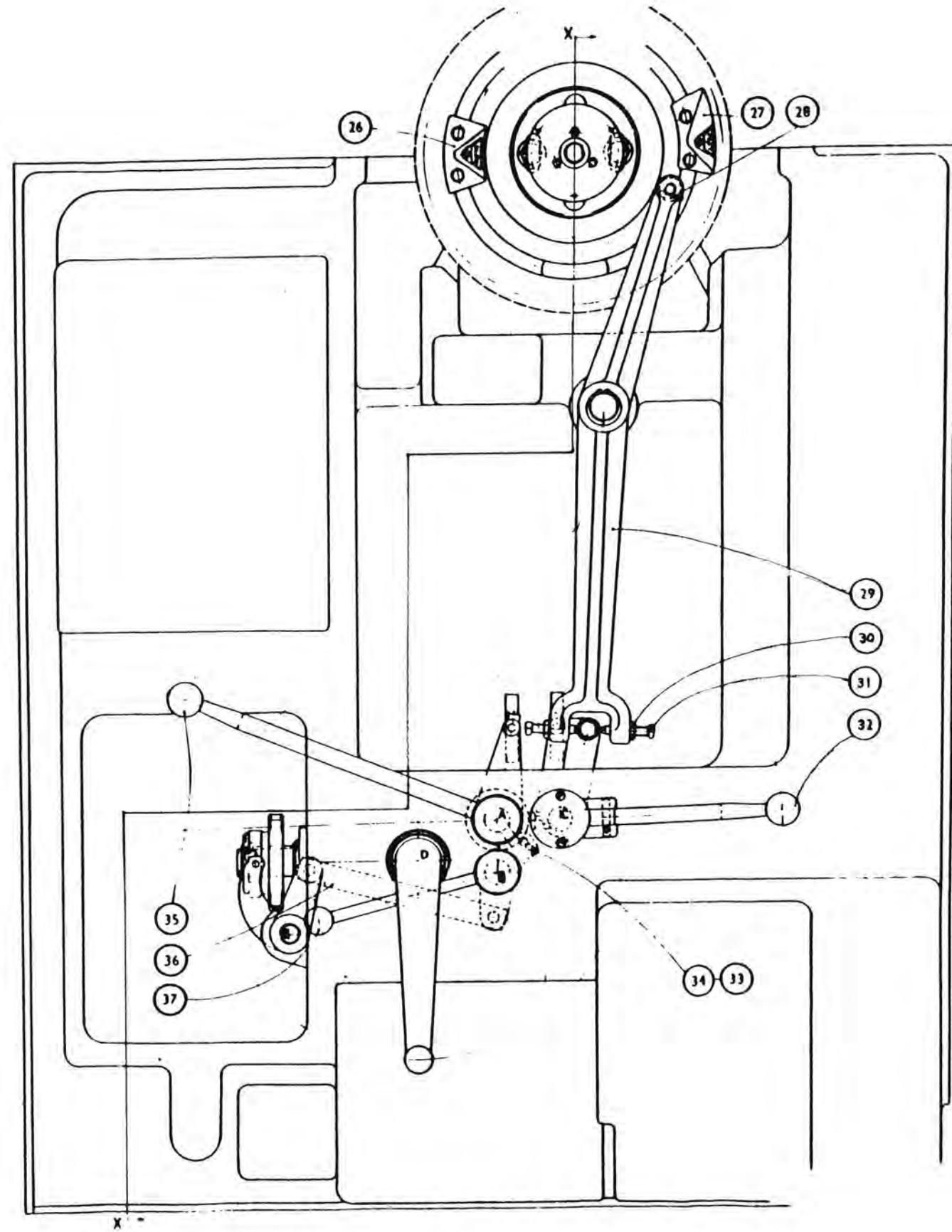
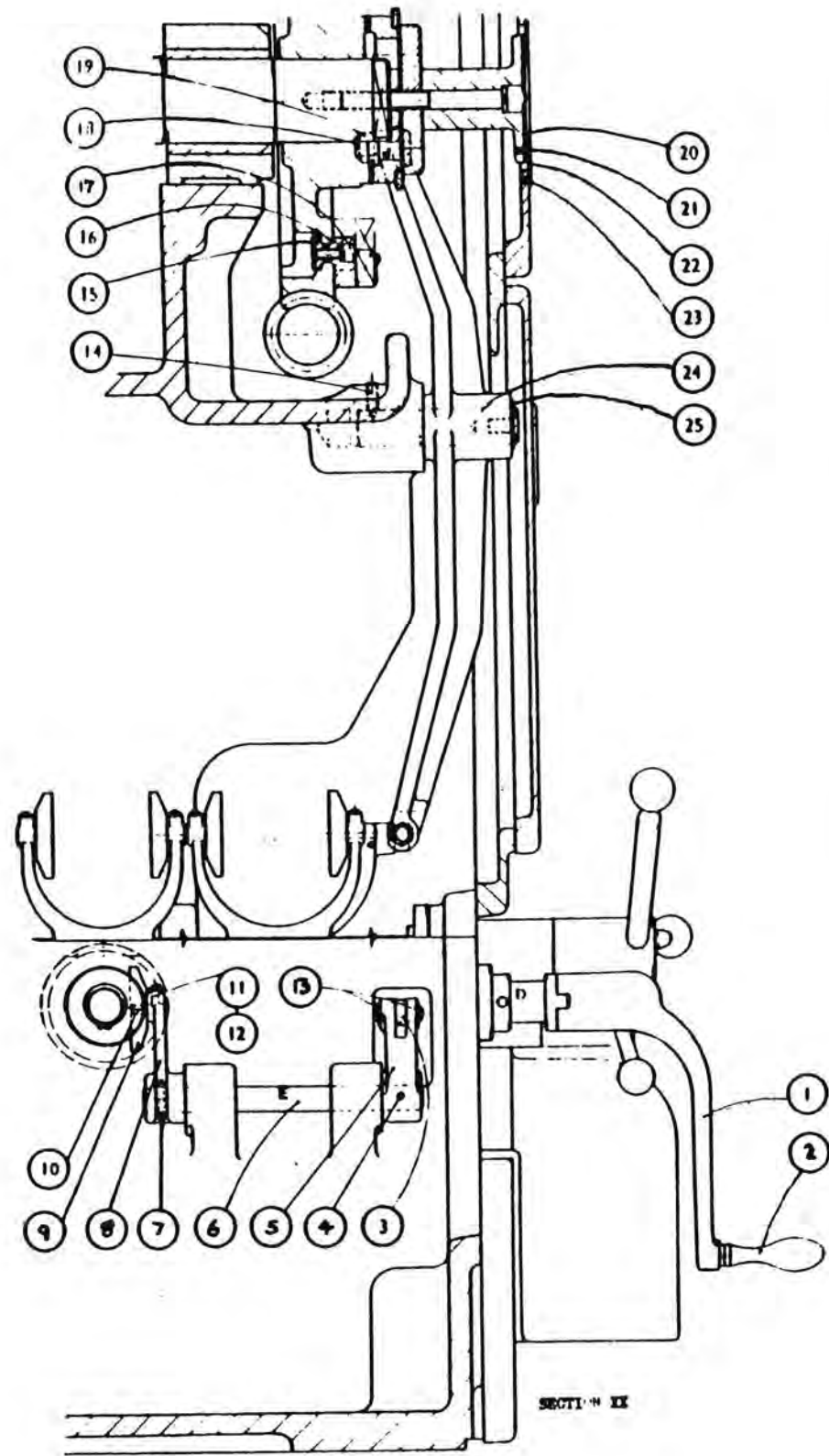

COOLANT PUMP - DRAWING NO. 569 Z 1

<u>INDEX NO.</u>	<u>PART NO.</u>	<u>TITLE</u>
1	167/0652	3/8" B.S.F. Hexagon Set Screw, 3.1/4" long
2	154/06	3/8" Spring Washer
3	154/06	3/8" Spring Washer
4	167/0620	3/8" B.S.F. Hexagon Set Screw 1.1/4" long
5	182/0412	1/4" B.S.F. Socket Set Screw, Taper Point 3/4" long
6	569X.111	Gland Locknut
7	---	Graphited Asbestos Packing 5/16" square x 1 ft. long
8	569X.112	Pump Sprocket
9	155/0516	5/16" B.S.F. Socket Head Cap Screw 1" long
10	154/05	5/16" Spring Washer
11	569X.107	Key
12	150/16	1" Standard Locknut
13	179/204	2 B.A. Set Screw. Cup Point 1/4" long
14	153/42	Soft Pad
15	569X.105	Sprocket Boss
16	569X.106	Pump Gland
17	569X.110	Gland Nut
18	569Y.102A	Coolant Pump Front Cover
19	182/0612	3/8" B.S.F. Socket Set Screw, Taper Point 3/4" long
20	236/182226	Oil Retaining Bush 1.1/8" x 1.3/8" x 1.5/8" long
21	139/13	3/8" Headed Taper Pin 1.1/2" long
22	569X.113	Driven Gear
23	569X.109A	Pump Shaft
24	569Y.103A	Coolant Pump Rear Cover
25	569Z.101	Coolant Pump Body
26	---	1" Gas Plug
27	236/182226	Oil Retaining Bush 1.1/8" x 1.3/8" x 1.5/8" long
28	569X.104	Pump Gear
29	569X.108	Pump Drive Shaft
30	569X.107	Key

**Refer to drawing
showing all part
numbers**

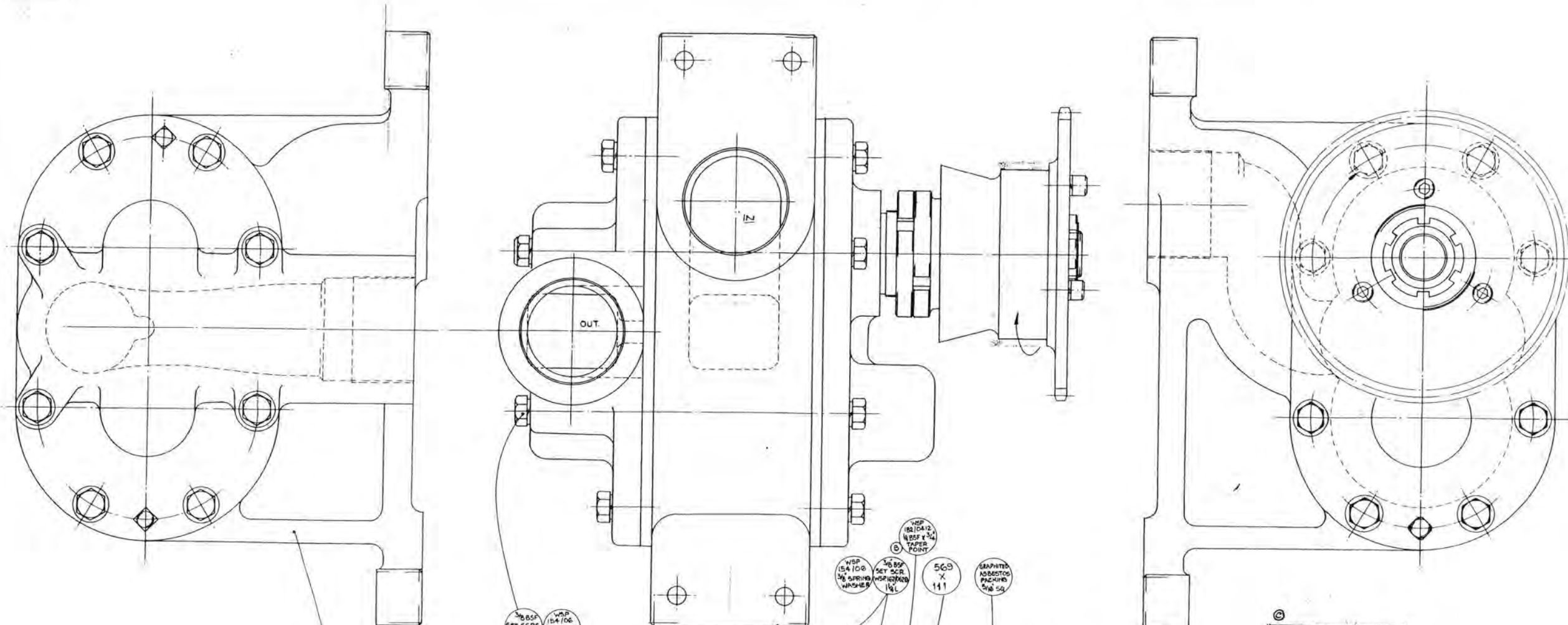

TAPER PINS WERE
7/8 DIA X 1/4 PARALLEL
DOWELS ON PROTOTYPE

(A) 6886 H.J.G. 19-1-51

(B) 6886 H.J.G. 20-12-51

(C) 800A.100
REV. 25-8-54

(D) 500A320.402
31-7-57

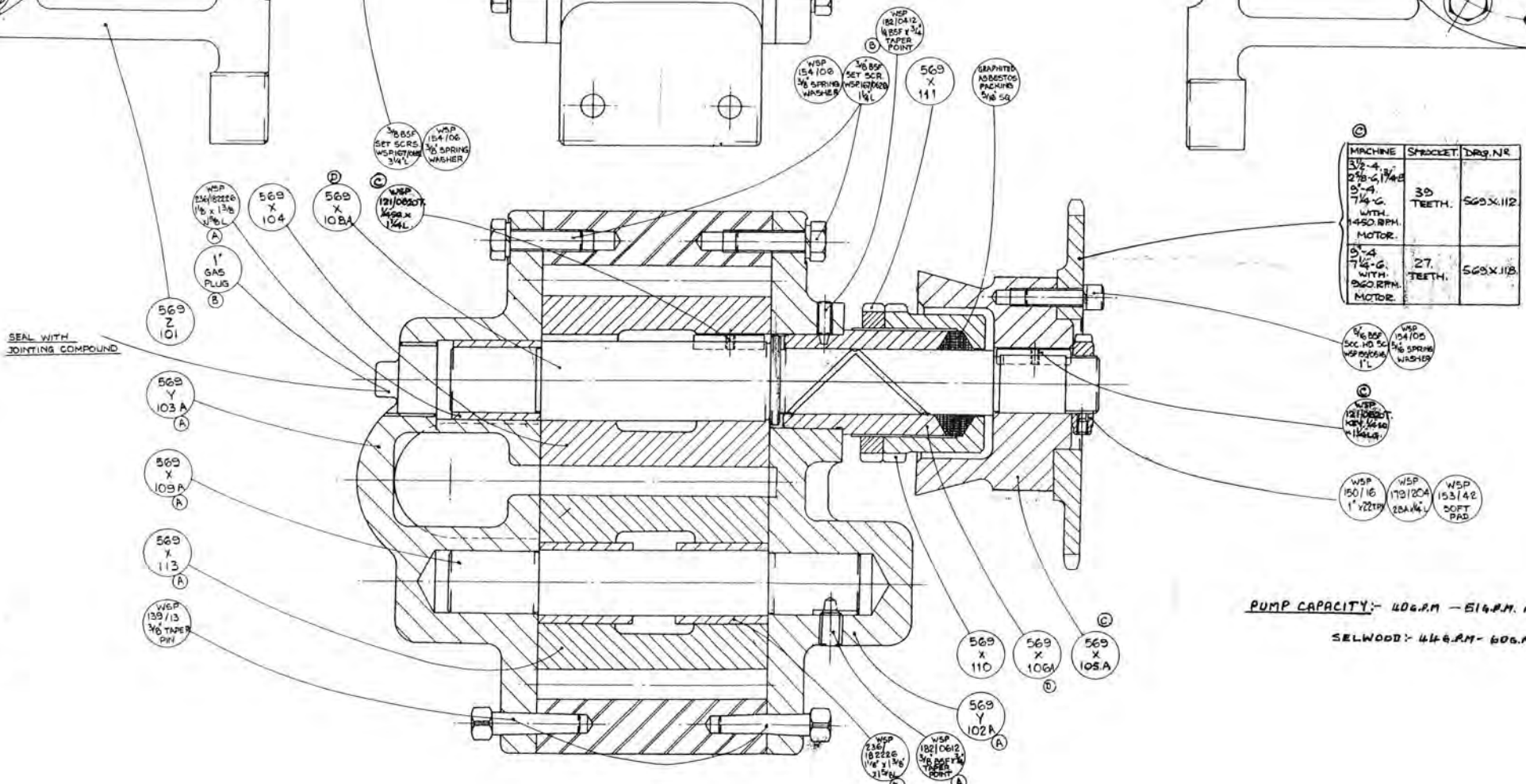

MACHINE	SPOCKET	DRG. NR.
5 1/2 - 4 2 7/8 - 6 1/4 1 5/8 - 4 7/8 - 2	3D TEETH.	569 X 112
5 1/2 - 4 7/8 - 2 WITH 1450 RPM MOTOR.	27 TEETH.	569 X 113

PUMP CAPACITY:- 40 G.P.M. - 51 1/2 G.P.M. AT 20 P.S.I.

SELWOOD:- 44 G.P.M. - 60 G.P.M. AT 20 P.S.I.

WILKINSON TOOL
MANUFACTURING CO. LTD.



MACHINE TOOL DESIGN
CONVENT - ENGLAND

COPYRIGHT

DESCRIPTION

COOLANT PUMP.

FULL SIZE	RM	26-248
	LOP	569L12A

569	7 1/4 - 6
569	9 - 4
	1 1/4 - 8
	2 1/2 - 6
	3 1/2 - 4

TRACED DATE
A.T.S. 7-5-52

WE HAVE ALL RIGHTS
RESERVED IN THIS
DRAWING AND THE
DESIGN THEREON
AND WILL BE
RESPONSIBLE FOR
THE PROTECTION
THEREOF

569Z.1

CROSS SLIDE OPERATION - DRAWING NO. 541 Z 3B

<u>INDEX</u> <u>NO.</u>	<u>PART</u> <u>NO.</u>	<u>TITLE</u>	
1	541Z.102	Rear Cross-Slide Cam Lever	Refer to drawing showing all part numbers
2	236/242824	Oil Retaining Bush 1.1/2" x 1.	
3	236/242836	Oil Retaining Bush 1.1/2" x 1.	
4	541X.133	Spacing Washer	
5	541X.131	Oil Retaining Bush 1.3/4" bore long	
6	541X.142	Plug for Drum Housing	
7	541X.141	Sliding Sleeve	
8	541X.119	Tee Bolt	
9	173/16L	1" Locknut	
10	541X.116	Slotted Washer	
11	541X.124X	Lower Approach Pin	
12	541X.125	Lower Approach Bush	
13	541X.112	Pivot Pin	
14	236/182214	Oil Retaining Bush 1.1/8" x 1.3/8" x 7/8" long	
15	212/18	1/8" B.S.P. Grease Nipple	
16	541Y.113	Lower Quadrant Pivot	
17	36/243036	Oil Retaining Bush 1.1/2" x 1.7/8" x 2.1/4" long	
18	30/16	1" Washer	
19	173/16L	1" B.S.F. Locknut	
20	541Y.138	End Bracket	
21	155/0624	3/8" B.S.F. Socket Head Cap Screw 1.1/2" long	
22	154/06	3/8" Spring Washer	
23	236/182218	Oil Retaining Bush 1.1/8" x 1.3/8" x 1.1/8" long	
24	541Y.136A	Upper Quadrant Shaft	
25	101/13	1.1/8" External Circlip	
26	541X.155	Pivot Pin	
27	236/182214	Oil Retaining Bush 1.1/8" x 1.3/8" x 7.8" long	
28	141/7	11/32" Extractable Taper Pin 1.3/4" long	
29	522Z.104	Beam	
30	522Z.101	Drum Housing	
31	541X.130	Oil Retaining Bush 1.1/8" bore x 1.3/8" o/d. x 5/8" long	
32	541X.126	Lower Connecting Link Pin	
33	236/182214	Oil Retaining Bush 1.1/8" x 1.3/8" x 7/8" long	
34	236/242824	Oil Retaining Bush 1.1/2" x 1.3/4" x 1.1/2" long	
35	236/42836	Oil Retaining Bush 1.1/2" x 1.3/4" x 2.1/4" long	
36	182/0624	3/8" B.S.F. Hexagon Socket Set Screw, Taper Point 1.1/2" long	
37	173/06	3/8" Hexagon Nut	
38	541X.139	Approach Arm Shaft	
39	541X.121	Cam Roller	
40	139/11	11/32" Square Head Taper Pin 2" long	
41	541X.123	Feed Roller Pin	
42	541X.122	Approach Roller Pin	
43	541X.148B	Scale for Cam Lever (Upper Rear)	
44	165/406	4 B.A. Round Head Set Screw 3/8" long	
45	541X.152B	Metric Scale for Cam Lever (Upper Rear)	
46	541X.116	Slotted Washer	
47	541X.142	Plug for Drum Housing	
48	173/16L	1" B.S.F. Locknut	
49	541X.119	Tee Bolt	
50	541X.117A	Sliding Sleeve	

CROSS SLIDE OPERATION - DRAWING NO. 541 Z 3B

<u>INDEX</u> <u>NO.</u>	<u>PART</u> <u>NO.</u>	<u>TITLE</u>
51	541X.131	Oil Retaining Bush 1.3/4" bore x 2" o/d x 1.3/32" long
52	155/0412	1/4" B.S.F. Socket Head Cap Screw 3/4" long
53	154/04	1/4" Spring Washer
54	541X.128	Approach Anchor Pin
55	541Y.103	Approach Anchor Link
56	236/242836	Oil Retaining Bush 1.1/2" x 1.3/4" x 2.1/4" long
57	541X.127	Cam Lever Pivot
58	173/06	3/4" B.S.F. Hexagon Nut
59	182/0620	3/8" B.S.F. Hexagon Socket Set Screw, Taper Point 1.1/4" long

CROSS SLIDE OPERATION - DRAWING NO. 541 Z 2B

<u>INDEX NO.</u>	<u>PART NO.</u>	<u>TITLE</u>	Refer to drawing showing all part numbers
1	236/242836	Oil Retaining Bush 1.1/2" bore 2.1/4" long	
2	182/0620	3/8" B.S.F. Hexagon Socket Set 1.1/4" long	
3	173/06	3/8" B.S.F. Hexagon Nut	
4	236/242836	Oil Retaining Bush 1.1/2" bore x 1.3/4" o/d x 2.1/4" long	
5	541X.133	Spring Washer	
6	154/04	1/4" Spring Washer	
7	155/0412	1/4" B.S.F. Socket Head Cap Screw	
8	541X.131	Oil Retaining Bush 1.3/4" bore x 2" o/d x 1.3/32" long	
9	541X.117A	Sliding Sleeve	
10	541X.119	Tee Bolt	
11	541X.142	ug for Drum Housing	
12	173/16L	1" B.S.F. Locknut	
13	541X.116	Slotted Washer	
14	165/406	4 B.A. Round Head Set Screw 3/8" long	
15	541X.147B	Scale for Cam Lever (Upper Front)	
16	541X.151B	Metric Scale for Upper Cross Slide only	
17	541X.124A	Lower Approach Pin	
18	541X.125	Lower Approach Bush	
19	541X.122	Approach Roller Pin	
20	541X.139	Approach Arm Shaft	
21	182/0624	3/8" B.S.F. Hexagon Socket Set Screw, Taper Point	
22	173/06	3/8" B.S.F. Hexagon Nut	
23	236/242824	Oil Retaining Bush 1.1/2" bore x 1.3/4" o/d x 1.1/2" long	
24	236/242836	Oil Retaining Bush 1.1/2" bore x 1.3/4" o/d x 2.1/4" long	
25	236/182214	Oil Retaining Bush 1.1/8" bore x 1.3/8" o/d x 7/8" long	
26	541X.126	Lower Connectinb Link Pin	
27	541X.130	Oil Retaining Bush 1.1/8" bore x 1.3/8" o/d x 5/8" long	
28	522Z.101	Drum Housing	
29	522Z.104	Beam	
30	141/7	13/32" Extractable Taper Dowel 1.3/4" long	
31	236/182214	Oil Retaining Bush 1.1/8" bore x 1.3/8" o/d x 7/8" long	
32	236/182218	Oil Retaining Bush 1.1/8" bore x 1.3/8" o/d x 1.1/8" long	
33	541X.155	ot Pin	
34	101/33	1.1/8" External Circlip	
35	541Y.136A	Upper Quadrant Shaft	
36	154/06	3/8" Spring Washer	
37	155/0624	3/8" B.S.F. Socket Head Cap Screw 1.1/2" long	
38	541Y.138	End Bracket	
39	541X.158A	Spring Anchor	
40	173/16L	1" B.S.F. Locknut	
41	130/16	1" Washer	
42	541X.121	Cam Roller	
43	541X.123	Feed Roller Pin	
44	36/243036	Oil Retaining Bush 1.1/2" bore x 1.7/8" o/d x 2.1/4" long	

CROSS SLIDE OPERATION - DRAWING NO. 541 Z 2B

<u>INDEX NO.</u>	<u>PART NO.</u>	<u>TITLE</u>
45	541X.113	Lower Quadrant Pivot
46	212/18	1/8" Gas Grease Nipple
47	236/182214	Oil Retaining Bush 1.1/8" bore x 1.3/8" o/d x 7/8" long
48	41X.112	Pivot Pin
49	139/11	11/32" Square Head
50	541X.116	Slotted Washer
51	173/16L	1" B.S.F. Locknut
52	541X.119	Tee Bolt
53	541X.141	Sliding Sleeve
54	541X.142	Plug for Drum Housing
55	541X.131	Oil Retaining Bush 1.3/4" bore x 2" o/d x 1.3/32" long
56	541X.128	Approach Anchor Pin
57	36/242824	Oil Retaining Bush 1.1/2" bore x 1.3/4" o/d x 1.1/2" long
58	541X.137	Cam Lever Pivot
59	541Y.103	Approach Link
60	541Z.101	Front Cross-Slide Cam Lever

872
 LIST ISSUE 24 MARCH
 DISPATCHED BY
 SUBMITTED BY
 ALTERATIONS
 A 6354 C.BELL 12.10.50
 B A.L.T. 6821 D.C.F. 23.8.51
 C 500A106 R.S. 25.8.51
 D 500A106 R.S. 11.2.52
 E 500A.107 R.S. 24.3.52
 F 500A.108 R.S. 20.10.52
 G 500A.109 R.S. 20.10.52
 H 500A.110 R.S. 20.10.52

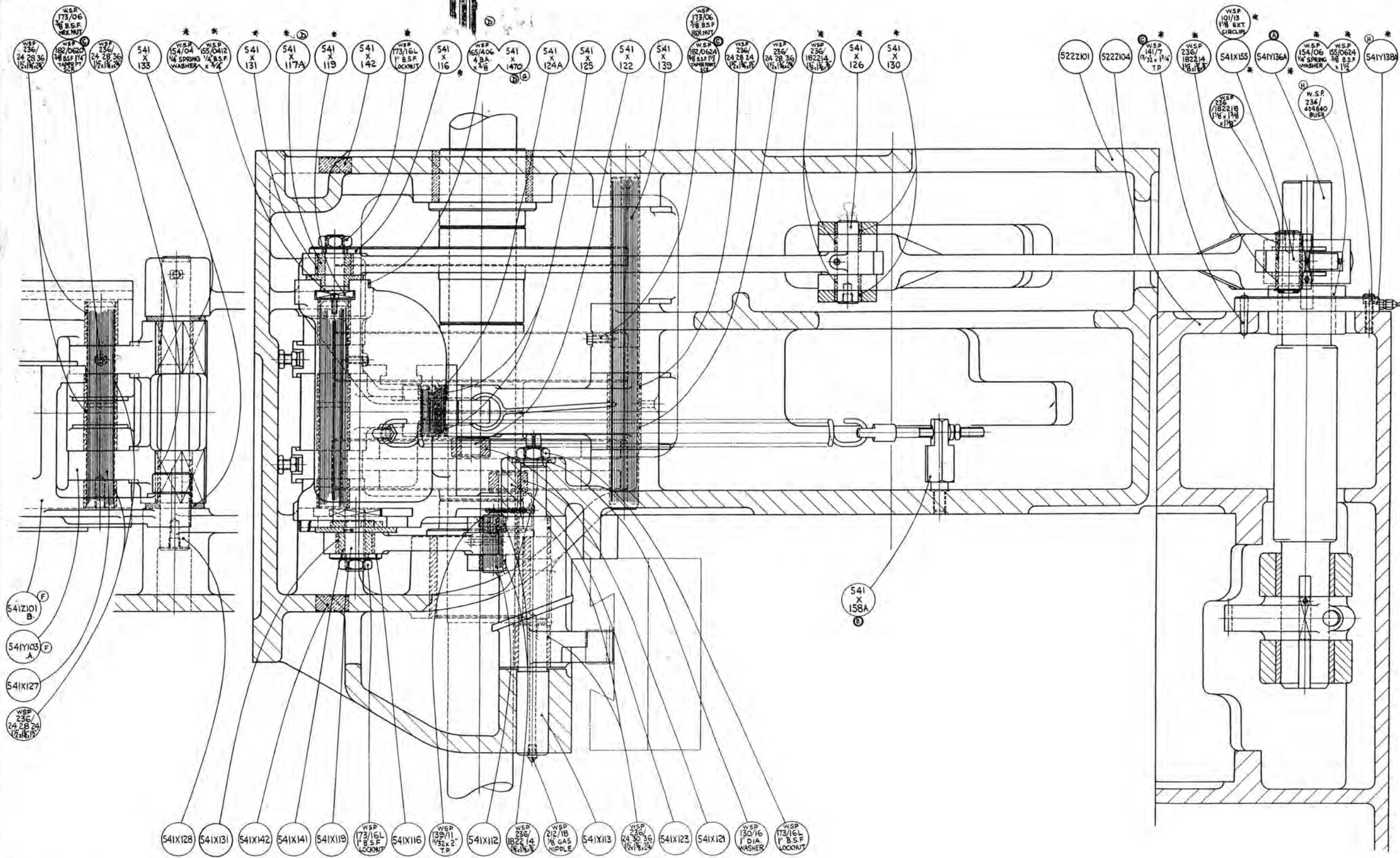

WICKMAN MACHINE TOOL MANUFACTURING CO. LTD.

DATE	DRAWN	M.G.J.	23.9.48	REVISED	LOP
	CHECKED	B.S.	25.7.49		541L122344

541	714-G
	5-4
	278-G
	134-B

CHECKED BY 7.2.52
 MID CO 23.10.52
 * DENOTES SECTION 541A. (FRONT UPPER CROSS SLIDE)
 54122-B

CROSS SLIDE OPERATION - DRAWING NO. 541 Z 1B

<u>INDEX</u> <u>NO.</u>	<u>PART</u> <u>NO.</u>	<u>TITLE</u>	Refer to drawing showing all part numbers
1	541Z.101A	Front Cross-Slide Cam Lever	
2	154/04	1/4" Spring Washer	
3	155/0412	1/4" B.S.F. Socket Head Cap Scr	
4	541X.118	Indicating Pin	
5	125/2244	11/32" Taper Pin 2.3/4" long	
6	541Y.106	Front Quadrant Link	
7	173/06	3/8" B.S.F. Hexagon Nut	
8	182/0620	3/8" Hexagon Socket Set Screw, Taper Point 1.1/4" long	
9	541Z.114	Front Quadrant	
10	154/07	7/16" Spring Washer	
11	155/0720	7/16" B.S.F. Socket Head Cap Screw 1.1/4" long	
12	125/3224	1/2" Taper Pin, 2.3/4" long	
13	541Y.143	Gear Segment for Quadrant	
14	541Y.104	Forked Approach Arm	
15	541Y.108	Lower Connecting Link	
16	125/2240	11/32" Taper Pin, 2.1/2" long	
17	541Y.109	Forked Intermediate Lever	
18	330/40	Purefoy Spherical Washer	
19	173/08L	1/2" B.S.F. Locknut	
20	173/08	1/2" B.S.F. Plain Nut	
21	541Y.110	Forked Upper Link	
22	236/242836	Oil Retaining Bush 1.1/2" x 1.3/4" x 2.1/4" long	
23	182/0624	3/8" B.S.F. Hexagon Socket Set Screw, Taper Point 1.1/2" long	
24	173/06	3/8" B.S.F. Hexagon Nut	
25	541X.140	Intermediate Lever Pivot	
26	236/242824	Oil Retaining Bush 1.1/2" x 1.3/4" x 1.1/2" long	
27	541X.130	Oil Retaining Bush 1.1/8" x 1.3/8" x 5/8" long	
28	541X.126	Lower Connecting Link Pin	
29	541X.129	Oil Retaining Bush 1.1/8" x 1.3/8" x 27/32" long	
30	236/182218	Oil Retaining Bush 1.1/8" x 1.3/8" x 1.1/8" long	
31	541Y.111A	Keyed Upper Lever	
32	143/0620B	3/16" Mills Grooved Pin, Type G.P.2. 1.1/4" long	
33	155/1044	5/8" B.S.F. Socket Head Cap Screw, 2.3/4" long	
34	154/10	5/8" Spring Washer	
35	541X.137	Square Key	
36	541Y.135A	Upper Quadrant	
37	155/1044	5/8" B.S.F. Socket Head Cap Screw 2.3/4" long	
38	154/10	5/8" Spring Washer	
39	541Y.135A	Upper Quadrant	
40	41X.137	Square Key	
41	143/0620B	3/16" Mills Grooved Pin Type G.P.2, 1.1/4" long	
42	155/1044	5/8" B.S.F. Socket Head Cap Screw 2.3/4" long	
43	154/10	5/8" Spring Washer	
44	541Y.111A	Keyed Upper Lever	
45	522Z.104	Beam	
46	236/182218	Oil Retaining Bush 1.1/8" x 1.1/2" x 1.1/8" long	
47	572ZX.111	Instruction Plate, Upper Cross-Slide Lever	
48	165/204	2 B.A. Round Head Set Screw 1/4" long	
49	541X.161	Special Locknut	
50	541X.160	Special Locknut	
51	541Y.110	Forked Upper Link	
52	541Y.109	Forked Intermediate Lever	

CROSS SLIDE OPERATION - DRAWING NO. 541 Z 1B

<u>INDEX</u> <u>NO.</u>	<u>PART</u> <u>NO.</u>	<u>TITLE</u>
53	541X.157A	Spring Adjuster.
54	541Y.159	Tension Spring
55	125/2240	11/32" Taper Pin 2.1/2" long
56	541Y.108	Lower Connecting Link
57	541Y.104	Forked Approach Arm
58	541Y.143	Gear Segment for Quadrants
59	125/3224	1/2" Taper Pin 1.1/2" long
60	155/0720	7/16" B.S.F. Socket Head Cap Screw 1.1/4" long
61	154/07	7/16" Spring Washer
62	541Z.115	Rear Quadrant
63	182/0620	3/8" Hexagon Socket Set Screw, Taper Point, 1.1/4" long
64	173/06	3/8" B.S.F. Hexagon Nut
65	541Y.107	Rear Quadrant Link
66	125/2244	11//32" Taper Pin 2.3/4" long
67	541X.118	Indicating Pin
68	155/0412	1/4" B.S.F. Socket Head Cap Screw 3/4" long
69	154/04	1/4" Spring Washer
70	541Z.102A	Rear Cross-Slide Cam Lever
71	541X.156	Spring Anchor
72	165/406	4 B.A. Round Head Set Screw, 3/8" long
73	541X.146	Scale for Cam Lever (Lower Rear)
74	541X.150A	Metric Scale for Lower Rear Cross Slide
75	154/04	1/4" Spring Washer
76	155/0412	1/4" B.S.F. Socket Head Cap screw, 3/4" long
77	541X.120	Stop Pad
78	188/0824	1/2" B.S.F. Square Head Set Screw, 1.1/2" long
79	173/08L	1/2" B.S.F. Locknut
80	541X.144	Bush for Stop Screw
81	541Y.103	Approach Anchor Link
82	182/0624	3/8" B.S.F. Hexagon Socket Set Screw, Taper Point 1.1/2" long
83	173/06	3/8" B.S.F. Hexagon Nut
84	41Y.105	Lower Approach Link
85	125/2232	11/32" Taper Pin 2" long
86	522Z.101	Drum Housing
87	125/2232	11/32" Taper Pin 2" long
88	541Y.105	Lower Approach Link
89	182/0624	3/8" B.S.F. Hexagon Socket Set Screw, Taper Point 1.1/2" long
90	173/06	3/8" B.S.F. Hexagon Nut
91	541Y.103	Approach Anchor Link
92	541X.144	Bush for Stop Screw
93	173/08L	1/2" B.S.F. Locknut
94	188/0824	1/2" B.S.F. Square Head Set Screw, Taper Point 1.1/2" long
95	541X.120	Stop Pad
96	154/04	1/4" Spring Washer
97	155/0412	1/4" B.S.F. Socket Head Cap Screw, 3/4" long
98	165/406	4 B.A. Round Head Set Screw, 3/8" long
99	541X.145A	Scale for Cam Lever (Lower Front)
100	541X.149A	Metric Scale for Lower Front Cross Slide
101	--	1/4" o/d, Tube 1.3/8" long

DRUM LOCKING - DRAWING NO. 561 Z 1A

**Refer to drawing
showing all part
numbers**

<u>INDEX</u> <u>NO.</u>	<u>PART</u> <u>NO.</u>	<u>TITLE</u>
1	561X.111A	Bush for Drum Latch Pin
2	561X.137A	Plug for Drum Housing
3	561X.109	Latch Pin
4	182/0624	3/8" B.S.F. Socket Set Screw, 1.1/2" long
5	561X.140	Pillar
6	182/0616	3/8" B.S.F. Socket Set Screw, 1" long
7	173/06L	3/8" B.S.F. Hexagon Locknut
8	182/0624	3/8" B.S.F. Socket Set Screw, Taper Point 1.1/2" long
9	1X.110	Bush for Drum Latch Pin
10	173/06L	3/8" B.S.F. Hexagon Locknut
11	182/0620	3/8" B.S.F. Socket Set Screw, Taper Point 1.1/4" long
12	561X.108A	Drum Latch
13	561X.141	Retaining Rod for Drum Latch
14	561X.113	Spring for Drum Latch
15	561X.114X	Spring Retaining Plug
16	173/08L	1/2" B.S.F. Hexagon Locknut
17	561X.142	Pin
18	127/0406	1/16" Split Pin 3/4" long
19	561X.150	Collar
20	561X.149	Stop Screw
21	154/06	3/8" Spring Washer
22	155/0616	3/8" B.S.F. Socket Head Cap Screw, 1" long
23	561X.131	Drum Locking Pad
24	561Y.104	Toggle Lever
25	236/242824	Oil Retaining Bush 1.1/2" x 1.3/4" x 1.1/2"
26	561X.124	Pin for Toggle Lever
27	561X.105	Toggle Lever
28	561X.123	Pin
29	101/13	1.1/8" External Circlip
30	182/0620	3/8" B.S.F. Socket Set Screw, Taper Point 1.1/4" long
31	173/06L	3/8" B.S.F. Hexagon Locknut
32	561Y.103A	Lever
33	561X.146	Operating Link
34	561Y.102A	Toggle Lever
35	561Y.127A	Drum Locking Shaft
36	173/12	3/4" B.S.F. Hexagon Nut
37	561X.129	Locking Washer
38	561X.130B	Locking Sleeve
39	182/0824	1/2" B.S.F. Socket Set Screw, Taper Point 1.1/2" long
40	173/08L	1/2" B.S.F. Hexagon Locknut
41	182/0624	3/8" B.S.F. Socket Set Screw Taper Point 1.1/2" long
42	173/06L	3/8" B.S.F. Hexagon Locknut
43	561X.125	Pin for Glut
44	101/6	3/4" External Circlip
45	561X.128B	Pin for Toggle Lever
46	176/0812	1/2" B.S.F. Socket Set Screw, Cup Point 3/4" long

FIRST USED ON BATCH
LAST USED ON BATCH
SUPERSEDED
SUPERSEDED BY

ALTERATIONS

(A)	631D NUB 15.9.04
(B)	6334 NUB 26.6.5
(C)	6045 J.L. 26.6.5
(D)	ALT 6066 12.10.1
(E)	ALT 500 P. 145. RES. 10-3-53
(F)	ALT 500 A. 202. RES. 6-7-55
(G)	500A320 11-4-57
(H)	500A100 11-4-57
(I)	500A140 11-4-57

NOTE:
WHEN ADJUSTING DRUM LOCKING
TOGGLE MECHANISM SET FIT FOR
TOGGLE LEVER 561X125A WITH
HIGH POINT OF ECCENTRICITY
ALONG ARC SHOWN.

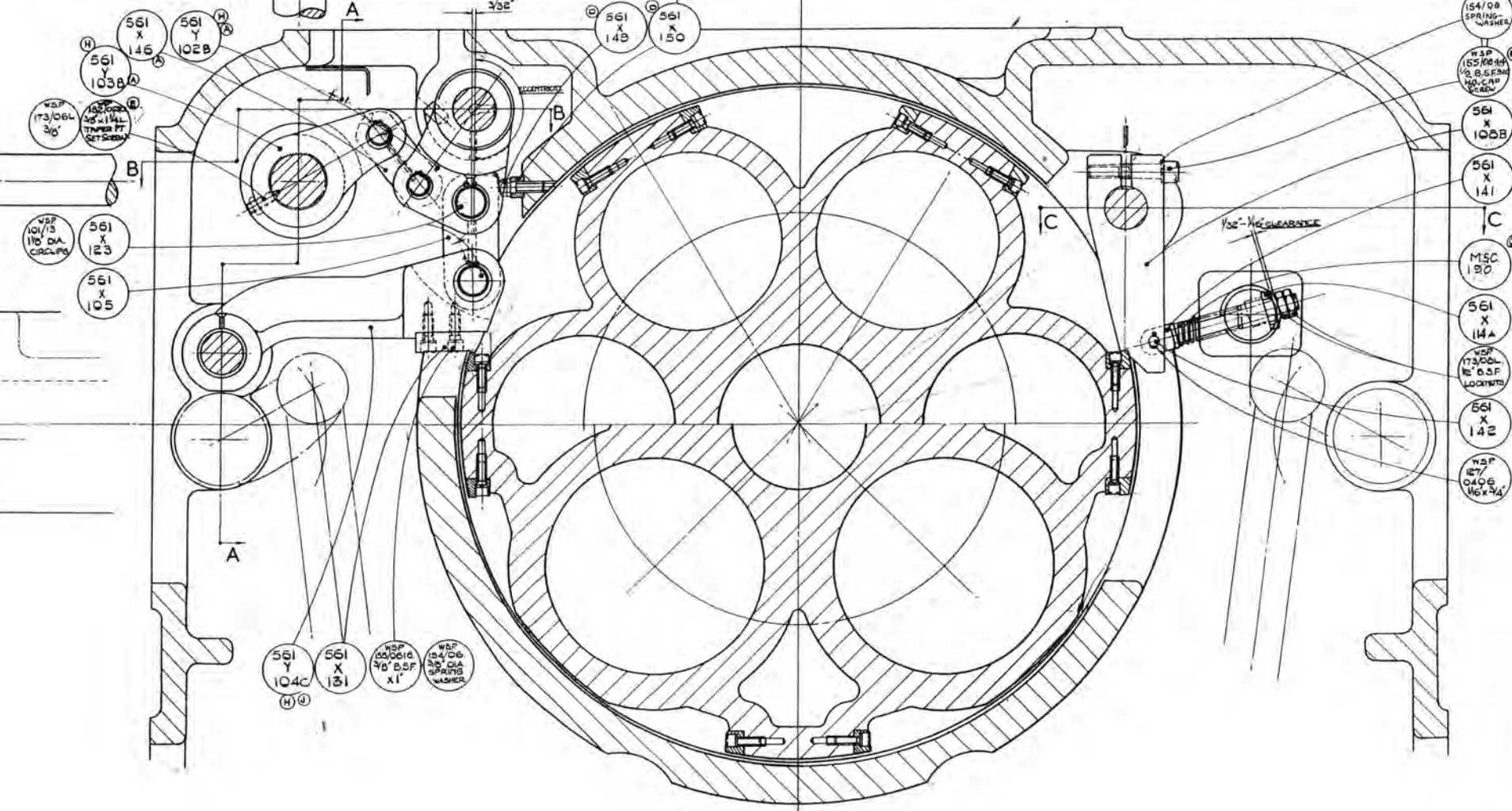
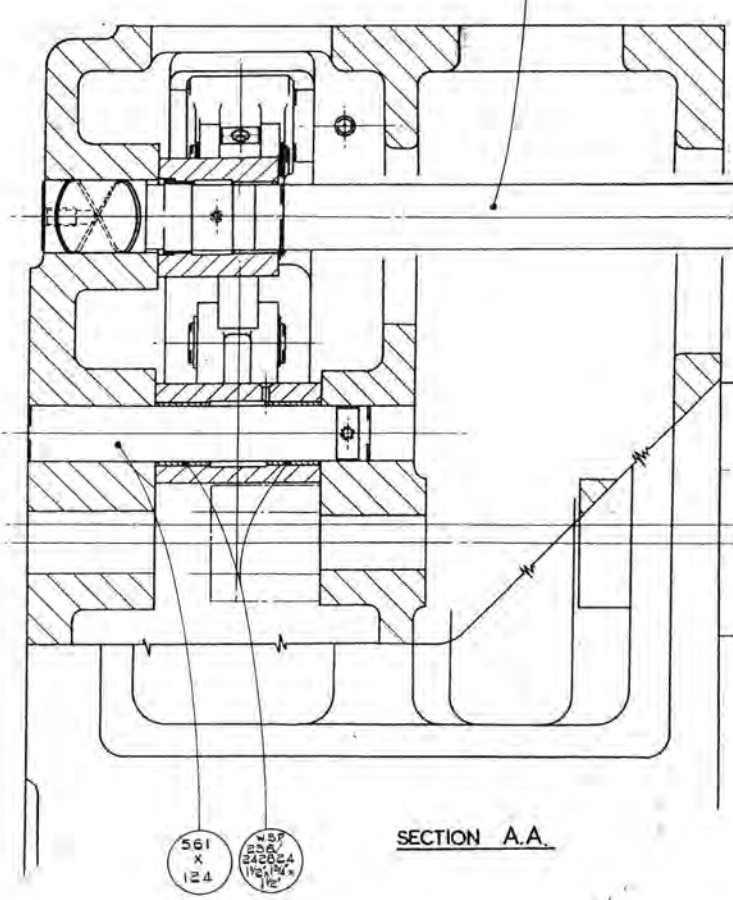
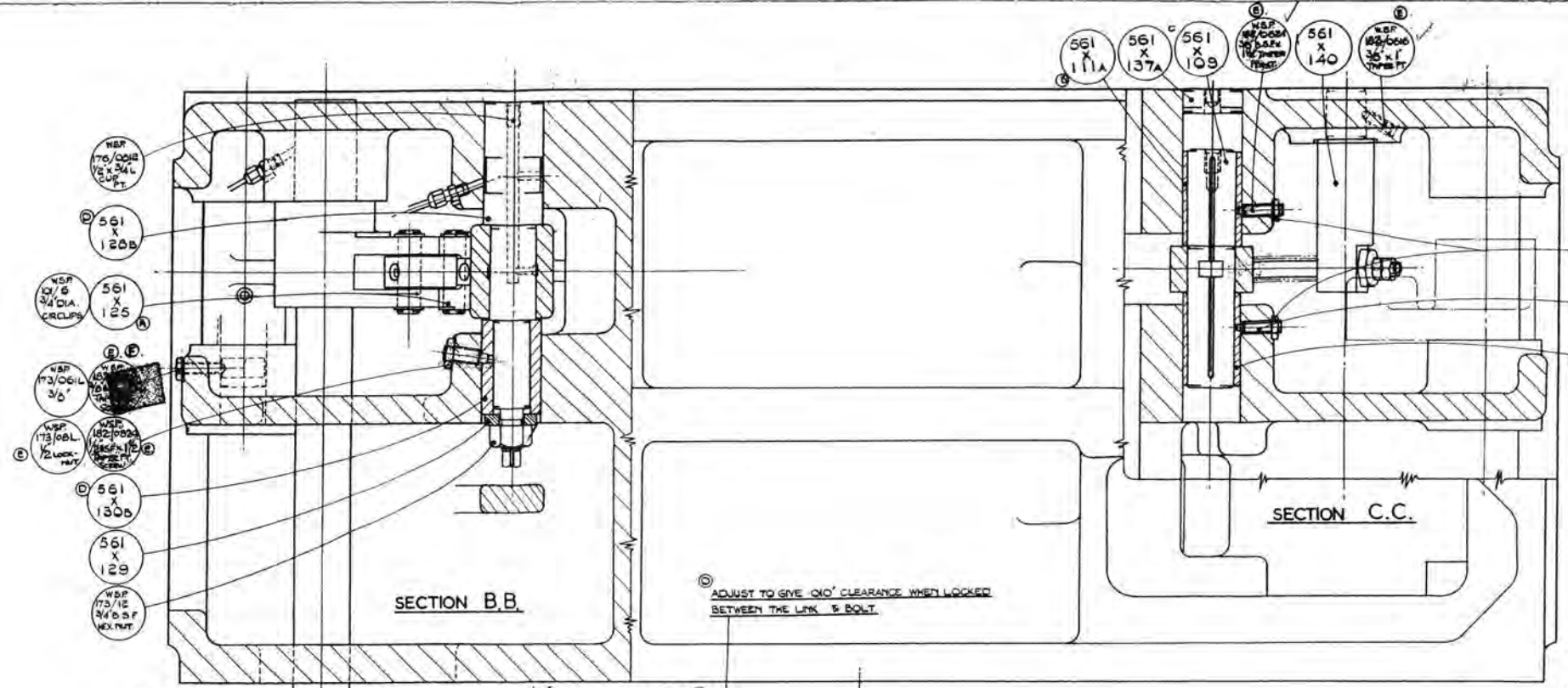

- (C) WSP 154/08 SPRING-WASHER
- (E) WSP 155/08 SPRING-WASHER
- (C) 561 X 100B
- (C) 561 X 141
- (C) MSC 120
- (C) 561 X 14A
- (E) WSP 173/08L 1/2 B.S.F. LOCKWASHER
- (C) 561 X 142
- (E) WSP 127/0406 1/2 X 3/4

UTR 1/2 MAG 58

REMOVE ALL MARKS FROM DRAWING UNLESS OTHERWISE SPECIFIED

TOLERANCE ON DIMENSIONS UNLESS OTHERWISE SPECIFIED

AMERICAN PRACTICE

WHEN NECESSARY DIMENSIONS SHALL BE IN INCHES UNLESS OTHERWISE SPECIFIED

561	7/16
561	5/8
561	3/4
561	1
561	1 1/8
561	1 1/4
561	1 3/8
561	1 1/2
561	1 3/4
561	2
561	2 1/4
561	2 1/2
561	2 3/4
561	3
561	3 1/4
561	3 1/2
561	3 3/4
561	4
561	4 1/4
561	4 1/2
561	4 3/4
561	5
561	5 1/4
561	5 1/2
561	5 3/4
561	6
561	6 1/4
561	6 1/2
561	6 3/4
561	7
561	7 1/4
561	7 1/2
561	7 3/4
561	8
561	8 1/4
561	8 1/2
561	8 3/4
561	9
561	9 1/4
561	9 1/2
561	9 3/4
561	10
561	10 1/4
561	10 1/2
561	10 3/4
561	11
561	11 1/4
561	11 1/2
561	11 3/4
561	12
561	12 1/4
561	12 1/2
561	12 3/4
561	13
561	13 1/4
561	13 1/2
561	13 3/4
561	14
561	14 1/4
561	14 1/2
561	14 3/4
561	15
561	15 1/4
561	15 1/2
561	15 3/4
561	16
561	16 1/4
561	16 1/2
561	16 3/4
561	17
561	17 1/4
561	17 1/2
561	17 3/4
561	18
561	18 1/4
561	18 1/2
561	18 3/4
561	19
561	19 1/4
561	19 1/2
561	19 3/4
561	20
561	20 1/4
561	20 1/2
561	20 3/4
561	21
561	21 1/4
561	21 1/2
561	21 3/4
561	22
561	22 1/4
561	22 1/2
561	22 3/4
561	23
561	23 1/4
561	23 1/2
561	23 3/4
561	24
561	24 1/4
561	24 1/2
561	24 3/4
561	25
561	25 1/4
561	25 1/2
561	25 3/4
561	26
561	26 1/4
561	26 1/2
561	26 3/4
561	27
561	27 1/4
561	27 1/2
561	27 3/4
561	28
561	28 1/4
561	28 1/2
561	28 3/4
561	29
561	29 1/4
561	29 1/2
561	29 3/4
561	30
561	30 1/4
561	30 1/2
561	30 3/4
561	31
561	31 1/4
561	31 1/2
561	31 3/4
561	32
561	32 1/4
561	32 1/2
561	32 3/4
561	33
561	33 1/4
561	33 1/2
561	33 3/4
561	34
561	34 1/4
561	34 1/2
561	34 3/4
561	35
561	35 1/4
561	35 1/2
561	35 3/4
561	36
561	36 1/4
561	36 1/2
561	36 3/4
561	37
561	37 1/4
561	37 1/2
561	37 3/4
561	38
561	38 1/4
561	38 1/2
561	38 3/4
561	39
561	39 1/4
561	39 1/2
561	39 3/4
561	40
561	40 1/4
561	40 1/2
561	40 3/4
561	41
561	41 1/4
561	41 1/2
561	41 3/4
561	42
561	42 1/4
561	42 1/2
561	42 3/4
561	43
561	43 1/4
561	43 1/2
561	43 3/4
561	44
561	44 1/4
561	44 1/2
561	44 3/4
561	45
561	45 1/4
561	45 1/2
561	45 3/4
561	46
561	46 1/4
561	46 1/2
561	46 3/4
561	47
561	47 1/4
561	47 1/2
561	47 3/4
561	48
561	48 1/4
561	48 1/2
561	48 3/4
561	49
561	49 1/4
561	49 1/2
561	49 3/4
561	50
561	50 1/4
561	50 1/2
561	50 3/4
561	51
561	51 1/4
561	51 1/2
561	51 3/4
561	52
561	52 1/4
561	52 1/2
561	52 3/4
561	53
561	53 1/4
561	53 1/2
561	53 3/4
561	54
561	54 1/4
561	54 1/2
561	54 3/4
561	55
561	55 1/4
561	55 1/2
561	55 3/4
561	56
561	56 1/4
561	56 1/2
561	56 3/4
561	57
561	57 1/4
561	57 1/2
561	57 3/4
561	58
561	58 1/4
561	58 1/2
561	58 3/4
561	59
561	59 1/4
561	59 1/2
561	59 3/4
561	60
561	60 1/4
561	60 1/2
561	60 3/4
561	61
561	61 1/4
561	61 1/2
561	61 3/4
561	62
561	62 1/4
561	62 1/2
561	62 3/4
561	63
561	63 1/4
561	63 1/2
561	63 3/4
561	64
561	64 1/4
561	64 1/2
561	64 3/4
561	65
561	65 1/4
561	65 1/2
561	65 3/4
561	66
561	66 1/4
561	66 1/2
561	66 3/4
561	67
561	67 1/4
561	67 1/2
561	67 3/4
561	68
561	68 1/4
561	68 1/2
561	68 3/4
561	69
561	69 1/4
561	69 1/2
561	69 3/4
561	70
561	70 1/4
561	70 1/2
561	70 3/4
561	71
561	71 1/4
561	71 1/2
561	71 3/4
561	72
561	72 1/4
561	72 1/2
561	72 3/4
561	73
561	73 1/4
561	73 1/2
561	73 3/4
561	74
561	74 1/4
561	74 1/2
561	74 3/4
561	75
561	75 1/4
561	75 1/2
561	75 3/4
561	76
561	76 1/4
561	76 1/2
561	76 3/4
561	77
561	77 1/4
561	77 1/2
561	77 3/4
561	78
561	78 1/4
561	78 1/2
561	78 3/4
561	79
561	79 1/4
561	79 1/2
561	79 3/4
561	80
561	80 1/4
561	80 1/2
561	80 3/4
561	81
561	81 1/4
561	81 1/2
561	81 3/4
561	82
561	82 1/4
561	82 1/2
561	82 3/4
561	83
561	83 1/4
561	83 1/2
561	83 3/4
561	84
561	84 1/4
561	84 1/2
561	84 3/4
561	85
561	85 1/4
561	85 1/2
561	85 3/4
561	86
561	86 1/4
561	86 1/2
561	86 3/4
561	87
561	87 1/4
561	87 1/2
561	87 3/4
561	88
561	88 1/4
561	88 1/2
561	88 3/4
561	89
561	89 1/4
561	89 1/2
561	89 3/4
561	90
561	90 1/4
561	90 1/2
561	90 3/4
561	91
561	91 1/4
561	91 1/2
561	91 3/4
561	92
561	92 1/4
561	92 1/2
561	92 3/4
561	93
561	93 1/4
561	93 1/2
561	93 3/4
561	94
561	94 1/4
561	94 1/2
561	94 3/4
561	95
561	95 1/4
561	95 1/2
561	95 3/4
561	96
561	96 1/4
561	96 1/2
561	96 3/4
561	97
561	97 1/4
561	97 1/2
561	97 3/4
561	98
561	98 1/4
561	98 1/2
561	98 3/4
561	99
561	99 1/4
561	99 1/2
561	99 3/4
561	100
561	100 1/4
561	100 1/2
561	100 3/4

WILKINSON ENGINE TOOL WORKS LTD. LEEDS

WILKINSON MACHINE TOOL DIVISION
COVENTRY - ENGLAND

COPYRIGHT

DRUM LOCKING ASSEMBLY.

4, 6, & 8 SPINDLE MACHINES.

NO.	DATE	BY	CHKD.	APP'D.	REVISION
561	7/4/56
561	8/1/56
561	8/1/56
561	8/1/56

DRUM LOCKING - DRAWING NO. 561 Z 2A

<u>INDEX</u> <u>NO.</u>	<u>PART</u> <u>NO.</u>	<u>TITLE</u>
1	561X.135A	Pin for Cam Lever
2	212/9004	1/4" B.S.F. x 90 deg. Grease Nipple
3	210/1725	1/4" Plastic Indicator Washer, Yellow
4	125/1628	1/4" Taper Pin, 1.3/4" long
5	561X.133	Roller Pin
6	561X.132	Cam Roller
7	212/18	1/8" B.S.P. Grease Nipple
8	210/2525	1/8" B.S.P. Plastic Indicator Washer. Yellow
9	101/18	1.1/2" External Circlip
10	561X.144	Washer for Drum Locking Lever
11	236/242828	Oil Retaining Bush 1.1/2" x 1.3/4" x 1.3/4"
12	561X.134	Adjusting Washer
13	101/6	3/4" External Circlip
14	561X.121A	Pin for Drum Locking Rod Link
15	210/2525	1/8" B.S.P. Plastic Indicator Washer, Yellow
16	212/18	1/8" B.S.P. Straight Grease Nipple
17	561Y.127A	Drum Locking Shaft
18	182/0620	3/8" B.S.F. Socket Set Screw, Taper Point 1.1/4" long
19	173/06L	3/8" B.S.F. Hexagon Locknut
20	236/242832	Oil Retaining Bush 1.1/2" x 1.3/4" x 2" long
21	561X.106A	Lever /
22	550X.136	Screw Locking Nut
23	550X.120A	Link Pin
24	101/15	1.1/4" External Circlip
25	561X.119A	Drum Locking Rod (Upper)
26	173/10L	5/8" B.S.F. Hexagon Locknut
27	561X.116A	Spring Tube
28	561X.122A	Spring Retaining Nut
29	125/1632	1/4" Taper Pin 2" long
30	561X.117A	Drum Locking Spring
31	561X.118A	End Cap for Spring Tube
32	561X.120A	Drum Locking Rod (Lower)
33	173/10L	5/8" B.S.F. Hexagon Locknut
34	561X.147	Link for Drum Locking Rod
35	173/06L	3/8" B.S.F. Hexagon Locknut
36	182/0624	3/8" B.S.F. Socket Set Screw, Taper Point 1.1/2" long
37	561Y.101A	Drum Locking Lever

**Refer to drawing
showing all part
numbers**

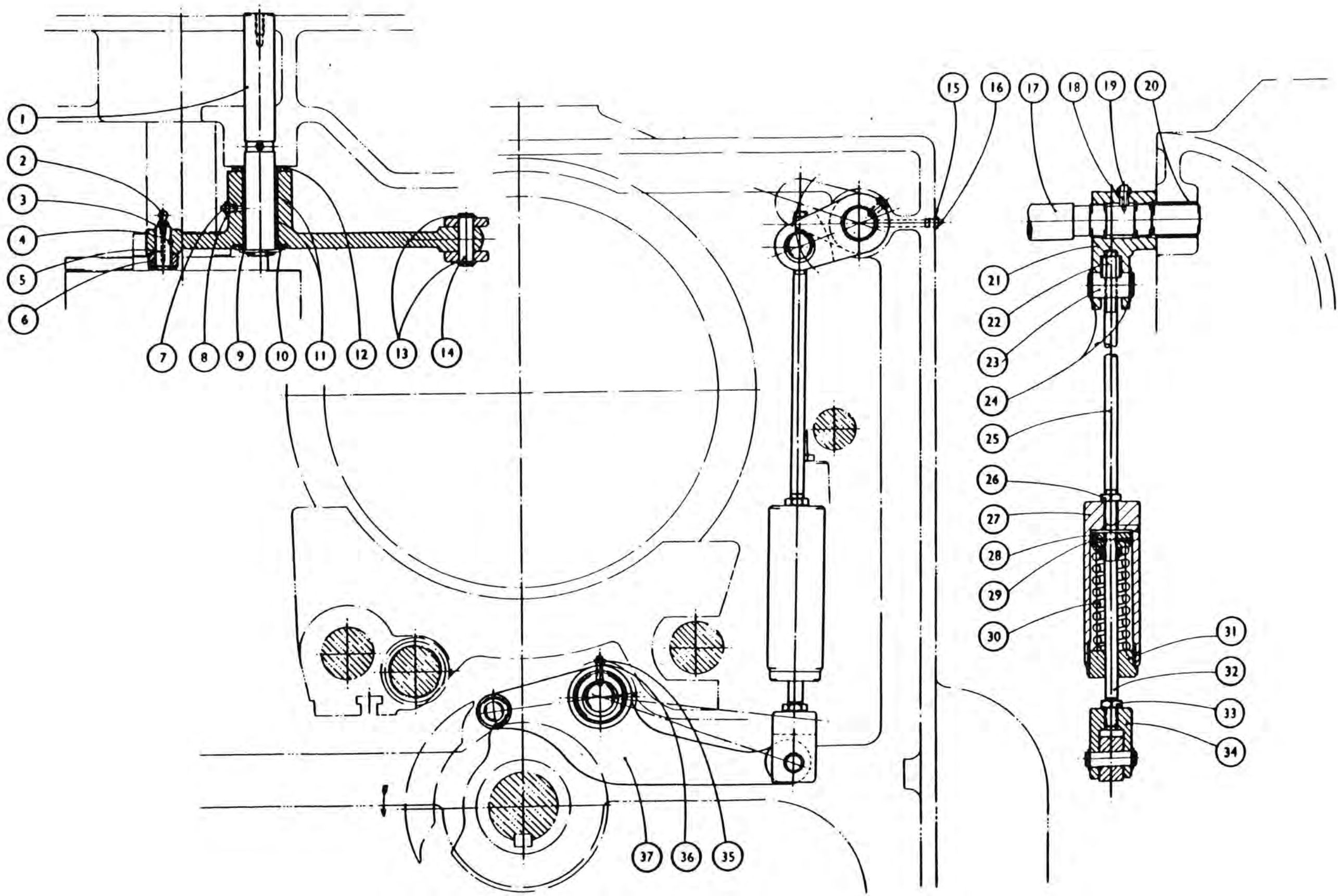

561Z2A

FEED BRAKE INTERLOCK - DRAWING NO. 553Y5

<u>INDEX</u> <u>NO.</u>	<u>PART</u> <u>NO.</u>	<u>TITLE</u>
1	522X.195A	Cover Plate
2	AW12-B1	Square D Limit Switch, Class 9007.
3	156/228	2 B.A. Socket Head Cap Screw 1.3/4" long
4	154/03	3/16" dia. Spring Washer
5	553X.112	Bracket
6	167/0524	5/16" B.S.F. Hexagon Head Set Screw 1.1/2" long
7	203/05	5/16" B.S.F. Self Locknut
8	155/0514	5/16" B.S.F. Socket Head Cap Screw 7/8" long
9	154/05	5/16" dia. Spring Washer
10	167/0412	1/4" B.S.F. Hexagon Head Set Screw 3/4" long
11	198/8	1/4" dia. Lockwasher

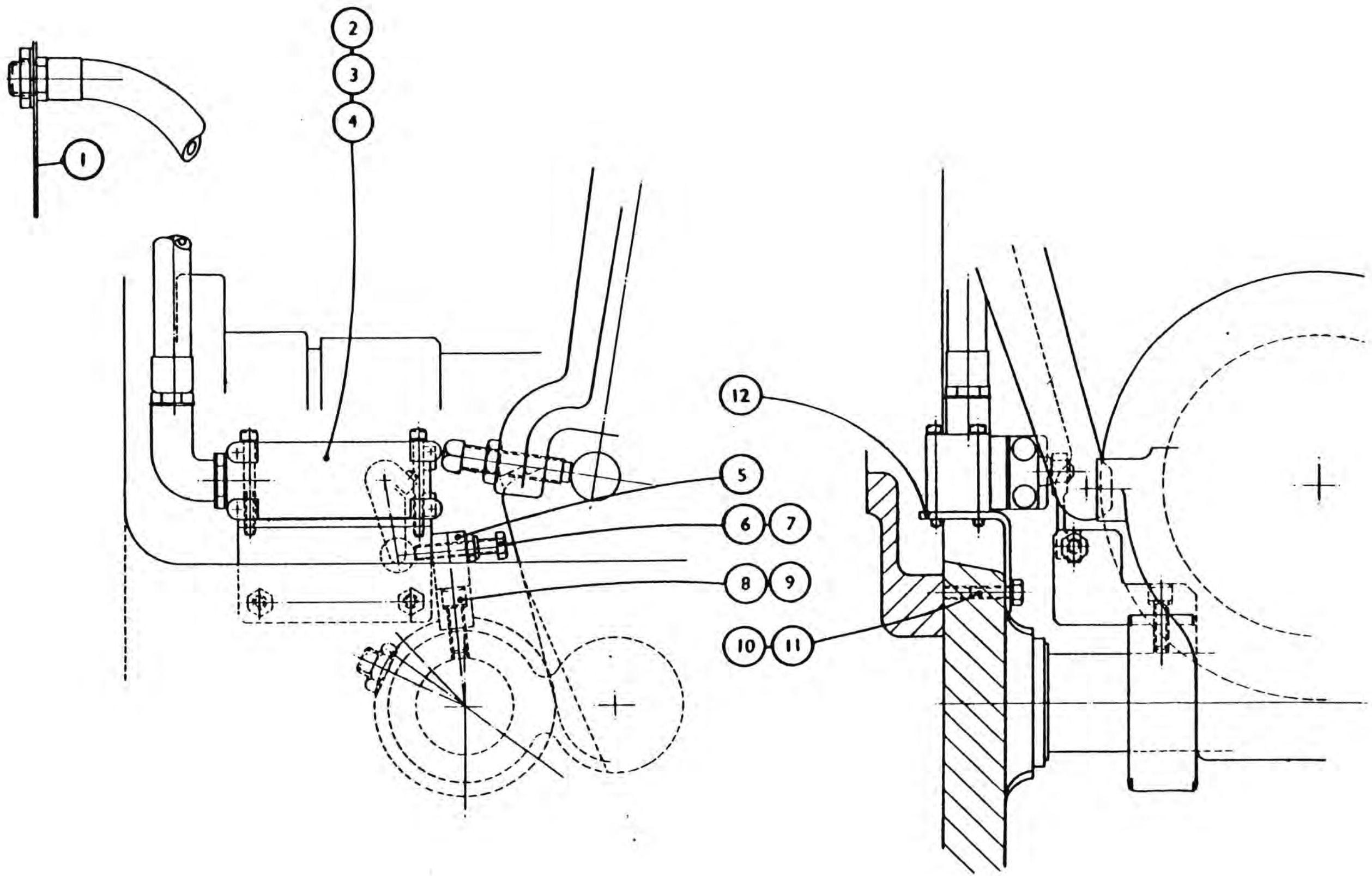

FIRST USED ON
LAST USED ON
SUPERSEDES 553 Y 5
SUPERSEDED BY
ALTERATIONS
ISSUE NOTE 500 A 518
CANCELLED 500A 653 J.G. Nov. 79

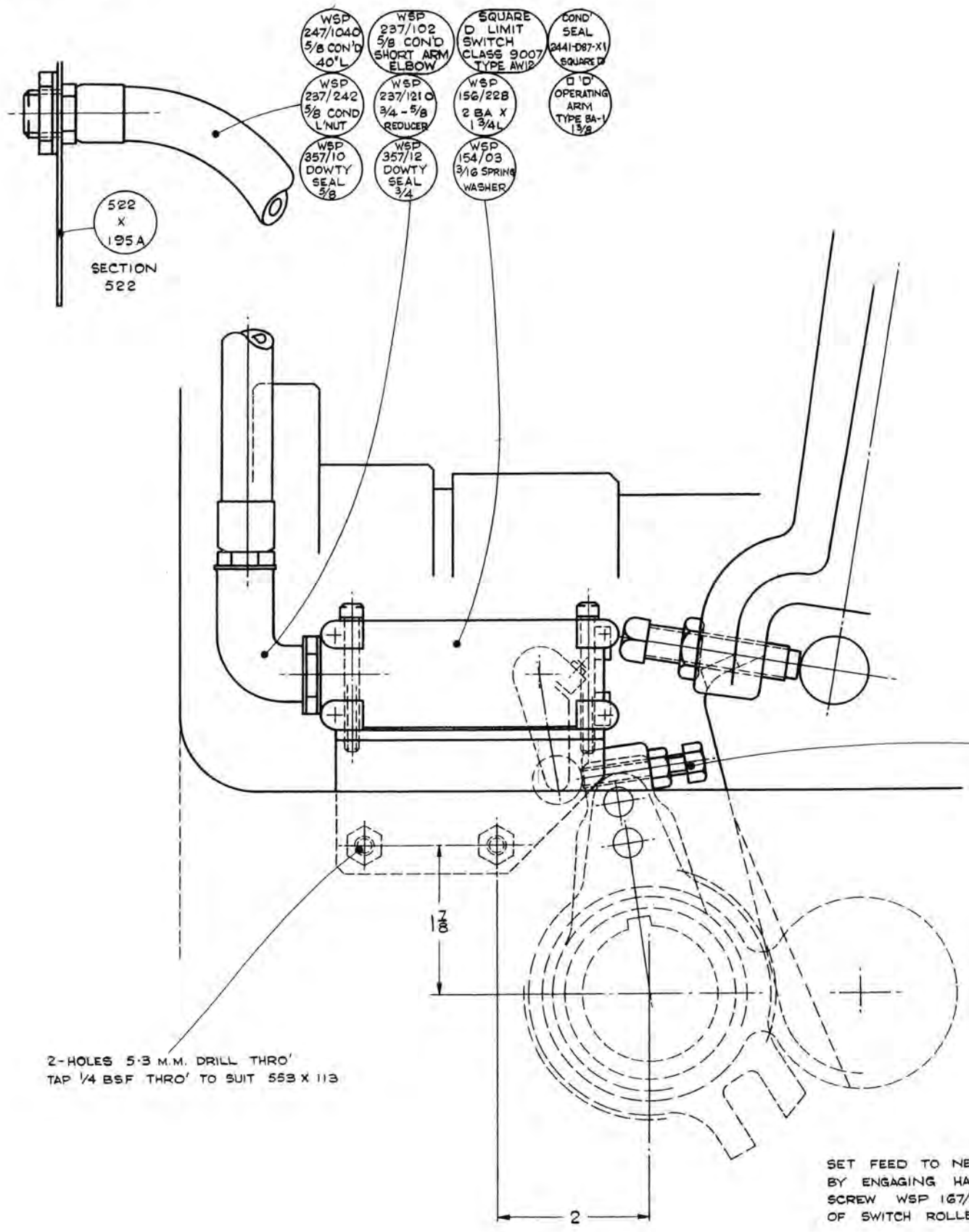

- 522 X 195 A SECTION 522
- WSP 247/1040 5/8 COND 40'L
- WSP 237/242 3/8 COND L'NUT
- WSP 857/10 DOWTY SEAL 5/8
- WSP 237/102 5/8 COND SHORT ARM ELBOW
- WSP 237/121 3/4 - 5/8 REDUCER
- WSP 357/12 DOWTY SEAL 3/4
- SQUARE D LIMIT SWITCH CLASS 9007 TYPE AW12
- WSP 156/228 2 BA X 1 3/4 L
- WSP 154/03 3/16 SPRING WASHER
- COND SEAL 2441-D87-X1 SQUARE D
- D 'D' OPERATING ARM TYPE SA-1 1 3/8
- 553 X 113
- WSP 167/0524 5/8 BSF 1 1/2 L
- WSP 203/05 5/16 BSF
- WSP 167/0412 1/4 BSF X 3/4 L
- WSP 198/8 1/4 LOCK W'SHR

SET FEED TO NEUTRAL POSITION BY ENGAGING HANDWIND & SET SCREW WSP 167/0524 1/8 CLEAR OF SWITCH ROLLER

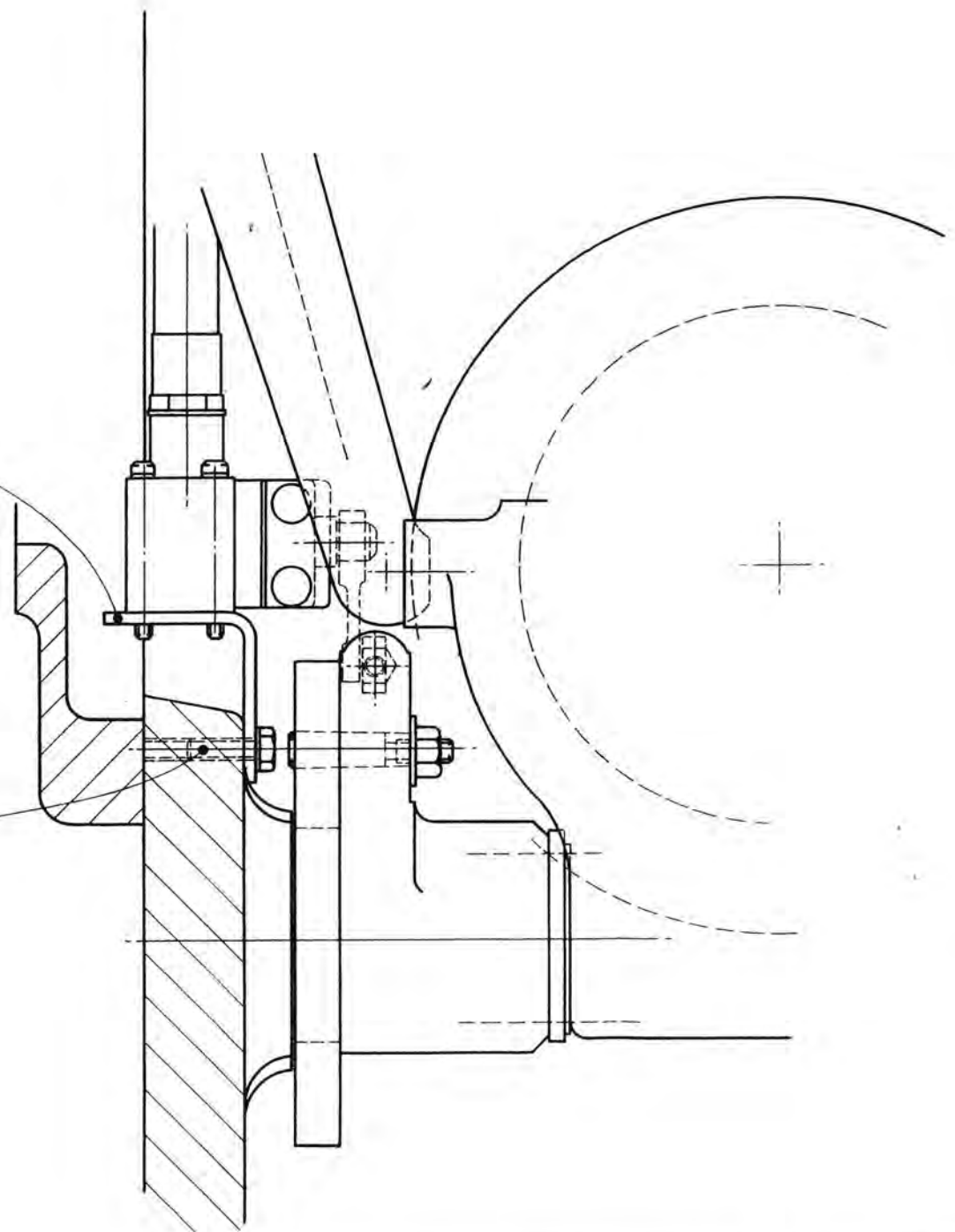

1/16" & 1/32" LIMIT HOLES TO B.S. 164: 1941.
REMOVE ALL SHARP CORNERS UNLESS OTHERWISE STATED.
TOLERANCE ON MACHINING DIMENSIONS ± .010 UNLESS OTHERWISE STATED.
AMERICAN PROJECTION
R = ROUGH MACHINE
FF = FINISH MACHINE
FFF = GRIND OR EQUIVALENT
RAW MATERIAL No.

WICKMAN MACHINE TOOL MANUFACTURING CO. LTD.
COVENTRY — ENGLAND

COPYRIGHT © THIS DRAWING AND DESIGN IS THE PROPERTY OF WICKMAN MACHINE TOOL MANUFACTURING CO. LTD., COVENTRY, ENGLAND AND IS CONFIDENTIAL. IT MUST NOT BE LOANED, COPIED OR OTHERWISE COMMUNICATED TO A THIRD PARTY WITHOUT PERMISSION AND IS SUBJECT TO RECALL AT ANY TIME.

DESCRIPTION

FEED BRAKE INTERLOCK

SCALE-	DRAWN	BRE	11-1-67	MATERIAL	553 A	2 5/8 - 6
FULL SIZE	CHECKED			553 L 11	"	3 1/4 - 6
	TRACED	JS	3-7-68		"	3 1/2 - 4
	TRACING CHECKED	BRE	9-7-68		"	4 1/8 - 4
					"	1 3/4 - 8
No. OFF	DRG. NO.	SECTION	MACHINE	MARK DRG. No. AT © DRG. No.		

553 Y 5A

FEED GEARING - DRAWING NO. 518 Z 1A

**Refer to drawing
showing all part
numbers**

<u>INDEX</u> <u>NO.</u>	<u>PART</u> <u>NO.</u>	<u>TITLE</u>
1	518X.220	Free Wheel Spring
2	518X.221	Free Wheel Plunger
3	---	5/8" dia. Roller, 5/8" long,
4	150/18	1.1/2" Slotted Locknut
5	176/0405	1/4" B.S.F. Socket Set Screw, Cup Point 5/16" long
6	153/04	Copper Pad 3/32" long
7	518X.196A	Worm Shaft Mitre Wheel
8	518X.157A	Adjusting Washer
9	262/45	Angular Contact Bearing 45 x 100 x 25mm
10	518X.113A	Bearing Housing
11	518X.189	Preload Spacer
12	518X.155A	Bearing Cap
13	155/0516	5/16" B.S.F. Socket Head Cap Screw 1" long
14	103/30	55mm External Circlip
15	518X.194B	Feed Mitre Wheel
16	518X.204	Key
17	518X.111A	Bearing Housing
18	55/0516	5/16" B.S.F. Socket Head Cap Screw 1" long
19	258/55	Light Ball Journal 55 x 100 x 21mm
20	153/04	Copper Pad 3/32" long
21	176/0405	1/4" B.S.F. Socket Set Screw Cup Point, 5/16" long
22	151/40	40mm Slotted Locknut
23	101/15	1.1/4" External Circlip
24	519X.172	Key for Sliding Gear
25	519X.189A	Handwind Sliding Gear
26	101/15	1.1/4" External Circlip
27	519X.182	Washer
28	236/242824	Oil Retaining Bush 1.1/2" bore x 1.1/4" od x 1.1/2" long
29	518X.113A	Bearing Housing
30	262/45	Angular Contact Bearing 45 x 100 x 25mm
31	203/16	1" B.S.F. Pinnacle Nut Type P. NP/F.324
32	518X.159A	Collar
33	518Y.137A	Worm Shaft
34	518Y.124	Worm Wheel
35	518X.218	Spacer
36	518X.204	Key
37	518Y.195A	Handwind Gear
38	518Y.166A	Brake Housing
39	258/55	Light Ball Journal 55 x 100 x 21mm
40	519X.188	Handwind Bevel Gear Shaft
41	518Y.131A	Feed Clutch Cup
42	104/42	100mm Internal Circlip
43	519X.112	Thrust Plate
44	518X.156	Bearing Sleeve
45	258/55Z.	Light Ball Journal 55 x 100 x 21mm. Three Dot Fit
46	518X.133A	Side Plate
47	518X.132A	Free Wheel body
48	518X.204	Key
49	518Y.154A	Final Feed Shaft
50	518Y.151A	Clutch Shaft
51	518X.136	Clutch Cup
52	518Y.152	Driving Sleeve
53	126/1013	5/16" Parallel Pin
54	258/65	Light Ball Journal 65 x 120 x 23mm

FEED GEARING - DRAWING NO. 518 Z 1A

<u>INDEX</u> <u>NO.</u>	<u>PART</u> <u>NO.</u>	<u>TITLE</u>
55	182/0824	1/2" B.S.F. Socket Set Screw, Taper Point 1.1/2" long
56	173/08	1/2" B.S.F. Hexagon Nut
57	518Y.153	Bearing Sleeve
58	518Y.135A	Fast Motion Clutch Cup
59	154/05	5/16" Spring Washer
60	126/1020	5/16" Parallel Pin 1.1/4" long
61	155/0520	5/16" B.S.F. Socket Head Cap Screw 1.1/4" long
62	518X.109A	Spacer
63	518X.143	Spacer
64	518X.108	Spacer
65	518Y.170A	Fast Motion Sprocket
66	258/45Z	Light Ball Journal 45 x 85 x 19mm. Three Dot Fit.
67	104/39	85mm Internal Circlip
68	518X.213	Locating Clamp Ring
69	518X.107A	Bearing Housing
70	155/0516	5/16" B.S.F. Socket Head Cap Screw 1" long
71	154/05	5/16" Spring Washer
72	518X.205	Key
73	18Y.193A	Gear
74	182/0610	3/8" B.S.F. Socket Set Screw, Taper Point 5/8" long
75	---	Wire Ring
76	518X.164	Gear Centre
77	150/38	5/16" B.S.F. Slotted Locknut
78	176/0506	5/16" B.S.F. Socket Set Screw, Cup Point 3/8" long
79	153/05	5/16" Soft Pad 1/8" long
80	518X.169	Jockey Sprocket
81	236/162024	Oil Retaining Bush 1" bore x 1.1/4" o/d x 1.1/2" long
82	518X.163	Jockey Eccentric
83	518X.197	Collar for Jockey Sprockets
84	203/12L	1/4" B.S.F. Pinnacle Nut NT/F.244
85	518X.167	Upper Drive Sprocket
86	518X.215	Bearing Housing
87	155/0524	5/16" B.S.F. Socket Head Cap Screw 1.1/2" long
88	154/05	5/16" Spring Washer
89	518X.209	Key
90	150/32	5/16" B.S.F. Slotted Locknut
91	176/0506	5/16" B.S.F. Socket Set Screw, Cut Point 3/8" long
92	153/05	5/16" Soft Pad 1/8" long
93	257/40	Medium Ball Journal 40 x 90 x 23mm
94	151/40	40mm Slotted Locknut
95	76/0405	1/4" B.S.F. Socket Set Screw, Cup Point 5/16" long
96	153/04	1/4" Soft Pad 5/32" long
97	518X.206	Key
98	518X.110A	Clamp Plate
99	155/0516	5/16" B.S.F. Socket Head Cap Screw, 1" long.
100	154/05	5/16" Spring Washer
101	518X.214	Clamping Ring
102	518X.212	Clamping Ring
103	155/0516	5/16" B.S.F. Socket Head Cap Screw 1" long
104	154/05	5/16" Spring Washer
105	518Y.127B	Slipping Clutch Body
106	568X.178	Plug

FEED GEARING - DRAWING NO. 518 Z 1A

<u>INDEX</u> <u>NO.</u>	<u>PART</u> <u>NO.</u>	<u>TITLE</u>
107	168X.160	Oil Bush
108	568X.162	Oil Nipple
109	178/0616	3/8" B.S.F. Socket Set Screw, Half-Dog Point 1" long
110	150/22	1/4" B.S.F. Slotted Locknut
111	176/0405	1/4" B.S.F. Socket Set Screw, Cup Point 5/16" long
112	153/04	1" Soft Pad 5/32" long
113	518X.219	Spacer
114	257/45	Medium Ball Journal 45 x 100 x 25mm
115	104/42	100mm Internal Circlip
116	8X.129B	Drive Member
117	518X.191	Input Driven Gear
118	---	See Table
119	518Y.145	Shaft
120	258/40	Light Ball Journal 40 x 80 x 18mm
121	104/3B	80mm Internal Circlip
122	518X.103	Bearing Housing
123	155/0516	5/16" B.S.F. Socket Head Cap Screw 1" long
124	151/40	40mm Slotted Locknut
125	176/0405	1/4" B.S.F. Socket Set Screw, Cup Point 5/16" long
126	153/04	1/4" Soft Pad 5/32" long
127	104/38	80mm Internal Circlip
128	258/40	Light Ball Journal 40 x 80 x 18mm
129	518X.201	Key
130	159/408	4 B.A. Socket Countersunk Screw 1/2" long
131	NT/F.244	3/4" B.S.F. Pinnacle Nut
132	518X.148	Washer
133	518X.207	Key
134	258/50	Light Ball Journal 50 x 90 x 20mm
135	518X.101	Bearing Housing
136	155/0516	5/16" B.S.F. Socket Head Cap Screw 1" long
137	518X.168	Worm Shaft Sprocket
138	518Y.138A	Worm Shaft
139	150/20	1/4" Slotted Locknut
140	76/0405	1/4" B.S.F. Socket Set Screw, Cup Point 5/16" long
141	153/04	1/4" Soft Pad 3/32" long
142	257/35	Medium Ball Journal 35 x 80 x 21mm
143	518X.116A	Bearing Housing
144	155/0412	1/4" B.S.F. Socket Head Cap Screw 3/4" long
145	154/04	1/4" Spring Washer
146	518X.202	Key
147	262/40	Medium Ball Journal, Angular Contact 40 x 90 x 23mm
148	518X.190	Preload Spacer
149	518X.140	Bearing Housing
150	518X.160A	Spacer
151	518Y.126	Input gear Sleeve
152	518Y.165	Feed Input Sprocket

FEED GEARING - DRAWING NO. 518 Z 1A

<u>INDEX</u> <u>NO.</u>	<u>PART</u> <u>NO.</u>	<u>TITLE</u>
153	155/0520	5/16" B.S.F. Socket Head Cap screw 1.1/4" long
154	154/05	5/16" Spring Washer
155	141/2220	11/32" Extractable Taper Dowel 1.1/4" long
156	257/30	Medium Ball Journal 30 x 72 x 19mm
157	258/50	Light Ball Journal 50 x 90 x 20mm
158	518X.104	Bearing Sleeve
159	182/0612	3/8" B.S.F. Socket Set Screw, Taper Point 3/4" long
160	518X.216	Spacer
161	518X.217	Spacer
162	103/19	30mm External Circlip
163	518X.128A	Keyed Sleeve
164	518X.203A	Key
165	518X.102	Bearing Sleeve
166	82/0612	3/8" B.S.F. Socket Set Screw, 1/4" long
167	518Y.187A	Slipping Clutch Body (Feed Motion)
168	518X.208	Key
169	518X.188	Overload Clutch Spring
170	118X.141	Spring Retaining Plug
171	518X.199A	Plunger
172	518X.130C	Feed Motion Drive Member
173	518Y.125A	Upper Worm Wheel
174	262/40	Medium Ball Journal Angular Contact 40 x 90 x 23mm
175	518X.117A	Bearing Housing
176	518X.161A	Washer
177	NP/F.324	1" B.S.F. Pinnacle Nut
178	518Y.146A	Shaft
179	518X.147A	Spacer
180	257/35	Medium Ball Journal 35 x 80 x 21mm
181	---	See Table
182	103/21	35mm External Circlip
183	518X.201	Key
184	159/408	4 B.A. Socket Countersunk Screw 1/2" long
185	518X.148	Washer
186	NT/F.244	3/4" B.S.F. Pinnacle Nut
187	518X.144A	Locking Pin
188	518X.122A	Bearing
189	518X.106	Bearing Housing
190	103/23	40mm External Circlip
191	258/40	Light Ball Journal 40 x 80 x 18mm
192	51BY.149A	Shaft
193	104/38	80mm Internal Circlip
194	150/22	1.3/8" Slotted Locknut
195	176/0405	1/4" B.S.F. Socket Set Screw, Cup Point 5/16" long
196	153/04	1/4" B.S.F. Soft Pad 5/32" long
197	518Y.192A	Gear
198	182/0610	3/8" B.S.F. Socket Set Screw, Taper Point, 5/8" long
199	---	Wire Ring

FEED GEARING - DRAWING NO. 518 Z 1A

<u>INDEX</u> <u>NO.</u>	<u>PART</u> <u>NO.</u>	<u>TITLE</u>
200	518X.205	Key
201	182/0616	3/8" B.S.F. Socket Set Screw, Taper Point 1" long
202	568X.161A	Oil Nipple Holder
203	568X.162	Oil Nipple
204	168X.160	Oil Bush
205	NT/F.324	1" B.S.F. Pinnacle Nut
206	518X.142A	Collar
207	182/0824	1/2" B.S.F. Socket Set Screw, Taper Point, 1.1/2" long
208	173/08L	1/2" B.S.F. Hexagon Locknut
209	257/35	Medium Ball Journal 35 x 80 x 21mm.

FEED GEARING

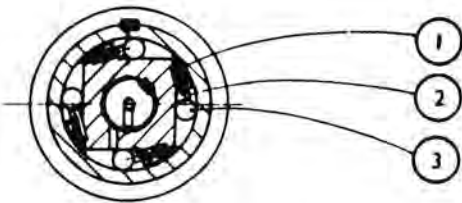

SECTION AA

LIST OF AVAILABLE FEED GEARS B.D.P. 20° PA.

5T	58 x 17	37T	58 x 177
6T	58 x 172	39T	58 x 178
7T	58 x 173	42T	58 x 179
20T	58 x 174	44T	58 x 180
30T	58 x 175	47T	58 x 181
34T	58 x 176	52T	58 x 182

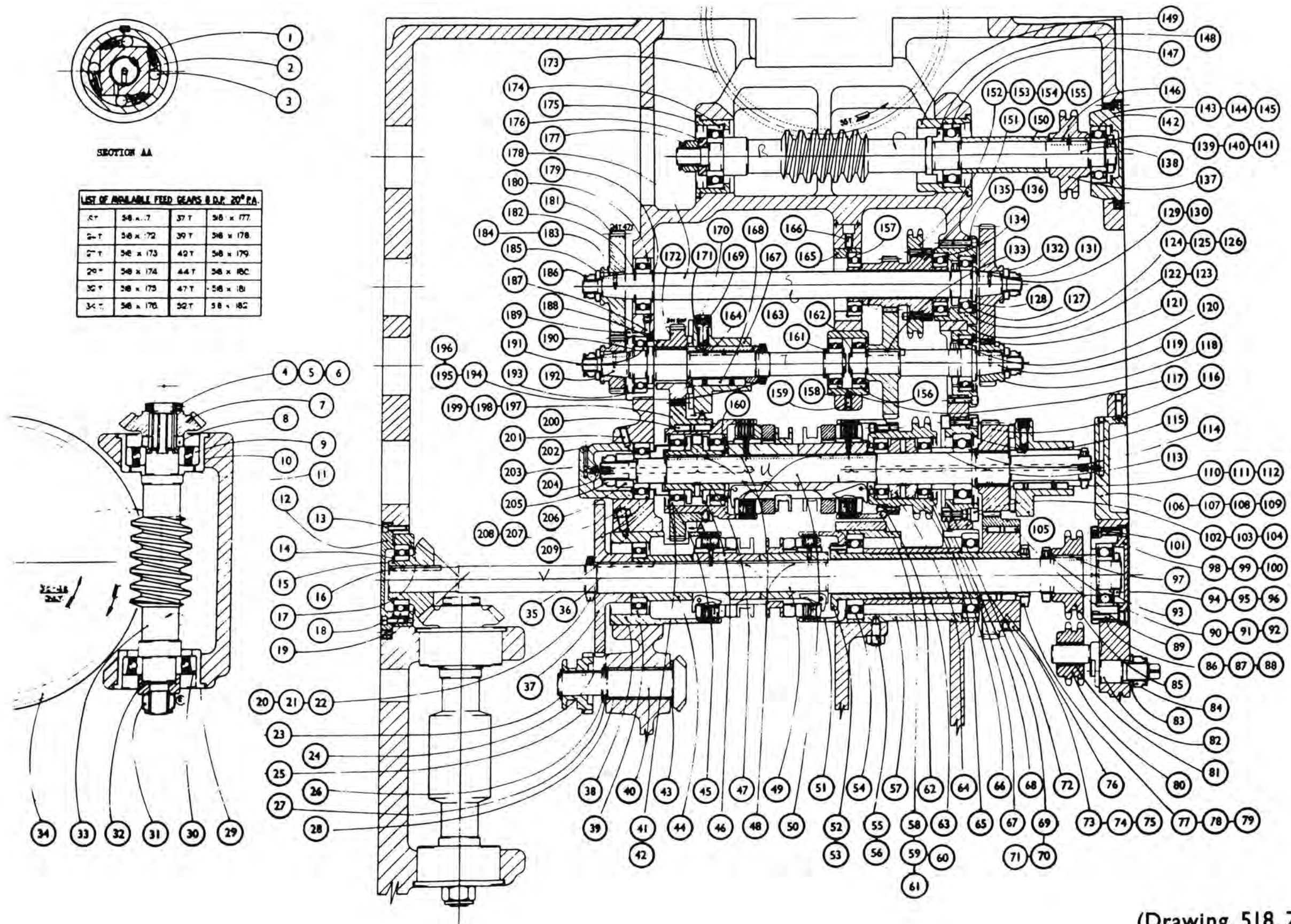

(Drawing 518 Z I A)

INDEX CLUTCH OPERATION - DRAWING NO. 545 Z 1

<u>INDEX NO.</u>	<u>PART NO.</u>	<u>TITLE</u>
1	155/0612	3/8" B.S.F. Socket Head Cap Screw 3/4" long
2	125/1216	3/16" Taper Pin, 1" long
3	125/2240	11/32" Taper Pin 2.1/2" long
4	154/07	7/16" Spring Washer
5	155/0720	7/16" B.S.F. Socket Head Cap Screw 1.1/4" long
6	545Y.105A	Clutch Lever Bracket
7	5Y.106	Clutch Lever
8	125/1220	3/16" Taper Pin 1.1/4" long
9	545X.110	Spring for Plunger
10	545X.107	Bush
11	545X.108	Plunger
12	125/1220	3/16" Taper Pin 1.1/4" long
13	545X.109	Plunger Handle
14	545X.104A	Clutch Operating Shaft
15	545X.112	Fulcrum Stud
16	545X.111	Baulking Strip
17	545X.103	Clutch Fork Pin
18	545Y.101A	Clutch Fork
19	125/2236	11/32" Taper Pin 2.1/4" long
20	545Y.102	Clutch Fork Bracket
21	155/0848	1/2" B.S.F. Socket Head Cap Screw, 3" long
22	154/08	1/2" Spring Washer

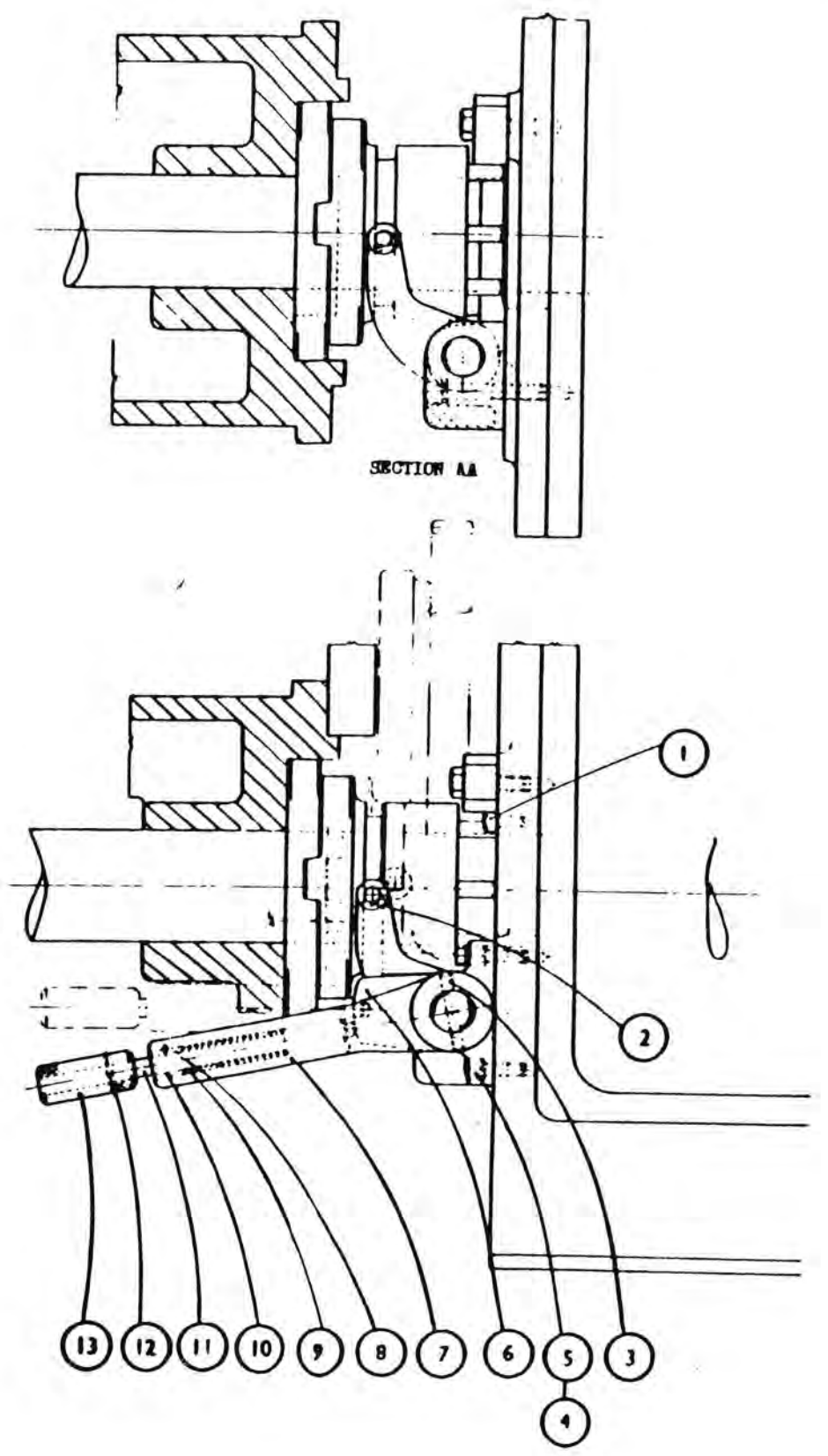
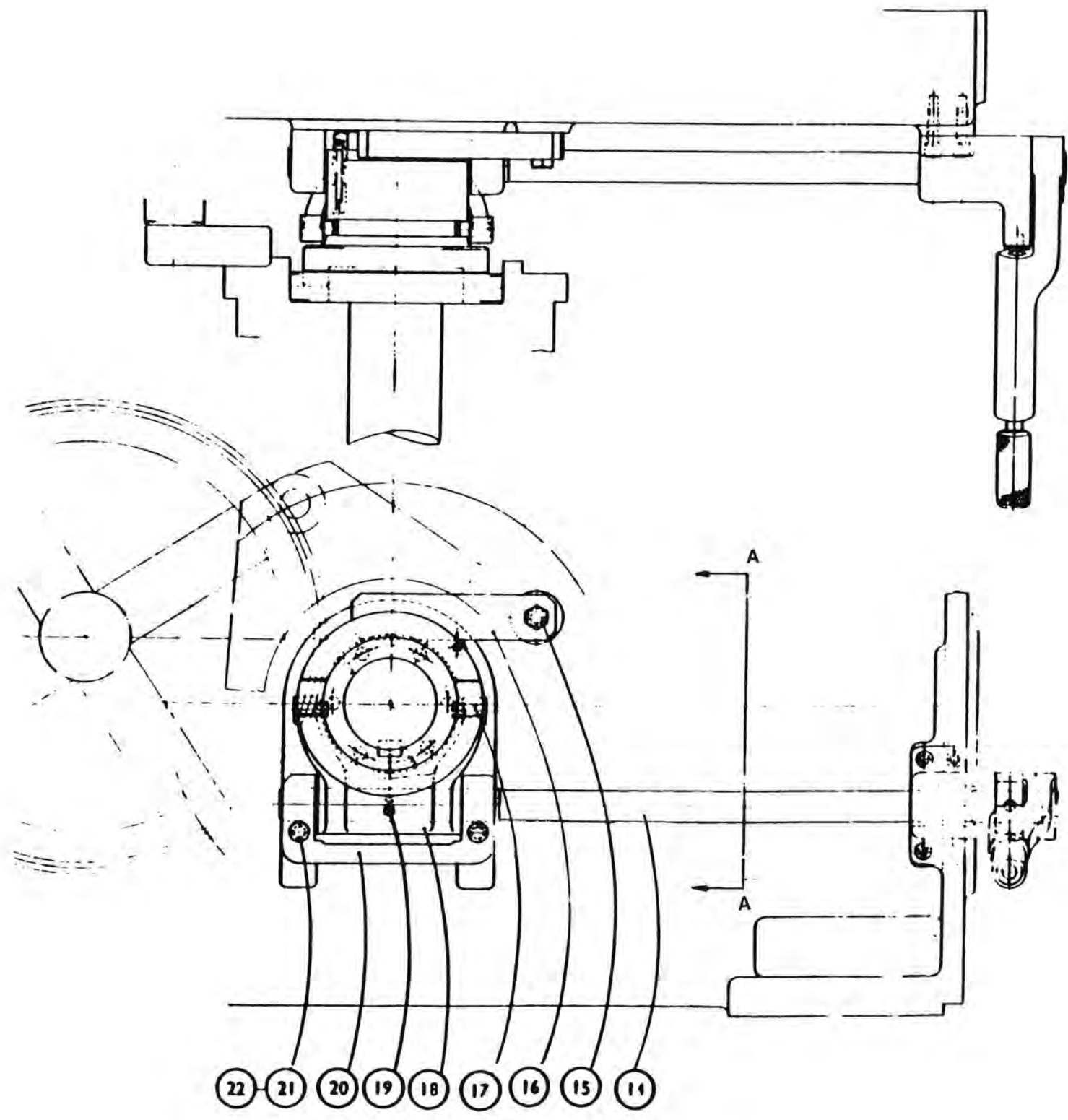

545Z1

INDEXING GEARS - DRAWING NO. 548-Z 1

<u>INDEX NO.</u>	<u>PART NO.</u>	<u>TITLE</u>
1	173/08	1/2" B.S.F. Hexagon Nut
2	182/0828	1/2" B.S.F. Socket Head Set Screw, Taper Point 1.3/4" long
3	182/0816	1/2" B.S.F. Socket Head Set Screw, Taper Point 1" long
4	236/364440	Oil Retaining Bush 2.1/4" x 2.3/4" x 2.1/2" long
5	548Y.103	Indexing Gear
6	236/283636	Oil Retaining Bush 1.3/4" x 2.1/4" x 2.1/4" long
7	546Y.108A	Upper Indexing Gear
8	236/364432	Oil Retaining Bush 2.1/4" x 2.3/4" x 2" long
9	547Y.102A	Intermediate Indexing Gear
10	54/08	1/2" Spring Washer
11	155/0828	1/2" B.S.F. Socket Head Cap Screw 1.3/4" long
12	546X.104	Pin for Geneva Wheel
13	125/3236	1/2" Taper Pin, 2.1/4" long
14	548Y.102	Geneva Wheel Gear
15	548Y.101	Geneva Wheel
16	154/08	1/2" Spring Washer
17	155/0828	1/2" B.S.F. Socket Head Cap Screw 1.3/4" long
18	546X.104	Pin for Geneva Wgheel
19	546Y.103	Geneva Wheel Bearing
20	125/3236	1/2" Taper Pin 2.1/4" long
21	155/0840	1/2" B.S.F. Socket Head Cap Screw, 2.1/2" long
22	154/08	1/2" Spring Washer
23	546Y.105A	Indexing Shaft
24	236/404844	Oil Retaining Bush 2.1/2" x 3" x 2.3/4" long
25	546X.115	Gear Centre
26	155/0620	3/8" B.S.F. Socket Head Cap Screw 1.1/4" long
27	154/06	3/8" Spring Washer
28	212/18	1/8" B.S.P. Grease Nipple
29	210/2525	Indicator Washer, Yellow
30	125/3222	1/2" Taper Pin 1.3/8" long
31	546Y.106A	Stock Indexing Gear
32	522Z.102	Stock Carriage Indexing Bracket
33	155/0832	1/2" B.S.F. Socket Head Cap Screw 2" long
34	155/0616	3/8" B.S.F. Socket Head Cap Screw 1" long
35	154/06	3/8" Spring Washer
36	522Y.133A	Pinion Cover
37	155/0828	1/2" B.S.F. Socket Head Cap Screw 1.3/4" long
38	154/08	1/2" Spring Washer
39	546X.107A	Locking Washer
40	547Y.113A	Indexing Gear Guard
41	158/0410	1/4" B.S.F. Countersunk Head Screw 5/8" long
42	155/1032	5/8" B.S.F. Socket Head Cap Screw 2" long
43	139/17	1/2" Taper Pin 2.1/4" long
44	522Z.103	Indexing Gear Bracket
45	523X.104	Roller for Centre Quadrant
46	544X.139	Roller Pin
47	212/18	1/8" B.S.P. Grease Nipple
48	210/2525	Indicator Washer, Yellow
49	125/2236	11/32" Taper Pin 2.1/4" long
50	141/22	5/8" Taper Pin 3" long
51	544Y.124	Geneva Arm
52	155/1232	3/4" B.S.F. Socket Head Cap Screw 2" long
53	154/12	3/4" Spring Washer

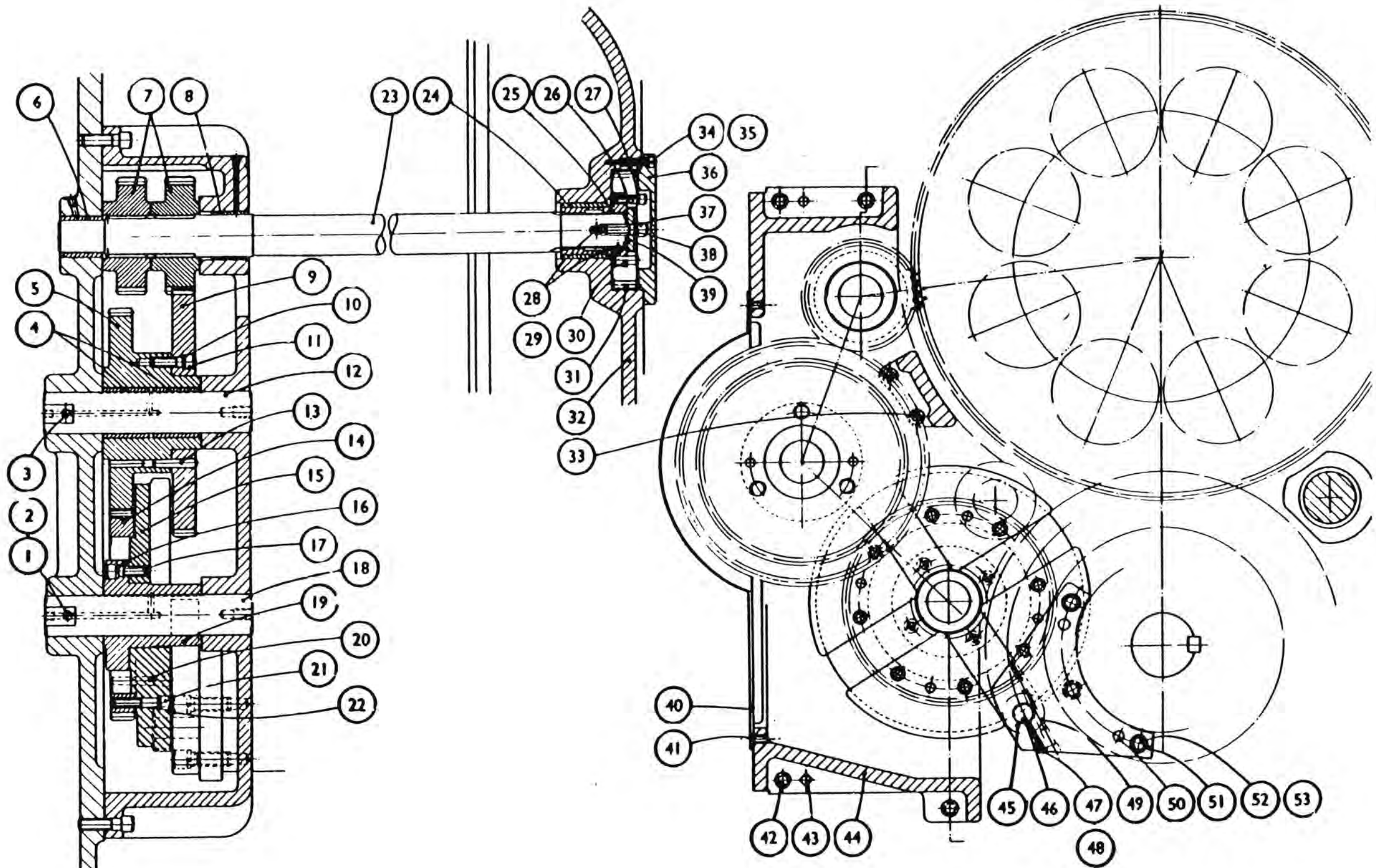

LONGITUDINAL MOTION - DRAWING NO. 523 Z 1A

<u>INDEX</u> <u>NO.</u>	<u>PART</u> <u>NO.</u>	<u>TITLE</u>
1	155/1236	3/4" B.S.F. Socket Head Cap Screw, 2.1/4" long
2	154/12	3/4" Spring Lockwasher
3	139/15	Headed Taper Dowel, 1.7/8" long
4	523Y.106A	Scale for Centre Quadrant, Metric
5	523Y.105A	Scale for Centre Quadrant, English
6	524Y.103A	Scale for Quadrant, Metric
7	524Y.102A	Scale for Quadrant, English
8	523Y.107	Quadrant Bracket
9	523X.109	Bearing Pin for Centre Quadrant
10	523X.110	Bush for Quadrant
11	154/10	5/8" Spring Steel Washer
12	523X.108	Special Bolt
13	524X.106	Bearing Pin for Outer Guard
14	572X.118	Instruction Plate for Scale Reading
15	165/204	2 B.A. Round Head Screw, 1/4" long
16	524Y.102A	Scale for Quadrant, English - 6-Spindle Machine
17	524Y.103A	Scale for Quadrant, Metric - 6-Spindle Machine
18	524Y.116A	Scale for Independent Quadrant, English - 4-Spindle Machine
19	524Y.117A	Scale for Independent Quadrant, Metric - 4-Spindle Machine
20	518Y.125A	Upper Worm Wheel
21	143/1016	5/16" diameter G.P.4. Grooved Dowel 1" long
22	519X.102B	Extension
23	155/1092	5/8" B.S.F. Socket Head Cap screw, 5.3/4" long.
24	154/10	5/8" x 22 T.P.I. Slotted Locknut
25	519Y.106A	Coupling Disc
26	155/1044	5/8" B.S.F. Socket Head Cap Screw, 2.1/2" long
27	154/10	5/8" x 22 T.P.I. Slotted Locknut
28	519X.107	Back Plate
29	520X.108	Cam Ring

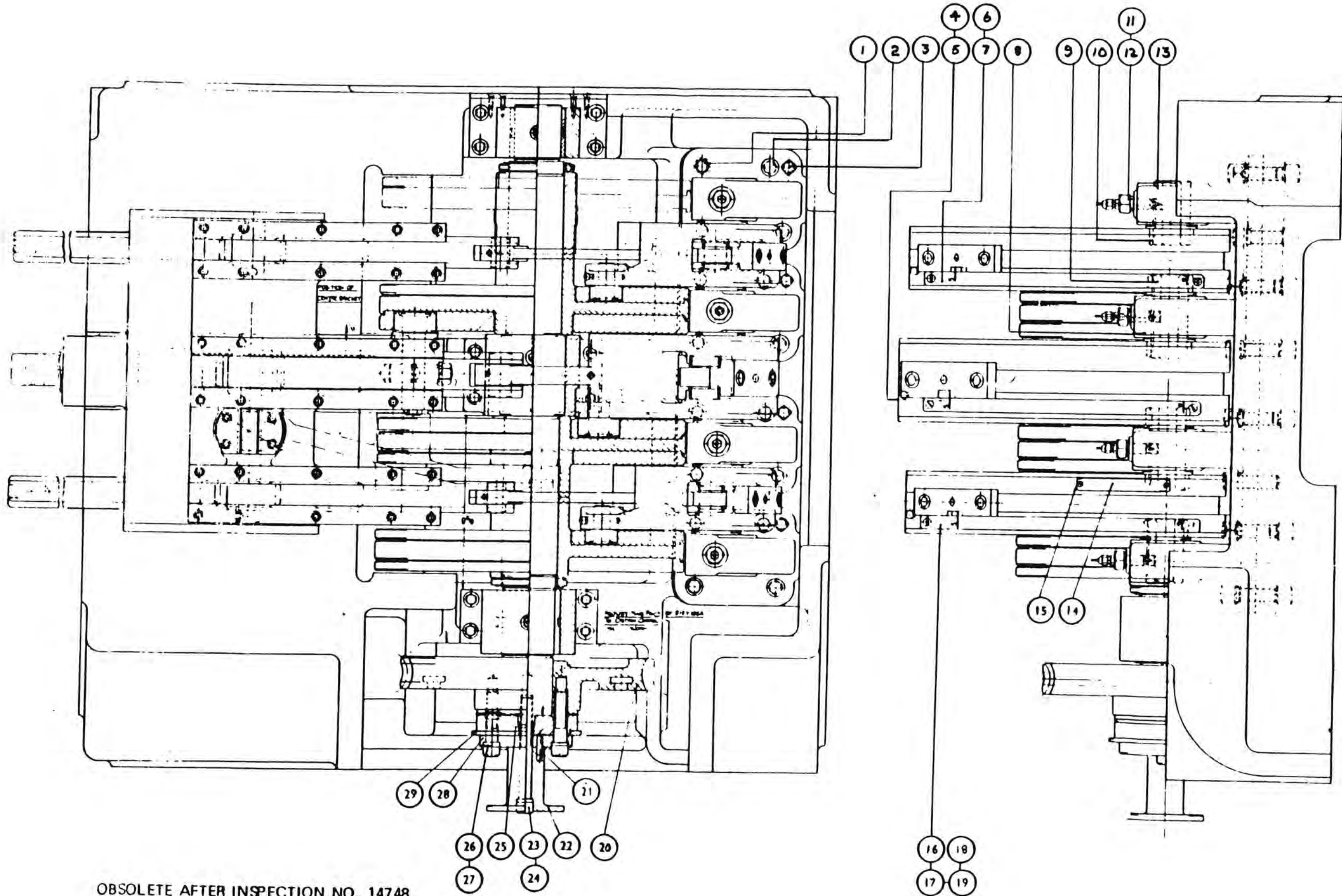

523Z1A

SUPERSEDES
523Z 1A
SUPERSEDED BY

ALTERATIONS

ISSUED/FILMED
500 A 591
RER 18-G-70

(A) 500 A 603
RER 18-G-73

(B) 500 A 653
Jg. Nov. 79

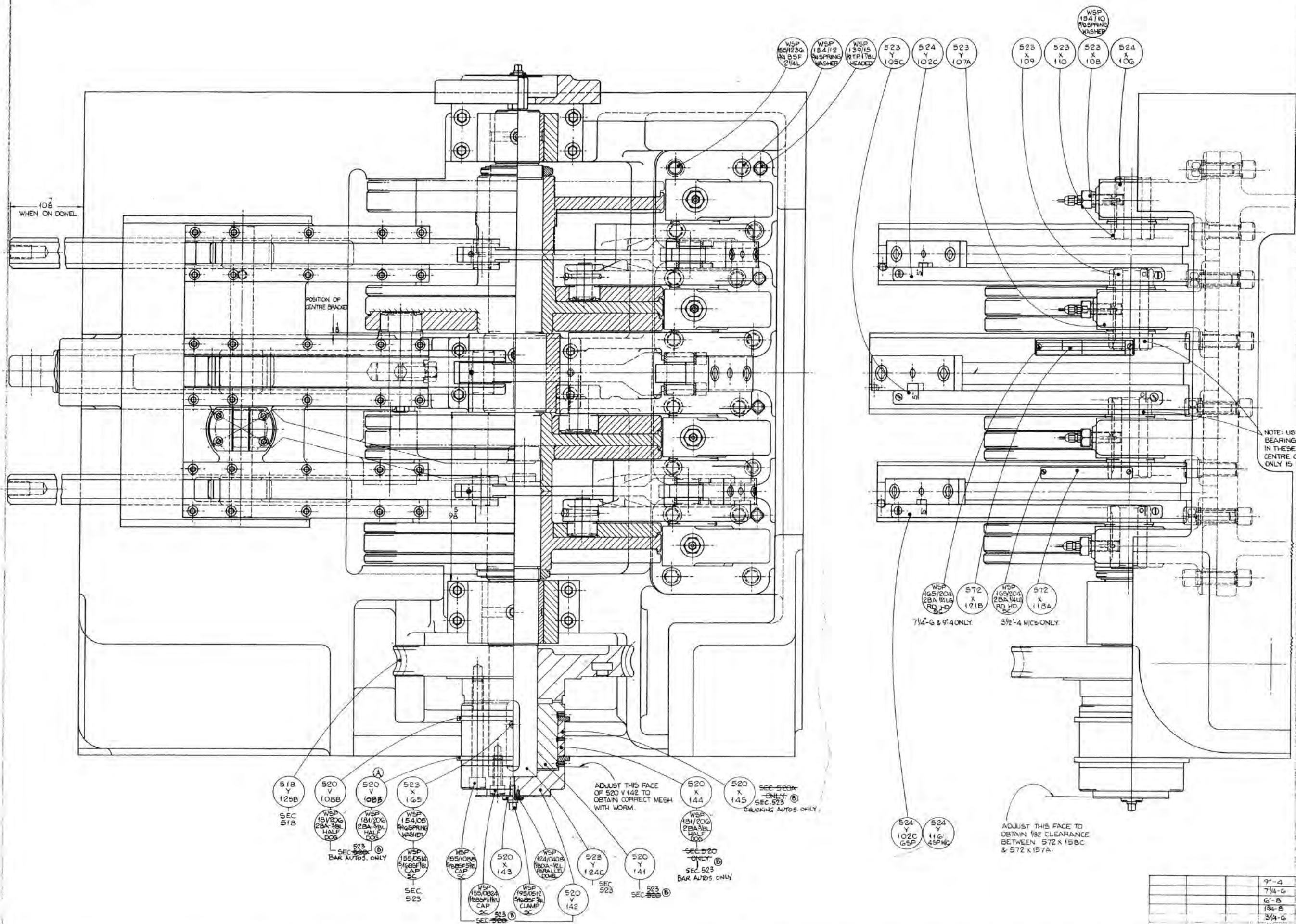

9-4
7/4-G
G-B
184-B
3/4-G
4/8-4
3/2-4
29/8-G

LONGITUDINAL MOTION, CENTRE QUADRANT - DRAWING NO. 523 Z 2

<u>INDEX</u> <u>NO.</u>	<u>PART</u> <u>NO.</u>	<u>TITLE</u>
1	522Z.104	Beam
2	523Z.101	Sliding Block
3	523Y.120	Bottom Rack
4	423X.122	Centre Pinion
5	523X.150	Guide Strips
6	154/06	3/8" diameter Spring Washer
7	155/0620	3/8" B.S.F. Socket Head Cap screw, 1.1/4" long
8	523Y.119	Top Centre Rack
9	523X.146	Roller for Sliding Block
10	523X.145	Eccentric Pin for Sliding Block Roller
11	523X.148A	Lockbolt
12	523X.147A	Lockbolt Bush
13	154/10	5/8" diameter Spring Washer
14	173/10	5/8" B.S.F. Hexagon Nut
15	182/0416	1/4" B.S.F. Socket Set Screw, Taper Point, 1" long
16	73/04L	1/4" B.S.F. Locknut
17	523X.118	Centre Rack Pin (Upper Rack)
18	139/11	Lead Taper Dowel, 2.1/8" long
19	523.103	Roller Pin for Centre Quadrant
20	523X.104	Roller for Centre Quadrant
21	523Z.102	Centre Quadrant
22	523Y.116	Centre Quadrant Link
23	523X.115	Link Bush
24	523X.114	Pin for Link
25	523X.113	Locking Pad for Centre Quadrant
26	154/04	1/4" diameter Spring Washer
27	155/0408	1/4" B.S.F. Socket Head Cap Screw, 1/2" long
28	523Y.111	Stroke Adjusting Block
29	154/06	3/8" diameter Spring Washer
30	155/1036	5/8" B.S.F. Socket Head Cap Screw, 2.1/4" long
31	212/18	1/8" B.S.P. Grease Nipple
32	182/0616	1/8" B.S.F. Socket Set Screw, Taper Point 1" long
33	154/06	3/8" diameter Spring Washer
34	155/0620	3/8" B.S.F. Socket Head Cap Screw, 1.1/4" long
35	523X.141	Locator for Sliding Block
36	523X.140	Lockbolt
37	523X.143	Bush for Lockbolt
38	154/05	5/16" Spring Washer
39	155/0528	5/16" B.S.F. Socket Head Cap Screw, 1.1/4" long
40	523X.144A	Spring Cap for Lockbolt
41	523X.142	Spring for Lockbolt
42	523X.160	Gasket
43	182/0820	1/2" B.S.F. Socket Set Screw, Taper Point 1.1/4" long
44	620	3/8" B.S.F. Socket Head Cap Screw, 1.1/4" long
45	154/06	3/8" Spring Washer
46	523X.151	Guide Strip - Lower
47	164/0408	1/4" B.S.F. Round Head Set Screw, 1/2" long

THIS NUT MUST BE WELL TIGHTENED.

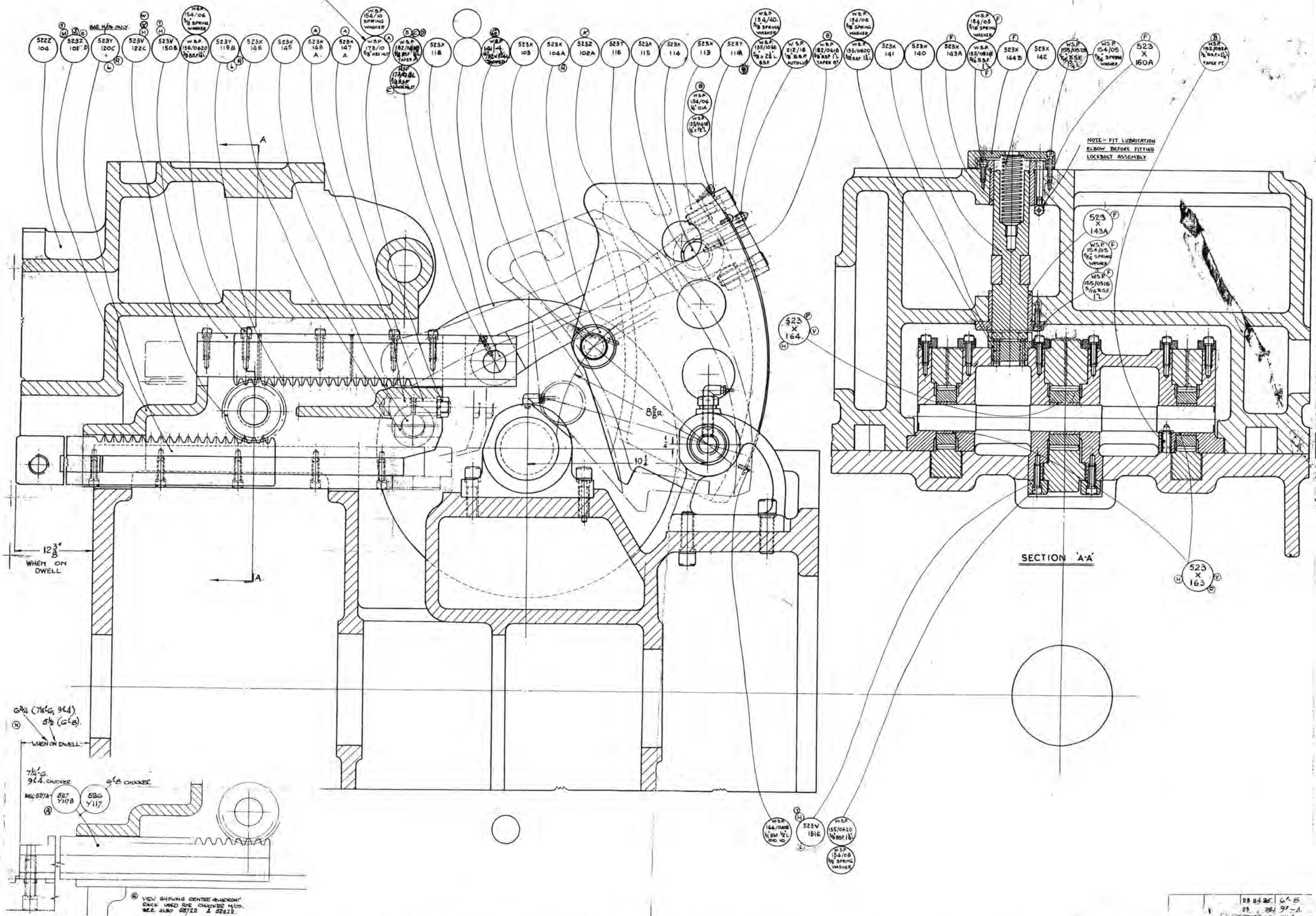

- A. ALT. NO. 6549 04 13030
- B. ALT. NO. 6368 28 1 51. PW
- C. 500A142 J&H 123-53
- D. 500A122 9/12/58
- E. 500A178 RES. S. 2-52
- F. 500A222 3-11-54
- G. ALT. 500A257 RES. 21-C-55.
- H. 500A 509 BTP 10-4-50
- I. 500A365 BTP 25-6-50
- J. 500A400 274 28-8-58
- K. 500A 408 174 18-1-59
- L. 500A387 PW 4-12-53
- M. 500A407 RES. 1 C. 60
- N. 500A428 BTP 29-12-60
- O. 500A471 174 27-8-52
- P. 500A 471 174 27-8-52
- Q. 500A 524 GNF 14-3-67
- R. 500A 536 GNF 8-9-67
- S. 500A 380 FG 24-1-48
- T. 500A 456 B.C. 18 DEC 68
- U. 500A 639 SW 6-4-81

NOTE - FIT LUBRICATION ELBOW BEFORE FITTING LOCKBOLT ASSEMBLY.

SECTION A-A

0.001 (7/16 G, 9/64) 5/16 (G.C.B.)

7/16 G 9/64 CHUCKER

VIEW SHOWING CENTRE QUADRANT DACK USED FOR CHUCKER M.C.S. SEE ALSO 52722 & 52822.

LONGITUDINAL MOTION. CENTRE QUADRANT MECHANISM.

HALF SIZE D.C.F. 20-8-48 11-1-50 15-8-48

28 24 25 G.C.S.
28 25 91-1
28 25 25 744 G

IND/T 251A-52

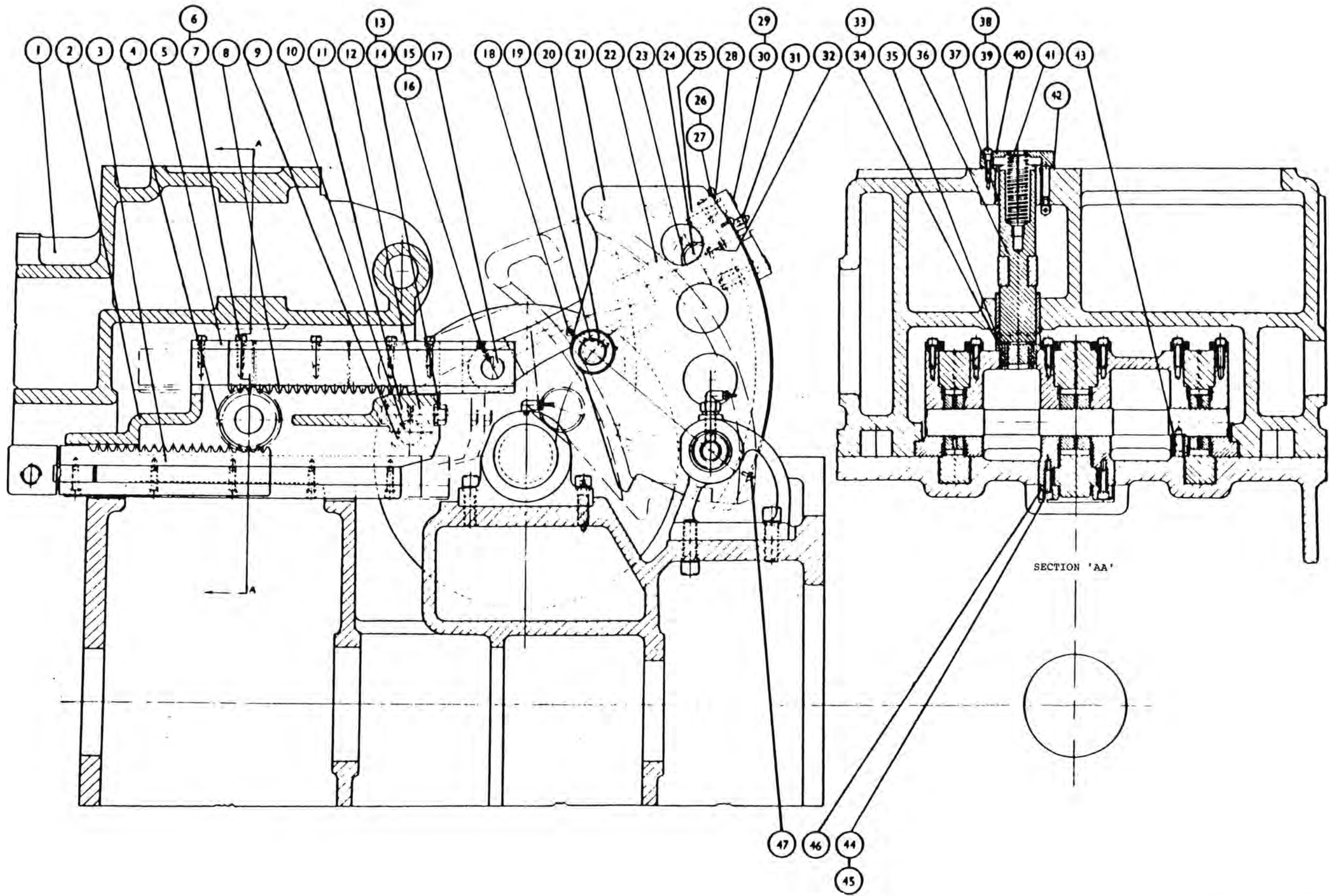

523Z2

LONGITUDINAL MOTION, FRONT AND REAR QUADRANTS - DRAWING NO. 523 Z 3

<u>INDEX</u> <u>NO.</u>	<u>PART</u> <u>NO.</u>	<u>TITLE</u>
1	143/1214C	Mills Grooved Pin 3/8" x 7/8" long, type G.P.3.
2	523X.138	Bush (Lockbolt Fulcrum Pin)
3	523X.139	Washer (Locknut Fulcrum Pin)
4	173/16L	1" B.S.F. Hexagon Locknut
5	523Y.136	Fulcrum Pin (for Lockbolt)
6	523X.134	Roller Pin
7	523X.135	Roller
8	125/1832	9/32" Taper Pin, 2" long
9	523Y.133	Lockbolt Lever
10	139/4	Headed Taper Dowel 1.9/16" long
11	523X.135	Roller
12	523X.134	Roller Pin
13	524Z.101	Quadrant (Rear)
14	524Y.105	Link (Independent Quadrant)
15	524X.107	Locking Pin
16	524Y.104	Stroke Adjusting Block (Outer)
17	182/0616	3/8" B.S.F. Socket Set Screw, Taper Point 1" long
18	154/08	1/2" diameter Spring Washer
19	155/0836	1/2" B.S.F. Socket Head Set Screw 2.1/2" long
20	161/0412	1/4" B.S.F. Countersunk screw, Slotted, 3/4" long
21	523X.132	Cover (on Rear Bearing Bracket)
22	523X.127	Rear Bearing for Camshaft
23	523Y.131	Camshaft Rear Bearing Bracket
24	150/48	3" diameter Slotted Locknut
25	176/0506	5/16" B.S.F. Socket Set Screw, Cup Point 3/8" long
26	153/05	Copper Pad 1/8" long
27	523X.128	Spacing Bush
28	523X.125	Key for Camshaft
29	523X.159	Special Screw for Cams
30	126/2024	5/8" Parallel Pin, 1.1/2" long
31	524Z.114	Cam for Longitudinal Slide
32	523Z.152	Cam Carrier
33	523Z.154	Cam, Sliding Block, 3.1/2" stroke
34	523Z.155	Cam, Sliding Block, 5" stroke
35	523Y.129	Camshaft Centre Bearing Bracket
36	523X.158	Special Screw for Cams
37	154/08	1/2" diameter Spring Washer
38	523Z.156	Cam, Centre Block
39	126/2028	5/8" Parallel Pin, 1.3/4" long
40	523Z.153	Cam Carrier
41	523Z.157	Cam Lockbolt
42	523X.159	Special Screw for Cams
43	126/2024	5/8" Parallel Pin, 1.1/2" long
44	524Z.114	Cam for Longitudinal Slide
45	523Z.161	Cam Carrier
46	-	Cams for 6th Station Attachments 2.5/8"-6
47	150/48	3" diameter Slotted Locknut
48	153/05	Copper Pad 1/8" long
49	176/0506	5/16" B.S.F. Socket Set Screw, Cup Point 3/8" long
50	523Y.130	Camshaft, Front Bearing Bracket
51	523X.126	Front Bearing for Camshaft.
52	523Y.124	Cam Shaft
53	126/2024	5/8" Parallel Pin, 1.1/2" long
54	523X.159	Special Screw for Cams

**Refer to drawing
showing all part
numbers**

LONGITUDINAL MOTION, FRONT AND REAR QUADRANTS - DRAWING NO. 523 Z 3

<u>INDEX</u> <u>NO.</u>	<u>PART</u> <u>NO.</u>	<u>TITLE</u>
55	139/11	Headed Taper Dowel, 2.1/8" long
56	523X.158	Special Screw for Cams
57	126/2028	5/8" Parallel Pin, 1.3/4" long
58	154/08	1/2" diameter Spring Washer
59	24X.108	Bush for Link
60	524X.109	Pin for Link, Quadrant End.
61	155/0408	1/4" B.S.F. Socket Head Cap Screw 1/2" long
62	154/04	1/4" diameter Spring Washer
63	164/0408	1/4" B.S.F. Round Head Set Screw 1/2" long
64	155/036	5/8" B.S.F. Socket Head
65	154/10	5/8" diameter Spring Washer
66	524X.110	Pin for Link, Rack End
67	173/04L	1/4" B.S.F. Locknut
68	182/0416	1/4" B.S.F. Socket Set Screw, Taper Point 1" long
69	155/0620	3/8" B.S.F. Socket Head Cap Screw 1.1/4" long
70	154/06	3/8" diameter Spring Washer
71	524Y.111	Upper Rack, Outer.
72	523X.123	Pinion Shaft
73	523X.121	Outer Pinion
74	524Y.112	Lower Rack, Outer

MAIN CAMSHAFT - DRAWING NO. 544 Z 1A

<u>INDEX</u> <u>NO.</u>	<u>PART</u> <u>NO.</u>	<u>TITLE</u>
1	154/06	3/8" Spring Washer
2	155/0620	3/8" B.S.F. Socket Head Cap Screw 1.1/4" long
3	544Y.102A	End Cover
4	544X.128A	Bearing Clamp Plate
5	544Y.121A	End Bearing Housing
6	263/60	Light Ball Journal, Angular Contact 60 x 110 x 22mm
7	544X.114A	Bearing Extractor
8	125/4080	5/8" Taper Pin 5" long
9	544X.118	Collar
10	544Y.110	Cam Drum Locking, Outer
11	126/1224	1/8" Parallel Pin 1.1/2" long
12	154/08	1/2" Spring Washer
13	155/0820	1/2" B.S.F. Socket Head Cap Screw, 1.1/4" long
14	544Y.107B	Cam, Bar Feed (Short)
15	544Y.109A	Cam, Collet Operation
16	141/21	5/8" Tapped Taper Pin, 3" long
17	154/12	3/4" Spring Washer
18	155/232	3/4" B.S.F. Socket Cap Screw, 2" long
19	544X.139	Roller Pin
20	210/2525	Indicator Washer
21	212/18	1/8" B.S.P. Grease Nipple
22	194/1	1/8" B.S.P. Plug
23	523X.104	Roller for Centre Quadrant
24	176.0406	1/8" B.S.F. Socket Grub Screw, Cup Point 3/8" long
25	544X.133	Key
26	155/0514	5/16" B.S.F. Socket Head Cap Screw, 7/8" long
27	154/05	5/16" Spring Washer
28	544X.134A	Camshaft Bush
29	76.0406	1/4" B.S.F. Socket Comb. Screw, Cup Point 1/4" long
30	235/7928	Oil Seal, Weston, 4.1/2" x 5.3/4" 3/8"
31	125/2236	11/32" Taper Pin 2.1/4" long
32	544Y.124	Geneva Arm
33	544Y.137A	Camshaft Bearing Sleeve
34	544Z.105	Cam, Front Cross Slide
35	544X.112A	Cam Insert Blank
36	155/0620	1/4" B.S.F. Socket Head Cap Screw 1.1/4" long
37	154.06	3/8" B.S.F. Spring Washer
38	544Z.104	Cam, Rear Cross Slide
39	544X.112A	Cam, Insert Blank
40	155/0620	3/4" B.S.F. Socket Head Cap Screw, 1.1/4" long
41	154/06	3/4" B.S.F. Spring Washer
42	544X.136	Camshaft Spacer
43	544Y.103	Cam Disc
44	544Y.138	Camshaft Bearing Sleeve
45	544X.135	Camshaft Bush
46	544X.119	Clutch Plunger
47	544X.129	Clutch Spring
48	544Y.123B	Dog Clutch
49	125/4036	5/8" Taper Pin 2.1/4" long
50	544X.118	Collar
51	176/0406	1/4" B.S.F. Socket Set Screw, Cup Point 3/8" long
52	544Y.122B	Clutch Plate
53	155/1024	5/8" B.S.F. Socket Head Cap Screw 1.1/2" long

MAIN CAMSHAFT - DRAWING NO. 544 Z 1A

<u>INDEX</u> <u>NO.</u>	<u>PART</u> <u>NO.</u>	<u>TITLE</u>
54	154/10	5/8" Spring Washer
55	544X.149	Dowel for 544Y.122A
56	178/0836	1/2" B.S.F. Socket Set Screw, Half-Dog, 2.1/4" long
57	173/08L	1/2" B.S.F. Locknut
58	125/4080	5/8" Taper Pin 5" long
59	544Y.108B	Cam, Collet Operation (Short)
60	44Y.117B	Cam, Collet Operation
61	154/08	1/2" B.S.F. Spring Washer
62	5/0820	1/2" B.S.F. Socket Head Cap Screw 1.1/4" long
63	156/208	2 B.A. Socket Head Cap Screw, 1/2" long
64	544Z.102	Cam Drum
65	544X.142	Filling Piece for Camshaft
66	155/0820	1/2" B.S.F. Socket Head Cap Screw 1.1/4" long
67	154/08	1/2" B.S.F. Spring Washer
68	544Y.106B	Cam. Bar Feed (long)
69	155/0620	3/8" B.S.F. Socket Head Cap Screw 1.1/4" long
70	154/06	3/8" B.S.F. Spring Washer
71	544Y.111	Cam, Drum Locking, Inner
72	544Z.101A	Main Camshaft
73	167/0824	1/2" B.S.F. Hexagon Head Set Screw, 1.1/2" long
74	155/0632	3/8" B.S.F. Socket Head Cap Screw 2" long
75	154/06	3/8" B.S.F. Spring Washer
76	212/18	1/8" B.S.P. Grease Nipple
77	210/2525	Indicator Washer
78	212/04	1/4" B.S.P. Autolub Grease Nipple
79	210/1725	Indicator Washer, Yellow
80	544Y.144	Bar Stop Cam
81	544Y.146	Bar Stop Cam
82	154/06	3/8" B.S.F. Spring Washer
83	155/0614	3/8" B.S.F. Socket Head Cap Screw, 7/8" long
84	544Y.143	Bar Stop "Advance" Cam
85	6/1220	3/8" Parallel Pin, 1.1/4" long
86	155/0616	3/8" B.S.F. Socket Head Cap Screw, 1" long
87	154/06	3/8" B.S.F. Spring Washer
88	125/4080	5/8" Taper Pin 5" long
89	544Z.126	Centre for Bar Stop Cams
90	544Y.145	Bar Stop Cam
91	154/06	3/8" B.S.F. Spring Washer
92	155/0614	3/8" B.S.F. Socket Head Cap Screw, 7/8" long
93	155/0616	3/8" B.S.F. Socket Head Cap Screw, 1" long
94	154/06	3/8" B.S.F. Spring Washer
95	544Y.116	Cam, Bar Stop, Retard
96	126/1220	3/8" Parallel Pin, 1.1/4" long
97	154/06	3/8" Spring Washer
98	126/1220	3/8" Parallel Pin 1.1/4" long
99	155/0616	3/8" B.S.F. Socket Head Cap Screw, 1" long
100	544Y.115A	Cam, Bar Stop Advance
101	544Y.125A	Centre for Bar Stop Cams
102	544Y.116A	Cam, Bar Stop Retard
103	518X.115	End Cap.
104	155/0516	5/16" B.S.F. Socket Head Cap Screw, 1" long
105	154/05	5/16" Spring Washer
106	518X.123	Thrust Plate
107	518X.121	Worm Wheel Bearing

MAIN CAMSHAFT - DRAWING NO. 544 Z 1A

<u>INDEX</u> <u>NO.</u>	<u>PART</u> <u>NO.</u>	<u>TITLE</u>
108	155/1028	5/8" B.S.F. Socket Head Cap Screw, 1.3/4" long
109	154/10	5/8" B.S.F. Spring Washer
110	518Y.124	Worm Wheel
111	518Y.118	Worm Wheel Hub
112	544Y.130A	Cam Drum
113	544X.133	Key
114	155/0514	5/16" B.S.F. Socket Head Cap Screw 7/8" long
115	154/05	5/16" Spring Washer
116	544X.141	Adjusting Washer
117	544X.132A	Camshaft Bearing

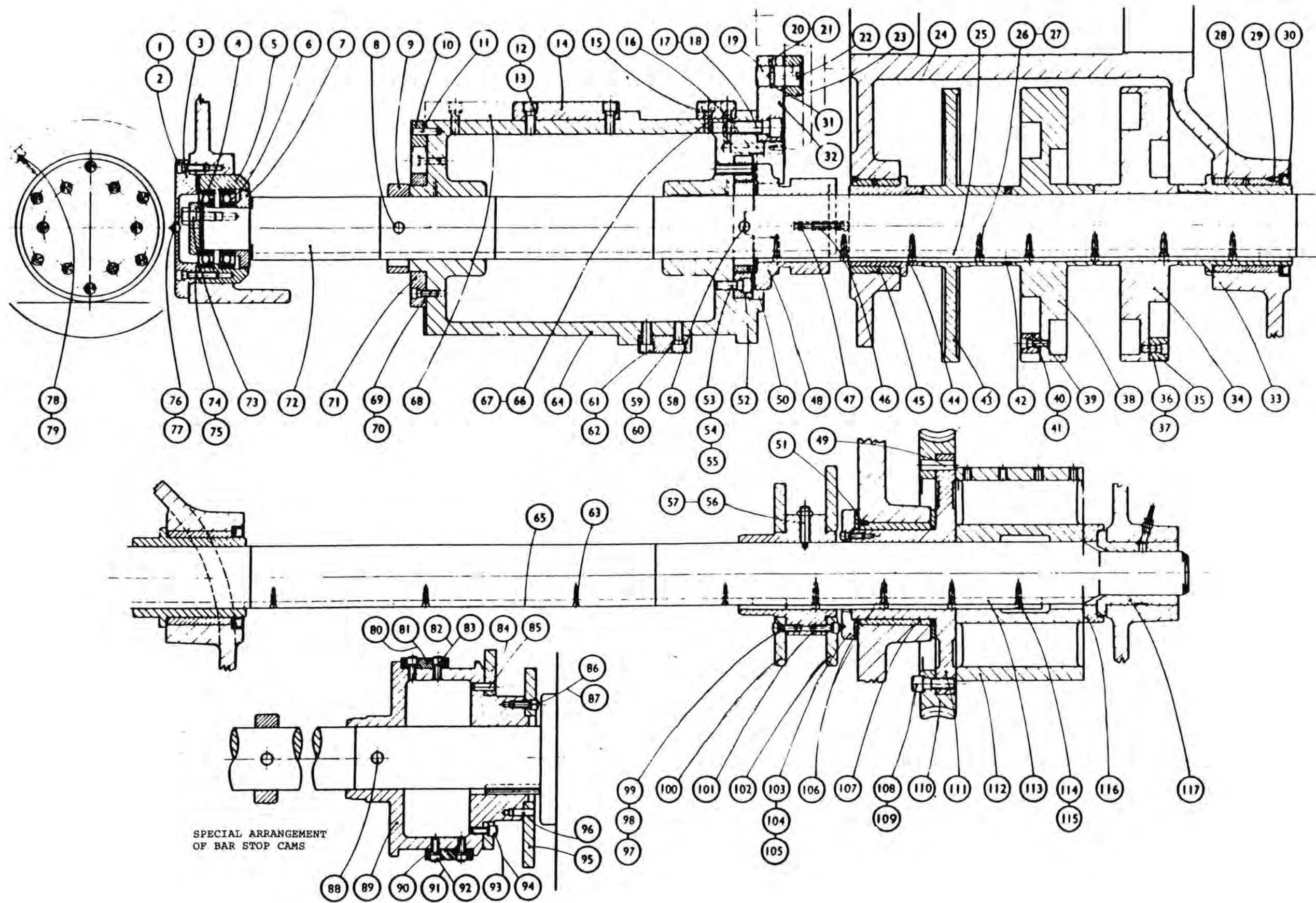

544Z1A

D

MOTOR DRIVE - DRAWING NO. 516 Z 1X

<u>INDEX NO.</u>	<u>PART NO.</u>	<u>TITLE</u>
1	176/1016	5/8" B.S.F. Hexagon Socket Set Screw, Cup Point 1" long
2	522Y.121A	Belt Guard Backplate
3	130/05	5/16" Washer
4	170/0532	5/16" B.S.F. Hexagon Head Bolt 2" long
5	522/Y.122A	Belt Guard
6	167/0614	3/8" B.S.F. Hexagon Head Set Screw 7/8" long
7	130/06	3/8" Washer
8	174/2	2 B.A. Hexagon Nut
9	165/206	2 B.A. Round Head Set Screw 3/8" long
10	572X.110	Instruction Plate, Belt Pulley Director
11	516X.106	Oil Seal Ring
12	235/64806	Weston 50040050 or Superfed 5004
13	516Y.102A	Driving Pulley
14	-	Fenner Belt C. 7/8" x 17/32" x 85" long
15	176/0612	3/8" B.S.F. Hexagon Socket Set Screw, Cup Point 3/4" long
16	517Y.102	Pulley Bearing Cap
17	517Y.101	Driven Pulley Bearing Extension
18	517Y/122A	Pulley Shaft
19	257/165	Medium Ball Journal, 65 x 140 x 33mm
20	517X.183A	Key
21	--	30 H.P. Brooks Motor
22	--	40 H.P. Brooks Motor
23	516X.105	Shaft for Motor Platform
24	154/08	1/2" Lockwasher
25	155/0840	1/2" B.S.F. Socket Head Cap Screw, 2.1/2" long
26	516X.104	Bracket for Motor Platform
27	154/08	1/2" Lockwasher
28	155/0856	1/2" B.S.F. Socket Head Cap Screw, 3.1/2" long
29	167/0614	3/8" B.S.F. Hexagon Head Set Screw, 7/8" long
30	130/06	3/8" Washer
31	516Y.101	Motor Pulley
32	121/2064	Key, 5/8" square, 4" long
33	516X.108	Platform steady Bracket
34	167/12128	3/4" B.S.F. Hexagon Head Set Screw, 8" long
35	167/1248	3/4" B.S.F. Hexagon Head Set Screw, 3" long
36	130/12	3/4" Washer
37	173/12L	3/4" Hexagon Locknut
38	170/0824	1/2" B.S.F. Hexagon Head Bolt, 1.1/2" long
39	130/08	1/2" Washer
40	516Y.103	Motor Platform

**Refer to drawing
showing all part
numbers**

PLAN OF REAR SECTIONS - DRAWING NO. 522-Z 4

<u>INDEX NO.</u>	<u>PART NO.</u>	<u>TITLE</u>
1	522Y.123	Front Tie Rod
2	139/29	Headed Extractable Taper Dowel 4.3/8" long
3	522X.125	Rear Tie Rod
4	139/29	Headed Extractable Taper Dowel 4.3/8" long
5	522Y.133	Pinion Cover
6	155/0616	3/8" B.S.F. Socket Head Cap Screw, 1" long
7	522Z.102	Stock Carriage Indexing Bracket
8	522Z.103	Indexing Gear Bracket
9	522X.124	Clamp Plate
10	155/0824	1/2" B.S.F. Socket Head Cap Screw, 1.1/2" long
11	154/08	1/2" Spring Steel Washer
12	522Z.101	Drum Housing

**Refer to drawing
showing all part
numbers**

DRUM LOCKING OPERATION
SECTION 561
DRG. No. 561Z1

DRUM INDEXING GEAR
2 1/2"-G - SECT 546 - 546Z1, 2 1/2"-GD - SECT 549 - 549Z1
3 1/2"-4 & 1 1/2"-B D. - SECTION 547 - 547Z1
1 1/4"-B, SEC 548, 548Z1

522
Z
102

W.S.P.
15.5/0610
2 B.S.F.
1 LG

522
Y
133

W.S.P.
30/20
1/2 DIA. x 1/2
TAPER
PIN

522
X
125A

CANSHAFT
SECTION 544
DRG. No. 544Z1

522
Z
103

DRUM LOCKING
SECTION 561
DRG. No. 561Z1

BAR FEED
SECTION 558
2 1/2"-G & 2 1/2"-GD
1 1/2"-B & 1 1/2"-B D. 558Z1 3 1/2"-4 - 558Z2

522
X
124

W.S.P.
15.5/0624
2 B.S.F.
x 1 1/2

W.S.P.
54/06
1/2 DIA.
SPRING
WASHER

W.S.P.
30/20
1/2 x 1/2
TAPER
PIN

522
Y
123A

COLLET OPERATION
2 1/2"-G & 1 1/2"-B - SECT 556 - 556Z1
3 1/2"-4 - SECT 557 - 557Z1
2 1/2"-GD & 1 1/4"-B D. - SEC 556A - 556AZ1

INDEX CLUTCH OPERATION
SECTION 545
DRG. No. 545Z1

522
Z
101

M.I.D. & Co. 1752
RENDER ALL DIMENSIONS
UNLESS OTHERWISE STATED
TOLERANCES ON
MACHINING DIMENSIONS
- GO. DIMS.
- HYDRAULIC STAFF

AMERICAN
PRODUCTION
- BRITISH DIMS.
- FINEST MACHINING
- GRINDING
- GRINDING
- MAKE PER - 54
- 54

PUMP MOUNTING UNIT AND FLUSH BLOCK - DRAWING NO. 568 Z 1A

<u>INDEX</u> <u>NO.</u>	<u>PART</u> <u>NO.</u>	<u>TITLE</u>
1	154/0523	5/16" Spring Washer
2	155/0628	3/8" B.S.F. Socket Head Cap Screw, 1.3/4" long
3	150/14	7/8" x 22 T.P.I. Slotted Locknut
4	179/204	2 B.A. Socket Set Screw, Cup Point 1/4" long
5	153/42	Copper Pad
6	568X.133A	Lubricating Pump Driven Sprocket
7	568X.188	Pump Bracket
8	568X.189	Adjusting Collar
9	568X.181	Flanged Pin
10	154/05	5/16" Spring Washer
11	155/0520	" B.S.F. Socket Head Cap Screw, 1.1/4" long
12	154/05	5/16" Spring Washer
13	155/0548	5/16" B.S.F. Socket Head Cap Screw, 3" long
14	221/8	3/8" Tubing Sleeve
15	215/10	3/8" Tubing Nut
16	219/7	3/8" B.S.P., 3/8" Tube, Elbow
17	--	Weston W.03707 Synthetic Rubber Ring
18	--	Enots Y/233 Locknut
19	--	Enots Y.232 Adjusting Screw
20	--	Enots Y.235 Spring
21	--	Enots Y.234 Plunger
22	221/8	3/8" Tubing Sleeve
23	215/10	3/8" Tubing Nut
24	194/3	3/8" B.S.P. Socket Pipe Plug
25	FX.6618	Flush Spring
26	568X.190	Flush Block Valve
27	154/02	3/16" Spring Washer
28	156/208	2 B.A. Socket Head Cap Screw, 1/2" long
29	568X.192	Retaining Plate
30	143/0410	Grooved Pin
31	568X.191	Flush Push Button
32	568X.183	Flush Block

**Refer to drawing
showing all part
numbers**

FIRST USED ON BATCH
872.
LAST USED ON BATCH.

SUPERSEDES
56871.
SUPERSEDED BY.

ALTERATIONS:

FIRST USED ON BATCH
872.
LAST USED ON BATCH.

SUPERSEDES

SUPERSEDED BY

ALTERATIONS:

A- 200A457 FG
B 200A457 FG
23-6-77

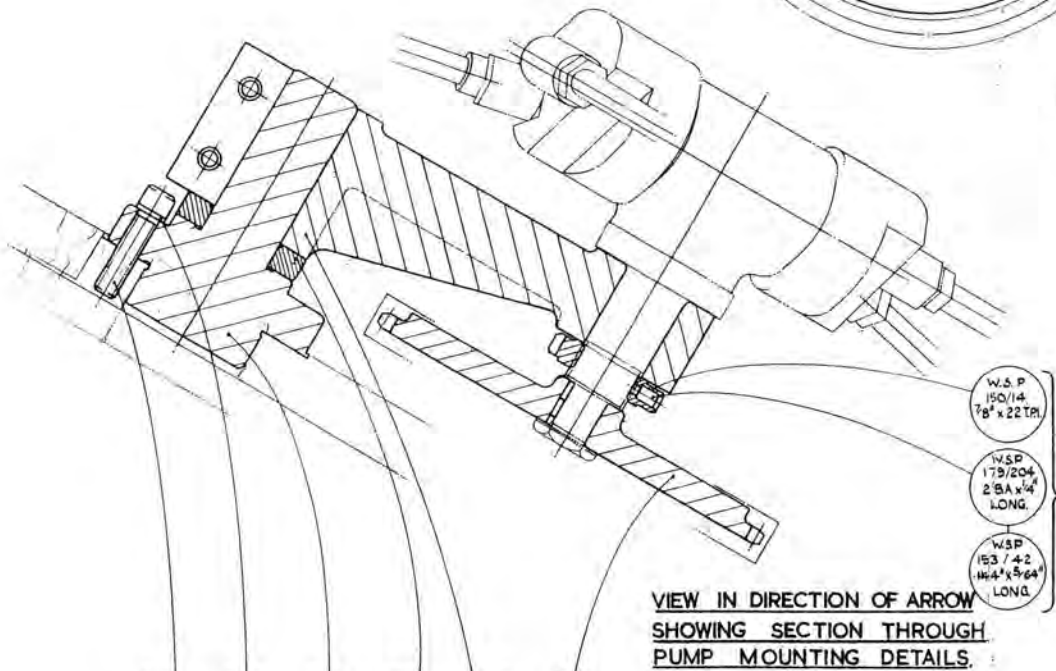
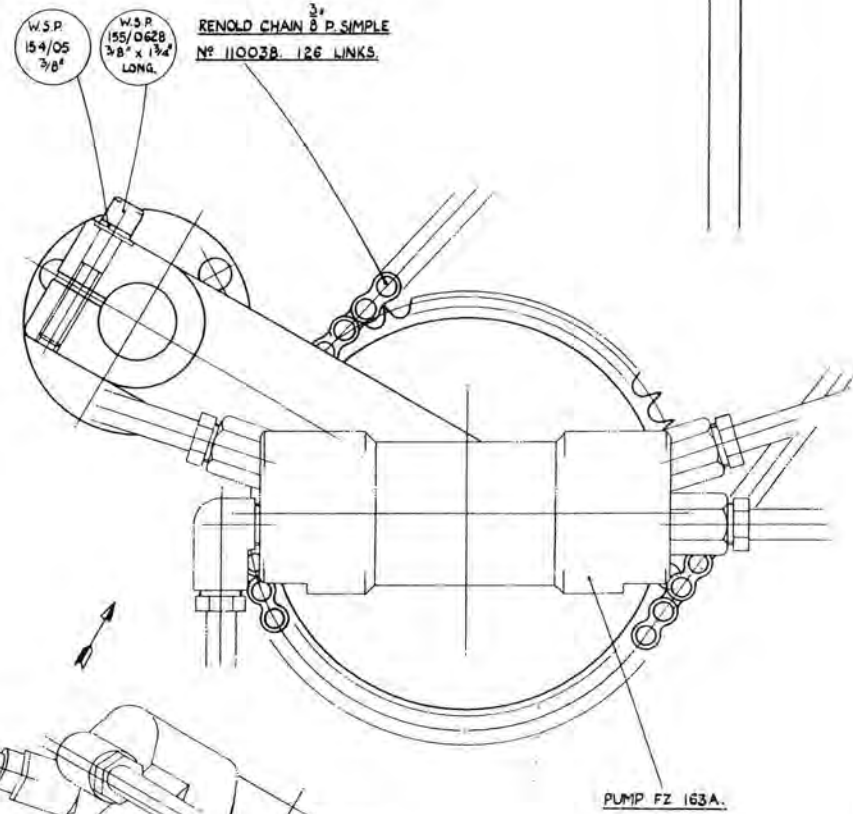

- W.S.P. 155/0520 3/16" x 1 1/4" LONG
- W.S.P. 154/05 3/16"
- 568 x 181.
- 568 x 189
- 568 x 188.
- 568 x 133A.

ADJUST TO
GIVE CORRECT
CHAIN ALIGNMENT.

FOR PIPE & PIPE FITTING REFERENCES
SEE LUBRICATION DIAGRAM 568Z 2B.

SEE ALSO 568 Z 2B, 3B, 4B & 5A.

PUMP-MOUNTING UNIT.

MATERIAL LISTS
568L 1, 2.

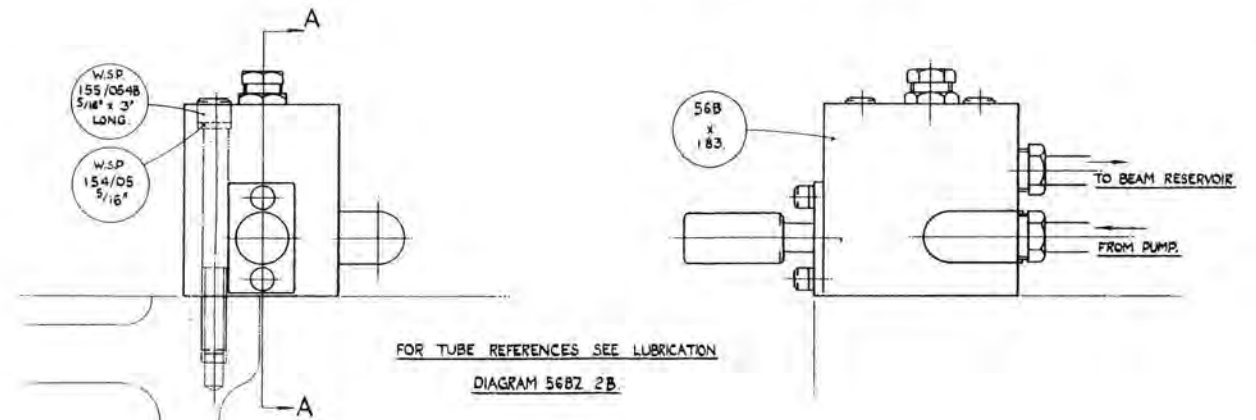
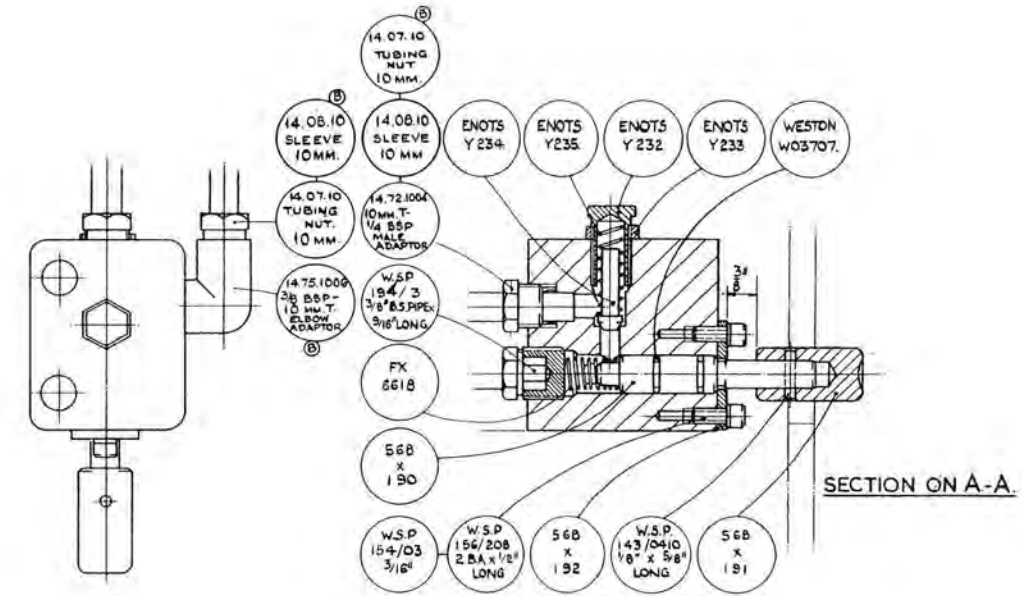

SEE ALSO 568Z 2B, 3B, 4B, & 5A.

FLUSH BLOCK.

MATERIAL LISTS
568L 3, 4.

SPINDLES - DRAWING NO. 511 Z 1A

<u>INDEX</u> <u>NO.</u>	<u>PART</u> <u>NO.</u>	<u>TITLE</u>
1	154/05	5/16" Spring Washer
2	155/0508	5/16" B.S.F. Socket Head Cap Screw, 1/2" long
3	130/05	5/16" Washer
4	511X.140	Cover Plate
5	173/05	5/16" B.S.F. Hexagon Nut
6	511X.173	Stud
7	173/07L	7/16" B.S.F. Locknut
8	178/0724	7/16" B.S.F. Socket Set Screw, Half-Dog 1.1/2" long
9	511Y.109	Index Gear
10	130/05	5/16" Washer
11	--	3/4" Parallel Hardened Steel Roller
12	173/05	5/16" B.S.F. Hexagon Nut
13	511X.141	Stud
14	517X.209	Key for Spindle Drive Gear
15	511Y.136A	Centre Driving Gear
16	155/0416	1/4" B.S.F. Socket Head Cap Screw, 1" long
17	511X.139A	Centre Bearing End Cap
18	154/04	1/4" Spring Washer
19	SB.11	Special Bearing
20	155/0616	3/8" B.S.F. Socket Head Cap Screw 1" long
21	511V.167A	Centre Bearing Bush
22	154/06	3/8" Spring Washer
23	503X.138	Adjustable Spacer
24	511Z.101A	Spindle Drum
25	501X.146A	Locator Strip
26	155/0514	5/16" B.S.F. Socket Head Cap Screw 7/8" long
27	154/05	5/16" Spring Washer
28	511Y.134	Drum Thrust and Stop Ring
29	155/0628	3/8" B.S.F. Socket Head Cap Screw 1.3/4" long
30	511Y.108A	Centre Guide
31	517Z.207A	Centre Shaft
32	317X.142	Threaded Taper Pin
33	203/08L	1/2" B.S.F. Self-Locknut
34	130.08	1/2" Washer
35	511X.118	Front Bearing Spacer
36	155/0520	5/16" B.S.F. Socket Head Cap Screw 1.1/4" long
37	154/05	5/16" Spring Washer
38	511Y.114A	Binding Cap
39	511X.115	Piston Ring
40	22/0814	Key
41	SB.12	Special Bearing
42	511X.147A	Spindle Nose
43	511X.116A	Ring Housing
44	511X.159A	Spacer
45	511X.170	Bearing Spacer
46	511X.169	Bearing Spacer
47	SB.12	Special Bearing
48	511X.171	Bearing Spacer
49	511X.117A	Bearing Spacer
50	SB.12	Special Bearing
51	511X.119	Spacer
52	153/05	Copper Pad 1/8" long
53	176/0506	5/16" B.S.F. Socket Set Screw Cup Point 3/8" long
54	150/50	3.1/8" Slotted Locknut 22 T.P.I.

SPINDLES - DRAWING NO. 511 Z 1A

<u>INDEX NO.</u>	<u>PART NO.</u>	<u>TITLE</u>	
55	511Z.102	Work Spindle	
56	104/48P	Internal Circlip 130mm	
57	511X.172A	Lubricant Guide Bush	
58	511X.120	Rear Bearing Spacer	
59	511X.123	Rear Bearing Inner Spacer	
60	SB.11	Special Bearing	
61	511X.121	Rear Bearing End Cap	
62	155/0412	1/4" B.S.F. Socket Cap Screw 3/4" long	
63	154/04	1/4" Spring Washer	
64	511Y.112	Work Spindle Gear	
65	155/0724	7/16" B.S.F. Socket Cap Screw 1.1/2" long	
66	154/07	7/16" Spring Washer	
67	511X.163	Spindle Gear Key	
68	511X.168	Gear Spacer	
69	511X.142	Locknut	
70	511X.113	Pressure Plate	
71	511X.104	Toggle	
72	511Y.110	Toggle Carrier	
73	511X.161	Spacing Washer	
74	511Y.111	Toggle Operating Sleeve	
75	501X.125	Spring	
76	501X.129A	Plunger	
77	125/1014	5/32" Taper Pin 7/8" long	
78	511X.130	Support Bush	
79	511X.126A	Adjusting Sleeve) Collet Tube Assembly
80	511X.154	Collet Tube) 511X.153
81	511X.165	Tab Washer	
82	511Y.127	Plunger Housing	
83	511X.122	Collet Compensating Washer	
84	511X.158	Key	
85	122/1248T	Key	
86	154/06	3/8" Spring Washer	
87	511X.150	Retaining Screw	
88	511X.143	Tab Washer	
89	503X.243	Clamp Plate	
90	511X.107	Toggle Roller	
91	511X.106	Toggle Roller Pin	
92	511X.105	Toggle Pin	
93	503X.244	Bolt for Clamp Plate	
94	198/18	5/8" Shakeproof Washer	
95	212/04	1/4" B.S.P. Grease Nipple	
96	283/2.7/8"	Thrust Bearing Light Type 2.7/8" x 4.5/32" x 1"))
97	FX.1096A	Locknut) Feed
98	FX.1068B	Locknut) Tube
99	511X.155	Feed Tube) Assembly
100	511Y.132	S;eeve for Feed Tube) 511X.160) 511V.176
101	511X.131	Bearing Housing)
102	511X.133	Adjusting Washer)
103	153/05	Copper Pad 1/8" long)
104	176/0506	5/16" B.S.F. Socket Set Screw Cup Point))
		3/8" long)
105	511X.135	Locknut)

APPLICABLE TO MACHINES
COMMENCING M/C. NO. 8862

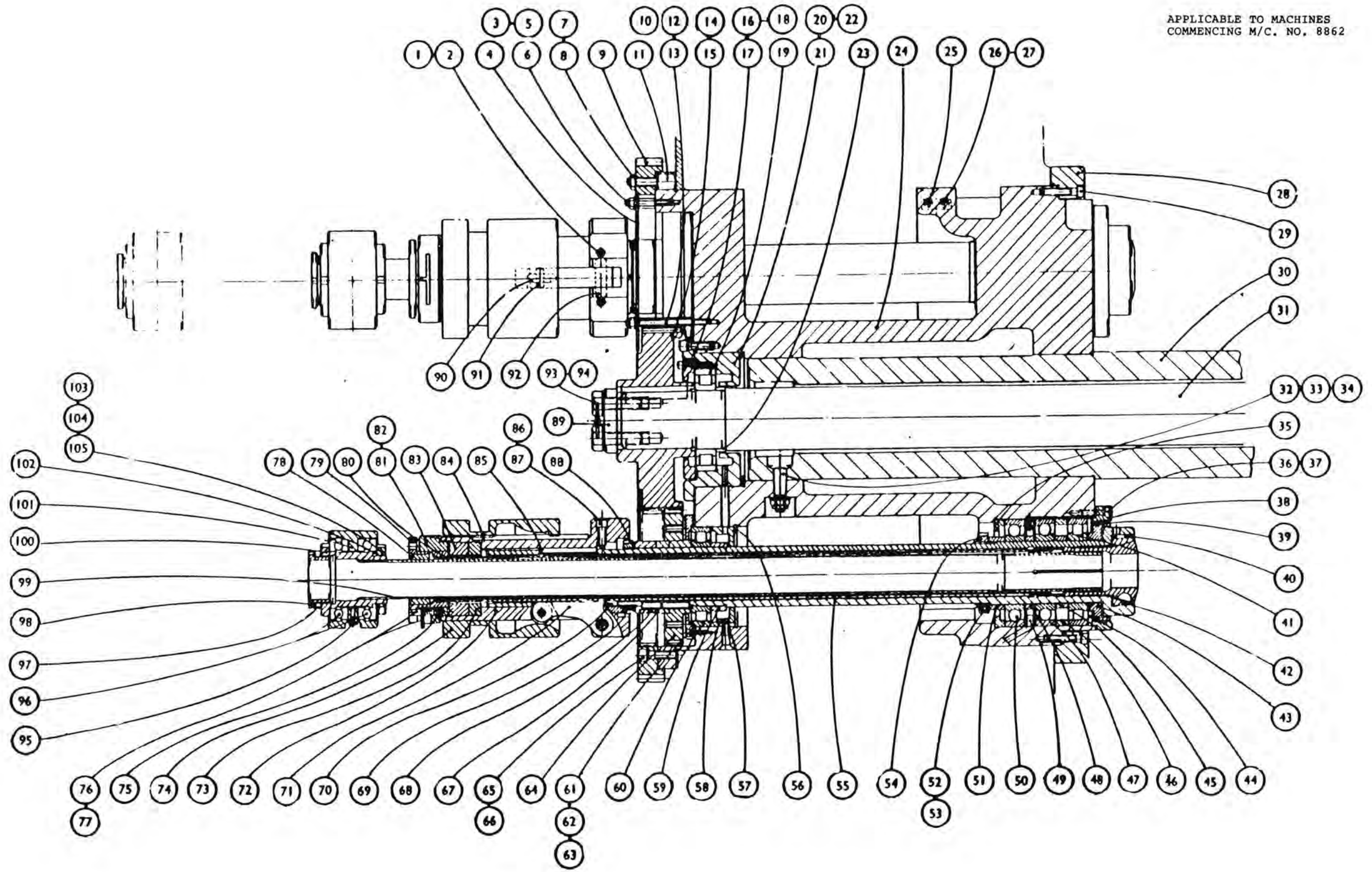

511Z1A

SWARF CONVEYOR - DRAWING NO. 563 Z 1B

<u>INDEX</u> <u>NO.</u>	<u>PART</u> <u>NO.</u>	<u>TITLE</u>
1	182/0412	1/4" B.S.F. Set Screw, Taper Point 3/4" long
2	122/0816	Key 1/4" x 3/16" x 1" long
3	179/206	2 B.A. Hollow Set Screw 3/8" long
4	563X.107C	Drive Coupling
5	563X.127	Spring Ring
6	124/0444	1/8" Steel Pin 2.3/4" long
7	203/05L	5/16" B.S.F. Self-Locking Hexagon Nut
8	130/05	5/16" Washer
9	127/0607	3/32" Split Pin, 7/8" long
10	173/06	3/8" B.S.F. Hexagon Nut
11	235/24346	Superfect Oil Seal 212116
12	236/242820	Oil Retaining Bush 1.1/2" x 1.3/4" x 1.3/4" long
13	563X.143	Pinion
14	182/0408	1/4" B.S.F. Set Screw, Taper Point 1/2" long
15	563X.119	Drive Pin
16	563X.114	Piston Ring
17	236/202420	Oil Retaining Brush 1.1/4" x 1.1/2" x 1.1/4" long
18	129/24	1.3/4" Welch Plug
19	122/1020	Key 5/16" x 7/32" x 1.1/4" long
20	563X.113	Sprocket Shaft
21	563X.111	End Cap
22	156/208	2 B.A. Socket Head Cap Screw 1/2" long
23	154/2	2 B.A. Spring Washer
24	224/3	3/8" B.S.P. Locknut
25	563X.106A	Drive Tube
26	563X.116	Ventilation Pipe
27	563X.145	Driving Bolt
28	563X.126A	Driving Sleeve
29	563X.144	Instruction Plate
30	165/403	4 B.A. Round Head Screw 3/16" long
31	173/04L	1/4" B.S.F. Hexagon Locknut
32	167/0620	5/8" B.S.F. Hexagon Head Set Screw 1.1/4" long
33	154/06	3/8" B.S.F. Spring Washer
34	170/0824	1/2" B.S.F. Hexagon Head Bolt 1.1/2" long
35	63X.107	Support Strip
36	FX.3647	(5 Spindle M/cs)
37	170/0624	3/8" B.S.F. Hexagon Head Bolt 1.1/2" long
38	127/0607	3/32" Split Pin 7/8" long
39	563X.115	Swarf Screw Drive Couple
40	127/0607	3/32" Split Pin 7/8" long
41	173/06	3/8" B.S.F. Hexagon Nut
42	563X.120	Drive Pin
43	156/208	2 B.A. Socket Head Cap Screw 1/2" long
44	154/2	2 B.A. Spring Washer
45	563X.142	Chain Wheel
46	182/0410	1/4" B.S.F. Set Screw, Taper Point 5/8" long
47	563Y.105	Drive Housing Gasket
48	55/0516	5/16" B.S.F. Socket Head Cap Screw 1" long
49	154/05	5/16" Spring Washer
50	--	3/8" Pipe Clip
51	563Y.104	Cover for Drive Housing
52	--	1/2" B.S.P. Hexagon Pipe Plug
53	--	1/2" B.S.P. 90 deg. Elbow M. & F.
54	563X.117	Dust Cap

SWARF CONVEYOR - DRAWING NO. 563 Z 1B

<u>INDEX</u> <u>NO.</u>	<u>PART</u> <u>NO.</u>	<u>TITLE</u>
55	165/206	2 B.A. Round Head screw, 3/8" long
56	236/202420	Oil Retaining Bush 1.1/4" x 1.1/2" x 1/4" long
57	122/1020	Key 5/16" x 7/32" x 1.1/4" long
58	563X.113	Sprocket Shaft
59	236/242820	Oil Retaining Bush 1.1/2" x 1.3/4" x 1.1/4" long
60	63Z.101	Conveyor Drive Housing
61	235/24346	Superfect Oil Seal, 212116
62	154/06	3/8" Spring Washer
63	155/0616	3/8" B.S.F. Socket Head Cap Screw 1" long
64	563X.111	End cap
65	563X.114	Piston Ring
66	173/06	3/8" B.S.F. Hexagon Nut
67	563X.118	Drive Pin
68	563Y.103A	Swarf Screw
69	563Z.102C	Swarf Trough

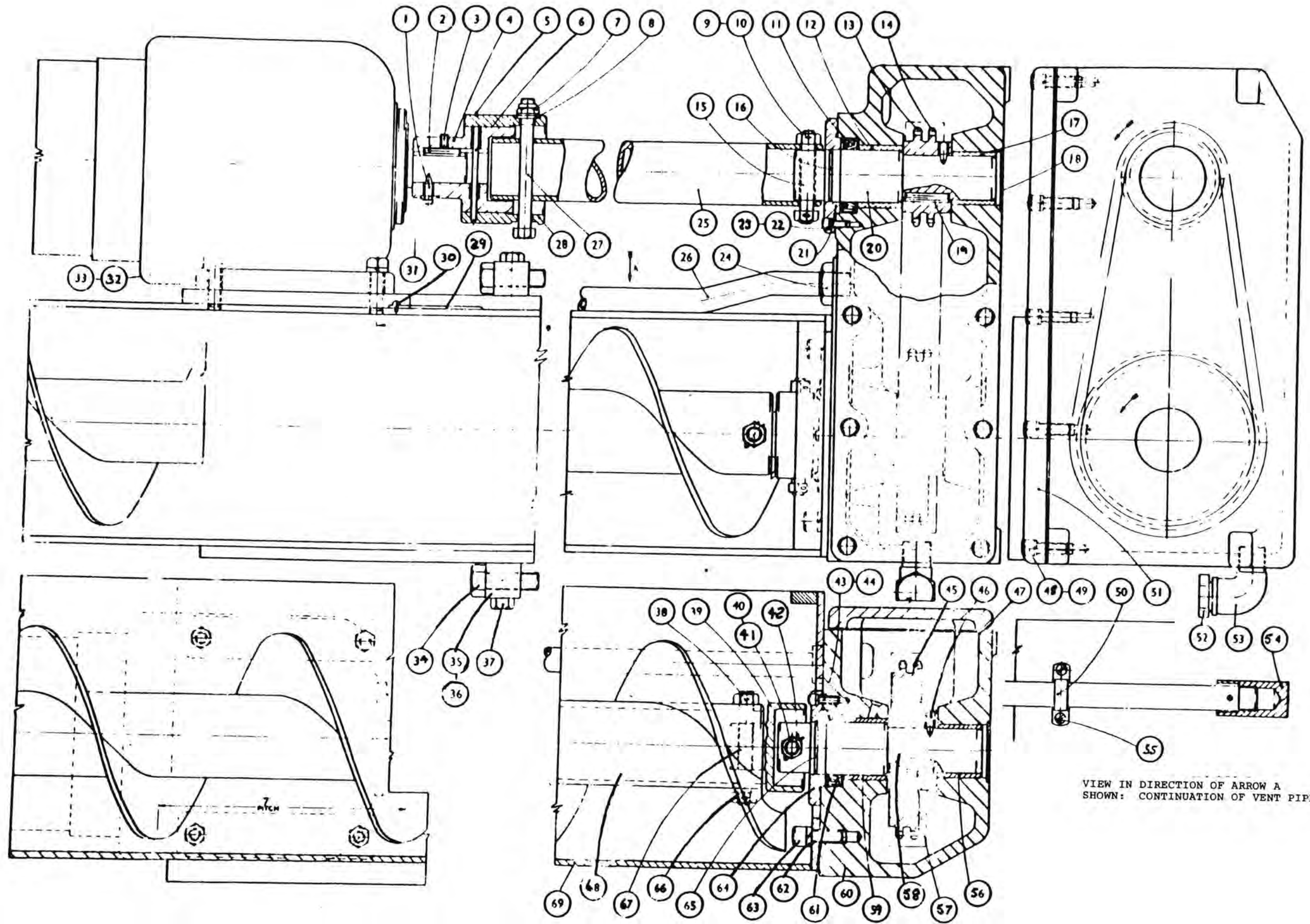

563Z1B

E/G

SWARF CONVEYOR AND SWARF CHUTES - DRAWING NO. 563 Z 2

<u>INDEX</u> <u>NO.</u>	<u>PART</u> <u>NO.</u>	<u>TITLE</u>
1	--	3/8" bore Metal flex.
2	237/0610M	3/8" Metal Flex to 5/8" Male Conduit Adaptor
3	237/82	5/8" Conduit Solid Elbow
4	237/302	5/8" Conduit Nipple
5	237/242	5/8" Conduit Hexagon Locknut
6	237/0612M	3/8" Metal Flex to 3/4" Male Conduit Adaptor
7	237/203	3/4" Conduit Coupler
8	--	Niphan Plug, 5 amp. 500 V.
9	165/208	2 B.A. Round Head Screw 1/2" long
10	--	Niphan Angle Socket No. 465.b
11	FX.7119	Attachment Plate
12	237/0610M	3/8" Metal Flex to 5/8" Male Conduit Adaptor
13	237/242	5/8" Conduit Hexagon Locknut
14	--	3/8" bore Metal Flex
15	237/0612M	3/8" Metal Flex to 3/4" Male Conduit Adaptor
16	237/243	3/4" Conduit Hexagon Locknut
17	165/208	2.B.A. Round Head Screw 1/2" long
18	--	M.E.M. "Startet" Starter 500 volt A.C.
19	563X.137A	Bracket
20	164/0406	1/4" B.S.F. Round Head Screw, 3/8" long
21	563Z.135A	Swarf Chute, Rear (L.H. and R.H.)
22	563Y.133A	Swarf Chute
23	563Z.134A	Swarf Chute, Front (L.H. and R.H.)
24	569X.130	Support Block
25	164/0432	1/2" B.S.F. Round Head Screw 2" long
26	167/0406	1/4" B.S.F. Hexagon Head Set Screw 3/8" long
27	563X.140	Clamp

56372E

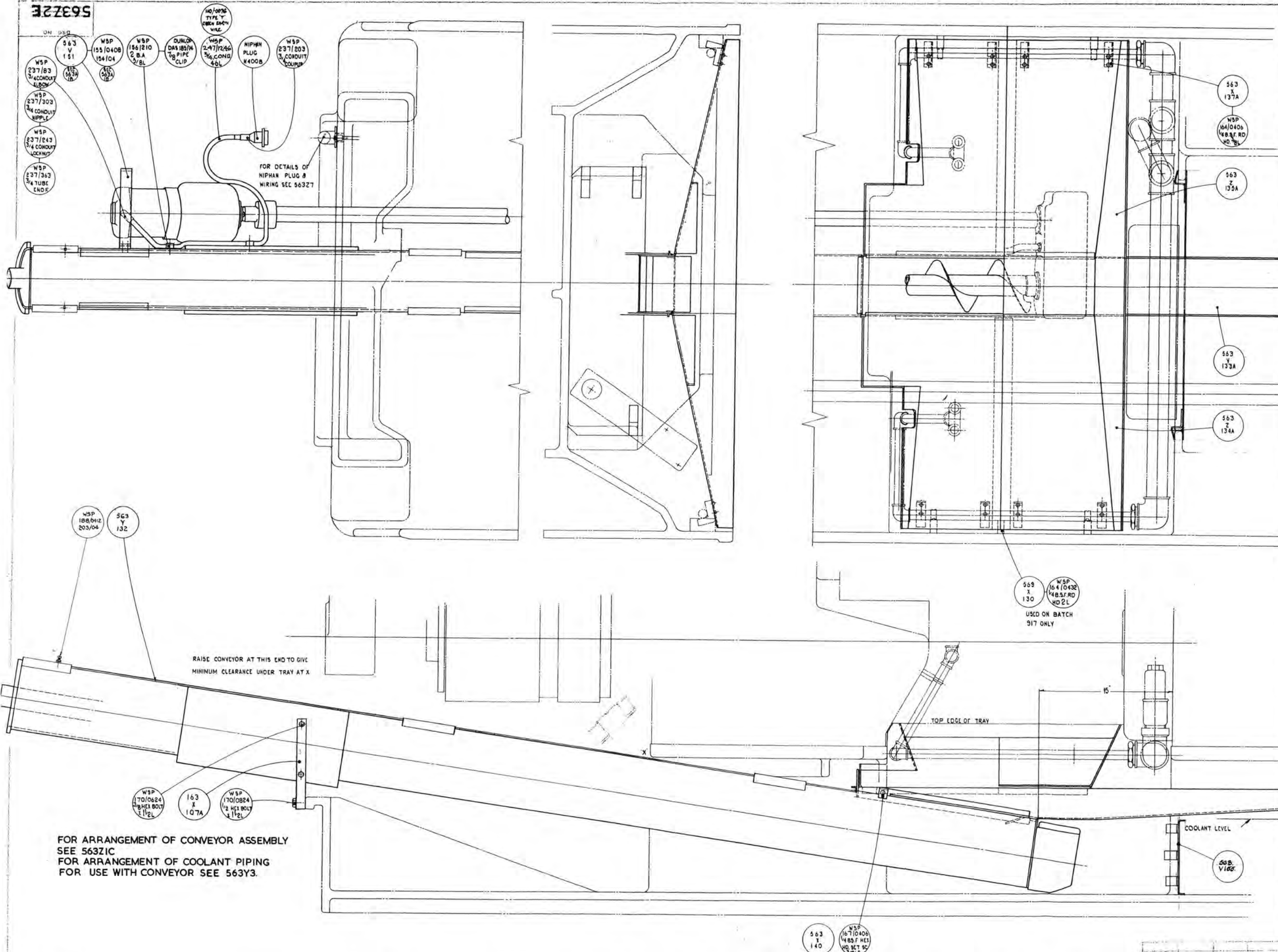

FIRST USED ON BATCH
 LAST USED ON BATCH
 SUPERSEDES
 563Z2D COMMENCING
 W.E. NBR. NO.
 SUPERSEDED BY
 563Z2G
 ALTERATIONS
 CANCELLED
 500A For L.H.
 18-2-60.

FOR ARRANGEMENT OF CONVEYOR ASSEMBLY
 SEE 563Z1C
 FOR ARRANGEMENT OF COOLANT PIPING
 FOR USE WITH CONVEYOR SEE 563Y3.

RAISE CONVEYOR AT THIS END TO GIVE
 MINIMUM CLEARANCE UNDER TRAY AT X

COOLANT LEVEL
 563 V132

REMOVE ALL SHARP
 CORNERS, UNLESS
 OTHERWISE STATED.
 TOLERANCE ON
 MACHINING DIMENSIONS
 ± .010 UNLESS
 OTHERWISE STATED.
 AMERICAN
 PROJECTION.
 R - RALPH MACHINE
 FF - FINISH MACHINE
 FF - GRIND OR
 EQUIVALENT.
 PATTERN/FORGING NO.

563 E 4 M	131-8	MARK 1000-1000
563 E 4 M	298-0	DWG. NO.
563 E 4 M	312-4	

STROKE DIAGRAM FOR REAMING CAMS, STATIONS 3AND 6 - DRAWING NO. 588-Y-2A

<u>INDEX</u> <u>NO.</u>	<u>PART</u> <u>NO.</u>	<u>TITLE</u>
1	155/0814	1/2" B.S.F. socket Head Cap Screw 7/8" long
2	587B.Y.104	Inner Guard Cam
3	588B.Y.108	Reaming Cam 1.7/8" Feed Stroke, Station 6
4	588B.Y.107	Reaming Cam 3.3/4" Feed Stroke, Station 6
5	588B.Y.109	Reaming Cam 5.5/8" Feed Stroke, Station 6
6	588B.Y.105	Guard Cam
7	588B.Y.106	Return Cam, 6th Station Reaming
8	588C.Y.104	Inner Guard Cam, 3rd Station
9	588C.Y.108	Reaming Cam 1.7/8" Feed Stroke, Station 3
10	588C.Y.107	Reaming Cam 3.3/4" Feed Stroke, Station 3
11	155/0814	1/2" B.S.F. Socket Head Cap Screw, 7/8" long
12	588B.Y.105	Guard Cam
13	588C.Y.106	Return Cam, 3rd Station Reaming
14	587A.Y.105	Guard Cam
15	587A.Y.106	Return Cam
16	588A.Y.105	Return Guard Cam 1.7.8" stroke
17	588A.Y.104	Return Guard Cam 3.3/4" stroke
18	155/0814	1/2" B.S.F. Socket Head Cap Screw 7/8" long
19	588A.Y.108	Reaming Cam 1.7/8" stroke
20	588A.Y.107	Reaming Cam 3.3/4" stroke

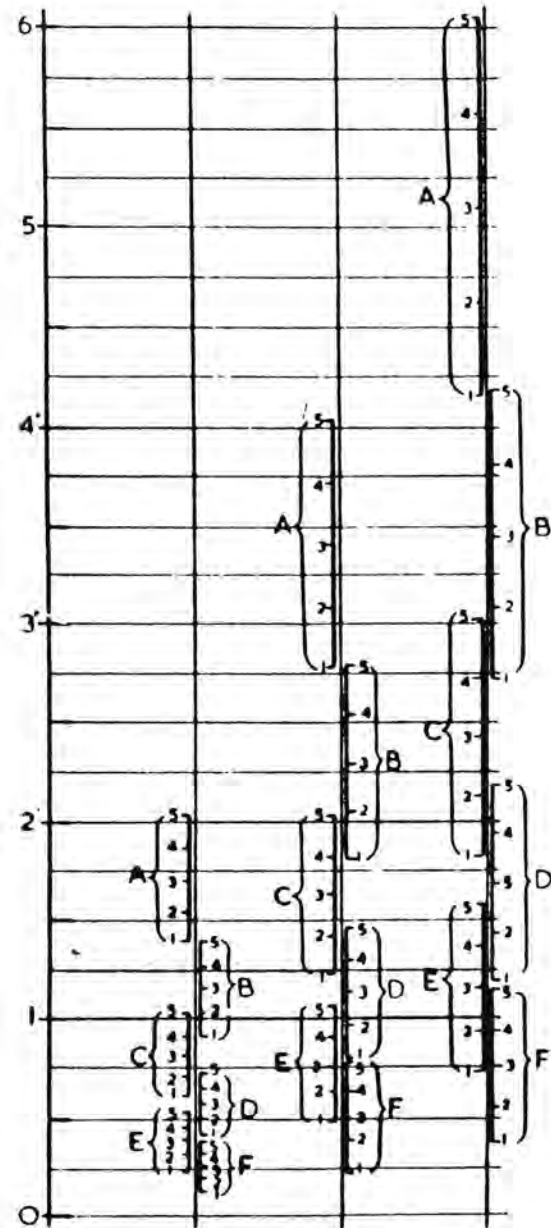

TO READ CHART

- 1 - ON FEED STROKE SCALE ON LEFT MARK THE FEED STROKE REQUIRED
- 2 - DRAW HORIZONTAL - LINE ACROSS TO VERTICAL LINE REPRESENTING CAM FITTED (1.7/8", 3.3/4", 5.5.8") STROKE
- 3 - WHERE THE VERTICAL LINE GIVES THE PIVOT POSITION (AB -ECT) AND THE RELATIVE POSITION OF THE PUSHER CONNECTION WITH THE GRADUATIONS ON THE LOWER END OF THE LEVER (12 ECT)

REAMING

TO OBTAIN FEED PER REV

STANDARD TIMING CAMS (STAT. 3 ONLY)
 FEED PER REF. IS THE SAME AS SHOWN ON SPEED AND FEED CHART FOR THE PARTICULAR STROKE IN USE

ACCELERATED TIMING CAMS (STAT. 3 & 6)
 MULTIPLY ACTUAL STROKE BY TWO AND FIND FEED PER REV. FOR THIS STROKE FROM SPEED AND FEED CHART

THREADING USING REAMING CAMS (DIEHEAD OR COLLAPSING TAPS ONLY)
 TO OBTAIN STROKE REQUIRED

STANDARD TIMING CAM (STAT. 3 ONLY)
 STROKE REQUIRED = $\frac{\text{AVAILABLE CUTTING REV.}}{\text{TP: - THREADING ON RATIO}}$

ACCELERATED TIMING CAM (STAT. 3 & 6)
 STROKE REQUIRED = $\frac{\text{AVAILABLE CUTTING REVS.}}{2 \times \text{T.P.I. = THREADING ON RATIO}}$

PUSHER CONNECTION

BRACKET IN UPPER POSITION

BRACKET IN LOWER POSITION

ALTERNATIVE POSITION OF BRACKET

LINES MARKED ON FACES OF CAMS TO BE IN LINE WITH NOTCH IN PERIPHERY OF CAM CARRIER

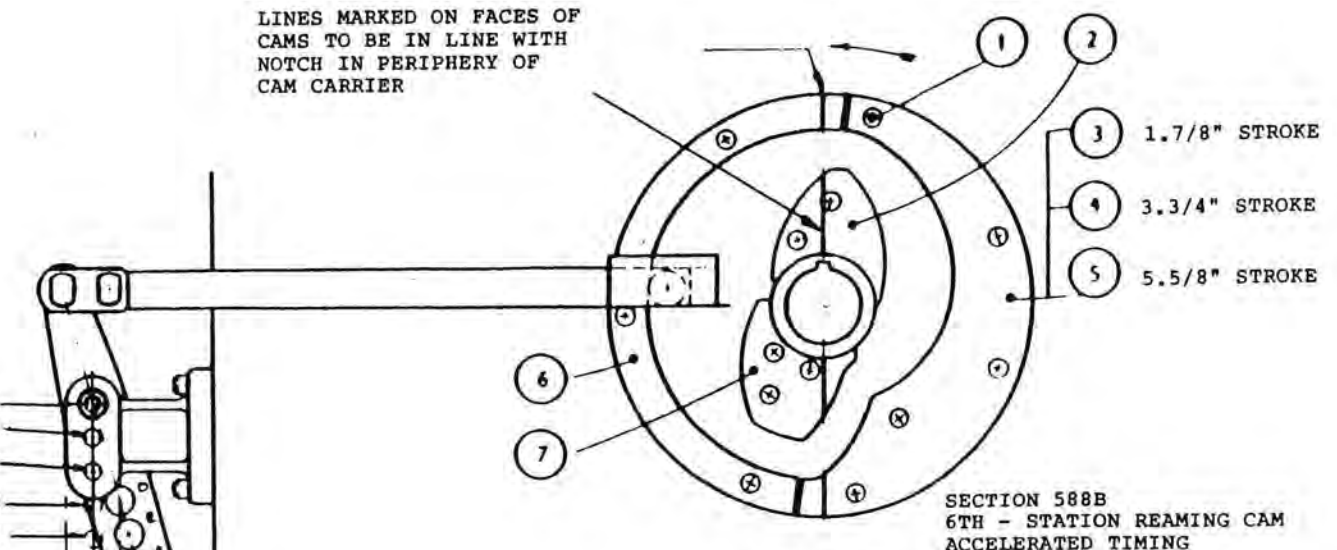

SECTION 588B
 6TH - STATION REAMING CAM
 ACCELERATED TIMING

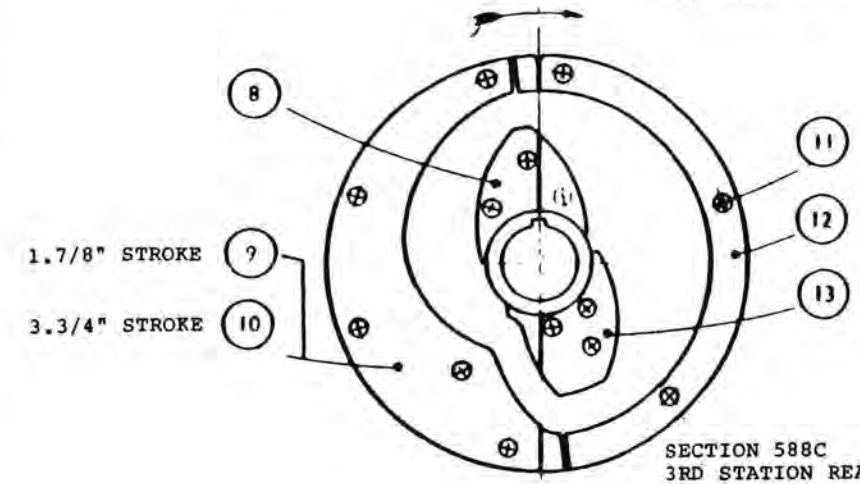

SECTION 588C
 3RD STATION REAMING CAM
 ACCELERATED TIMING

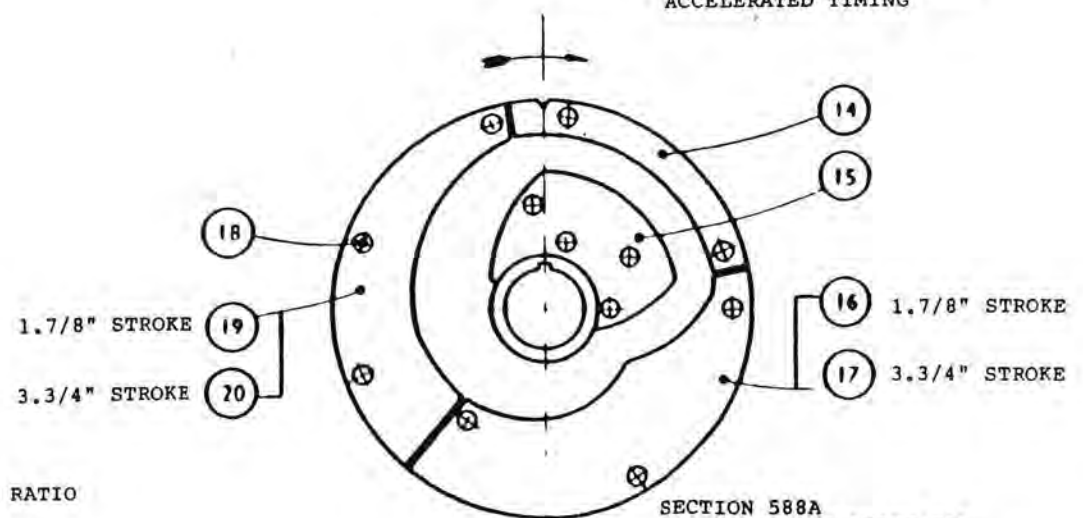

SECTION 588A
 3RD STATION REAMING CAM
 STANDARD TIMING

THREADING CAMS, STATIONS 3 AND 6 - DRAWING NO. 587 Y 3A

<u>INDEX</u> <u>NO.</u>	<u>PART</u> <u>NO.</u>	<u>TITLE</u>
1	155/0814	1/2" B.S.F. socket Head Cap Screw 7/8" long
2	587B.Y.104	Inner Guard Cam
3	587B.Y.108	Threading Cam
4	588B.Y.105	Guard Cam
5	587B.Y.106	Return Cam
6	588C.Y.104	Inner Guard Cam, Station 3
7	587C.Y.108	Threading Cam
8	155/0814	1/2" B.S.F. Socket Head Cap Screw 7/8" long
9	587C.Y.106	Return Cam
10	588B.Y.105	Guard Cam
11	587A.Y.105	Guard Cam
12	587A.Y.106	Return Cam
13	587A.Y.107	Return Guard Cam
14	587A.Y.108	Threading Cam
15	155/0814	1/2" B.S.F. Socket Head Cap Screw 7/8" long
16	87A.Y.103	Drop Back Cam

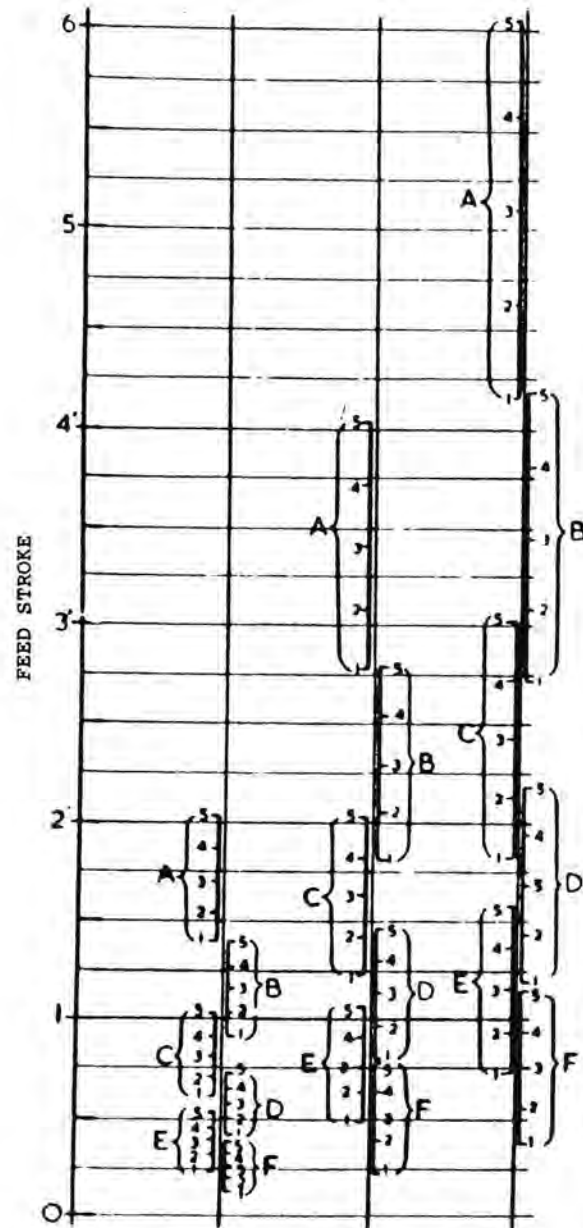

TO OBTAIN STROKE REQUIRED:-
 USE THE FOLLOWING FORMULAE TO OBTAIN STROKE REQ. WITH 3RD & 6TH POS. THREADING CAMS

$$\text{STROKE REQUIRED} = \frac{\text{AVAILABLE CUTTING REVS.}}{4 \times \text{T.P.I.} \times \text{THREADING RATION 'ON'}}$$

TO FIND STROKE SETTING:

- 1: ON FEED STROKE SCALE ON LEFT MARK FEED STROKE REQUIRED (CALCULATED AS ABOVE)
- 2: DRAW A HORIZONTAL LINE ACROSS TO BRACKETED COLUMN
- 3: WHERE THE HORIZONTAL LINE CUTS THE BRACKETS GIVES THE PIVOT POSITION (A,B, ECT) C THE RELATIVE POSITION OF THE PUSHER CONNECTION WITH THE GRADUATIONS ON THE LOWER END OF THE LEVER (1, 2, ECT)

APPROACH STROKE = 375 x FEED STROKE

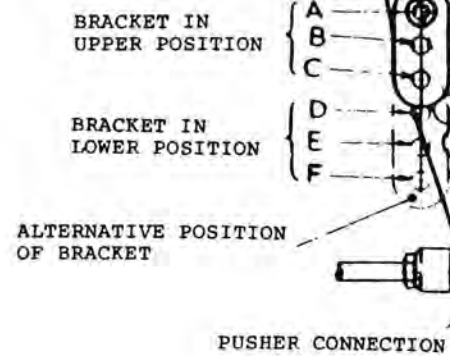

LINES MARKED ON FACES OF CAMS TO BE IN LINE WITH NOTCH IN PERIPHERY OF CAM CARRIER

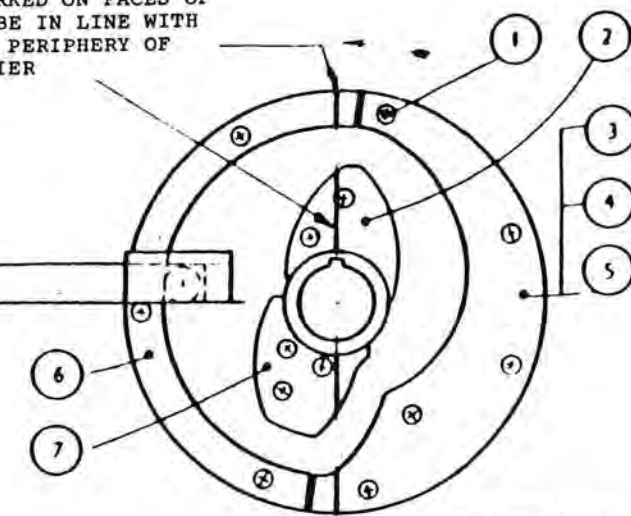

SECTION 587B
 6TH POSITION THREADING CAM
 ACCELERATED TIMING

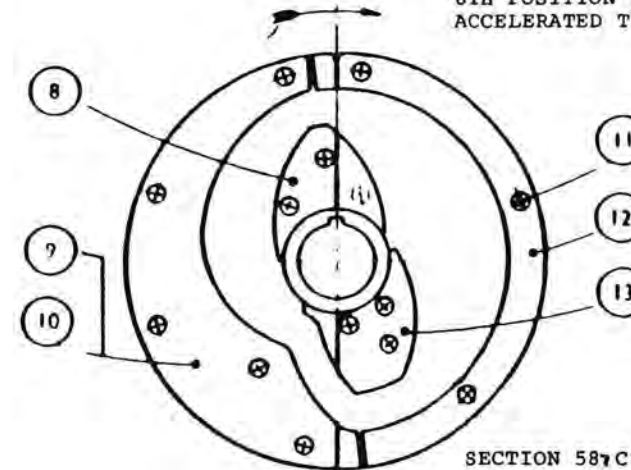

SECTION 587C
 3RD STATION REAMING CAM
 ACCELERATED TIMING

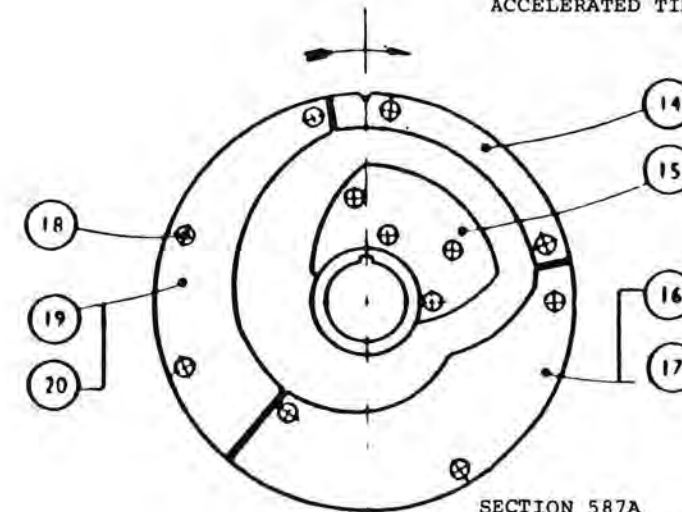

SECTION 587A
 3RD POSITION THREADING CAM
 STANDARD TIMING

MAIN DRIVE GEARING - DRAWING NO. 517 Z 3

<u>INDEX</u> <u>NO.</u>	<u>PART</u> <u>NO.</u>	<u>TITLE</u>
1	503Y 0	Centre Guide
2	176/05 6	5/8" B.S.F. Socket Head Set Screw, Cup Point 3/8" long
3	153/05	Copper Pad 3/8" long
4	151/85	85mm Slotted Locknut
5	194/1	5/8" B.S.P. Socket Pipe Plug
6	22/1 80T	Key Tapped
7	517X.212	Attachment Drive Gear, 36T (2.5/8"-6 and 3.1/4"-6 Spindle)
	517X.210	Attachment Drive Gear, 34T, (3.1/2"-4 and 4.1/8"-4 Spindle)
8	517X.213	Attachment Drive Gear, 50T (2.5/8"-6 and 3.1/4"-6 Spindle)
	517X.1 1A	Attachment Drive Gear, 46T, (3.1/2"-4 and 4.1/8"-4 Spindle)
9	517X.214	Adjustable Spacer
10	517Z.207A	Centre Shaft
11	150/22	1.3/8 Slotted Locknut
12	153/04	Copper Pad 3/32" long
13	176/0405	B.S.F. Socket Set Screw Cup Point 3/16" long
14	155/0520	5/16" B.S.F. Socket Head Cap Screw 1.1/4" long (2.5/8"-6 and 3.1/4"-6)
15	517X.107A	Cap
16	183/0520	5/16" B.S.F. Square Head set Screw Taper Point 1.1/4" long
17	203/05	5/16" B.S.F. Self Locking Hexagon Nut
18	258/70	Ball Journal, Medium Type 70 x 125 x 24mm (2.5/8"-6 and 3.1/4"-6)
19	517V.111B	Jackshaft Jockey Carrier (2.5/8"-6 and 3.1/4"-6)
20	518X.162A	Jockey Pin
21	517Y.141	Jackshaft Drive Sprocket 31T (2.5/8"-6 and 3.1/4"-6)
	517V.142A	Jackshaft Drive Sprocket 24T (2.5/8"-6 and 3.1/4"-6)
22	517X.129	Collar (2.5/8"-6 and 3.1/4"-6)
23	122/1648T	Ley, Tapped
24	151/170	70mm Slotted Locknut
25	153/05	Copper Pad 1/4" long
26	176/0506	5/16" B.S.F. Socket Head Cap Screw, Cup Point 3/8" long
27	517Y.148	Low Range Gear 46T
28	257/55	Ball Journal, Medium Type 55 x 120 x 29mm
29	517X.126	Collar
30	122/0824T	Key, Tapped
31	517X.139	Feed Drive Sprocket 22T
32	155/0616	3/8" B.S.F. Socket Head Cap Screw 1" long
33	--	Speed Pick Off Gears
34	517Y.106	Bearing Housing
35	104/50	140mm Internal Circlip
36	257/65	Ball Journal, Medium Type 65 x 140 x 33mm
37	151/65	65mm Slotted Locknut
38	153/05	Copper Pad, 1/4" long
39	176.0506	5/16" Socket Head Set Screw, Cup Point 3.8" long
40	155/0410	1/4" B.S.F. Socket Head Cap Screw, 3/8" long

MAIN DRIVE GEARING - DRAWING NO. 517 Z 3

<u>INDEX</u> <u>NO.</u>	<u>PART</u> <u>NO.</u>	<u>TITLE</u>
41	517X.185	Key for Slip Gears
42	517X.116	"C" Washer
43	203/16L	1" B.S.F. Self Locking Nut, thin type
44	517Y.105A	Bearing Housing
45	104/48	130mm Internal Circlip
46	151/60	60mm Slotted Locknut
47	153/05	Copper Pad 1/8" long
48	176/0506	5/16" B.S.F. Socket Head Set Screw, Cup Point 3/8" long
49	257/60	Ball Journal Medium Type 60 x 130 x 31mm
50	517Y.125A	Range Gear Shaft
51	517X.185	Key
52	155/0410	1/4" B.S.F. Socket Head Cap Screw, 3/8" long
53	176/0506	5/16" B.S.F. Socket Set Screw, Cup Point 3/8" long
54	150/44	2.3/4" Slotted Locknut
55	153/05	Copper Pad 1/8" long
56	517X.123	Collar
57	155/0520	5/16" B.S.F. Socket Head Cap Screw 1.1/4" long
58	154/05	5/16" Spring Washer
59	257/65	Ball Journal, Medium Type 65 x 140 x 33mm
60	--	Weston Oil Seal, 50040050, 5" x 4" x 1/2"
61	55/0824	1/2" BSF Socket Head Cap Screw 1.1/2" long
62	516X.106	Oil seal Ring
63	150/38	2.5/8" Slotted Locknut
64	153/05	Copper Psd, 1/8" long
65	176/0506	5/16" Socket Set Screw, Cup Point 3/8" long
66	517Y.102	Pulley Bearing Cap
67	517Y.101	Driven Pulley Bearing Extension
68	522X.156	Plug
69	516Y.102A	Driving Pulley
70	517X.133	Pump Drive Sprocket
71	121/0824T	Key, Tapped
72	517X.103	Spacer
73	121/0816T	Key, Tapped
74	517X.134	Oil Pump Drive Sprocket
75	258/75	Ball Journal Medium Type 75 x 130 x 25mm
76	122/1632T	Key, Tapped
77	517Y.135A	Fast Motion Drive Sprocket, (2.5/8"-6 and 1.3/4"-8 spindle)
	517Y.136	Fast Motion Drive Sprocket, (3.1/4"-6, 3.1/2"-4 and 4.1/8"-4 spindle)
78	150/44	2.3/4" Slotted Locknut
79	153/05	Copper Pad 1/8" long
80	176/0506	5/16" B.S.F. Socket Set Screw, Cup Point 3/8" long
81	155/0616	3/8" B.S.F. Socket Head Cap Screw 1" long
82	517X.137	Pulley Shaft Abutment
83	257/60	Ball Journal, Medium Type 60 x 130 x 31mm
84	151/600	60mm Slotted Locknut
85	153/05	Copper Pad 1/8" long
86	176/0506	5/16" B.S.F. Socket Set screw, cup Point 3/4" long
87	7Y.120	Low Range Sliding Pinion
88	22/1626T	Key Tapped
89	519X.115	Glut
90	519X.165	Glut Shaft

MAIN DRIVE GEARING - DRAWING NO. 517 Z 3

<u>INDEX NO.</u>	<u>PART NO.</u>	<u>TITLE</u>
91	177/0612	3/8" B.S.F. Socket Set Screw, Cone Point 3/4" long
92	517Z.122A	Pulley Shaft
93	122/1452T	Key, Tapped
94	517X.143	Bearing Sleeve (3.1/2"-4 and 4.1/8"-4 spindle)
95	182/0616	3/8" B.S.F. Socket Set Screw, Taper Point, 1" long
96	517X.216	Collar
97	517V.208	Centre Guide Bearing
98	155/0724	7/16" B.S.F. Socket Head Cap screw 1.1/2" long
99	258/85	Ball Journal, Medium Type 85 x 150 x 28mm
100	517X.124	Adjustable Spacer
101	257/40	Ball Journal, Medium type 40 x 90 x 23mm
102	122/1652T	Key, Tapped
103	517X.127	Collar
104	522 X.154	Plug
105	517X.124	Collar
106	176/0405	1/4" B.S.F. Socket Set Screw, Cup Point 5/16" long
107	153/04	Copper Pad, 3/32" long
108	150/22	1.3/8" Slotted Locknut
109	517X.104	Bearing Sleeve
110	257/40	Ball Journal, Medium Type 40 x 90 x 23mm
111	517X.130	Collar
112	182/0616	3/8" B.S.F. Socket Set Screw, Taper Point 1" long
113	517Y.146	High Range Sliding Gear
114	511Y.108A	Centre Guide
115	Y.203A	Jackshaft Jockey Carrier)
116	517X.206	Jockey Sprocket)
117	236/121618	Oil Retaining Bush)
118	517X.205	Jockey Pin)
119	125/1024	3/32" Taper Pin, 1.1/2" long)
120	122/1648T	Key, Tapped)
121	517X.195	Collar) 1.3/4"-8
122	151/70	70mm Slotted Locknut) only
123	176/0506	5/16" B.S.F. Socket Set Screw, Cup Point) 3/8" long)
124	153/05	Copper Pad, 1/8" long)
125	517X.204	Jockey Carrier Plate)
126	155/0516	5/16" B.S.F. Socket Head Cap Screw) 1" long)
127	154/05	5/16" Spring Washer)
128	517X.196	Jackshaft Drive Sprocket)
129	258/70	Bail Journal, Medium Type) 70 x 125 x 24mm)
130	517X.107A	Cap)
131	155/0520	5/16" B.S.F. Socket Head Cap Screw) 1.1/4" long)
132	154/05	5/16" Spring Washer)
133	122/1680T	Key, Tapped)
134	517X.197A	Spacer)
135	517X.199A	Attachment Drive Gear)
136	258/85	Ball Journal, Medium Type) 85 x 150 x 28mm)
137	151/85	85mm Slotted Locknut)
138	176/0506	5/16" B.S.F. Socket Set Screw, Cup Point) 3/8" long)
139	153/05	Copper Pad 1/8" only)
140	517V.202A	Bearing Housing)

MAIN DRIVE GEARING - DRAWING NO. 517 Z 3

<u>INDEX</u> <u>NO.</u>	<u>PART</u> <u>NO.</u>	<u>TITLE</u>	
141	155/0524	5/16" B.S.F. Socket Head Cap Screw, 1.1/2" long)
142	154/05	5/16" Spring Washer)
143	517Y.201	Centre Guide Bearing)
144	155/0824	1/2" B.S.F. Socket Head Cap Screw, 1.1/2" long)
145	54/08	1/2" Spring Washer)
146	212/1656T	Key. Tapped)

LIST OF AVAILABLE SPINDLE SPEED				PICK OFF GEARS	
22T	517Y159	37T	517Y165	52T	517Y171
24T	517Y160	40T	517Y166	55T	517Y172
27T	517Y161	42T	517Y167	57T	517Y173
30T	517Y162	45T	517Y168	60T	517Y174
32T	517Y163	47T	517Y169	63T	517Y175
35T	517Y164	50T	517Y170	65T	517Y176

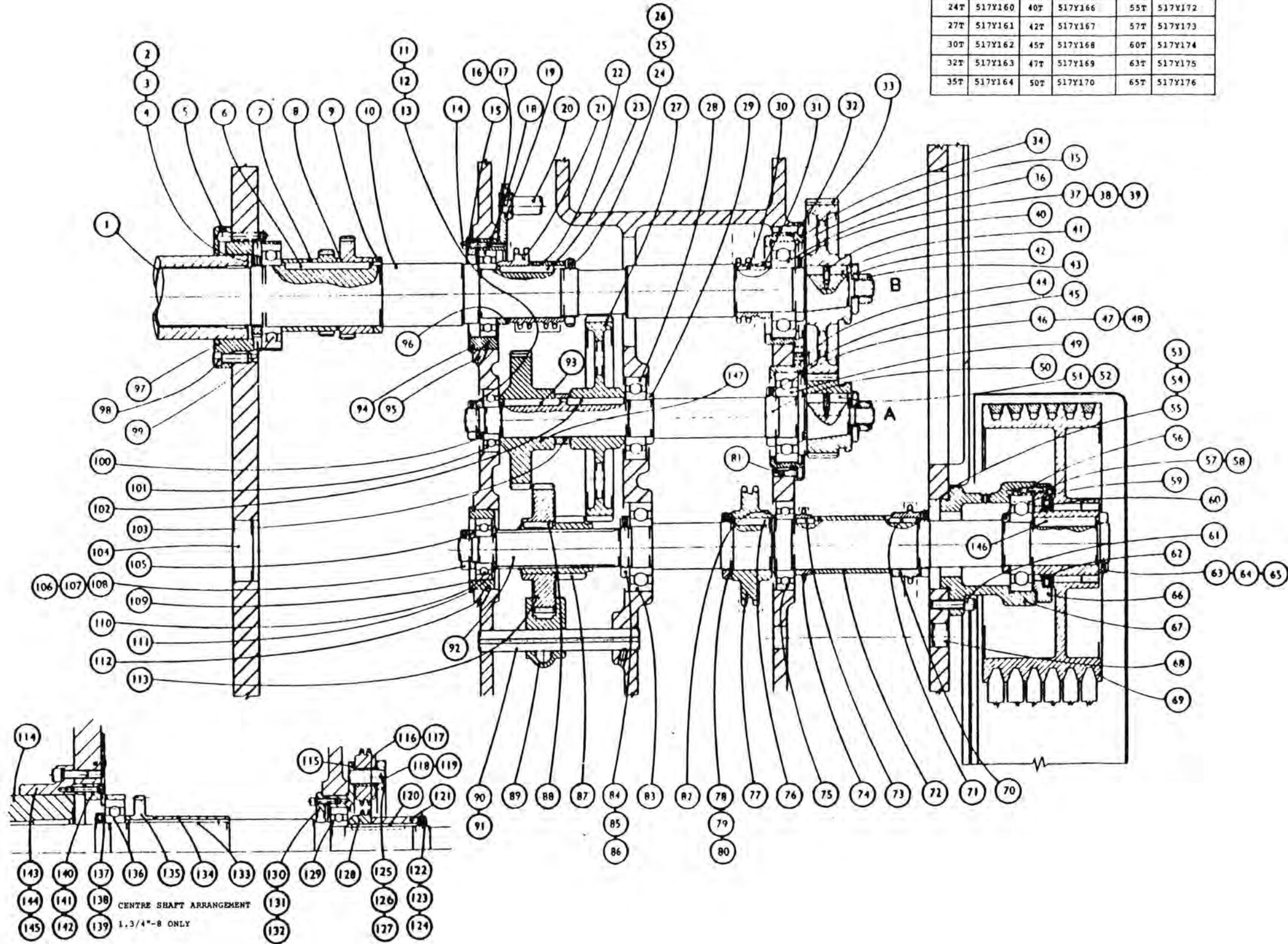

APPLICABLE TO MACHINES
 COMMENCING M/C No's:
 8821 - 2.5/8"-6
 8823 - 3.1/2"-4
 8862 - 1.3/4"-8

- ISSUE NO. 000A104
- JRM 10-3-54
- A 500A189 JRM 11-0-54
- B 500A223 KF 8-11-54
- C 500A254 RS 20-4-55
- D 500A251 RES 2-6-55
- E 500A279 KF 28-12-55
- F 500A257 HJG 11-8-56
- G 500A298 RMC 6-10-56
- H 500A306 RMC 5-11-56
- J 500A254 TH 10-6-56
- K 500A260 LPM 28-8-58
- L 500A362 HJG 16-9-58
- M 500A298 GWF 3-2-60
- N 500A457 LPM 1-6-60
- O 500A458 RS 23-8-60
- P 500A444 MD 28-11-60
- Q 500A 610 KH 11/2/63

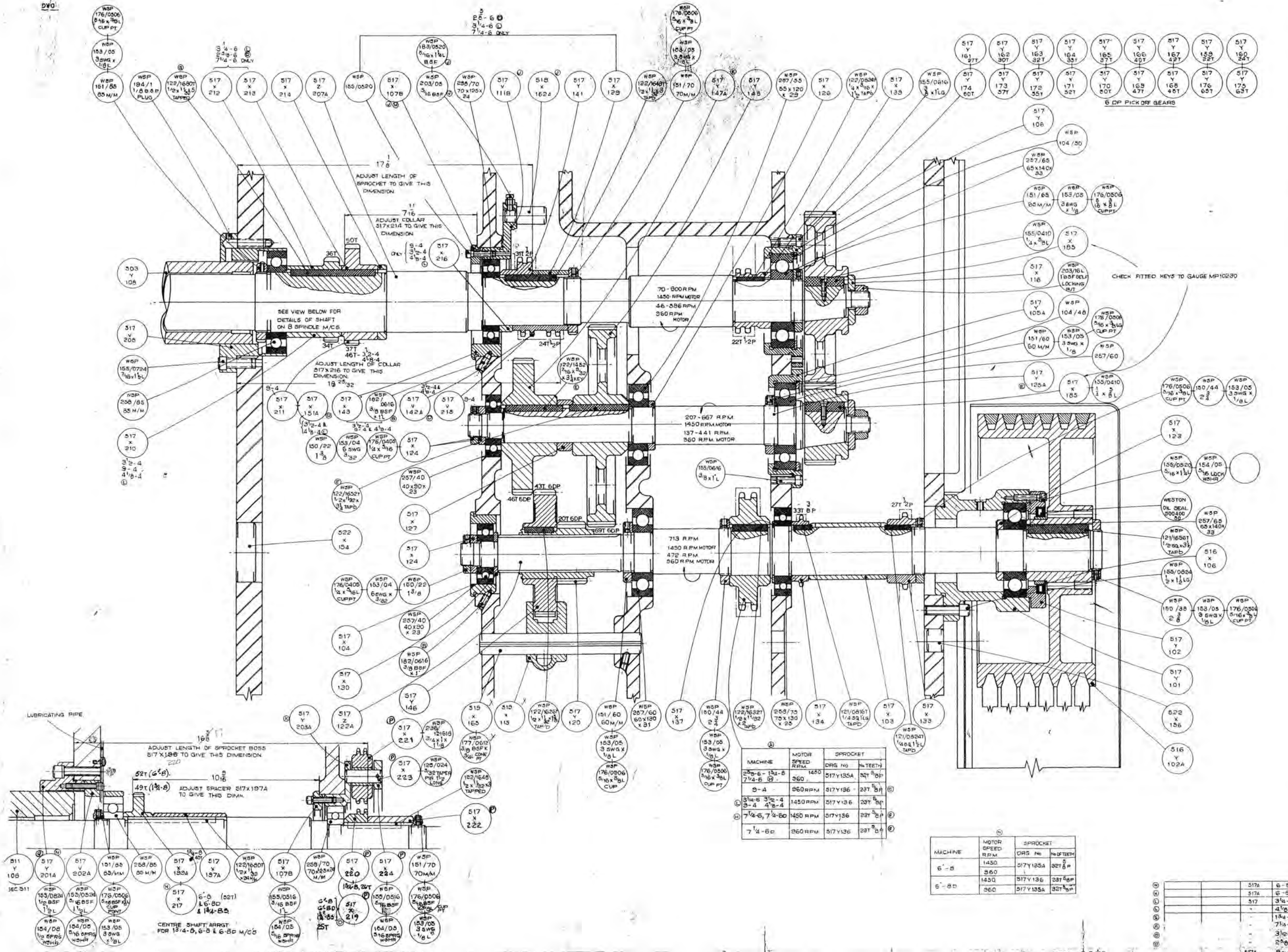

MACHINE	MOTOR SPEED RPM	SPROCKET DRG No	No OF TEETH
2 5/8 - 6 - 7 1/4 - 8	1450	517Y135A	32T 5P
3 - 4	960 RPM	517Y136	23T 5P
3 1/4 - 6 3/4 - 4	1450 RPM	517Y136	23T 5P
7 1/4 - 6, 7 1/4 - 8	1450 RPM	517Y136	23T 5P
7 1/4 - 6	960 RPM	517Y136	23T 5P

MACHINE	MOTOR SPEED RPM	SPROCKET DRG No	No OF TEETH
6 - 8	1450	517Y135A	32T 5P
6 - 8 D	960	517Y136	23T 5P
	1450	517Y135A	32T 5P

DRG No	No OF TEETH
517A	6 - 8
517A	6 - 8 D
517	3 1/4 - 6
	4 1/4 - 4
	1 1/4 - 8
	7 1/4 - 6
	3 1/4 - 4
	2 5/8 - 6
517A	9 - 4

SEC 511

CENTRE SHAFT ARRGT FOR 1 1/4 - 6, 6 - 8 & 6 - 8 D M/C'S