

**GILDEMEISTER**

**PIÈCES  
DÉTACHÉES**

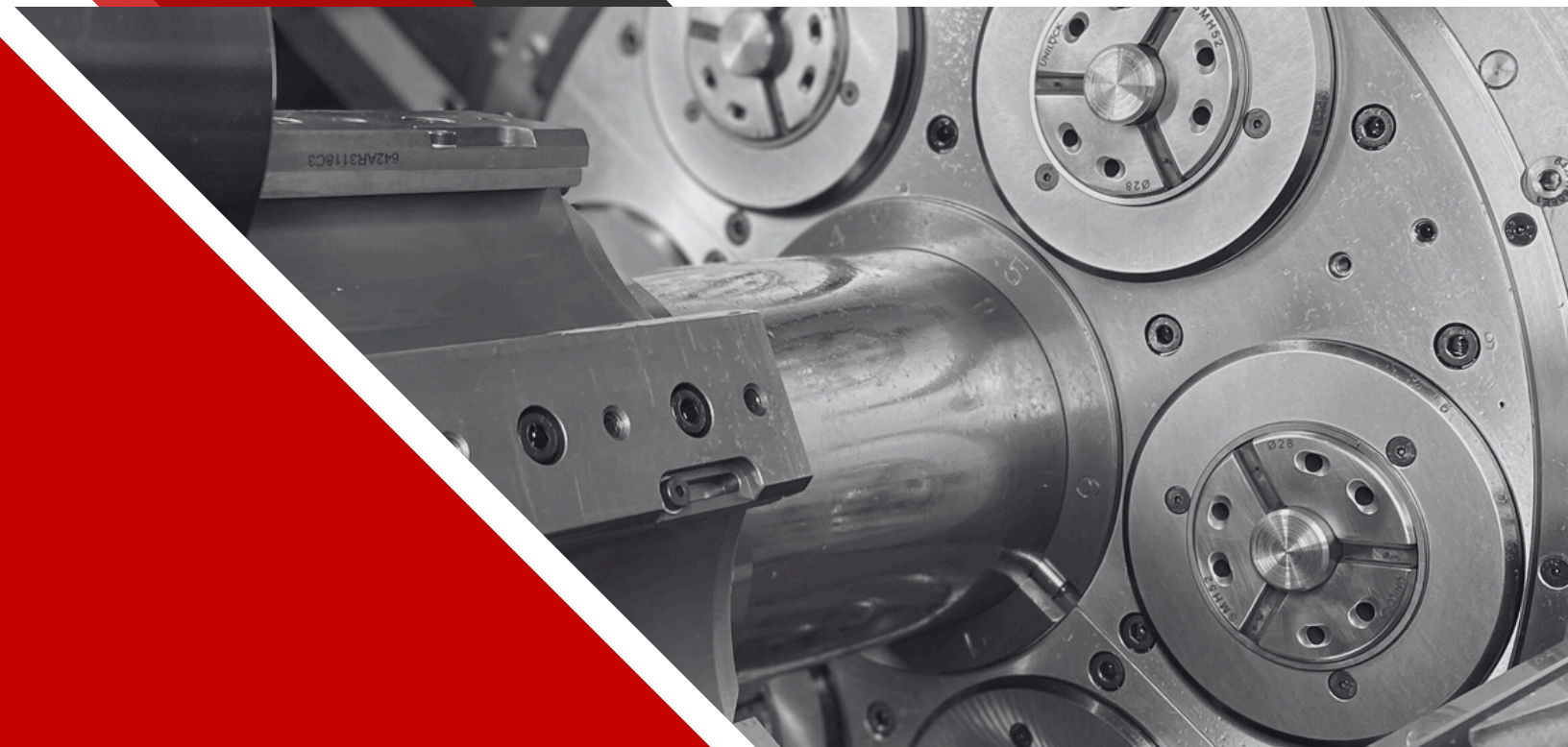

**GILDEMEISTER**

GM32

GM35

GM42

**TAJMAC-FRANCE**

# SOMMAIRE

<b>Pièces détachées</b>	<b>Page</b>
Boîte de vitesse et avance	3
Système de serrage	4
Système d'avance	5
Serrage / Avance	6
Axes et galets / Glissières axiales / Coulisses et ressorts transversaux	7
Coulisses transversales	8-12
Broche frontale	13
Broches porte-outils frontales	14
Embrayage / Butée de barre / Croix de malte	15
Arrêtage de broches / Convoyeur à copeaux	16
Arbres à cames	17
Arbre de renvoi	18
Tambour	19
Disques d'embrayages	20

<b>Appareillages</b>	<b>Page</b>
Pick-up hydraulique	21
Chariot de reprise pour usinage arrière	22
Frein pick-up	23
Embrayage taraudeur assemblé	24
Système de contrôle de taraudage	25-26
Commande indépendante frontale / Glissière axiale	27
Commande bloc central	28
Appareil à fraiser en bout	29
Appareillages	30
Rapport de pignons	31
Nos reconstructions et révisions	32
Appareillages / Pincés	33-34

# PIÈCES DÉTACHÉES

## Boîte de vitesse et avance GM 32-35-42

	Z1	Z2	
3510200	23	68	3510227
3510201	24	67	3510226
3510202	25	66	3510225
3510203	26	65	3510224
3510204	29	62	3510223
3510205	30	61	3510222
3510206	31	60	3510221
3510207	32	59	3510220
3510208	33	58	3510219
3510209	35	56	3510218
3510210	37	54	3510217
3510211	39	52	3510216
3510212	41	50	3510215
3510213	43	48	3510214



Pignons vitesses de broche, avances et rapports de taraudage



37.06.120

37.32.102

Cames standards pour glissières axiales pos. 1-2-4-5

Cames standards pour les coulisses transversales

37.29.109  
37.29.108  
37.29.107  
37.29.106  
37.29.105  
37.29.104  
37.29.103  
37.29.102

# Système de serrage GM 32-35



# Systeme d'avance GM 32-35



3701230



3701233



3701127



3701231



3501145



90696

Pince de serrage GM 32-35

3501148  
3760114

Tube de serrage  
Tube de serrage pour machine  
arrêt de broche



3501109

3501108

3501110



3701146 Tube d'avance GM 35  
3501149 Tube d'avance GM 32



9336E

Pince d'avance GM 32

9335E

Pince d'avance GM 35

# Serrage / Avance GM 42



4001113



4001109



4001111



4001159



4001129



4001162

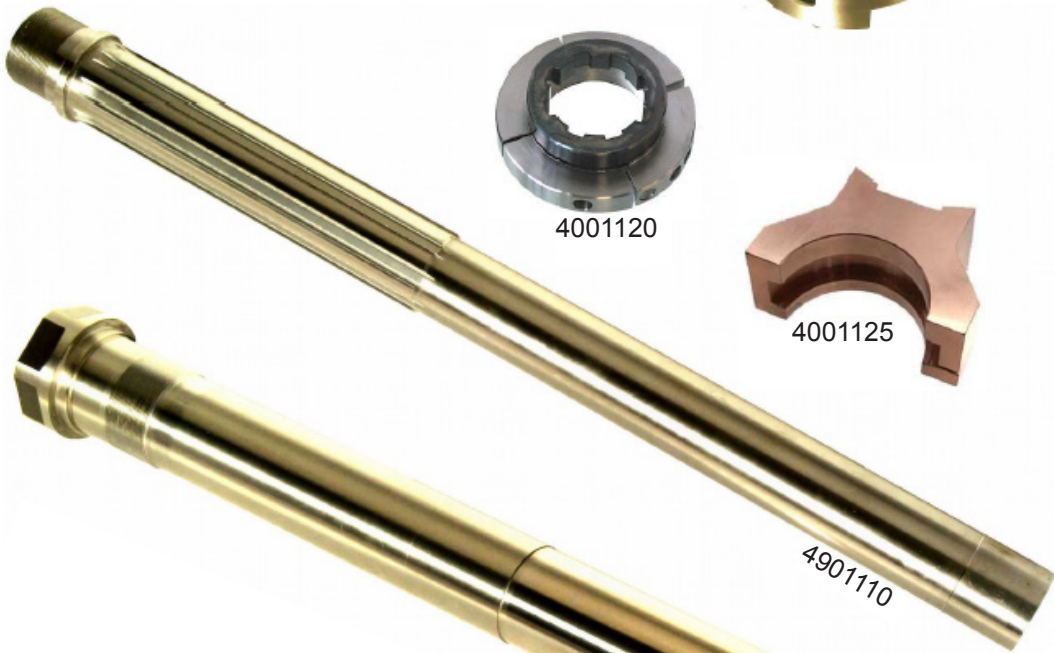

4901110



4001120



4001125

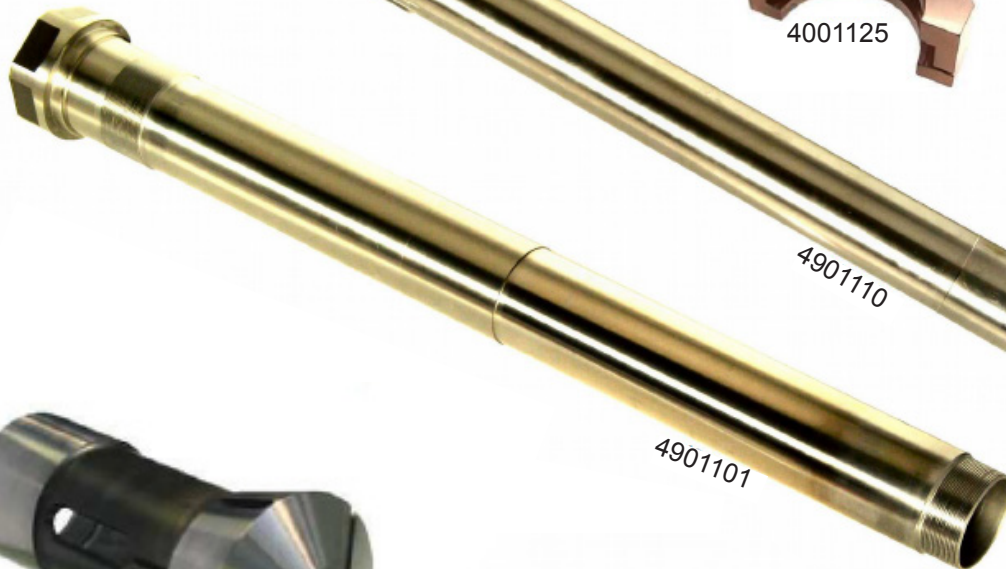

4901101



9115E  
Pince de serrage



9374E  
Pince d'avance

# Axes et galets GM 32-35-42

Axe / Galet leviers frontaux pos. 1/2/3/4/5/6  
Réf : 06 67 94

Axe / Galet de coulisse pos. 1/2/4/5  
Réf : 06 67 93

Axe / Galet de coulisse pos. 3/6  
Réf : 06 67 92



# Glissières axiales GM 32-35-42



# Coulisses et ressorts transversaux GM 32-35-42

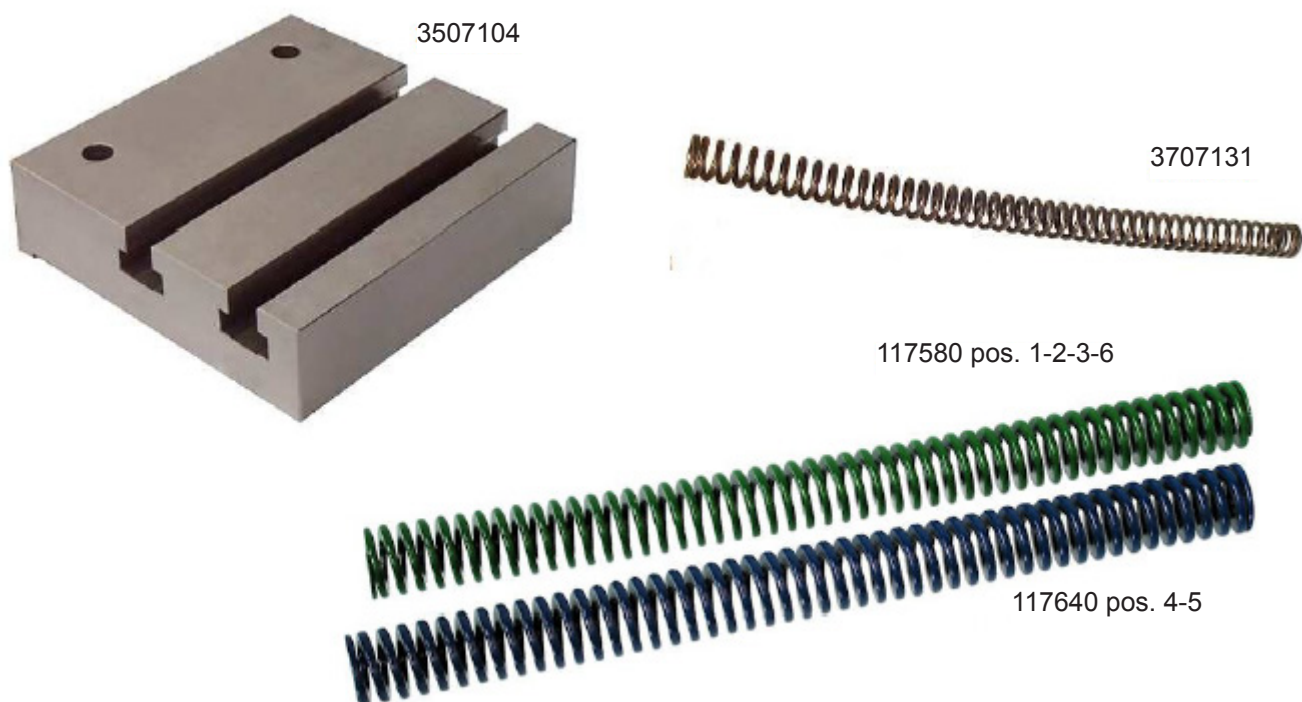

# Coulisse transversale pos. 1 GM 32-35-42



# Coulisse transversale pos. 2



# Coulisse transversale pos. 3 GM 32-35-42



# Coulisse transversale pos. 4 GM 32-35-42



3707143

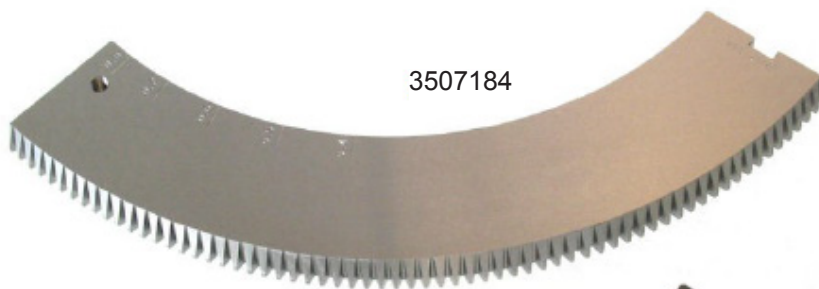

3507184



3507125

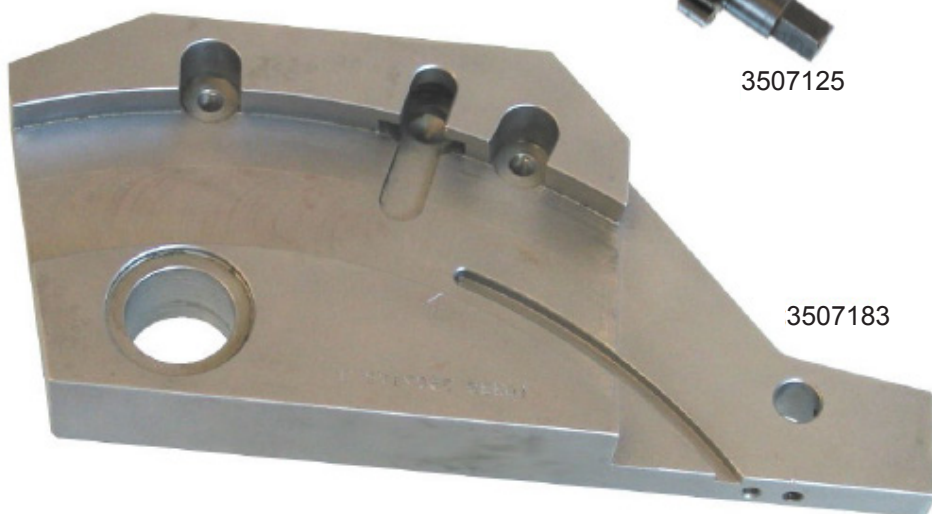

3507183



3507185



3507177



3507176



3507157



3707123



3507156



3507180



3507179

# Coulisse transversale pos. 5 GM 32-35-42

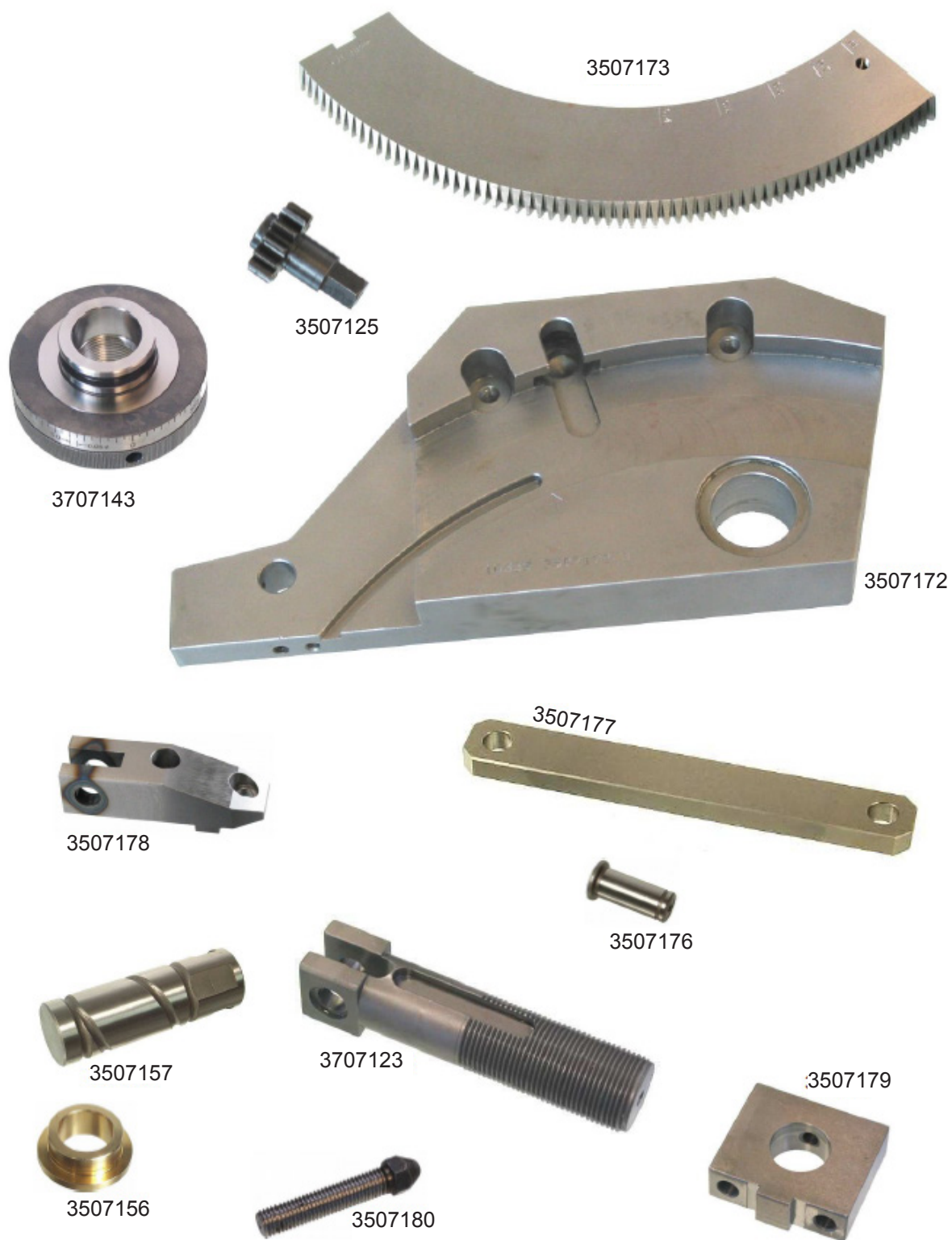

# Coulisse transversale pos. 6 GM 32-35-42



# Broche frontale GM 32-35-42



# Broches porte-outils frontales GM 32-35-42



3723044

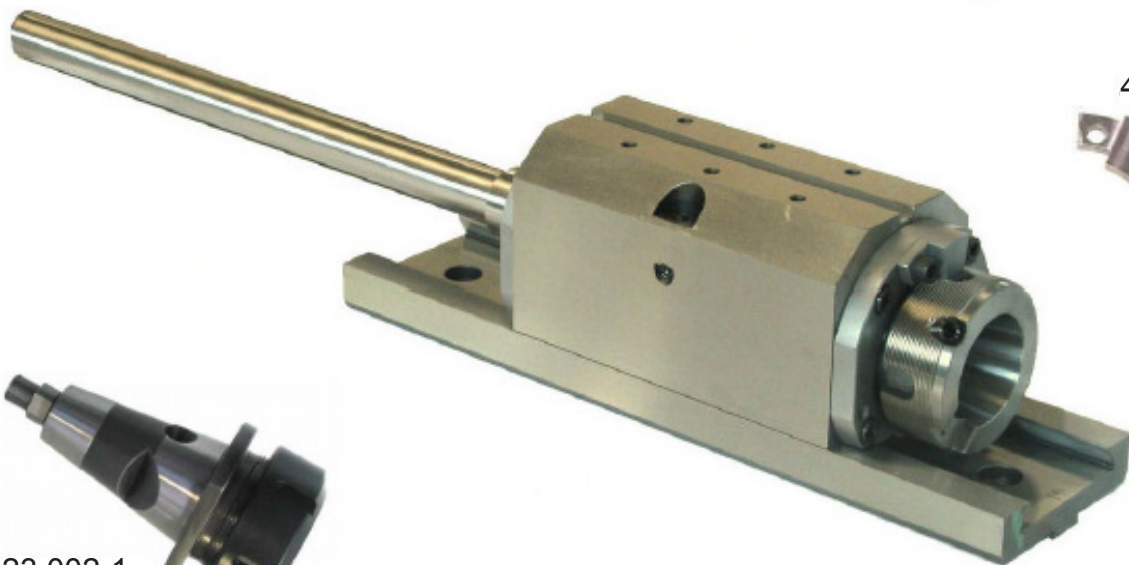

4923144



49.23.002-1

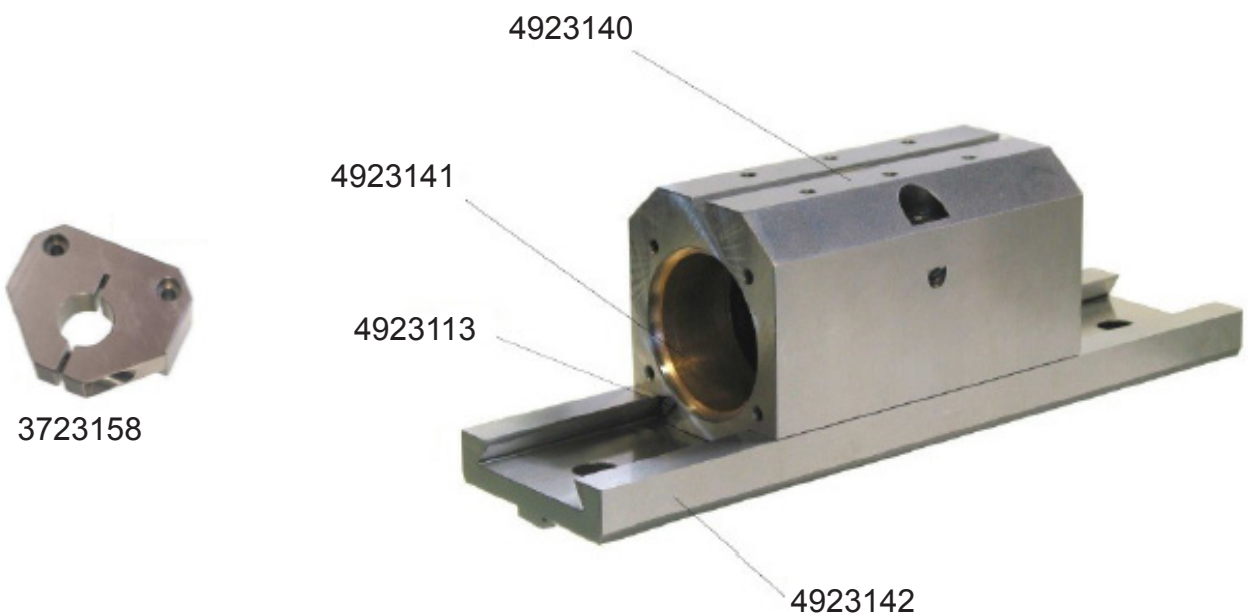

4923140

4923141

4923113

4923142



3723158

# Embrayage GM 32-35-42



3510186

# Butée de barre GM 32-35-42

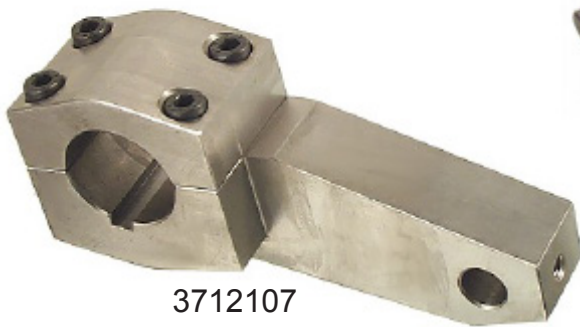

3712107  
4912103



3712111

3712110



3512116  
4912101

# Croix de malte GM 32-35-42



3504113

3504118

3504115

3504116



4904117  
3504112

# Arrêtage de broches GM 32-35-42

0-300-609-31-156-000

Double embrayage mécanique



4960176



3760241



3701135



3503107

## Convoyeur à copeaux



1551301



1551303

# Arbres à cames GM 32-35-42



# Arbre de renvoi GM 32-35-42

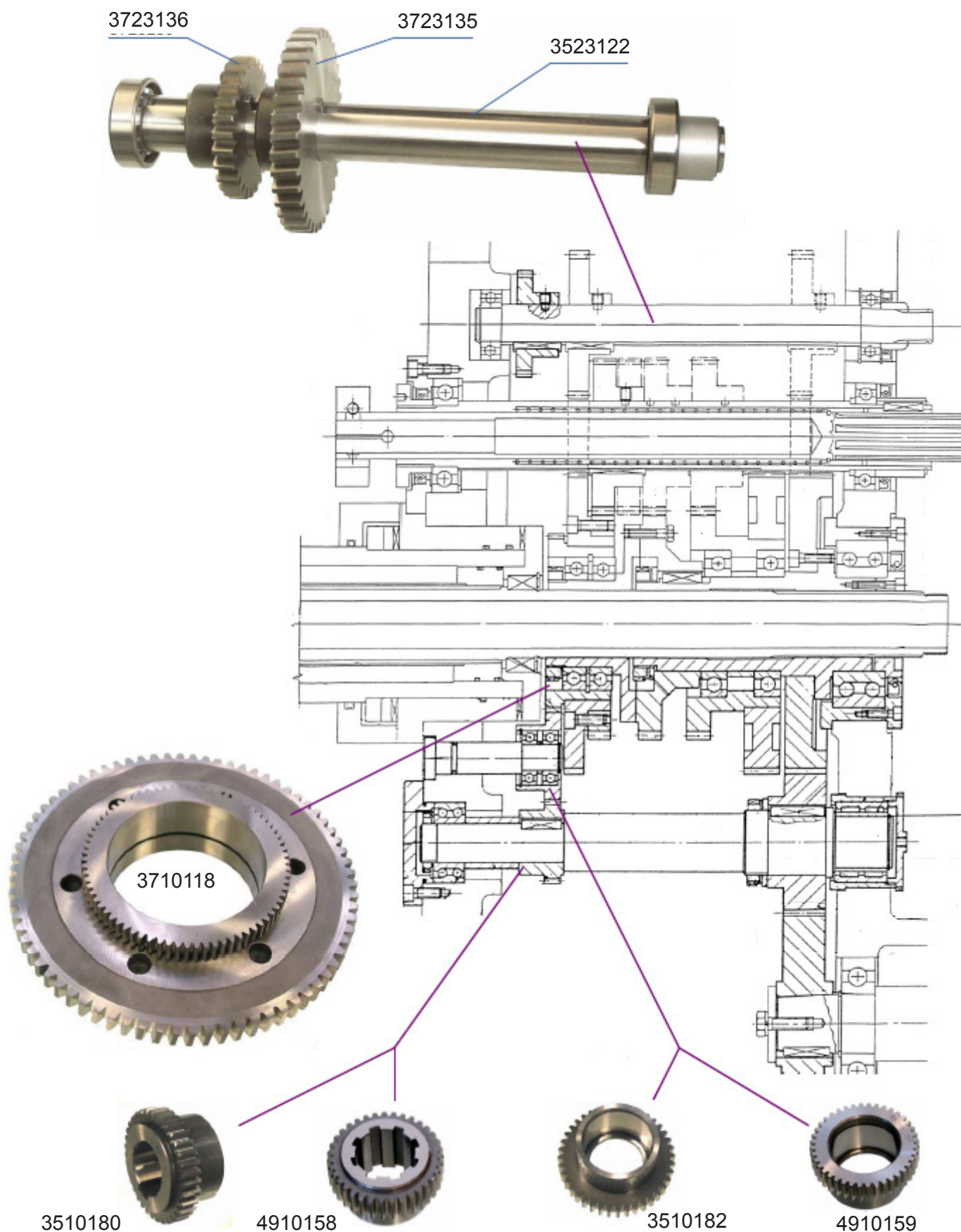

# Tambour GM 32-35-42



# Disques d'embrayages GM 32-35-42

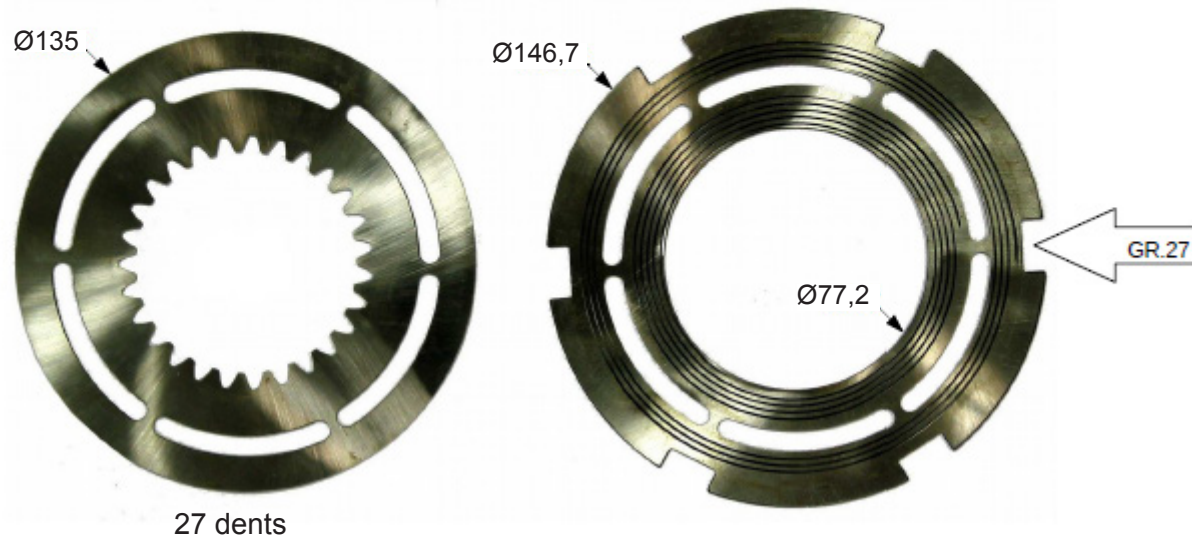
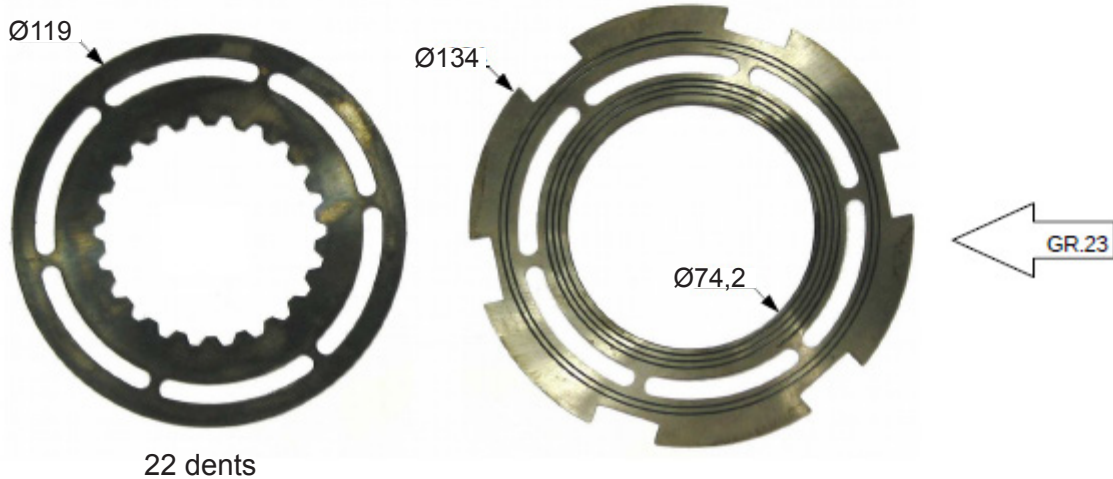
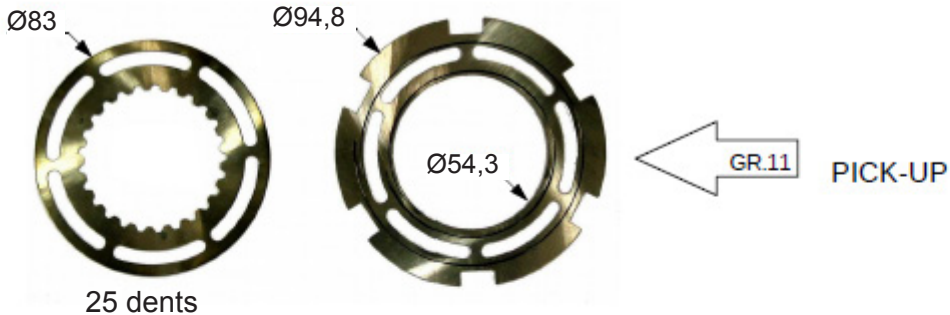

# APPAREILLAGES

## Pick-up hydraulique pos. 6 GM 32-35-42

Ce pick-up hydraulique double effet avec serrage et desserrage hydraulique est utilisé sur la position 6 sur le bloc central.

Réf : 49.58.003

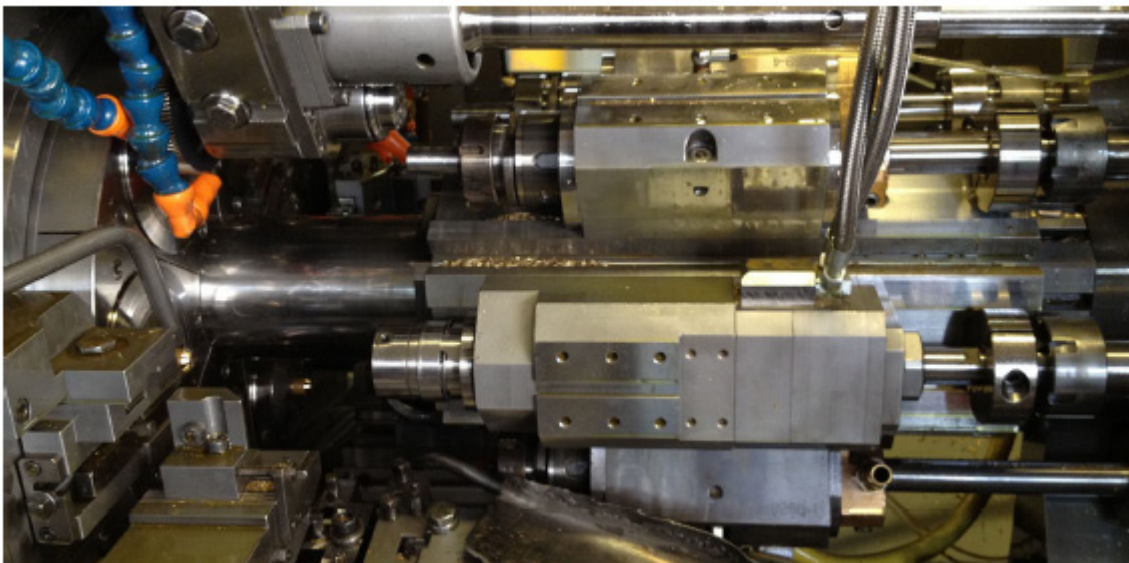
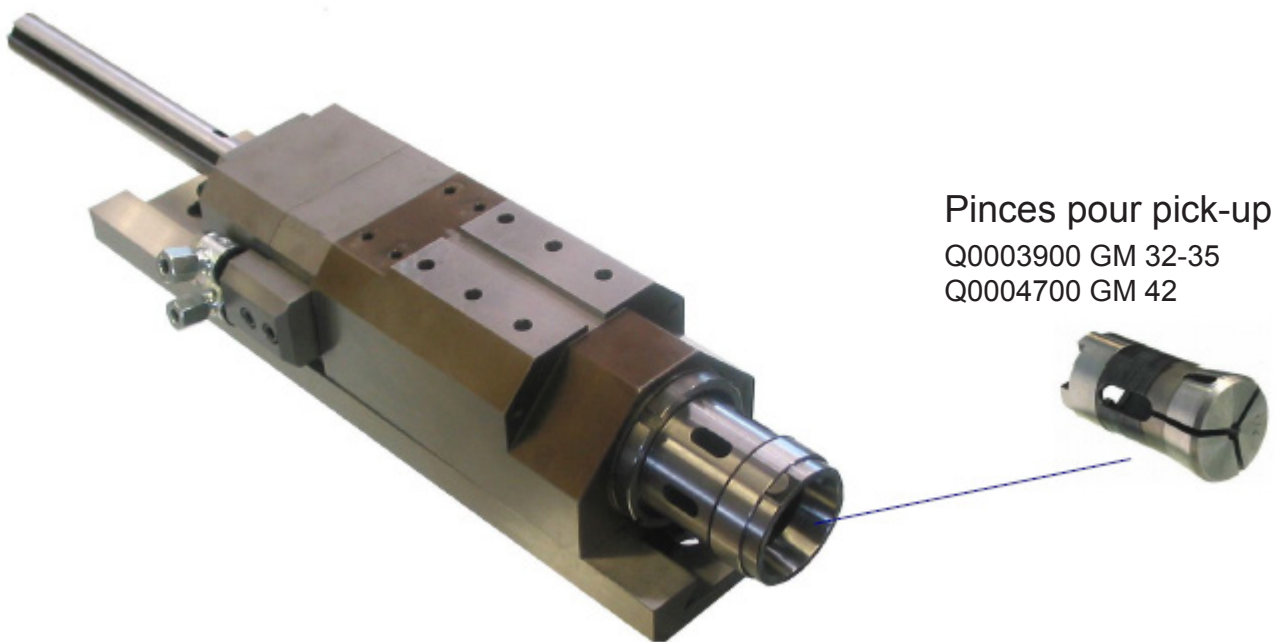

# Chariot de reprise pour usinage arrière pos. 6 GM 32-35-42

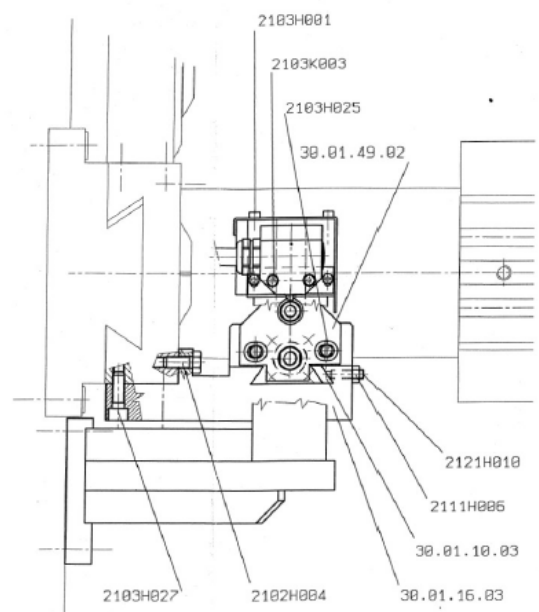
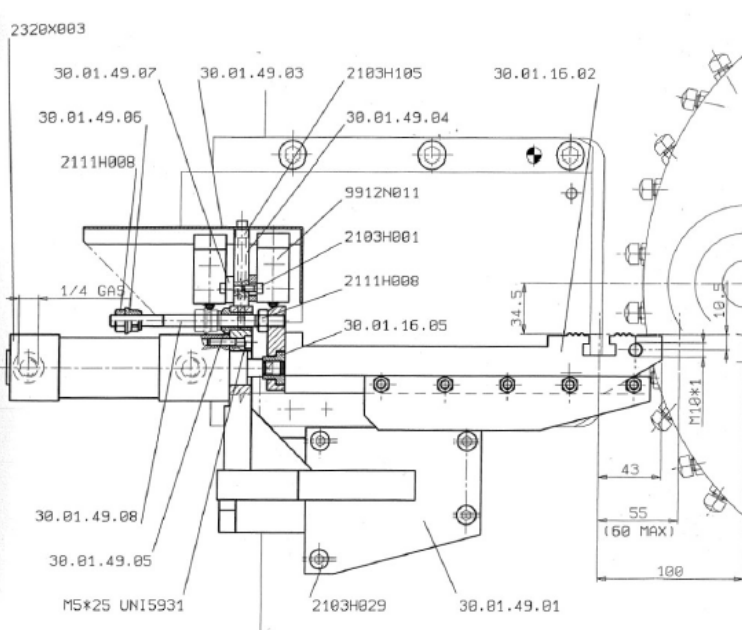
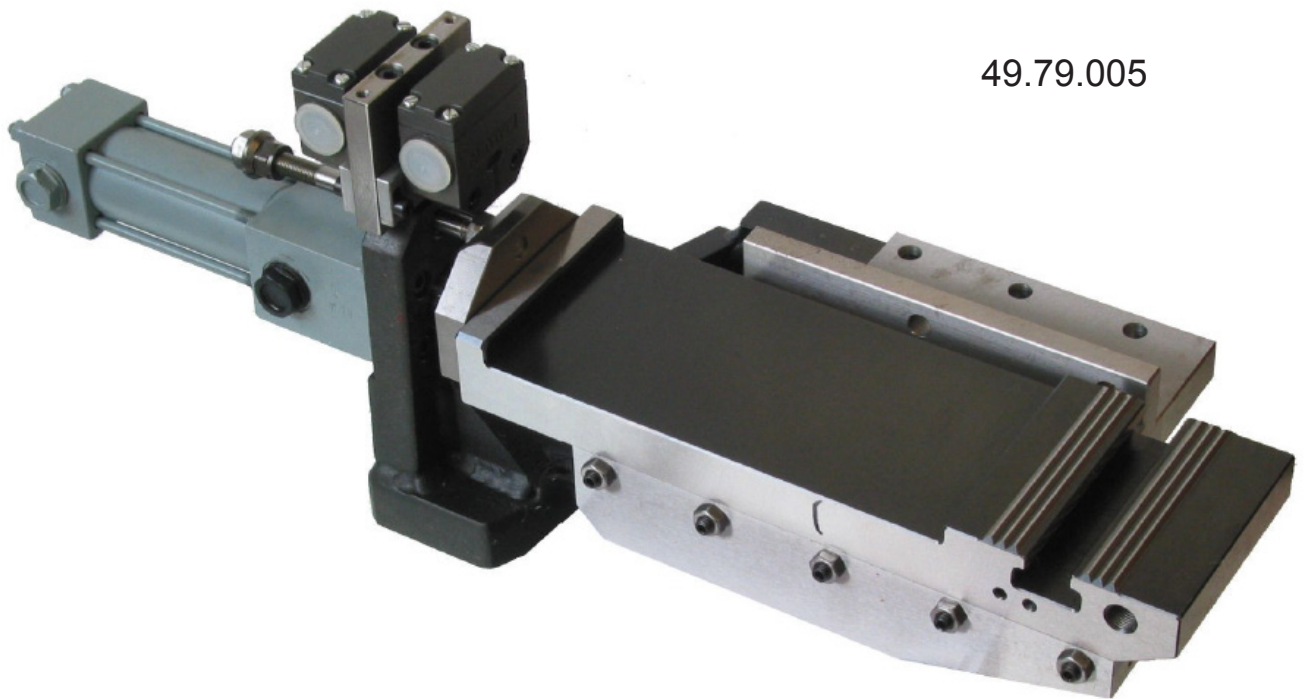

# Frein pick-up pos. 6 GM 32-35-42

37.58.004

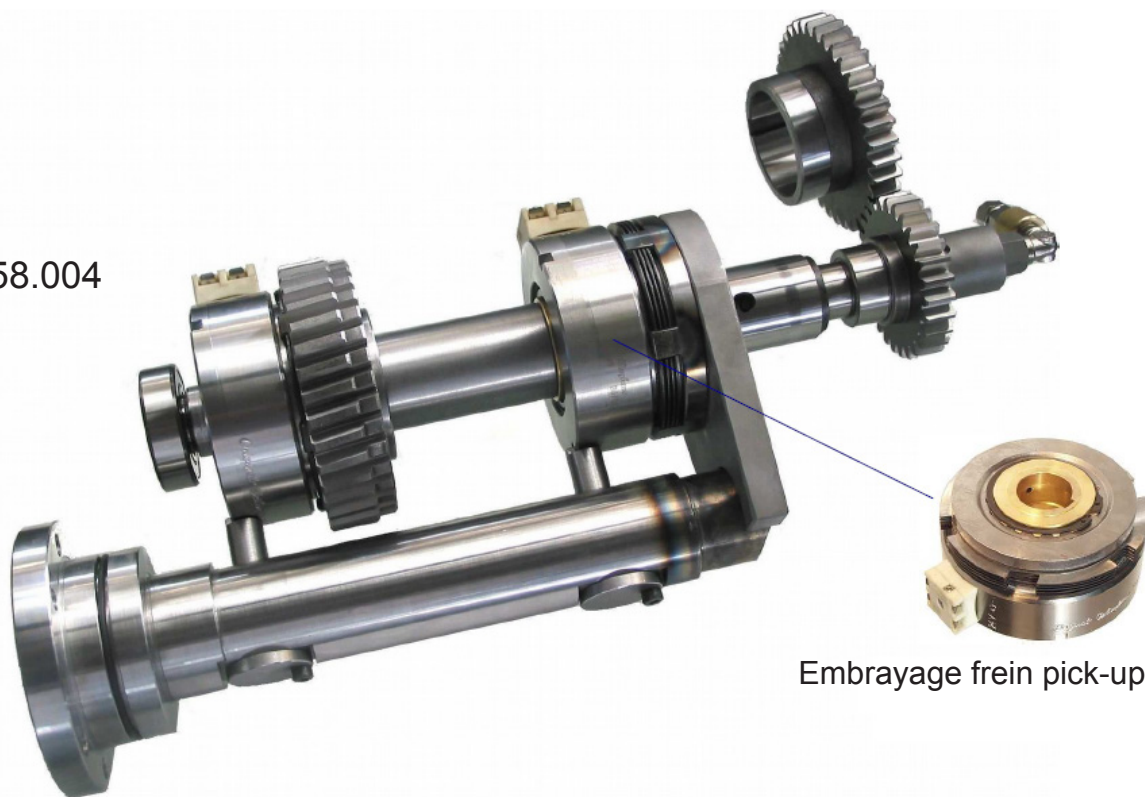

Embrayage frein pick-up

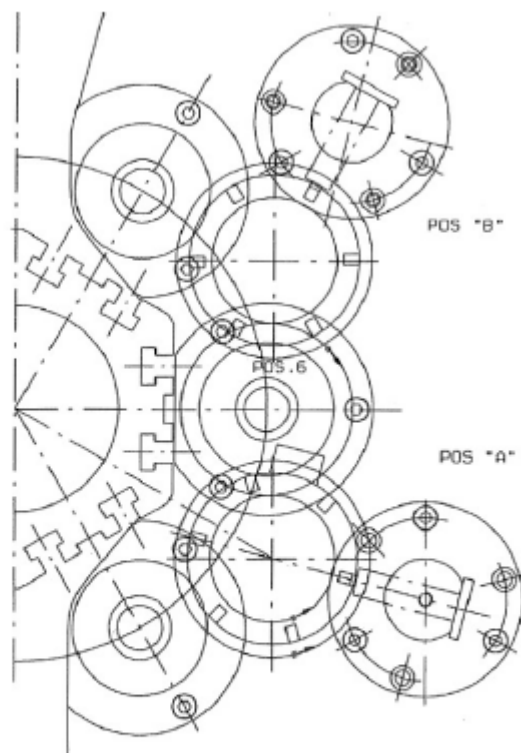
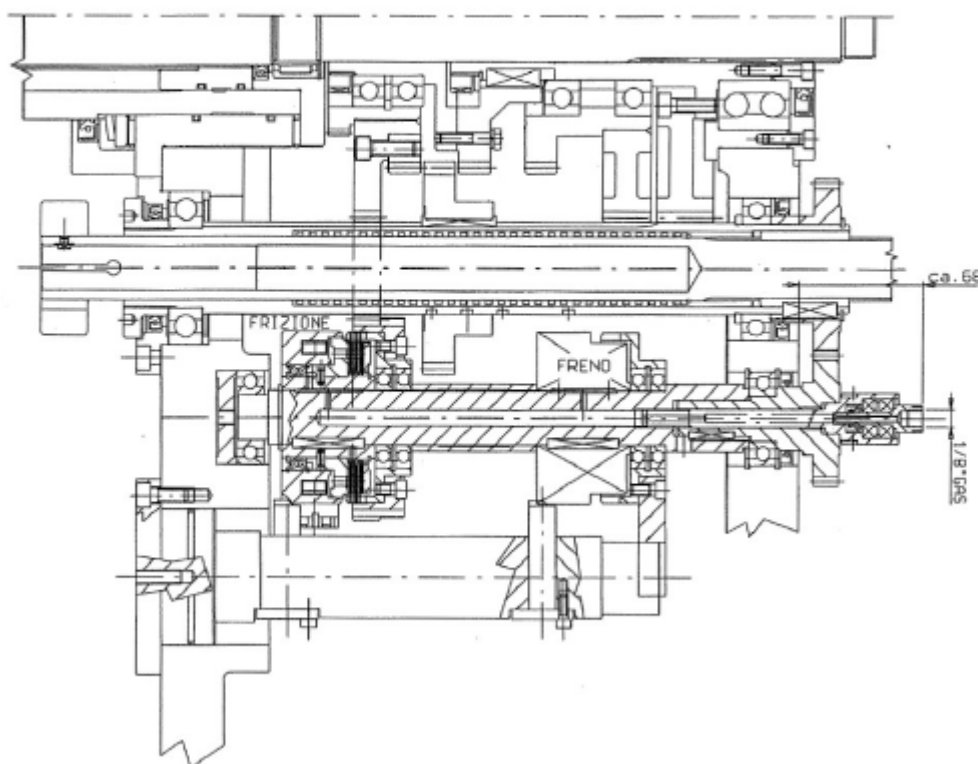

# Embrayage taraudeur assemblé

## GM 32-35-42

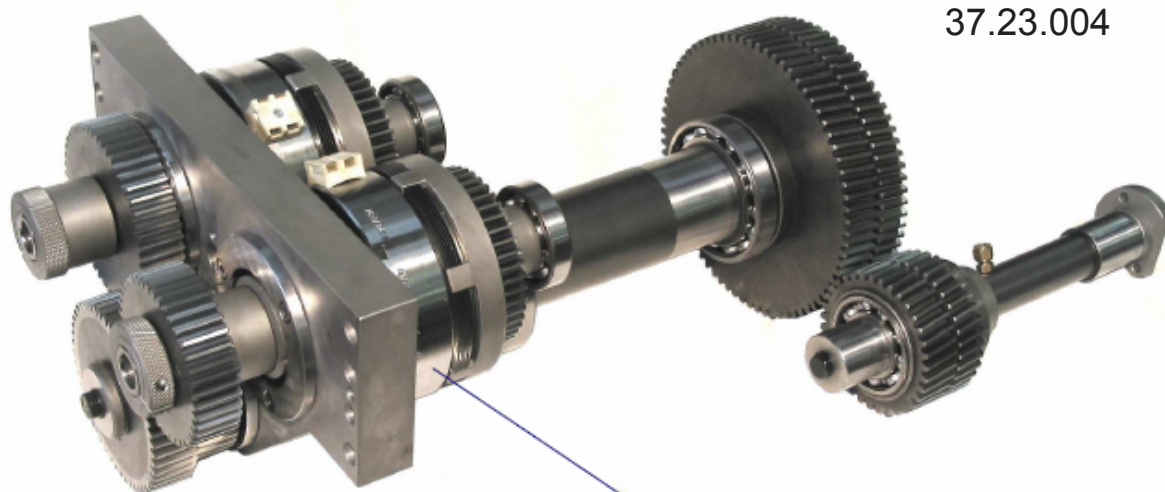

37.23.004



22.07.278  
Embrayage Ortlinghaus

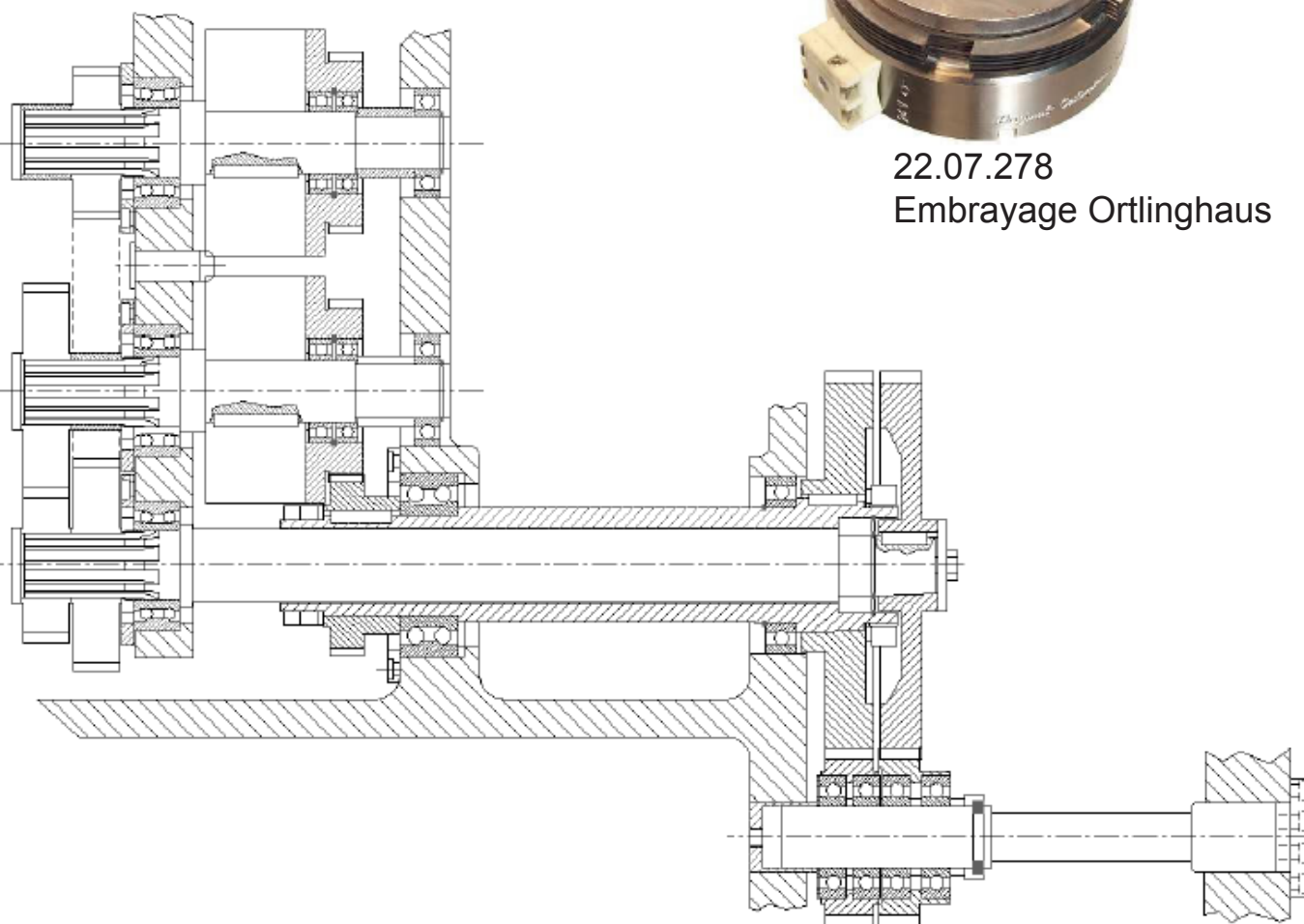

# Système de contrôle de taraudage GM 32-35-42

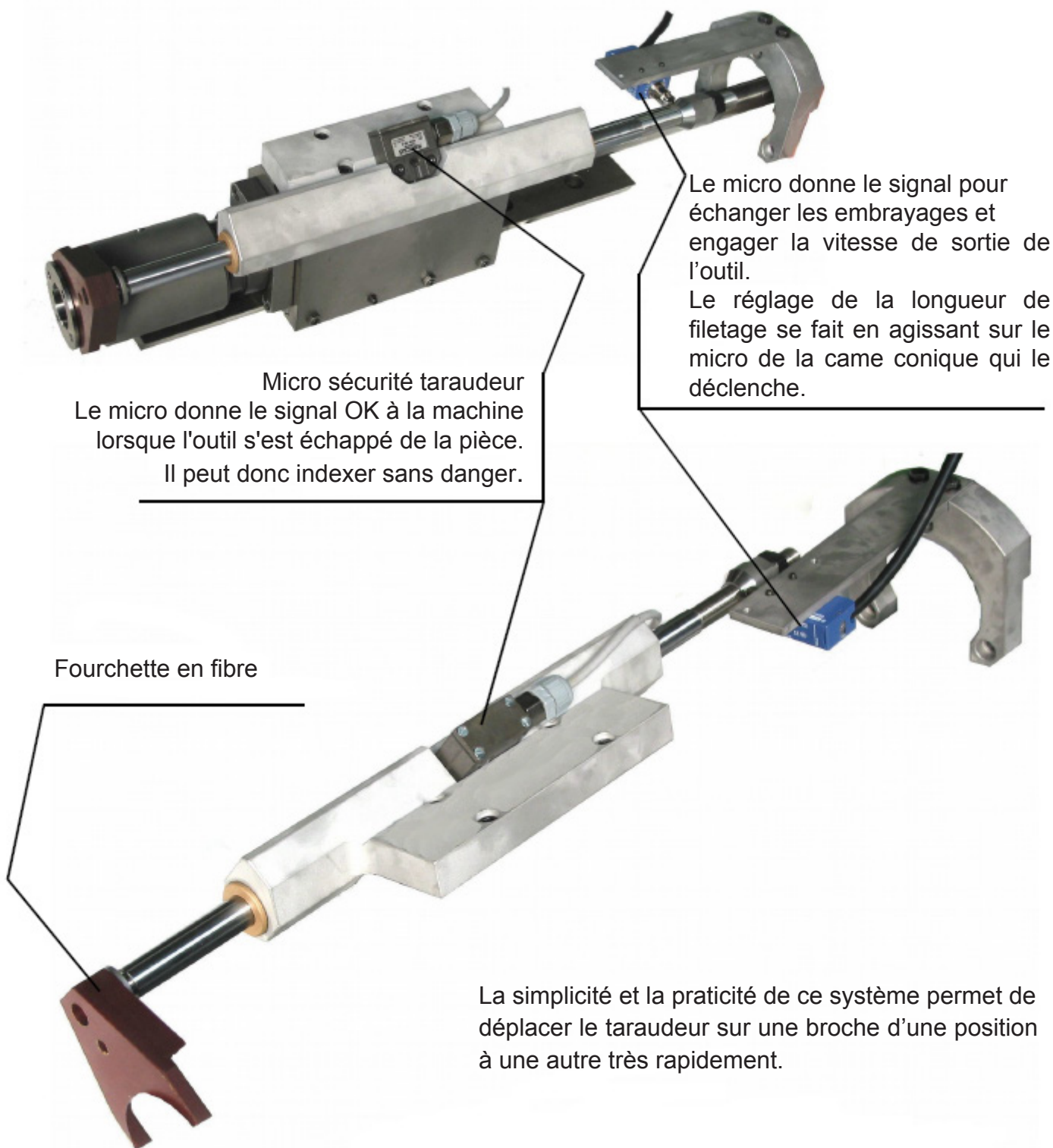

Micro sécurité tarauteur  
Le micro donne le signal OK à la machine  
lorsque l'outil s'est échappé de la pièce.  
Il peut donc indexer sans danger.

Le micro donne le signal pour  
échanger les embrayages et  
engager la vitesse de sortie de  
l'outil.  
Le réglage de la longueur de  
filetage se fait en agissant sur le  
micro de la came conique qui le  
déclenche.

Fourchette en fibre

La simplicité et la praticité de ce système permet de  
déplacer le tarauteur sur une broche d'une position  
à une autre très rapidement.

# Système de contrôle de taraudage d'origine GM 32-35-42



37.36.007  
Ensemble de porte taraud rétractable



75.03.34  
Fourchette en fibre



Porte-pince ER32



05.74.93  
Optocoupleur

# Option : Commande indépendante frontale GM 32-35-42

Commande axiale GM 32 35 42  
HIRTH

Pos. 1: 49 25 013  
Pos. 2: 49 25 014  
Pos. 4: 49 25 015  
Pos. 5: 49 25 016

Commande axiale GM 32 35 42  
Standard

Pos. 1: 49 25 005  
Pos. 2: 49 25 006  
Pos. 4: 49 25 007  
Pos. 5: 49 25 008

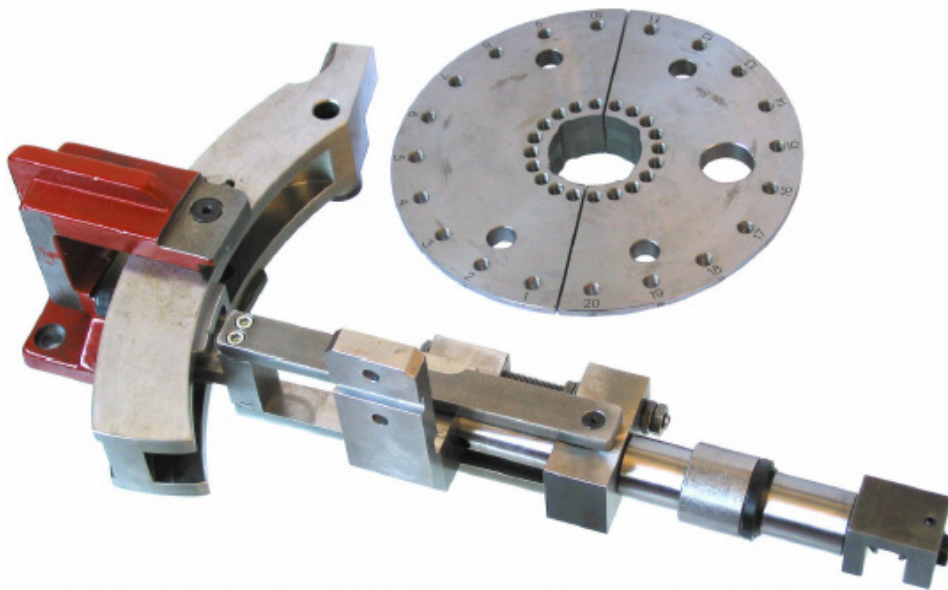

## Glissière axiale avec rainures en T

49.25.019 Pos. 1  
49.25.020 Pos. 2  
49.25.017 Pos. 4  
49.25.018 Pos. 5

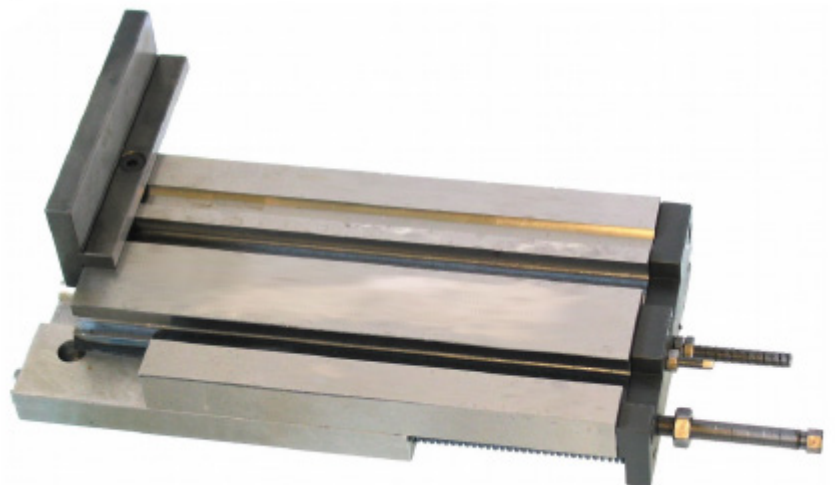

# Commande bloc central GM 32-35-42

49.11.002

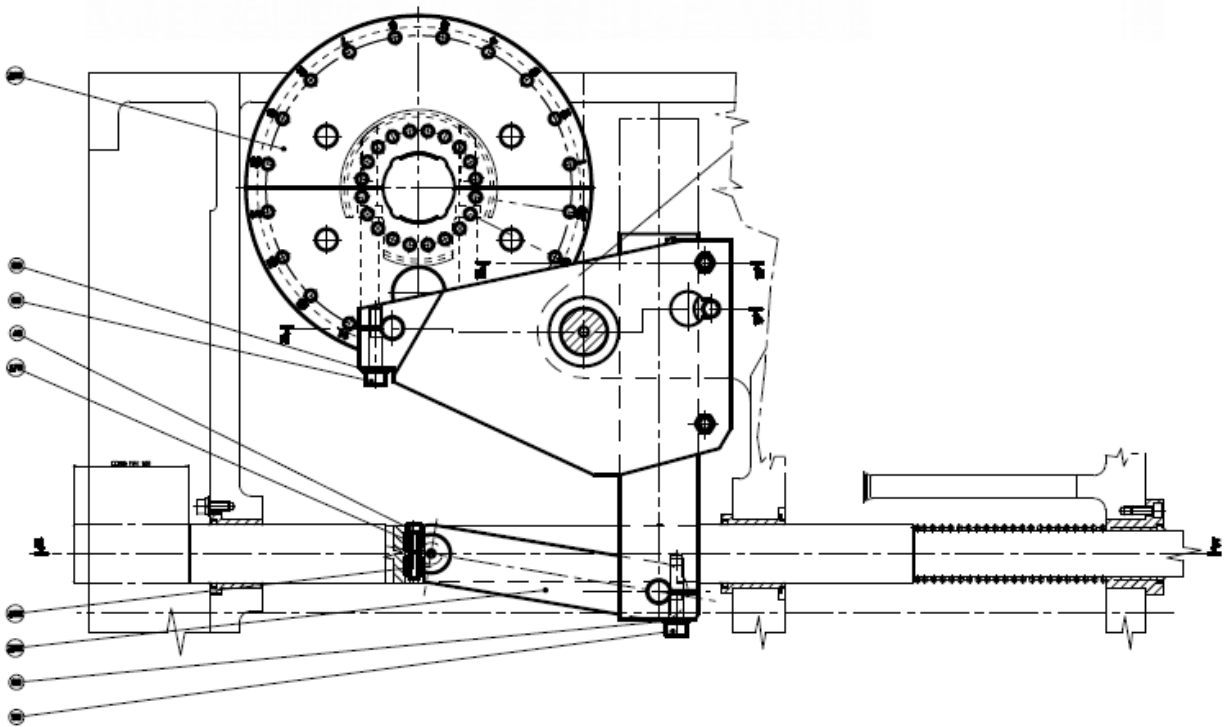
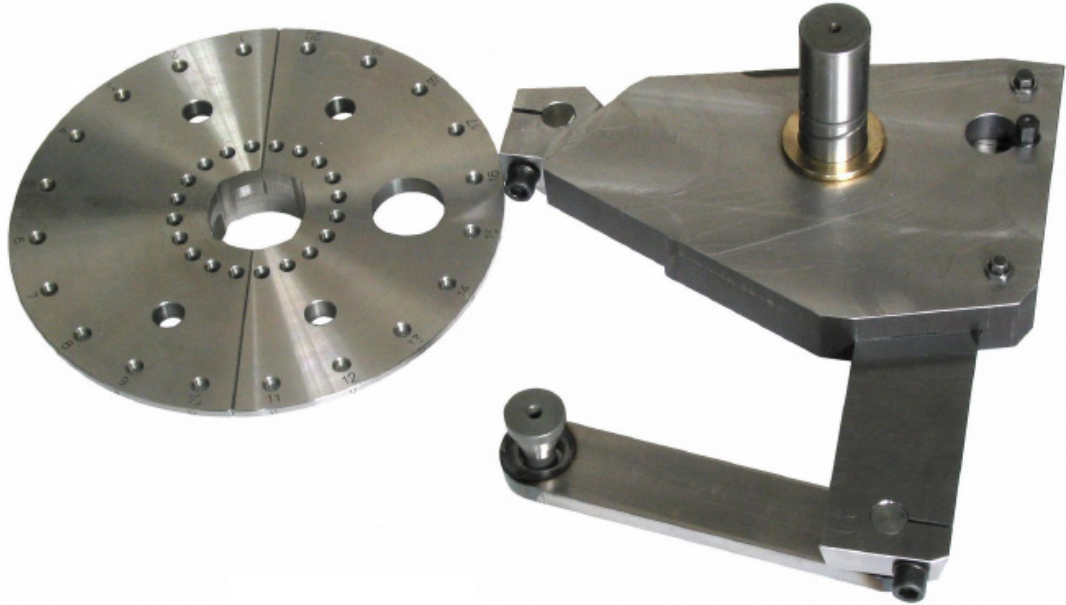

# Appareil à fraiser en bout GM 32-35-42

37.55.001



Vitesse maximale : 2 000 rpm

Diamètre max pour le disque de fraiseage : 80 mm

Distance max entre les 2 disques de fraiseage : 33.5 mm

La vitesse de rotation de l'outil peut être modifiée en remplaçant le rapport de transmission dans la boîte arrière.

Ce type d'appareillage doit être fixé sur le bloc central, par conséquent, la machine doit être équipée de la came pour déplacer le bloc central.

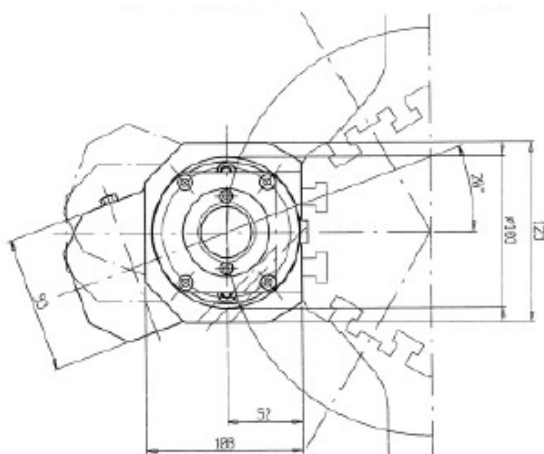
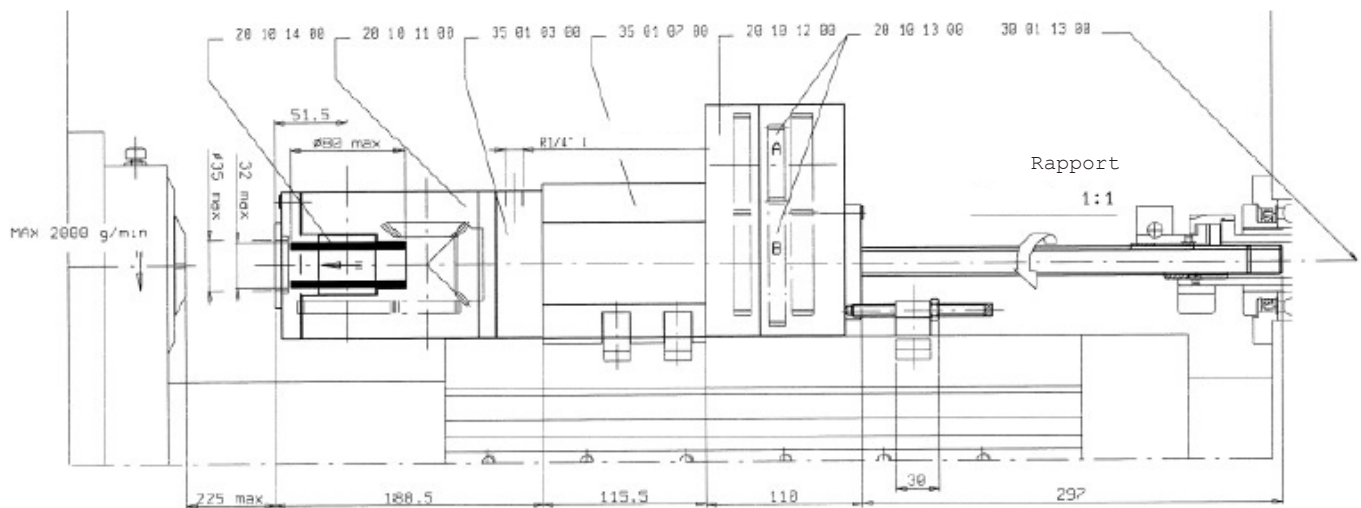

Roues interchangeables 20 10 13 00				
N° conception de la roue « A »	Z A	N° conception de la roue « B »	Z B	Rapport Broche/Fraise
20 10 13 01	25	20 10 13 18	44	1 : 3.74
20 10 13 02	26	20 10 13 17	43	1 : 4.11
20 10 13 03	27	20 10 13 16	42	1 : 4.60
20 10 13 04	28	20 10 13 15	41	1 : 5.23
20 10 13 05	29	20 10 13 14	40	1 : 6.13
20 10 13 06	30	20 10 13 13	39	1 : 7.46
20 10 13 07	31	20 10 13 12	38	1 : 9.70
20 10 13 08	32	20 10 13 11	37	1 : 14.08

# Appareillages

Appareil à peigner



Appareil à polygoner et fraiser les filets



Pick-up pos.6



Taraudeur

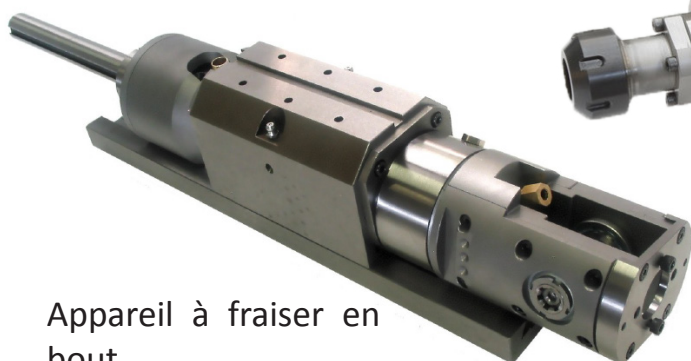

Appareil à fraiser en bout

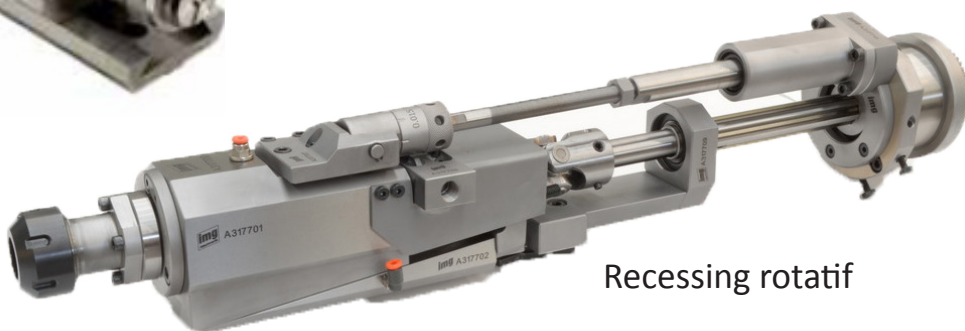

Recessing rotatif

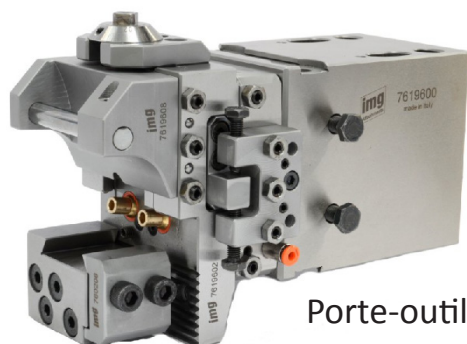

Porte-outil à raser

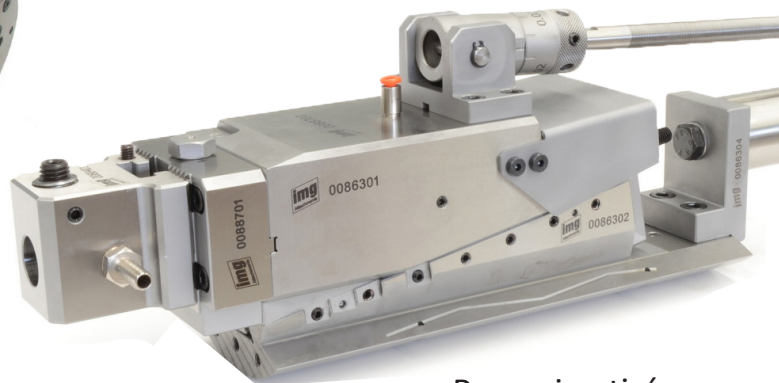

Recessing tiré

# Option : Rapport de pignons pour le perçage et le forage à grande vitesse GM 32-35-42

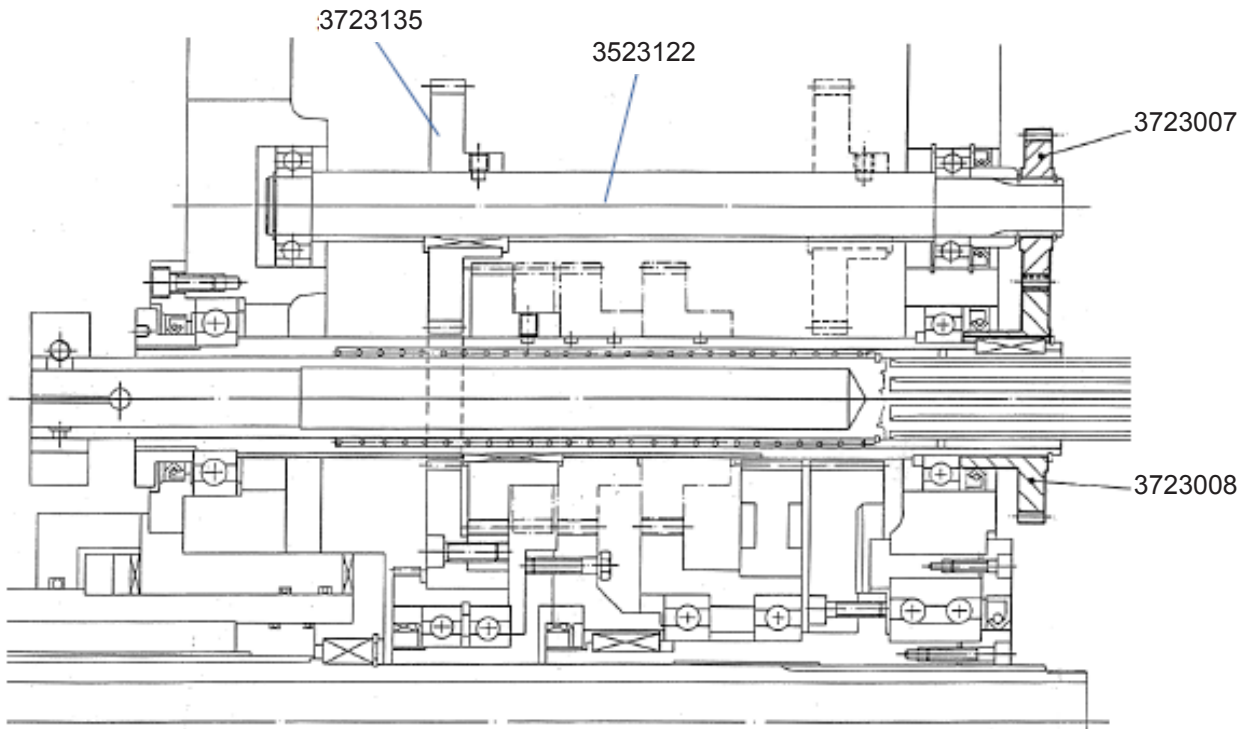

3723007	Z1	Z2	3723008
3723118	17	49	3723133
3723119	20	46	3723132
3723120	22	44	3723131
3723121	24	42	3723130
3723122	25	41	3723129
3723123	35	31	3723128
3723124	37	29	3723127
3723125	39	27	2723126

# Nos reconstructions et révisions GM32-GM35-GM42



Gildemeister GM42

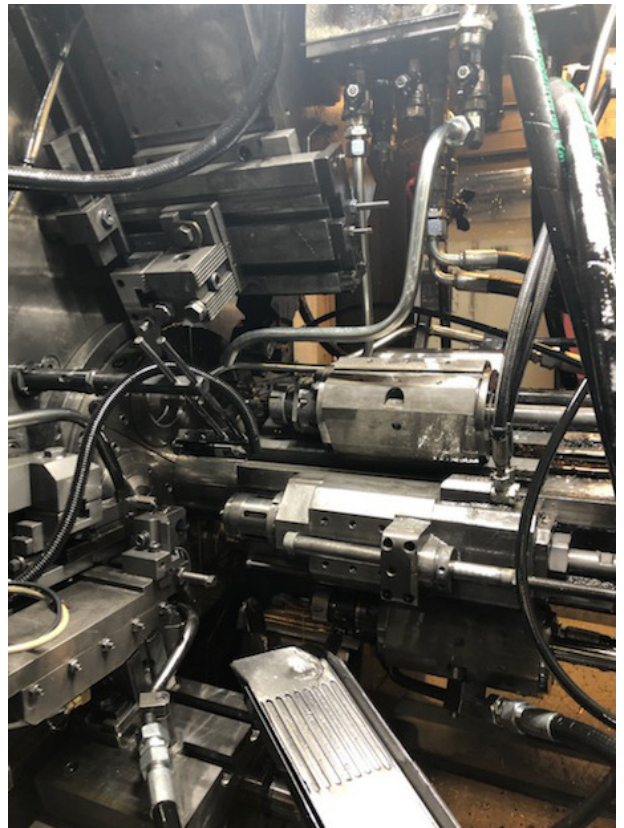

Intérieur GM32

Nous assurons la reconstruction de vos machines ainsi que les révisions nécessaires.

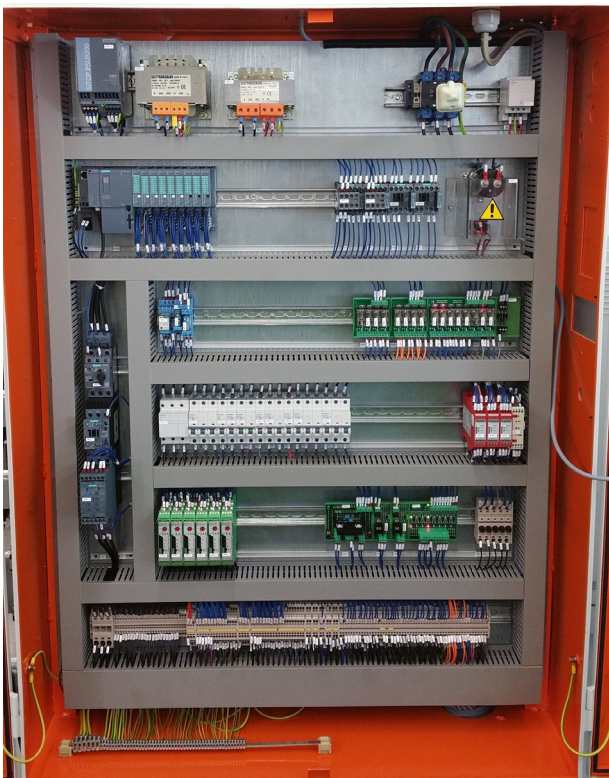

Armoire électrique Gildemeister  
AS20-GS20-GM20



Panneau de commande Gildemeister  
AS20-GS20-GM20

# Votre partenaire pour l'équipement des tours automatiques



Disposant d'une grande expérience et moyens techniques importants, Tajmac-France vous propose la fourniture des appareillages, la révision partielle, la reconstruction complète de vos tours Gildemeister, ainsi que l'assistance sur site.

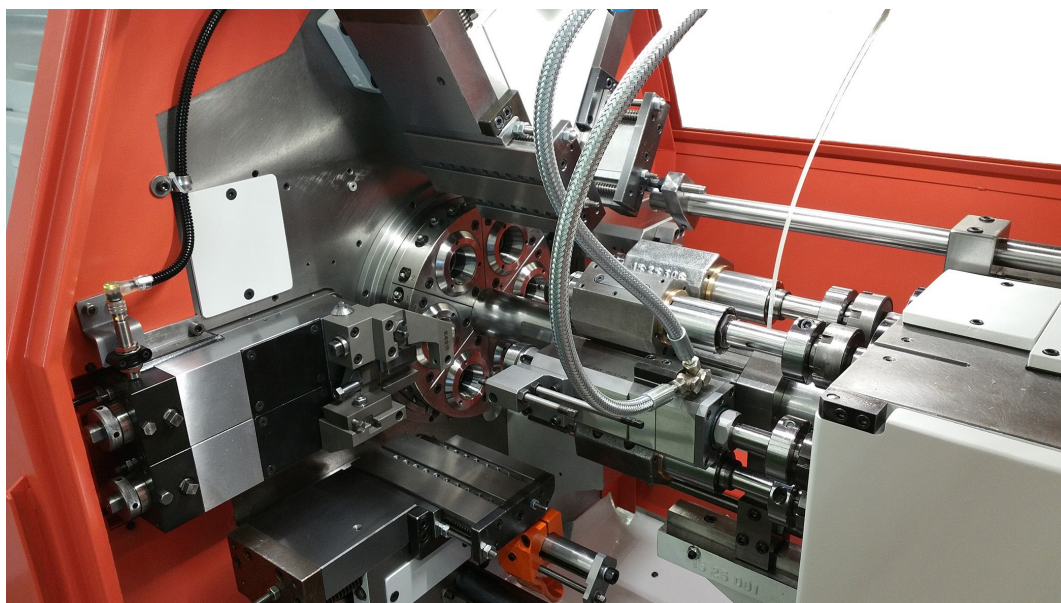

# Votre partenaire pour l'équipement des tours automatiques

- Appareillages IMG, SACO pour les tours GILDEMEISTER, WICKMAN, MORI-SAY, SCHÜTTE et TORNOS.

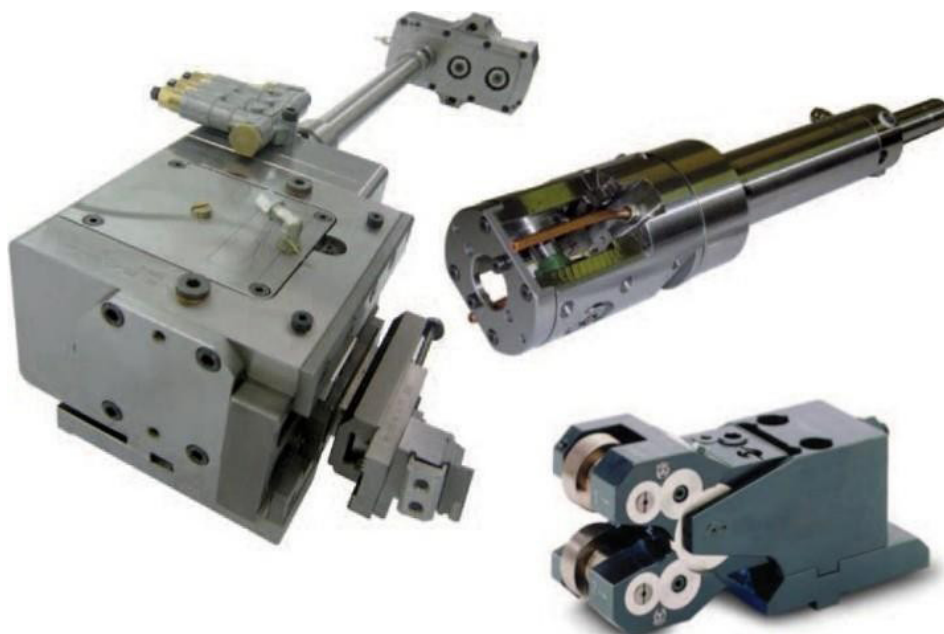

- Pinces de serrage, pinces d'avance, pinces pick-up pneumatiques / hydrauliques pour les tours multibroches GILDEMEISTER et multibroches autres marques, pinces embarreurs.



# Plan d'accès

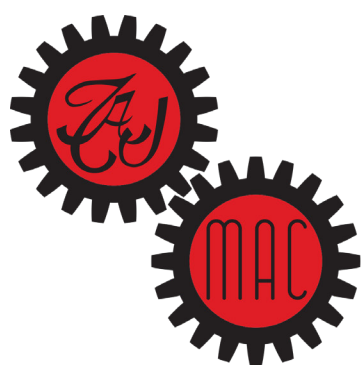

**TAJMAC**  
G R O U P





# TAJMAC - FRANCE



85 Rue Marie Curie  
ZAC des Grands Bois  
74130 VOUGY

Tel. (+33)4 50 34 00 41  
Fax. (+33)4 50 34 04 43

[www.tajmac-france.com](http://www.tajmac-france.com)  
[info@tajmac-france.com](mailto:info@tajmac-france.com)

