

**GILDEMEISTER**

**PIÈCES  
DÉTACHÉES**

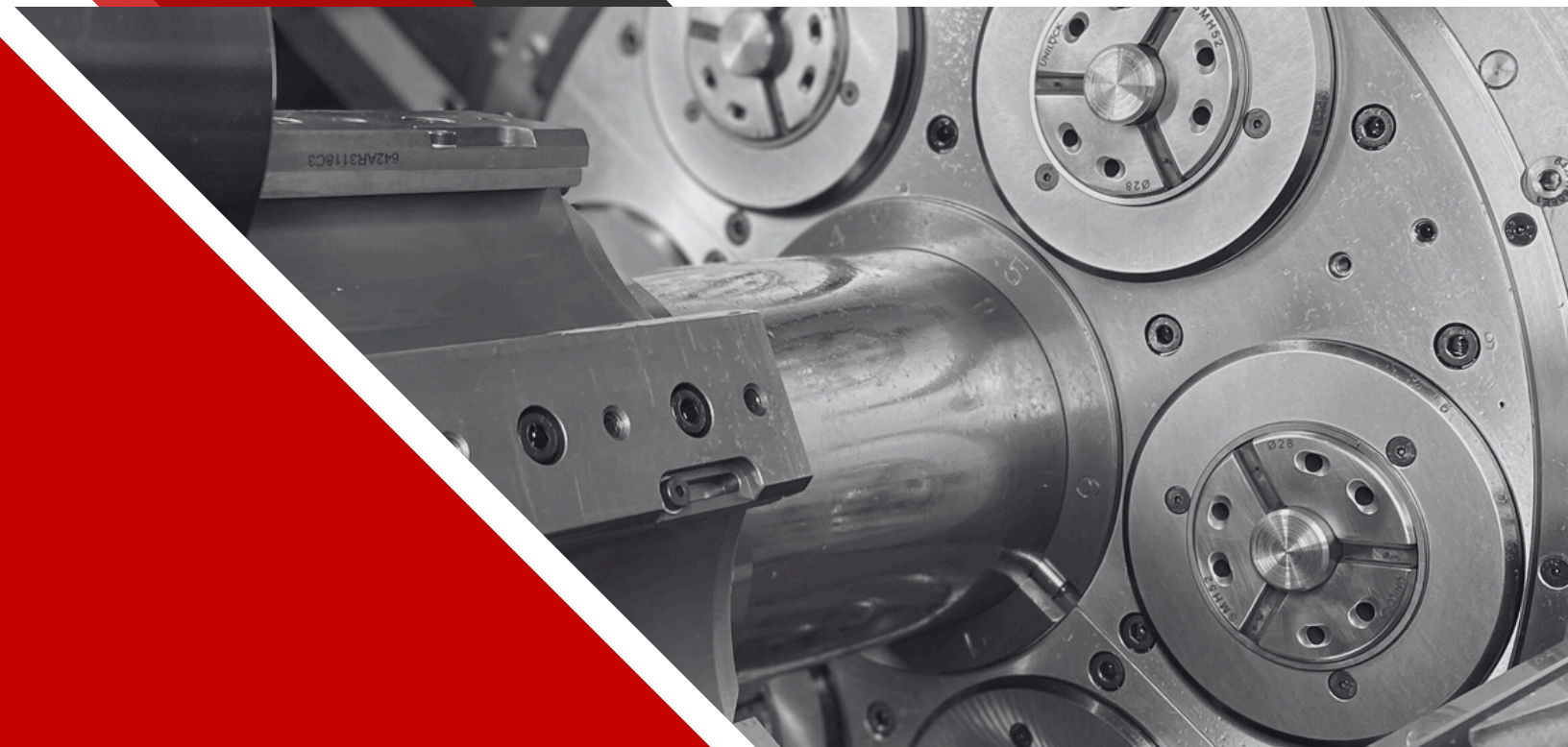

**GILDEMEISTER**

GM16

**TAJMAC-FRANCE**

# SOMMAIRE

<b>Pièces détachées</b>	<b>Page</b>
Cames et pincés	3
Système de serrage	4
Tube d'avance / Tube de serrage	5
Système de serrage	6
Axes et galets	7
Croix de malte / Embayages / Butée de barre	8
Broche de poussée / Crémaillère de coulisse	9
Arbre à cames	10
Leviers de coulisses	11
Commandes axiale	12-13
<b>Appareillages</b>	<b>Page</b>
Portes-outils	14
Broche frontale tournante	15
Porte-pincés	16
Groupe de taraudage	17
Dispositif broche de taraudage ou filière	18
Broche de reprise	19
Dispositif de frein pick-up	20
Appareil à brocher / à fraiser en bout	21
Appareillages / Pincés	22-23

# PIÈCES DÉTACHÉES

## Cames et pinces

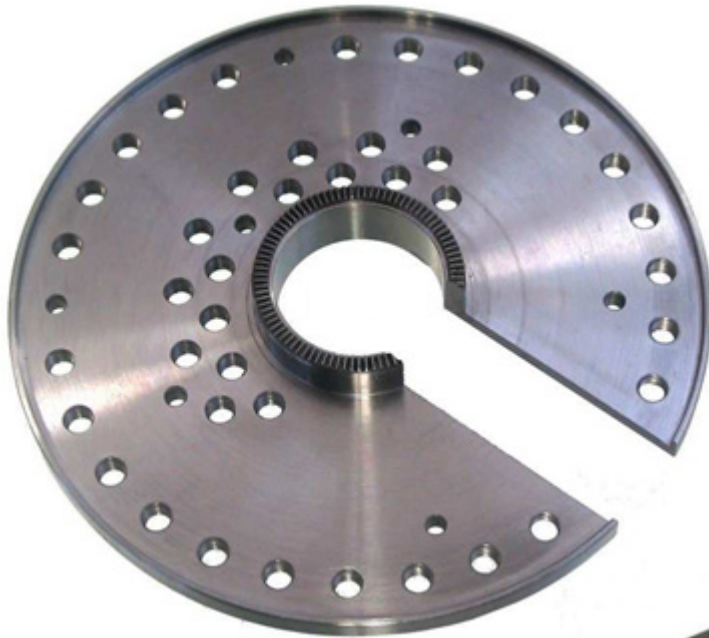

53.30.126



Cames



Q0001870  
Pince de pick-up



9628E  
Pince d'avance



9023E  
Pince de serrage

# Système de serrage



53.01.387



53.01.163



53.01.386



53.01.382



53.01.384



53.01.346



53.01.388

01.01.405



01.33.553



53.01.389

Ancien mécanisme de serrage



53.01.332



53.01.336

53.01.333



53.01.335



53.01.334



# Tube d'avance / Tube de serrage

53.01.234 machine standard  
53.01.279 machine d'arrêtage de broche

53.01.323 machine standard  
53.01.331 machine d'arrêtage de broche



53.01.236

9628E  
Pince d'avance



53.01.170

9023E  
Pince de serrage

# Systeme de serrage



53.01.106

# Axes et galets



53.01.361



53.02.126



53.05.124



53.02.167



53.02.131



53.05.113



53.12.121



53.05.156



01.27.025

53.26.126 L=38.5mm



53.26.108



05.03.010



01.06.606



53.03.130



53.03.130



53.26.172 L=51.5mm



01.06.615



53.03.129

# Croix de malte

## Nouvelle version



## Ancienne version



# Embrayages



# Butée de barre





53.22.005

Bielle de poussée avec compensation élastique

## Broche de poussée

53.22.108



53.07.243 pos.1-2  
 53.07.244 pos. 3  
 53.07.247 pos.3  
 53.07.247 pos.6  
 53.07.353 pos.6  
 53.07.320 pos.4-5

## Crémaillère de coulisse

Patin



53.04.175



53.26.156 pos.1  
 53.26.157 pos.2  
 53.26.158 pos.3  
 53.26.159 pos.4  
 53.26.160 pos.5  
 53.26161 pos.6



531018

531018

Option :  
 Rapport de pignons pour le perçage et le forage à grande vitesse



53.12.128

# Arbre à cames

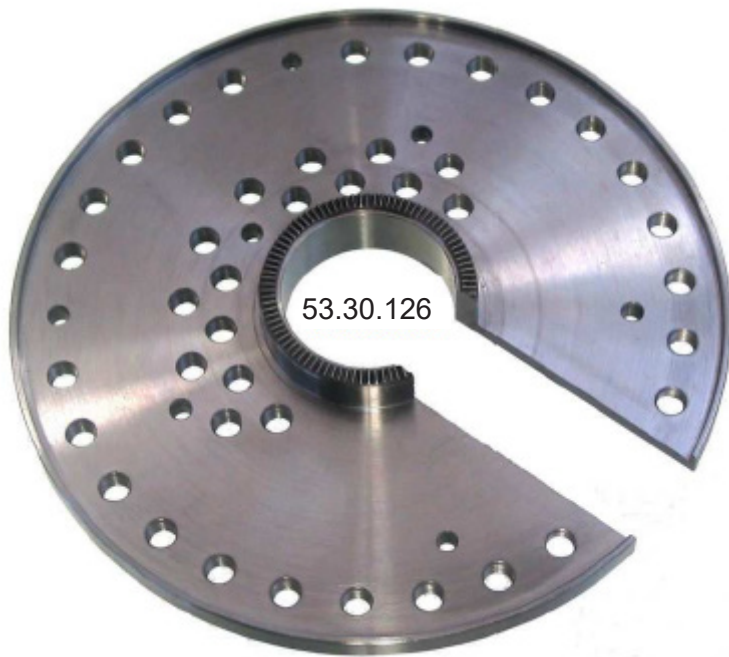

53.09.146



# Leviers de coulisses

53.26.174	pos.2-3-4	chariot croisé
53.26.173	pos.1-5-6	chariot croisé
53.22.138	pos.2-3-4	broches et coulisses axiales
53.22.137	pos.1-5-6	broches et coulisses axiales

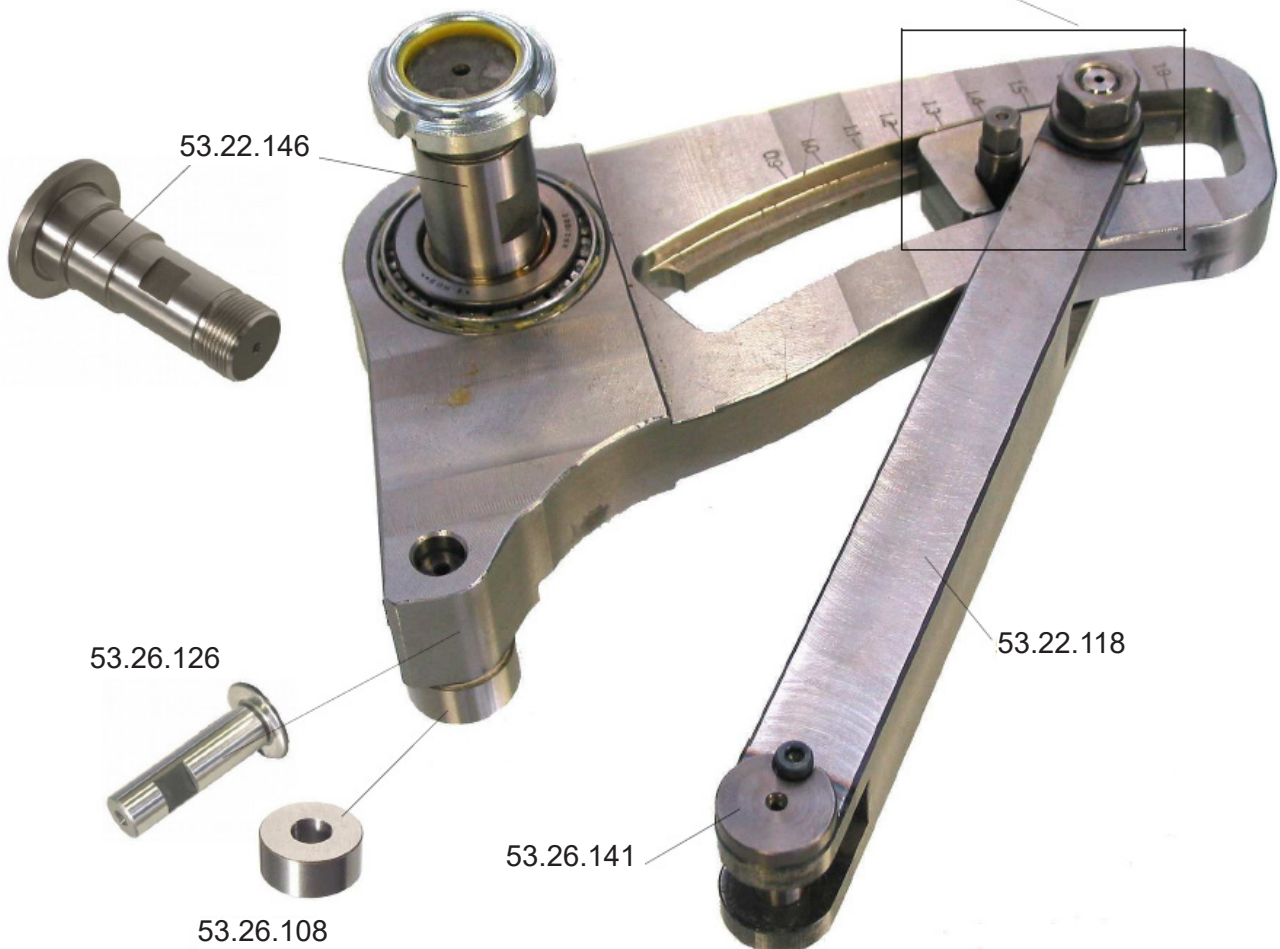
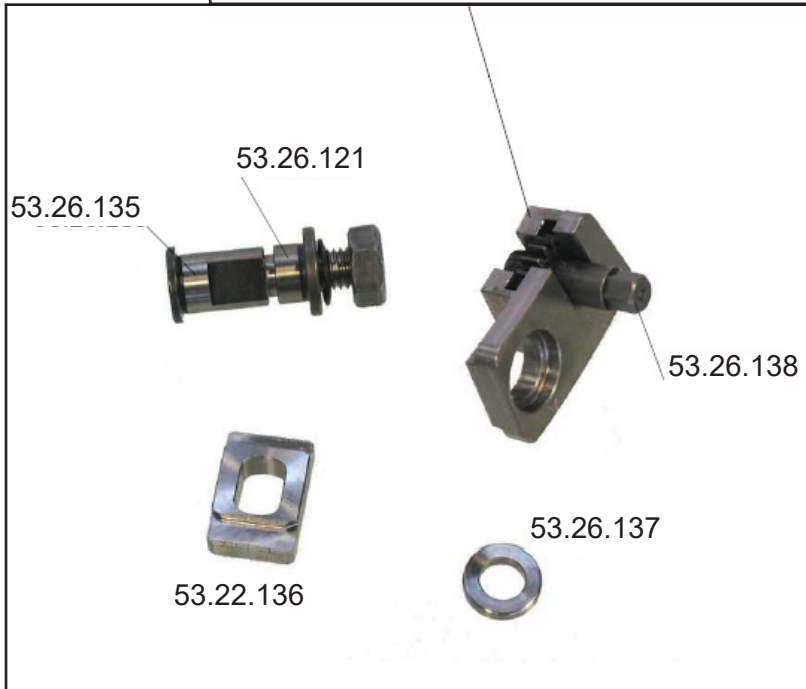

# Commandes axiales

- 5321009 - Set de poussée pour glissière axiale pos.1
- 5321010 - Set de poussée pour glissière axiale pos.2
- 5321011 - Set de poussée pour glissière axiale pos.3
- 5321012 - Set de poussée pour glissière axiale pos.4

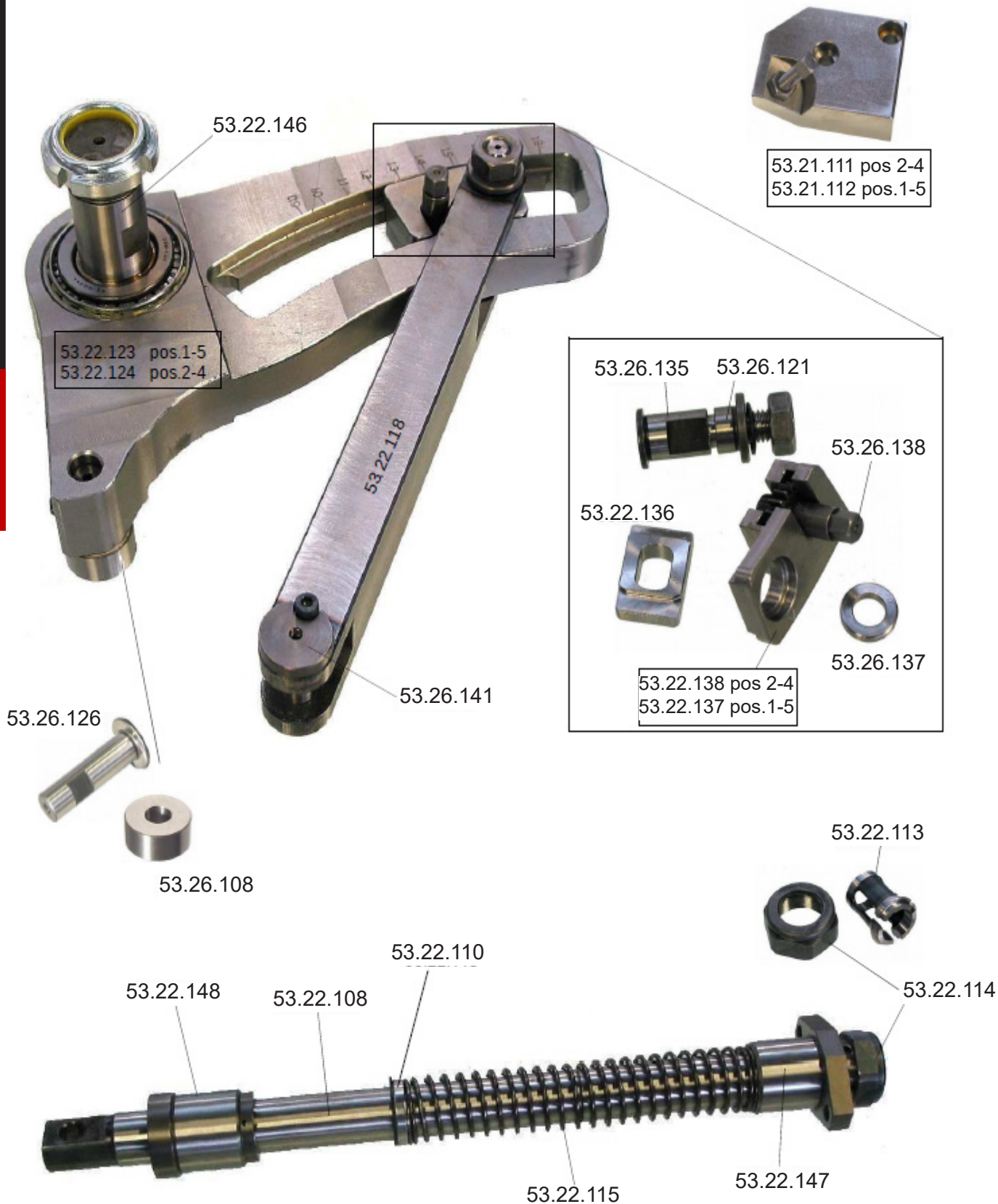

# Commandes axiales (suite)

- 5321009 - Commande de poussée pour glissière axiale pos.1
- 5321010 - Commande de poussée pour glissière axiale pos.2
- 5321011 - Commande de poussée pour glissière axiale pos.3
- 5321012 - Commande de poussée pour glissière axiale pos.4

- 53.21.118 pos.1
- 53.21.121 pos.2
- 53.21.124 pos.4
- 53.21.127 pos.5

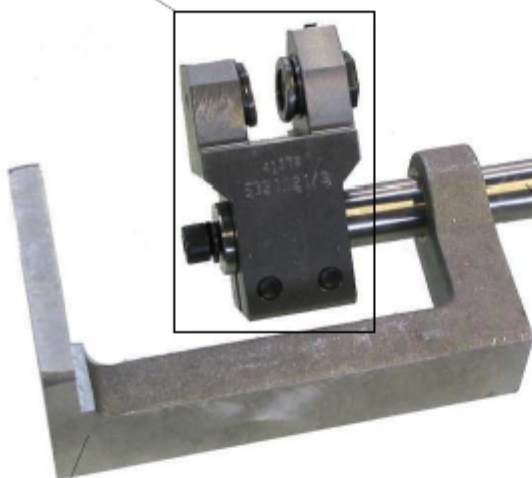
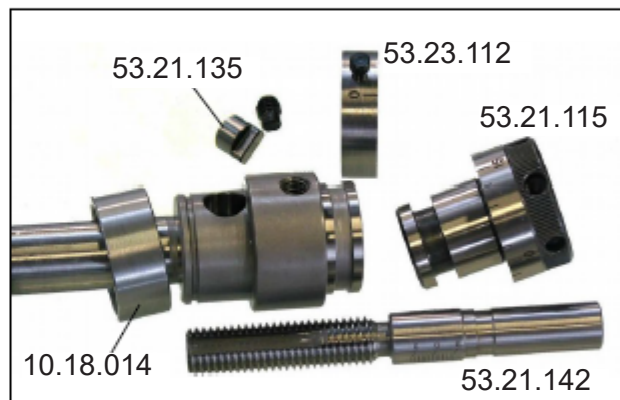

- 53.21.117 pos.1
- 53.21.119 pos.2
- 53.21.122 pos.4
- 53.21.125 pos.5



# APPAREILLAGES

## Portes-outils



5334006  
06050200  
porte-outils à barreau 12x12



5334019  
06052600  
Tourelle pos.1-2-3-5-5



5334010  
06050800  
Tourelle porte-outil  
pos.6



5334009  
06052700  
Porte-outil de coupe pos.6



5334027  
30161600  
Porte-outil de reprise  
pos.6



5334028  
Porte-outil de reprise  
pos.3

# Broche frontale tournante

53.23.052

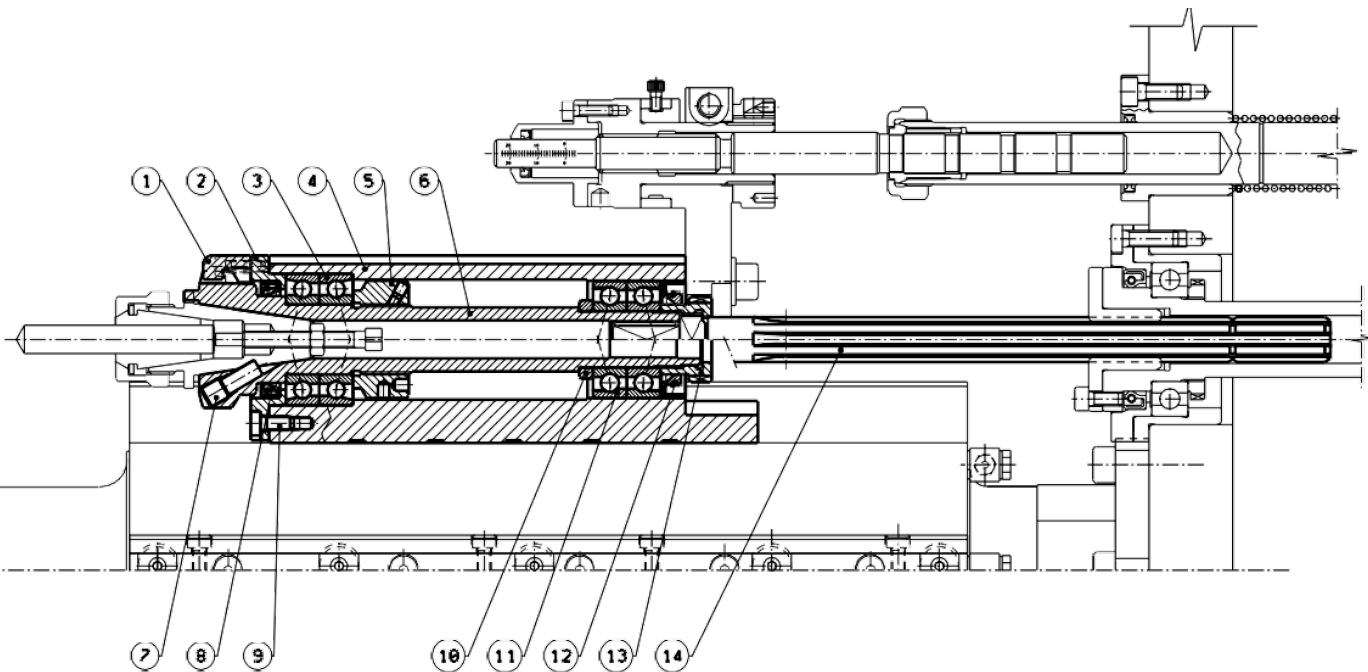

# Broche frontale tournante avec arrosage HP au centre

53.23.008

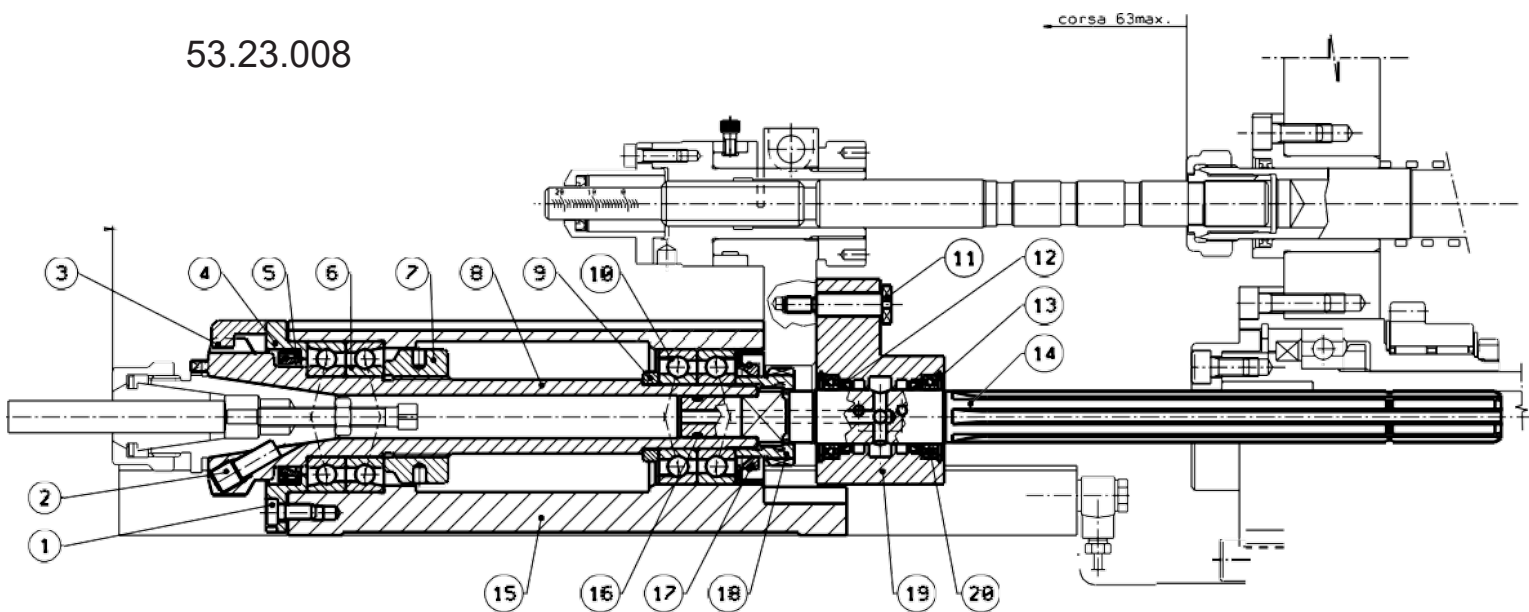

# Porte-pinces



5323011  
ISO25 - ESX32



5323010  
ISO25 - ESX25



5323012  
ISO25 - ESX20



Porte-pinces spéciaux sur demande

# Groupe de taraudage

53.25.001

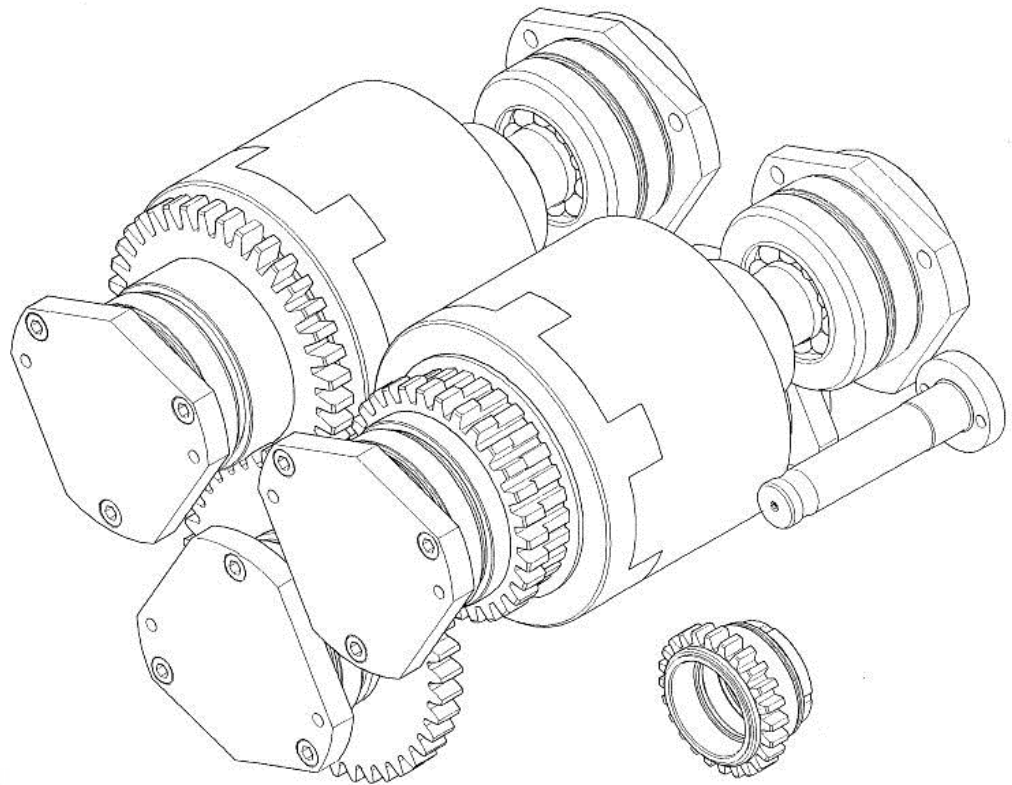

# Dispositif broche de taraudage ou filière



53.43.001

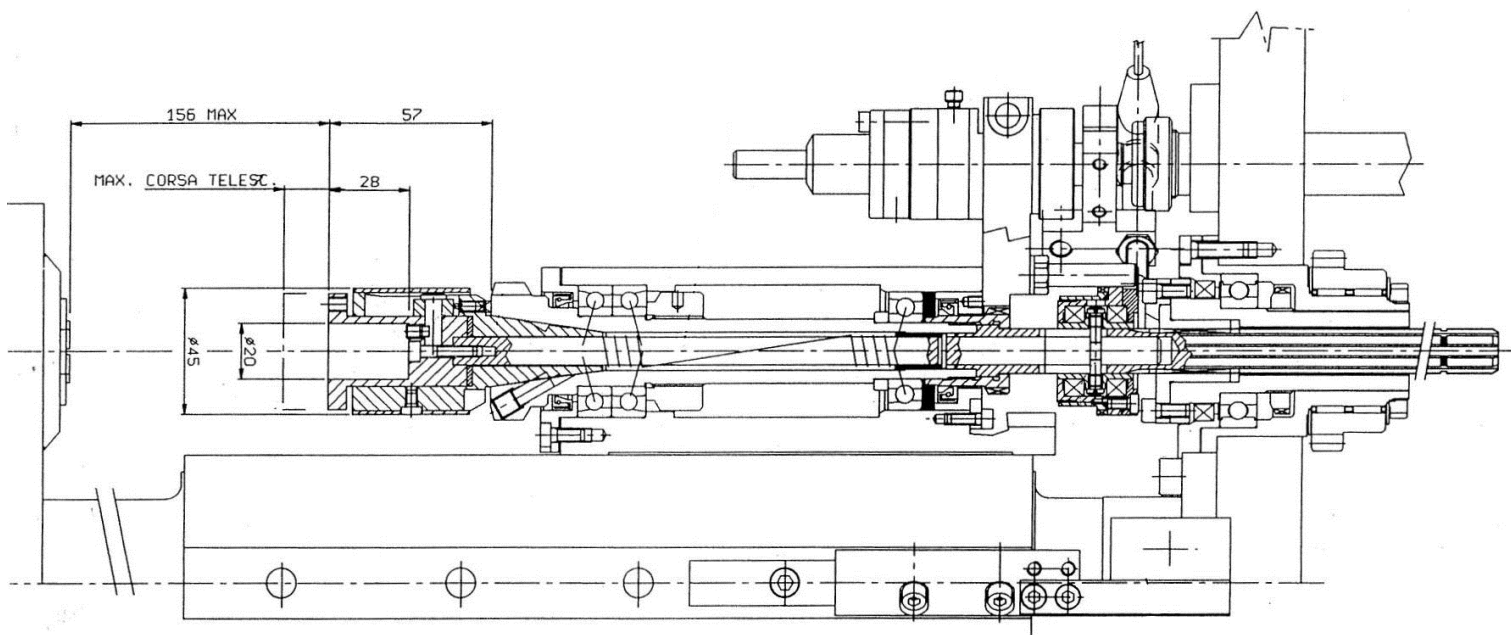

## Broche de reprise hydraulique double-effet pos.6



53.58.004

Cette broche de reprise est la dernière version avec serrage et desserrage de la pince hydraulique. Elle est synchronisée avec la broche principale avec la même vitesse de rotation pour la prise de pièce. Plus facile d'utilisation, le réglage du serrage se fait par le réglage de la pression hydraulique.

## Broche de reprise pos. 6 ancienne version simple effet



Cette broche de reprise est la première version avec seulement l'ouverture de pince hydraulique. Pour le serrage, elle est équipée de rondelles bellevilles à l'intérieur. Pour changer la force de serrage, il faut démonter le pick-up et échanger la rondelle d'épaisseur suivant les caractéristiques techniques pour augmenter ou réduire la force du serrage.

# Dispositif de frein pick-up pos.6

53.58.004

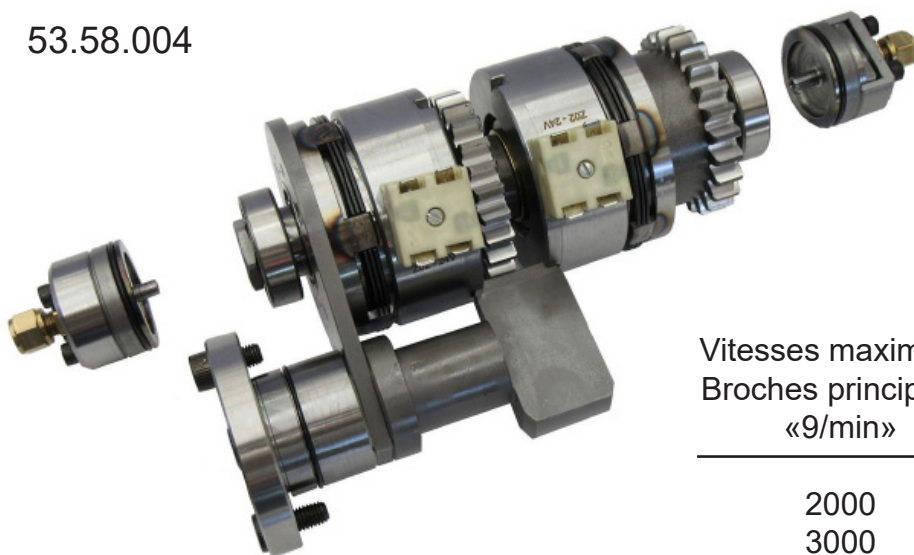

Vitesses maximales Broches principales «9/min»	Temps minimal de production «sec.»
2000	1.5
3000	2
4000	3
5000	4

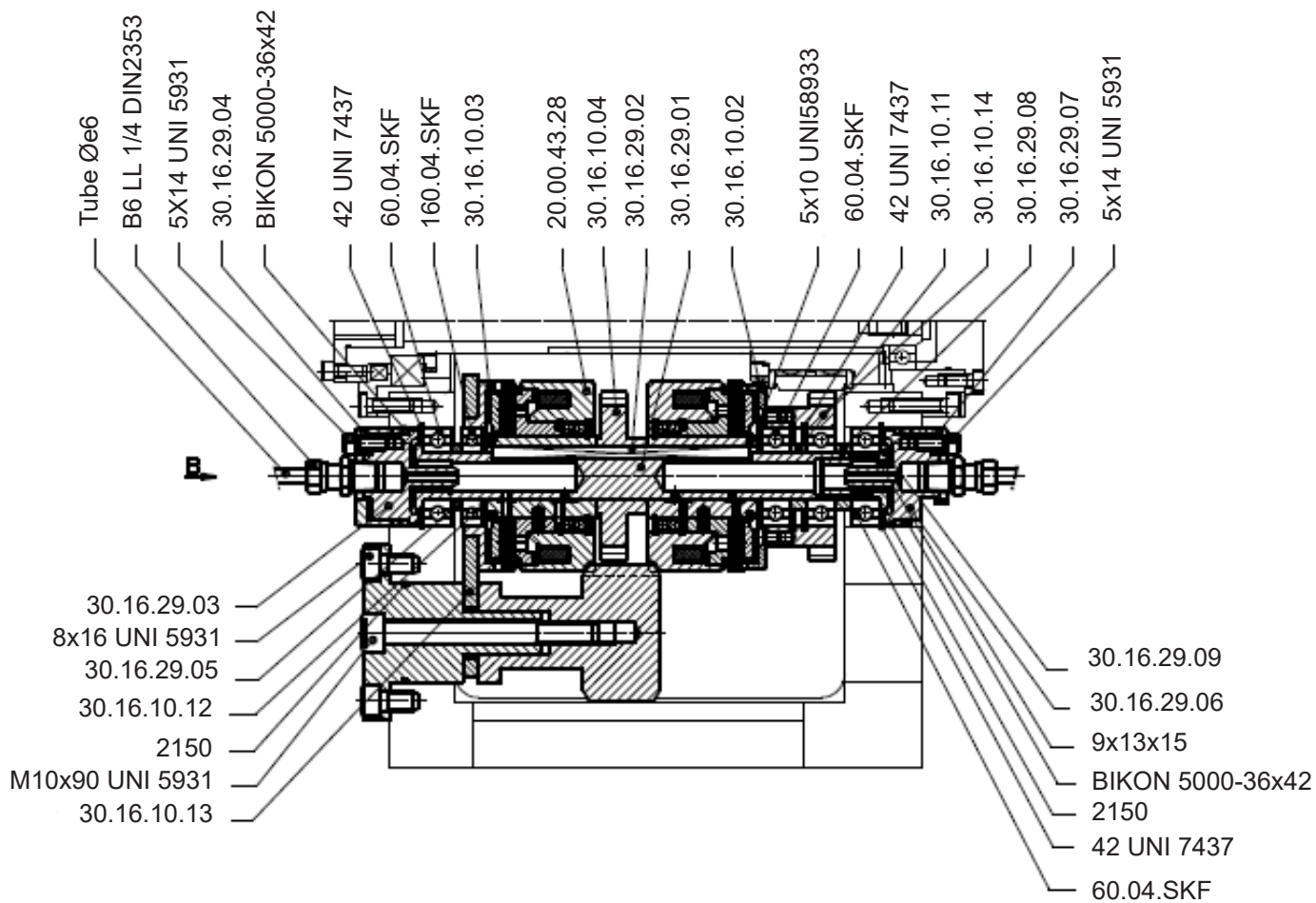

# Appareil à brocher



53.46.001

# Appareil a fraiser en bout



53.55.001

## Caractéristiques techniques :

- Positions de montage : Toutes
- Vitesses maximales de la broche : 5000 rpm
- Distance maximale entre la pince et le fraisage : 99 mm
- Course maximale : 35 mm
- Diamètre maximal de fraisage : 63 mm
- Diamètre maximal : 18 mm
- Rapport de fraisage : 0.267

# Votre partenaire pour l'équipement des tours automatiques



Disposant d'une grande expérience et moyens techniques importants, Tajmac-France vous propose la fourniture des appareillages, la révision partielle, la reconstruction complète de vos tours Gildemeister, ainsi que l'assistance sur site.

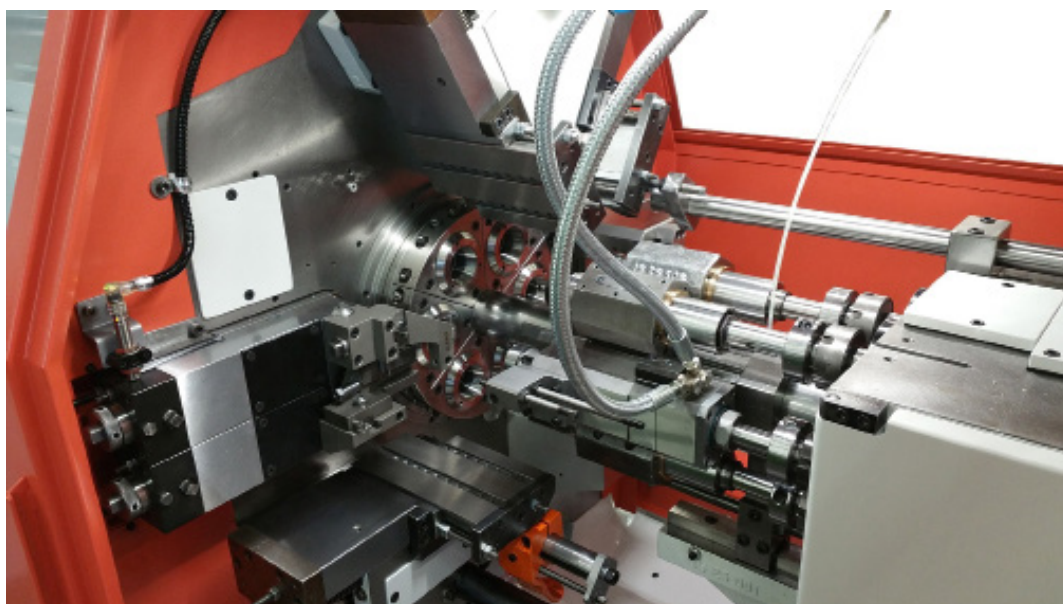

# Votre partenaire pour l'équipement des tours automatiques

- Appareillages IMG, SACO pour les tours GILDEMEISTER, WICKMAN, MORI-SAY, SCHÜTTE et TORNOS.

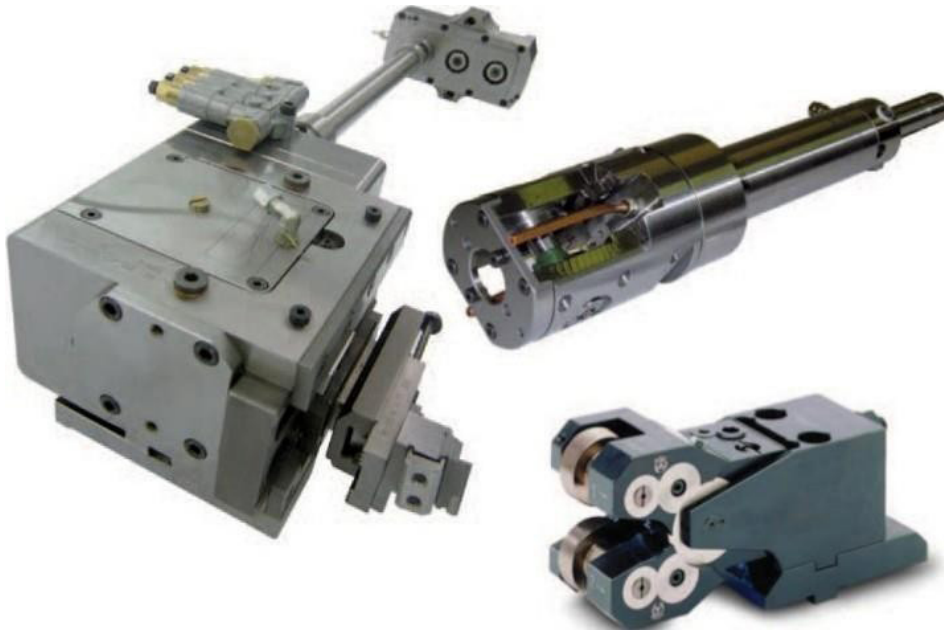

- Pincés de serrage, pincés d'avance, pincés pick-up pneumatiques / hydrauliques pour les tours multibroches GILDEMEISTER et multibroches autres marques, pincés embarreurs.





# TAJMAC – FRANCE



85 Rue Marie Curie  
ZAC des Grands Bois  
74130 VOUGY

Tel. (+33)4 50 34 00 41  
Fax. (+33)4 50 34 04 43

[www.tajmac-france.com](http://www.tajmac-france.com)  
[info@tajmac-france.com](mailto:info@tajmac-france.com)

