



PARTS LIST

AND

MAINTENANCE MANUAL

FOR

WICKMAN 1" 6-SPINDLE

WICKMAN 30MM 6-SPINDLE

BAR AUTOMATIC LATHES

IMPORTANT

The designs of all items shown in this publication are the property of Wickman Coventry Limited and are subject to copyright.

Our designs are continuously being developed and we reserve the right to incorporate modifications when necessary and without notice.

Whilst every effort has been made to ensure the accuracy of information herein, Wickman Coventry Limited do not accept liability for omissions and errors.

In all communications please quote the NUMBER of the machine as well as the size. This is most important.

PREFACE

This Manual provides the basic information and instructions that are necessary for the maintenance/servicing of the Wickman 1"-6 and 30mm-6 Spindle Bar Automatic Lathes with Relay Logic Control Equipment.

The contents will familiarize the reader with the machine construction specifications, installation procedure, safety at work and all the relevant aspects of the machine.

The manual should be read thoroughly. It will enable the Engineer to gain the knowledge required for the correct and efficient servicing of the machine.

An Operator's Handbook is also available for the 1"-6 and the 30mm-6 machines.

HEALTH AND SAFETY

Health and Safety at Work Act, 1974 - U.K. users only.

In accordance with the requirements of the Health and Safety at Work Act 1974, this manual embodies the necessary information to ensure that the machine tool can be maintained properly and with safety. It should be clearly understood that the engineer must be properly trained, have the required skills and be authorised to maintain the machine.

If it should arise that the person authorised to maintain the machine is undergoing training, he must be under the close supervision of another skilled and authorised person.

Adequate information is provided to enable the machine to be serviced and maintained in a satisfactory condition by engineers & electricians who have the necessary skills and authority. We recommend that a 'Permit to Work' system as detailed in BS5304; 1988 entitled "Safety of Machinery", should be operated.

HEALTH AND SAFETY (Continued)

It is important that the various statutory regulations which are applicable, eg, 'The Protection of Eyes Regulations' are complied with.

Operating Discipline

- (I) A clean, neat and well ordered machine and working area is the first essential of safety at work.
- (II) All guards, cover plates, cabinet doors and the tooling area guards must be in place or closed before any production run commences.
- (III) Never leave articles lying on any working surface where there is a danger that they may be dislodged by: any moving part of the machine, vibration, etc.
- (IV) Never wear rings, watches, neck-ties or loose-sleeved clothing when working on the machine.
- (V) Never operate the machine in excess of its rated capacity.
- (VI) Know where the EMERGENCY STOP BUTTON is.
- (VII) Never reach across a moving or rotating part of the machine
- (VIII) Never enter the tooling area or any other working part of the machine when the machine is running on production.
- (IX) When tool setting, changing tools or making adjustments, never enter the tooling area until the machine has been shut down.
- (X) When carrying out maintenance work, never enter any part of the machine, either mechanical or electrical, until the machine has been shut down and the isolator on the electrical control panel is in its "off" position, disconnecting the power supply.
- (XI) When working with lubrication oils and cutting oils of the soluble and straight cutting oil types, cleanliness is essential. Precautions must be taken to avoid all unnecessary contact with oil by ensuring that the machine's protective devices against coolant and oil spray are correctly closed and that protective clothing is worn. Never wear oil soaked clothes or place oily rags or tooling in the pockets of wearing apparel. Always wash oil from the body as soon as possible after contamination.

The Safe Operation Of Work Holding Devices

Collet equipment and collet operating mechanisms must always be kept in first class condition, in order to ensure that the bar is securely gripped to withstand all the applied cutting forces. Tooling area guards must always be closed when the machine is in the "run" condition.

MACHINE SIZE / MODEL RANGE

WICKMAN 1"-6 SPINDLE BAR AUTOMATIC LATHE *

WICKMAN 1"-6S SPINDLE BAR AUTOMATIC LATHE WITH SPINDLE STOPPING *

WICKMAN 1"-6DBF SPINDLE BAR AUTOMATIC LATHE WITH DOUBLE BAR FEED *

WICKMAN 1"-6LBF SPINDLE BAR AUTOMATIC LATHE WITH LONG BAR FEED *

WICKMAN 30mm-6 SPINDLE BAR AUTOMATIC LATHE *

WICKMAN 30mm-6S SPINDLE BAR AUTOMATIC LATHE WITH SPINDLE STOPPING *

This Manual applies only to the Machines marked *, above.

MACHINE SERIAL / INSPECTION NUMBER

In the event that queries arise with regard to the maintenance of the machine, it is important to note the following details which would need to be given to Wickman Bennett in all correspondence, ie:

Machine Inspection/Serial number, Machine size and Model.

The machine Inspection/Serial Number must always be quoted and is stamped on the machined-rim of the tray of the machine, on the left hand side, close to the Operators position. Additionally the number is also engraved on the machine Manufacturing Plate (WSP500) which is affixed to the main drive housing casting at the rear of the machine.

Reference to this number will facilitate any service that may be required.

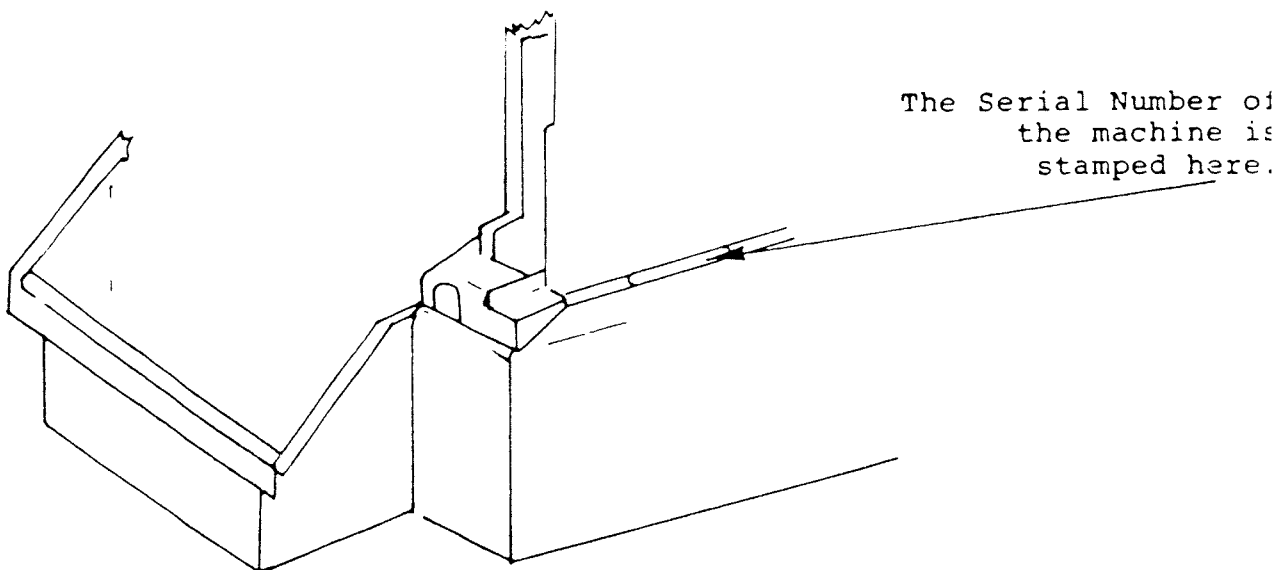

DETAILED CONTENTS LIST

PAGE

SECTION ONE - SPECIFICATIONS

7

- 1.1 Machine Specifications
- 1.2 Electrical Specifications

SECTION TWO - INSTALLATION

13

- 2.1 Lifting the Machine
- 2.2 Siting and Foundations

SECTION THREE - LUBRICATION

17

- 3.1 General Description
- 3.2 Summary of Lubricants
- 3.3 Lubrication Chart 1"-6, 30mm-6

SECTION FOUR - PREVENTATIVE MAINTENANCE SCHEDULE

23

- 4.1 1000 Hour Procedures
- 4.2 2000 Hour Procedures
- 4.3 4000 Hour Procedures
- 4.4 12000 Hour Procedures

SECTION FIVE - MACHINE CONSTRUCTION & MAINTENANCE PROCEDURES

29

- 5.1 Main Frame
- 5.2 Main Drive
- 5.3 Feed Gearing
- 5.4 The Main Camshaft
- 5.5 Upper Camshaft
- 5.6 The Spindle Drum
- 5.7 Drum Locking
- 5.8 Work Spindles
- 5.9 Collet and Bar Feed Operation
- 5.10 Bar Stop
- 5.11 Centre Tool Block & Longitudinal Slides

DETAILED CONTENTS LIST

PAGE

- 5.12 Cross Slides Operation
- 5.13 Lubrication
- 5.14 Coolant
- 5.15 Swarf Conveyor
- 5.16 Feed Trip & Automatic Stop Mechanisms
- 5.17 Double Bar Feed Machine
- 5.18 Spindle Stopping Machine
- 5.19 Special Feed and Speed Chart

- 5.20 Special Capacity Charts
- 5.21 Dismantling
- 5.22 Stock Carriage

SECTION SIX - PARTS LISTS AND GENERAL ARRANGEMENTS

57

SECTION ONE - SPECIFICATIONS

1.1 Machine Specifications 1"-6 , 1"-6DBF & 30mm-6

Description	Unit	Specification	Remarks
<u>CAPACITY</u>			
		1"-6 30mm-6	
Bar capacity:			
Round	mm	25.4 30.0	Solid Collet
Hexagon A/flats	mm	22.0 26.0	Solid Collet
Square A/flats	mm	18.0 21.2	Solid Collet
Round	mm	25.4 30.0	Master Collet/Pads
Hexagon A/flats	mm	22.0 26.0	Master Collet/Pads
Square A/flats	mm	18.0 21.2	Master Collet/Pads
Bar feed stroke:	mm	101.6	
Approach strokes: Centre block and Independent Slide	mm	50.8	
Feed strokes:			
Main Tool block	mm	0 to 63.5	
Independent slides	mm	0 to 63.5	
Cross slides:			
Stn.1	mm	0 to 12.7	
Stn.2	mm	0 to 12.7	
Stn.3	mm	0.8 to 12.7	
Stn.4	mm	0 to 12.7	
Stn.5	mm	0 to 12.7	
Stn.6	mm	0.8 to 12.7	
Spindle speed range:	r/min	268 to 4014	
Number of steps:		28	
Cycle time range:	Secs	1.9 to 123	
Idle time	Secs	1.04	
Main Motor Power	kW	15.28	
<u>GENERAL</u>			
Required Floor Space:	mm	1257 x 3346	O/all length excludes the stock carriage.
	mm	1257 x 6254	O/all length includes the stock carriage.
Shipping Weight (Net)	kg	6313	

1.1 Machine Specifications 1"-6 Spindle Stopping Machine

Description	Unit	Specification	Remarks
<u>CAPACITY</u>			
Bar capacity:			
Round	mm	25.4	Solid Collet
Hexagon A/flats	mm	22.0	Solid Collet
Square A/flats	mm	18.0	Solid Collet
Round	mm	25.4	Master Collet/Pads
Hexagon A/flats	mm	22.0	Master Collet/Pads
Square A/flats	mm	18.0	Master Collet/Pads
Bar feed stroke:	mm	127.0	
Approach strokes: Centre block and Independent Slides	mm	63.5	
Feed strokes:			
Centre block	mm	63.5	
Independent slides	mm	63.5	
Cross slides:			
Stn.1	mm	0 to 12.7	
Stn.2	mm	0 to 12.7	
Stn.3	mm	0.8 to 12.7	
Stn.4	mm	0 to 12.7	
Stn.5	mm	0 to 12.7	
Stn.6	mm	0.8 to 12.7	
Spindle speed range:	r/min	220 to 2694	
Number of steps:		24	
Cycle time range:	Secs	2.4 to 129	
Idle time	Secs	1.3	
Main Motor Power	kW	15.28	
<u>GENERAL</u>			
Required Floor Space:	mm	1257 x 3346	O/all length excludes the stock carriage.
	mm	1257 x 6254	O/all length includes the stock carriage.
Shipping Weight (Net)	kg	6313	

1.1 Machine Specifications 1"-6 Long Bar Feed Machine

Description	Unit	Specification	Remarks
<u>CAPACITY</u>			
Bar capacity:			
Round	mm	25.4	Solid Collet
Hexagon A/flats	mm	22.0	Solid Collet
Square A/flats	mm	18.0	Solid Collet
Round	mm	25.4	Master Collet/Pads
Hexagon A/flats	mm	22.0	Master Collet/Pads
Square A/flats	mm	18.0	Master Collet/Pads
Bar feed stroke:	mm	12 to 203	
Approach strokes:			
Centre block and	mm	63.5	Standard Cams
Independent Slides	mm	50.8	Special Cam
Feed strokes:			
Centre block	mm	63.5	
Independent slides	mm	63.5	
Cross slides:			
Stn.1	mm	0 to 12.7	
Stn.2	mm	0 to 12.7	
Stn.3	mm	0.8 to 12.7	
Stn.4	mm	0 to 12.7	
Stn.5	mm	0 to 12.7	
Stn.6	mm	0.8 to 12.7	
Spindle speed range:	r/min	247 to 3030	
Number of steps:		24	
Cycle time range:	Secs	2.4 to 129	
Idle time	Secs	1.92	
Main Motor Power	kW	15.28	
<u>GENERAL</u>			
Required Floor Space:	mm	1257 x 3346	O/all length excludes the stock carriage.
	mm	1257 x 6254	O/all length includes the stock carriage.
Shipping Weight (Net)	kg	6313	

1.1 Machine Specifications - General

Description	Unit	Specification	Remarks
GENERAL			
Coolant Tank Capacity	Litres	455	
Jacking Screws	4 off		
Service Tool Kit	1 off		Toolbox, spanners, wrenches, tool height setting gauge
LUBRICATION			
Main Spindle Bearings			See Section on Lubrication
Main Drive Housing			Splash lubrication
All Electric Motors			Sealed for life - maintenance free

1.2 Electrical Specifications

Description	Unit	Specification	Remarks
MAINS SUPPLY CONDITIONS:			
Line Voltage	Volts	220 to 575	Customer to advise.
Allowable variation in V	%	+/-10	About nominal
Frequency	Hz	50 or 60	Customer to advise.
Allowable variation in Hz	%	+/-1	About nominal
Total power requirements	kW	Variable	Dependent upon Customer's Mains Supply
MAIN SPINDLE MOTOR:			
Foot mounted, totally enclosed, fan cooled	kW	15.28	Standard
	r/min	1450	At 50Hz
	r/min	1750	At 60Hz
SWARF CONVEYOR MOTOR:			
Flange Mounted, totally enclosed fan cooled motor	kW	0.18	Applicable to Wickman Bennett standard screw type swarf con- veyor.

Power to the equipment is supplied through the Electrical Control Enclosure.

Maintenance Notes

SECTION TWO - INSTALLATION

2.1 Installation and Lifting

In planning the siting of a machine, consideration should be given to the space required for chip removal, bar loading and servicing, ie, centre-shaft removal. Dimensions of suitable lifting bars for use with a crane are shown on Drawing No.100Y50E, fig.2.1. They must be used with the lifting frame shown on Drawing No.100Y579, fig.2.2. The lifting bars are fed through the holes provided in the machine tray, collars are then assembled & clamped to the bars in order to prevent the ropes used with the lifting frame from slipping. Care must be taken to ensure that the lifting frame ropes do not damage the machine during lifting. Examine the position of the lifting frame with the tension on the ropes before the full weight of the machine is lifted.

Where a crane is not available, the machine may be moved by "wedge", truck or rollers and continuous machined surfaces are provided on the underside of the machine tray to facilitate the operation. If rollers are used, they must be longer than the machine tray width.

Careful handling of the machine will ensure accurate alignment.

2.2 Siting and Foundation

The machine should be installed on a level and stable foundation in order to ensure accurate alignment is maintained. A concrete base is recommended, it provides the most suitable foundation because of its stability and because it is less prone to distortion when laid down in adverse soil conditions.

The actual depth of concrete base must be determined to suit the prevailing soil conditions, which must be capable of supporting the machine, ancillary equipment, tooling and the concrete base itself. The soil should be consolidated with crushed rock, pebbles and stones.

2.3 Levelling the Machine and Sundry Requirements

With the machine in position on the factory floor, adjust its level using the jacking screws provided in the machine tray. It is recommended that steel plates be placed between the floor and the screws. Longitudinal and lateral alignment levels can be checked with a precision spirit level on the facings provided at both ends of the machine tray, see Drawing No. 100Y50E, fig.2.1. Wedges should be placed at the positions shown.

Foundation bolt holes are also provided for use where required, the bolts being embedded into the floor approximately 5ins (125mm).

Where not bolted-down, machines can be grouted or cemented by any shop approved method.

The stock carriage tube assembly (weight: 450lbs/205kg) should be lifted into position and made ready for joining to the machine.

When the machine has been laid down and levelled, the stock carriage and stand should be fitted, the stock tubes being correctly aligned with the machine spindles. A good alignment check is to view the collet openings through the stock tubes. Adjusting screws in the base of the stock carriage stand are provided for alignment purposes and it is recommended that a steel plate be placed beneath each levelling screw before the adjustment takes place. When correctly aligned, the stock carriage stand should be bolted down and grouted in position.

Fig.2.1 Foundation Drawing 100Y50E

1. 66" (1680mm) Over open doors
2. 150" (3810mm) Clearance for loading bars
3. 117.7/8" (2994mm) Stock carriage assembly
4. Wedges
5. Panel 0.8kW.
6. Level the machine with the screws provided. Use wedges where shown. Grout or bolt in position. Levelling surfaces shown thus *.
Machine should rest on concrete not less than 6" (152mm) thick.
7. 66" (1676mm) Swing of bar feed covers.
8. 53" (1350mm) Over guards
9. 44.7/16" (1129mm) Bolt Centres
10. 48.9/16" (1234mm) Over lips of tray.
11. Weights:
Machine including motor, panel and guards 13920 lbs (6313 kg).
Stock carriage and stand 452 lbs (205 kg).
Swarf conveyor 553 lbs (251 kg).
12. 2 Collars each end 6" (150mm) dia. Secured by set screws.
13. Holes for lifting bars
14. 1.1/4" (31.7mm) for 1" (25mm) bolts.
15. 4 Holding down bolts 3/4" (20mm) dia. Bolts, nuts and washers to be supplied by customer.
16. It is recommended that plates be fitted under the levelling screws. Plates to be supplied by customer.
17. Views of stock carriage base. Scale 1:10
18. Bolt plan of stock carriage stand.
19. Conveyor motor 0.25 kW.
20. Swarf conveyor. Optional
21. Lifting bar (suggested dimensions) 2 required. Customer to supply

Fig.2.1 Foundation Plan Drg.100Y50E

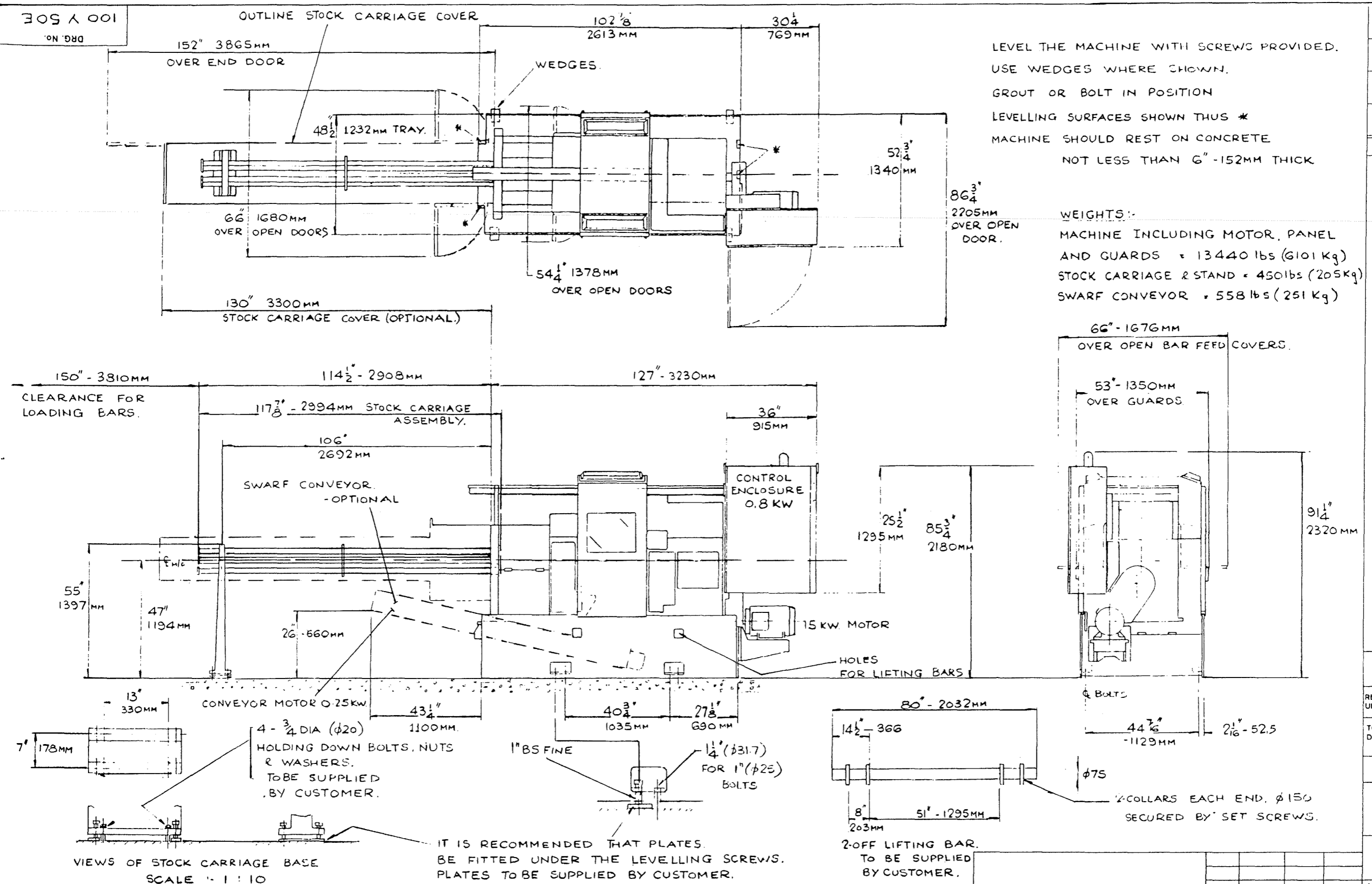

LEVEL THE MACHINE WITH SCREWS PROVIDED.
USE WEDGES WHERE SHOWN.
GROUT OR BOLT IN POSITION
LEVELLING SURFACES SHOWN THUS *
MACHINE SHOULD REST ON CONCRETE NOT LESS THAN 6" - 152MM THICK

WEIGHTS:-
MACHINE INCLUDING MOTOR, PANEL AND GUARDS = 13440 lbs (6101 kg)
STOCK CARRIAGE & STAND = 450 lbs (205 kg)
SWARF CONVEYOR = 558 lbs (251 kg)

FIRST USED ON
LAST USED ON
SUPERSEDES
SUPERSEDED BY
ALTERATIONS

'U' & 'B' LIMIT HOLES TO B.S. 184: 1941
REMOVE ALL SHARP CORNERS UNLESS OTHERWISE STATED
TOLERANCE ON MACHINING DIMENSIONS ± 0.01 UNLESS OTHERWISE STATED
AMERICAN PROJECTION
F - ROUGH MACHINE FF - FINISH MACHINE FFF - GRIND OR EQUIVALENT
RAW MATERIAL No.

WICKMAN BENNETT
MACHINE TOOL CO. LTD.
COVENTRY ENGLAND

COPYRIGHT © THIS DRAWING AND DESIGN IS THE PROPERTY OF WICKMAN BENNETT MACHINE TOOL CO. LTD., COVENTRY, ENGLAND. AND IS CONFIDENTIAL. IT MUST NOT BE LOANED, COPIED OR OTHERWISE COMMUNICATED TO A THIRD PARTY WITHOUT PERMISSION AND IS SUBJECT TO RECALL AT ANY TIME.

DESCRIPTION	FOUNDATION DRAWING.
SCALE:-	1:20
DRAWN	RW
CHECKED	FEB 88
TRACED	
TRACING CHECKED	
ARRGT.	
No. OFF	DRG. No.
SECTION	MACHINE

MARK DRG. No. AT #
DRG. No.
100 Y 50 E

100Y579
DRG. No.

LAST USED ON
SUPERSEDES
SUPERSEDED BY
ALTERATIONS

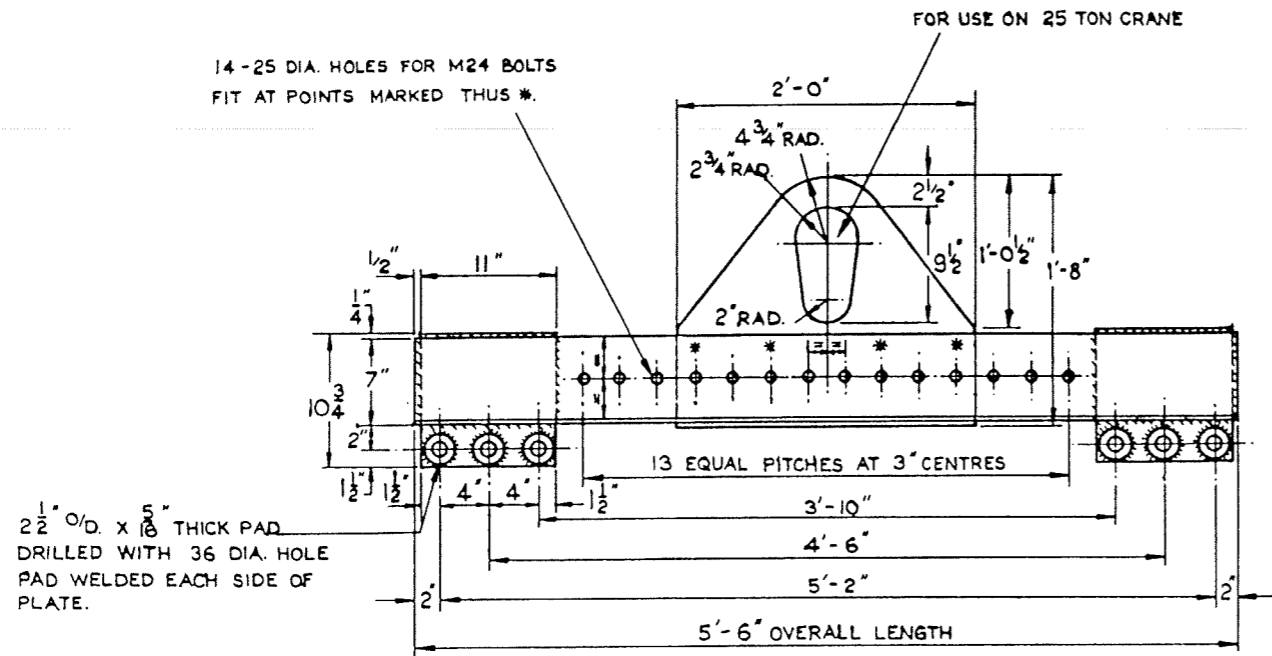

DETAIL OF LIFTING BEAM
ONE REQUIRED AS DRAWN
S.W.L. 10 TONS
APPROX. WEIGHT COMPLETE: 7 CWT.

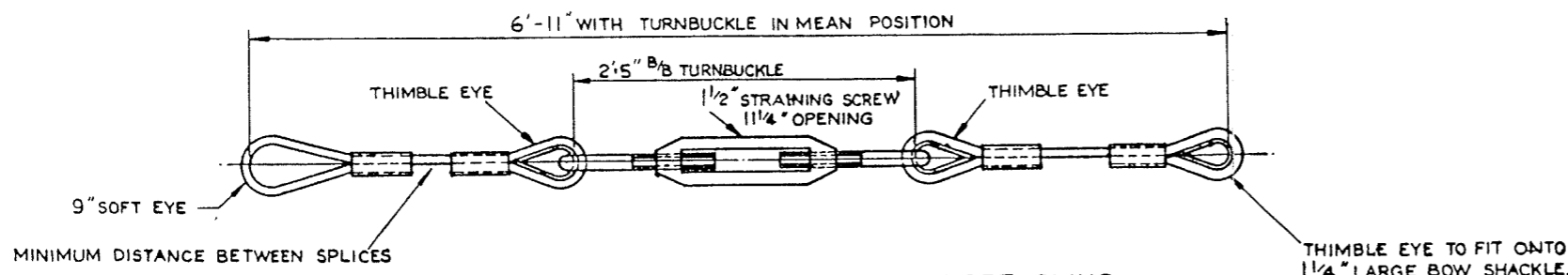
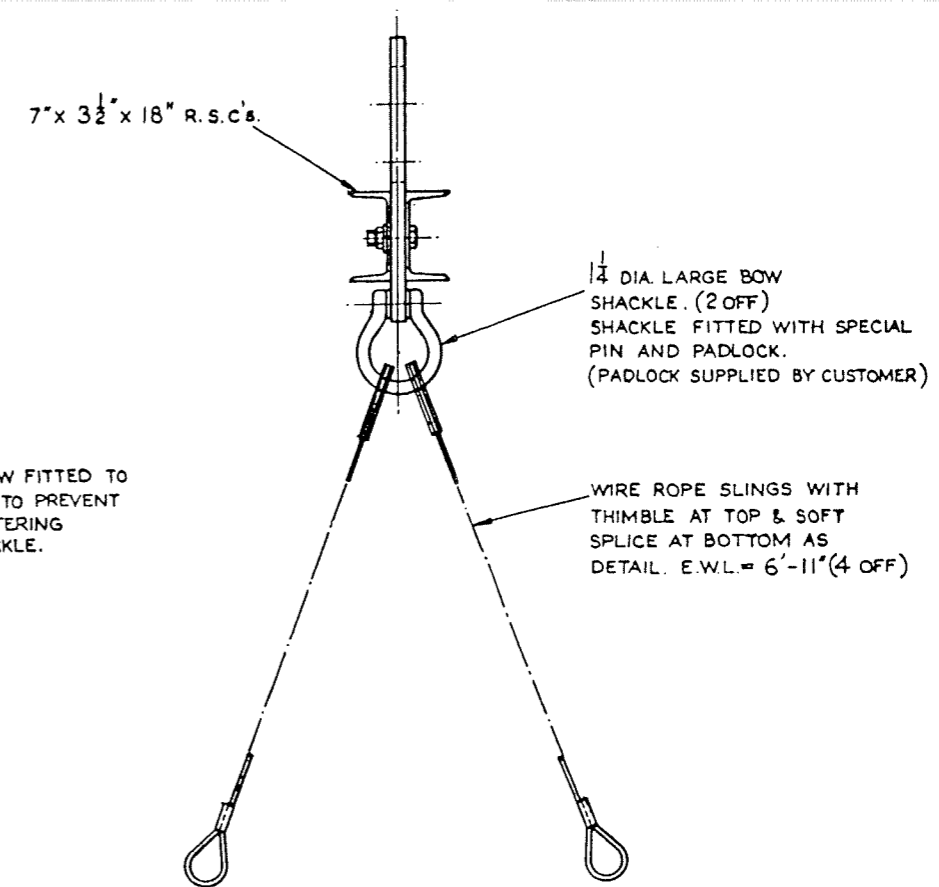
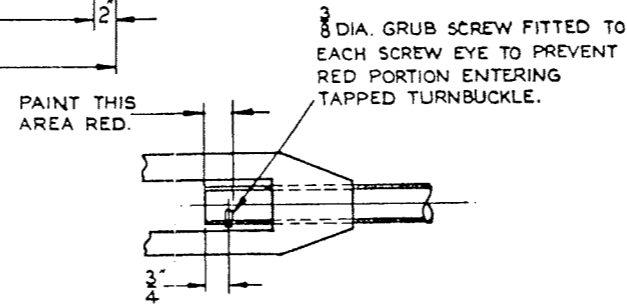

DETAIL OF 18MM. DIA. WIRE ROPE SLING
4 REQ'D. AS DRAWN

U' & 'B' LIMIT HOLES TO B.S. 144. 1941.

REMOVE ALL SHARP CORNERS UNLESS OTHERWISE STATED.

TOLERANCE ON MACHINING DIMENSIONS + 0.00 UNLESS OTHERWISE STATED.

AMERICAN PROJECTION

F = ROUGH MACHINE
FF = FINISH MACHINE
FFF = GRIND OR EQUIVALENT

RAW MATERIAL No.

CRANE AID SERVICES LTD. DRG. No. 22 - A9 - 2024C.

SCALE: 1 1/2" = 1 FOOT	DRAWN	7.12.78	MATERIAL				
	CHECKED						
	TRACED	D.E.L. 11.11.80					
	TRACING CHECKED						
No. OFF	ARR!	SECTION	MACHINE				

MARK DRG. No. AT ⊕

DRG. No.

100Y579

WICKMAN MACHINE TOOL MANUFACTURING CO. LTD.
COVENTRY — ENGLAND

DESCRIPTION

DETAIL OF 10 TON LIFTING BEAM

100Y579

SECTION THREE - LUBRICATION

3.1 General Description

The oil tank is situated in the tray of the machine in the front of the main drive housing, see fig.3.5, drg.168Z10B. Care must be taken to ensure that only lubricating oil is put into this tank. Use oil grade ISO 3498 CB68 or alternatives HL68 or HM68. The tank is filled through a filler/breather/strainer provided and accessible externally. When fitted, (optional extra) a low level float switch will shut down the machine if the oil falls to a level which would create a critical situation.

The lubricating pump is of the gear type and is chain driven from the constant speed pulley shaft. The pump is mounted in an eccentric bush for chain adjustment and is locked by a locknut.

The oil is drawn through a strainer with an adjacent foot valve to avoid priming. A relief valve is also fitted in the intake pipe to release pressure should the main motor be started running in the opposite direction. The oil is drawn through a strainer and pumped through a 'Purolator' filter to a relief valve set at maximum pressure. This does not normally require adjustment. The 'Purolator' knob should be turned daily and its element taken out and cleaned periodically. Part of the oil pumped through the 'Purolator' and the relief valve goes to the 'Micronic' filter situated on top of the machine. Part is bypassed before reaching this filter to another relief valve, set to give a pressure of approximately 20lbs/inch sq (1.4 kg/cm sq.) in the circuit from the 'Purolator'/relief valve, this pressure being displayed on a pressure gauge.

The oil which passes through the 'Micronic' filter feeds the spindles via the spindle sight feeds as well as all points feeding the drum housing, the upper cross slides and certain points on the collet and bar feed mechanisms. The 'Micronic' filter has a replacement element which must be changed periodically. A spare element is included with the equipment supplied with the machine. The spindle oil sight feeds are adjusted by the needle valves above each sight feed and should be set to give 10 to 20 drops of oil per minute. They should be observed frequently to see that the rate of feed is steady and in accordance with the instruction plate. The actual rate of feed should be adjusted according to the spindle speed, but should be kept on the generous side while the machine is new.

The oil which is bypassed before the 'Micronic' filter circulates to various needle valve headers and spray pipes arranged to feed points in the main drive housing. Oil is also fed to a drip tray above the longitudinal slides mechanism and is provided with drip pipes to feed all the important points in the mechanism.

The lubrication system is adjusted correctly before the machine is despatched but should be checked on installation and at regular intervals.

Concerning Lubrication:

- (a) Check the oil level in the tank, it must not fall below the level indicated.
- (b) Frequent checks of the spindle sight feeds are necessary; also check that the main drive oil is circulating.
- (c) Turn the 'Purolator' knob daily.
- (d) Micronic Filter: Remove top to replace filter element. See drawing 168Z10B.

3.2 Summary of Lubricants

Wickman Oil Grade	1	2	3	4	5
Applicat-ion	Light Spindle Oil	Air Line Lubricat-ion for Cold Climates	Air Line Lubricat-ion for Warm Climates	Centralised Lube. Air Line Lub'e Hyd. syst. Gen.Lub'e for Cold Climates	General Lubrication Centralised System for Warm Climates
B.P	Energol HL 40	Energol HL 50	Energol HL or HLP 65	Energol HLP 80	Energol HLP 100
CASTROL	Hyspin AWS 10	Hyspin AWS 22	Hyspin AWS 32	Hyspin AWS 46	Hyspin AWS 68
CENTURY	P79A	P313	PWLA	PWLB	PWLC
DUCKHAMS	Zircon 1	Zircon 3	Zircon 4	Zircon 5	Zircon 6
ESSO	Nuto H36	Nuto H40	Nuto H44	Nuto H48	Nuto H54
GULF	Harmony 34AW	Harmony 40AN	Harmony 43AW	Harmony 48AW	Harmony 54AW
MOBIL	Velocite oil No 6	Velocite oil No 10	DTE oil light or DTE 24	DTE oil med. or DTE 25	DTE oil heavy med. or DTE 26
PETROFINA	Cirkan 15	Hydran 21	Hydran 31	Hydran 31	Hydran 37
SHELL ISO VG NO	10	22	37	46	68
TEXACO	Spintex 60	Spintex 100	Rando HD.A	Rando HD.B	Rando HD.C
VAUGHAN	KSO 5L	KSO No.1	Evco Med. Hyd. or Hydrodrive HP 150	Evco Heavy Hyd. or Hydrodrive HP 200	Evco Extra Heavy Hyd.or Hydrodrive HP 300

Where alternative grade references are given it is recommended that the lighter grade (lower number) is used unless oil consumption is excessive.

For Slideways Grade 5 is suitable for use with oil-base coolants and Grade 7 for use with water-base coolants.

Wickman Oil Grade	6	7	Wickman Grease Grade	1	2
Application	Reduction Units (Swarf conveyor)	Slideways		GREASES	
B.P	Energol CS 300	Energol HP 20-C		Electric Motors	Spindle Nose Cap
CASTROL	Alpha 417	Magna BD		Ener Grease LS3	Ener Grease LS3
CENTURY	WLP	428AP		Spheerol AP3	Spheerol AP3
DUCKHAMS	Galrex 9	Adglide 6		Lupus 3	Lupus 3
ESSO	Esstic 78	Febis K73		Admax 13	Admax 13
GULF	Mechanism LP 85	Gulway 52 or Slidway 52		Beacon 2/3	Beacon 2/3
MOBIL	DTE oil BB	Vectra Oil		Gulfcrown No. 3	Gulfcrown No. 3
PETROFINA	Solna 58	Artac 37		Mobilplex 48	Mobilplex 48
SHELL ISO VG NO:	220	68 or 320		Marson HTL 3	Marson HTL 3
TEXACO	Regal GR & O	Way Lubricant D		Alvania R2 & R3	Alvania R2 & R3
VAUGHAN	Cosmolub-ric EHC	Way Lubricant		Regal Starfal Premium 3	Regal Starfal Premium 3
				Evco BB No. 3 Grease	*Cosmolube Grease/No4 Grease

REMARKS:

For Slideways Grade 5 is suitable for use with oil-base coolants and Grade 7 for use with water-base coolants.

* Re: Cosmolube No. 4: Use sparingly and only in nose cap seals.

Fig.3.1 Lubrication Chart 1"-6, 1"-6S and 30mm-6. Drawing No.168Z10B

1. 12 point feed block
2. 8 point feed block
3. 4 point sight feed, 10-20 drops per minute
4. 6 point feed block
5. 7 point feed block
6. Pressure gauge
7. Micronic filter
8. Relief valve
- 8A. Drip tray
9. 10 point feed block
10. Spray pipes
11. Pump
12. Purolator
13. Pressure gauge 20 psi (1.36 bar)
14. Micronic filter: remove top to replace element
15. Slide bases
16. Spindle front bearing caps (grease 1 nipple per spindle)
17. Front cut-off slide
18. Upper cross slides
19. Rear forming slide
20. Slide bases
21. Lower cross slides
22. Stroke setting block
23. Purolator, turn daily
24. Bar feed lever
26. Roller pin
27. Cam Drum
28. Bar feed roller pin
29. Cam shaft
30. Collet operating lever
31. Roller pin
32. Grease stock tube springs periodically
33. Lubrication diagram
34. Relief valve
35. Oil sump 10 gallons (45 litres).
Dipstick shows high and low levels.
Fill through Filler/Breather/Strainer
36. Bar feed slide
37. Collet operating slide
38. Latch
39. Motor: grease every six months
40. Strainer
41. Dip stick

Fig.3.1 Lubrication Chart 1"-6, 1"-6S and 30mm-6. Drawing No.168Z10B

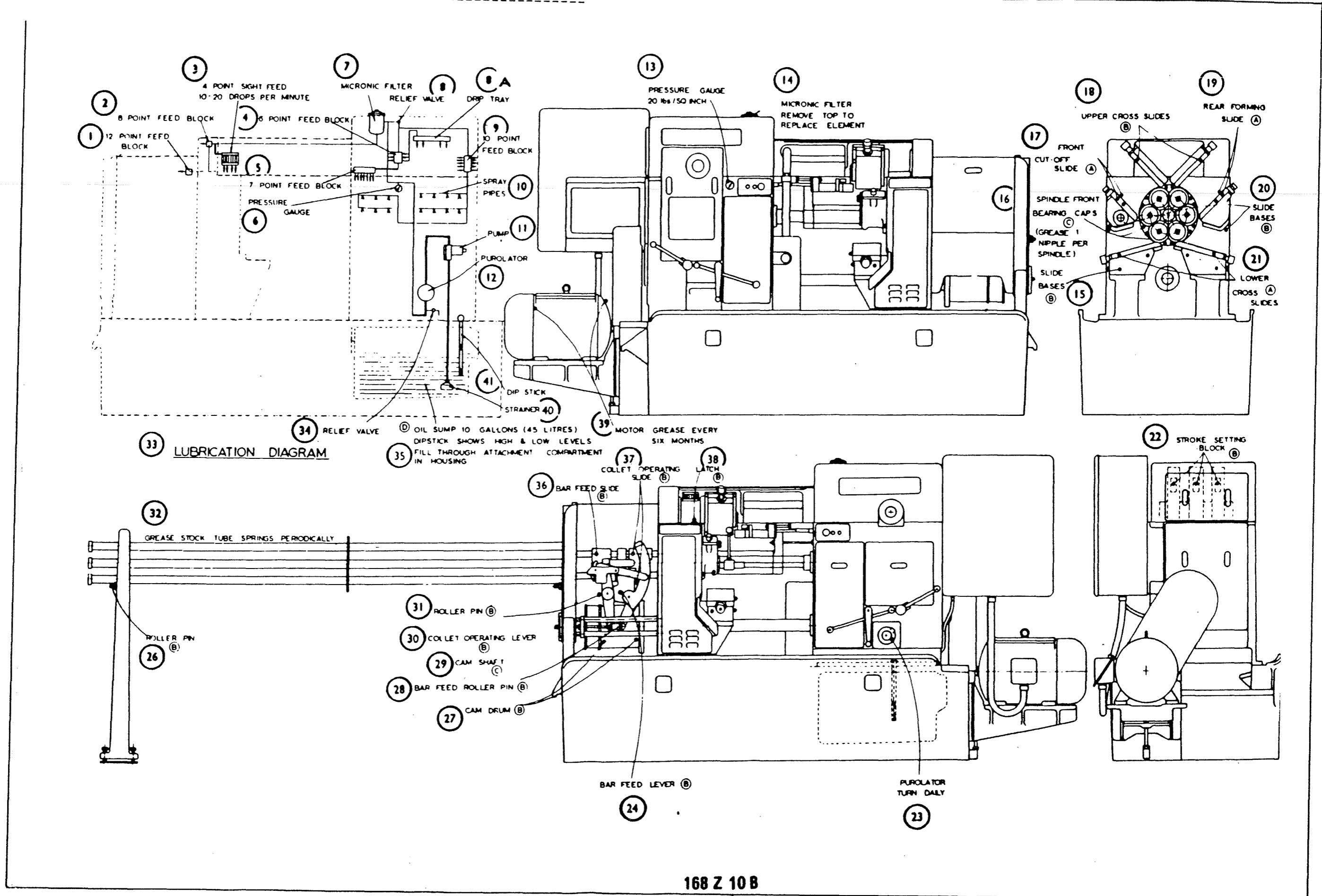

168 Z 10 B

Lubrication Notes

SECTION FOUR - PREVENTATIVE MAINTENANCE SCHEDULE

4.1 1000 Hour Procedures

WARNING

Isolate the machine electrically before carrying out any preventative maintenance schedules.

Work Schedule to be carried out after 200, 1,000, 2,000, 3,000 hours running, at 1,000 hour intervals thereafter.

Cross Slide Felt Wipers & Aprons: Inspect and check for damage. Remove swarf particles.

Change Gear Securing Nuts: Check tightness.

Attachments and Tooling Equipment
Securing Nuts: Check tightness.

Chasing Attachment Drive (if fitted): Inspect drive chain, check tension, Remove covers and check lubrication. Push back gaiter covers on universal joints and inspect.

Feed Drive - Brake Clutch: } Inspect and check adjustment (see
Feed - Fast Clutch: } Sec.5.23 and machine plate).
Threading: } Check drive chain tension
Drive Clutch: }

Collet Operating Shoe: } Inspect for correct alignment and
Bar Feed Shoe } lubrication. (Renew when worn).

Six Collet Operating Sleeves: Inspect for correct alignment and movement to avoid overheating.

Bar Feed Mechanism: Check adjustment.

Bar Feed Mechanism Aligning Ring: Inspect for alignment.

Cyclic System: Inspect for leakage caused by loose connections and damaged tubing.

Upper Camshaft: Check tightness of bolts on coupling between wormwheel and shaft.

Main Block Positive Stop: Check for excessive pressure.

Independent Slides Positive Stop: Check for excessive pressure.

Cross Slide Positive Stops: Check for excessive pressure.

Drum Housing:
Main Drive Housing: Clean lubricating oil sumps.

Coolant System: Clean tray, taps, pipes and ducts (including manifolds).

Bar Feed Tube Assemblies: Remove and thoroughly clean. Inspect Feeders.

Collet Tubes, Collets:	Remove and thoroughly clean. Inspect Collets.
Spindle Bore and Collet Seating:	Clean. Inspect collet keys for excessive wear.
Longitudinal Slides:	Pull quadrants back, push forward to check free movement. Adjust gib strip if required.
Spindle Speed and Feed Change Gears:	Inspect lubrication.
Main Drive Housing:	All chain drives, check adjustment and sprocket alignments.
All Cams and Cam Rollers:	Inspect for excessive wear, oil, rollers and pins.
Spindle Drum:	Check end float (see Sec.5.6)

4.2 2000 Hour Procedures

Work Schedule to be carried out after 200, 2,000, 4,000 hours running, at 2,000 hour intervals thereafter.

Intake Strainer for Pump on Continuous Lubrication System:	Inspect and Clean.
Interlube Cyclic Metered Lubrication System if fitted:	Check frequency of operation.
Main Drive Belts:	Remove cover, check belt tension and inspect for excessive wear.
Handwind Interlock System:	Inspect and check (see handbook).
Bar Feed Spring:	Check setting.
Control Panel Wire Connections:	Check for tightness.
Control Panel:	Hand operate contactors and relays, ensure free action.
'PUROLATOR' Metal Edge Filter:	Remove, clean filter and case, refit.
'PUROLATOR' "Micronic" Cartridge Filter:	Remove bowl, renew cartridge.
Upper and Intermediate Cross Slides:	Strip, Clean, refit and adjust gib strip.
4th & 5th Station Longitudinal Slides:	Strip, Clean, refit and adjust gib strip.
Chasing Attachment (if fitted):	Strip, Clean, inspect for wear, refit.
Stock Carriage:	Remove springs, clean, regrease, renew as necessary.
Feed Tube: Steady Bushes:	Examine and renew if worn.
Spindles, Collet Operating Toggles:	Strip and examine for wear. (Renew in matched pairs).
Pulley Shaft:	Check for oil leak adjacent to pulley, and renew oil seal if necessary.
Spindles:	Remove collet operating sleeve, examine internal form. Check for correct movement.
Conveyor:	Remove from machine and clean thoroughly. Examine for damage, adjust and refit as necessary.
Spindle Drum:	Check indexing, measure over index. (see Sec.5.7).

Drum Locking:	Check setting (see Sec.5.7).
Drum Latch:	Check setting, inspect for excessive wear.
Interlube Cyclic Metered Lubrication if fitted:	Drain and clean reservoir.
Centre Block:	Drain and flush. Clean Strainer on guide block. Adjust gib strip if required. Do not over-tighten.
Attachments:	Strip attachment slides, clean, refit and adjust. Inspect, replace worn items. Gears, bearings, splined shafts, clutch parts etc.
Switches:	Check setting, ensure free action, inspect for mechanical damage, check securing screws.
Flexible Electrical Conduits:	Inspect for damage.
Lower Cross Slides:	Strip, clean, refit and adjust gib strip. Replace aprons and felt if worn.
Conveyor Drive Motor Bearings:	See manufacturer's Service Sheets or follow a known procedure for low power motor maintenance.
Upper Camshaft Housing:	Check oil supply to drip tray and outlets.

4.3 4000 Hour Procedures

Work Schedule to be carried out after 4,000 and 8,000 hours running, at 4,000 hour intervals thereafter.

Coolant Pump (Gear Type Only):	Strip and Clean, examine gears, shafts and gland. Renew as required. Refit.
Continuous Lubrication System:	Remove and strip pump, clean and examine for wear. renew as required. Refit.
Main Drive Housing:	Examine lower and upper camshaft. Worm and Wormwheel. Drives for wear. Replace worn gears.
Spindle Drum, Spindle: Drive Gears:	Examine for wear. Renew if worn.
Cross Slides, Upper and Intermediate:	Replace return springs.
All Chain Drives:	Renew worn chains.
Drum Locking:	Renew Cam Roller and Pin if necessary. Examine Cam and Renew if worn.
Bar Stop Mechanism:	Strip Covers and examine cams, rollers and pins. Replace if worn.
Spindle Assembly:	Remove feed tube assemblies and examine. Replace worn bearings. Remove spindle nose caps, examine piston ring seals, replace if worn.

4.4 12000 Hour Procedures

Work Schedule to be carried out after 12,000 hours running.

Longitudinal Motion:	Examine bushes, and pins, replace as necessary.
Camshafts:	Examine for worn keys and keyways.
Cross Slide Operation:	Dismantle front and rear cam levers and renew bushes. Remove links and cross slide levers and renew bushes and pins and worn shafts.
Main Drive Housing:	Examine initial drive shafts (3). Replace if worn.
Drum Housing & Drum:	Withdraw spindle drum, examine front bearing area on drum & in housing for excessive wear and damage. (Consult Wickman Engineer). Examine drum seal, replace if worn.

SECTION FIVE - MACHINE CONSTRUCTION AND MAINTENANCE PROCEDURES

5.1 Main Frame

The frame comprises the tray which forms the base; the drum housing; the main drive housing and the beam. These main castings are bolted and dowelled together to form a rigid closed frame. The end bracket is bolted and dowelled to the tray and supports the front end of the stock carriage. It is connected to the drum housing by two guide rods on which the bar feed and the collet operating slides are mounted.

5.2 Main Drive

The motor, fig.5.1 Drg.100Y151 is mounted on an adjustable platform which is bolted to the end face of the tray. The drive is by matched Vee belts. The motor platform can be raised or lowered by slackening the four nuts holding it to the tray and then adjusting the jack screw beneath the platform. After adjusting the motor always ensure that the nuts are retightened before starting the motor.

Main Drive Gearing. Fig.5.2 Drg.100Z67

From the pulley shaft 'A', the second shaft 'B' is driven by means of the range of change gears which provide high and low speed ranges. The speed range is changed by sliding the double gear along its shaft. The double gear is located by means of a spring plunger which engages grooves in the shaft. A neutral position is provided. The speed pick-off gears transmit the power from this shaft to the centre shaft 'C'. The centre shaft extends through the attachment compartment to a coupling. From the coupling an extension of the centre shaft passes through the centre guide to the spindle drum. Fig.5.3 Drg.100Z54B.

Access to the speed pick-off gears is at the end of the main drive housing. They are mounted on taper shafts and an extractor is supplied with the tool kit. Gears and shafts should be cleaned before fitting.

The feed drive is taken from the centre shaft by gears. The fast motion drive is taken from the pulley shaft by gears through the fast motion slipping clutch. This slipping clutch is provided to protect the machine against excessive overload during the fast motion part of the cycle. If the fast motion safety clutch is disengaged as a result of an overload, the drive is transferred to the feed drive through the feed slipping clutch, and if this disengages, it operates the feed trip mechanism as described in Section 5.1. of the Operator's Handbook. Before re-engaging the slipping clutch, the cause of the overload must be located and corrected.

The oil pump is chain driven from the pulley shaft. The oil pump is mounted on an eccentric sleeve which can be turned to adjust the tension of the chain. The eccentric bush is locked by means of the notched nut behind the pump sprocket. Fig.5.4 Drg.100Z68A.

5.3 Feed Gearing

The feed drive is taken by gears from the centre shaft to the first pick-off gear shaft. The feed pick-off gears take the drive to the second pick-off gear shaft. The feed pick-off gears are mounted on taper shafts and an extractor is supplied in the tool kit. Access to the pick-off gears is at the end of the main drive housing.

The second pick-off gear shaft carries the feed slipping clutch. This is provided to protect the machine from excessive over-load during the feed portion of the cycle and is arranged so that it completely disengages and operates the limit switch mounted

adjacent to it and trips the feed trip mechanism, as described in Section 5.17. Before re-engaging the slipping clutch, the cause of the overload must be located and corrected. The slipping clutches are re-engaged by sliding the body along until the dogs re-engage.

The gear engaging the feed slipping clutch on the second pick off gear shaft drives the feed gear and its plate clutch assembly. A roller over-run clutch is also built into this assembly. This takes the drive during the feed portion of the machine cycle whilst the feed clutch is engaged and the fast motion clutch is dis-engaged. On dis-engaging the feed clutch and engaging the fast motion clutch, the roller over-run clutch allows the fast motion drive to over run the feed drive.

The fast motion drive to the feed/fast motion shaft is taken from the pulley shaft through the fast motion slipping clutch, the driving gear the driven gear and the fast motion plate clutch assembly.

The fast motion and the feed motion plate clutches are operated by a lever controlled by cam dogs on the face of the upper longitudinal slide camshaft worm wheel. This lever is link connected to a further lever on the control shaft which carries the operating yoke actuating either the fast or feed motion clutches. The link is adjustable for length in order to set the correct travel for the clutch operating sleeve. This is set before the machine leaves the Wickman Bennett plant and should not normally require adjustment, see fig.5.5 Drg. 100Z84.

Adjacent to the fast motion driven gear on the feed/fast motion shaft is the final drive gear to the feed shaft. It engages with and drives the driven gear/outer member of the 24 volt DC electro-magnetic feed clutch, which when energised drives the mating dog clutch sleeve and the feed shaft.

The feed shaft is carried in roller bearings and supported by the end wall and the inner attachment drive compartment wall of the main drive housing.

The electro-magnetic brake is mounted outboard on the end wall of the main drive housing. The outboard end of the feed shaft and its braking plates assembly are spring engaged and electro-magnetically released. The operation of the feed stop button de-energises the feed clutch and the brake clutch thus allowing the brake springs to apply the feed brake. The "feed Stop" button should always be used for stopping the feed and applying the brake. Do NOT use the FEED DRIVE LEVER for this purpose. To hand wind the machine it is first necessary to press the feed stop push button to arrest the feed. The feed drive shaft dog clutch operating lever may now be lifted until it comes against a stop and retains itself. The action of lifting this lever disengages the feed dog clutch through which power could be transmitted, trips the feed dog clutch interlock switch to open the feed circuit and moves the mechanical interlock lever into the position where it is possible to slide the hand wind pinion into mesh with the hand wind gear mounted on the lower worm shaft.

The action of sliding the pinion into mesh trips the hand wind interlock switch which energises the electro-magnetic brake, thus releasing the brake allowing the hand-winding to take place. In the event of a machine not having electric power available the brake will be applied and handwinding will not be possible.

In order to overcome this, two retraction screws are provided in the brake cover. Insert the screws through the holes left by removing the knurled headed plugs and screw them into the brake unit until the

brake armature plate is solidly retracted. Handwinding is now possible. It is impossible to engage the feed until the screws have been removed and it is impossible to lower the feed drive lever from the handwind position whilst the handwind crank is on its shaft. The electro-magnetic brake should be adjusted to obtain the correct air gap as instructed on the adjacent instruction plate. Lubrication is by drip feed to the clutch plates and bearings.

Faults affecting the feed and motor circuits.

The feed will disengage, the fail-safe spring brake will be applied and the motor will stop and cannot be restarted until the fault due to the following circumstances has been corrected.

(a) The feed slipping clutch disengages.

When the feed trip cam switch operates, the feed will disengage, the brake will be applied and the motor will stop and cannot be restarted until the fault due to the following circumstances has been corrected.

(a) Threading return check switch not closed on completion of attachment return stroke.

(b) Bar expired switch open due to bar exhaustion.

(c) Rotary selector switch.

The upper worm shaft is driven from the sprocket through a dog clutch. This dog clutch can be disengaged by slackening the nut on the shaft, which allows the upper worm shaft to be rotated by means of the square end while the lower camshaft remains stationary, thus enabling the timing to be altered or corrected as required. Alternatively, the machine can be hand cranked with the dog clutch disengaged until the timing required is obtained.

The timing is best set at 0 deg. At this timing the Geneva roller is about to enter the Geneva wheel. A timing hole is provided in the bar stop cam disc and lines up with a corresponding 1/2" dia. hole in the drum housing at 0 deg, fig.5.6 Drg.100Z57A. A groove is cut on the outside diameter of each of the longitudinal slide cam discs which is at 12 o'clock at 0 deg timing.

The upper camshaft may be advanced or retarded relative to the main camshaft. Should this be necessary, the dogs on the upper wormwheel face, for changing from fast motion to feed and vice versa and the cam plate for the feed trip should be retimed to suit the main camshaft.

Fig.5.1 Drg.100Y151

- 1. Belt Guard
- 2. Locking Nuts
- 3. Motor Platform
- 4. Jack Screw

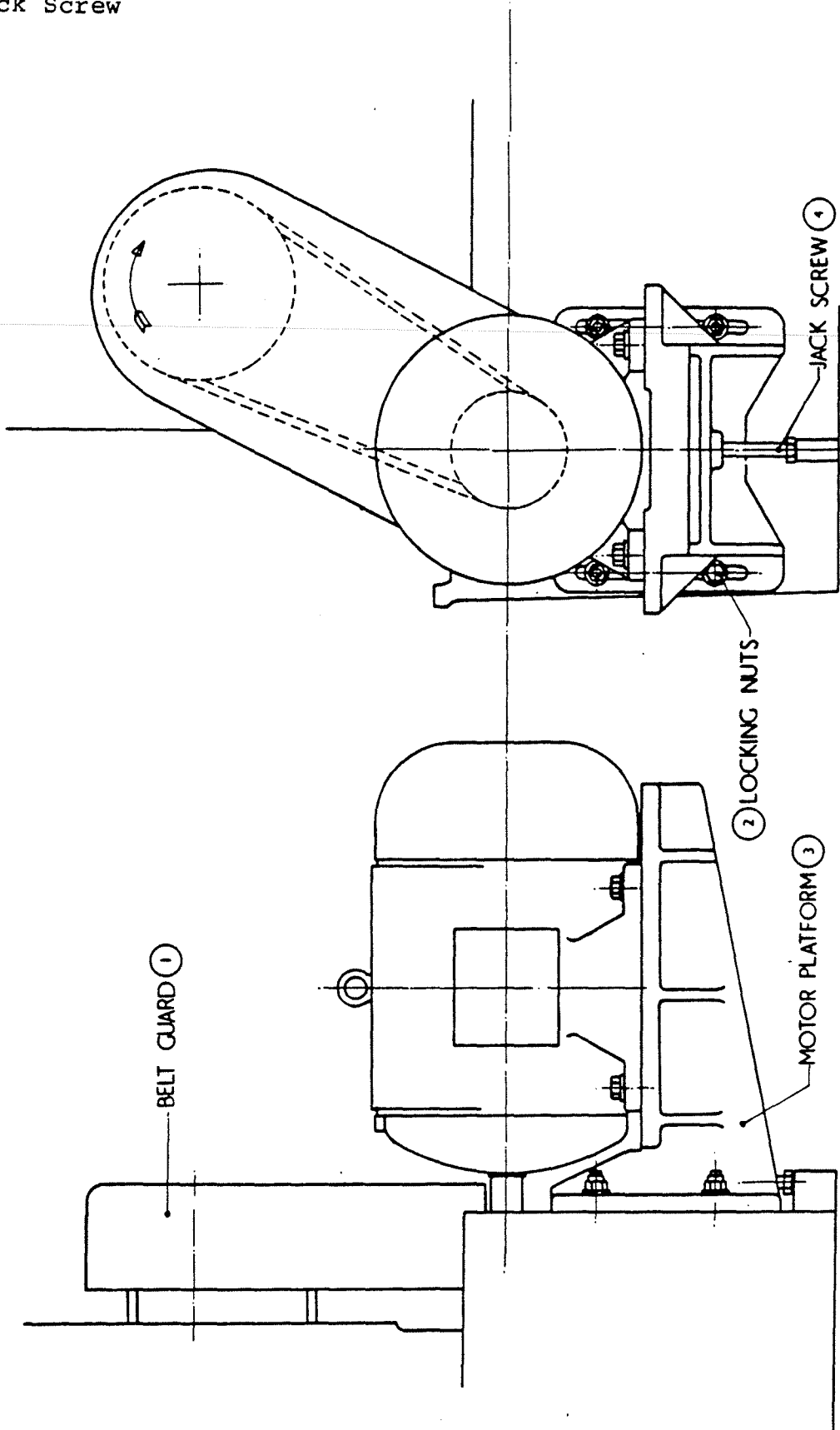
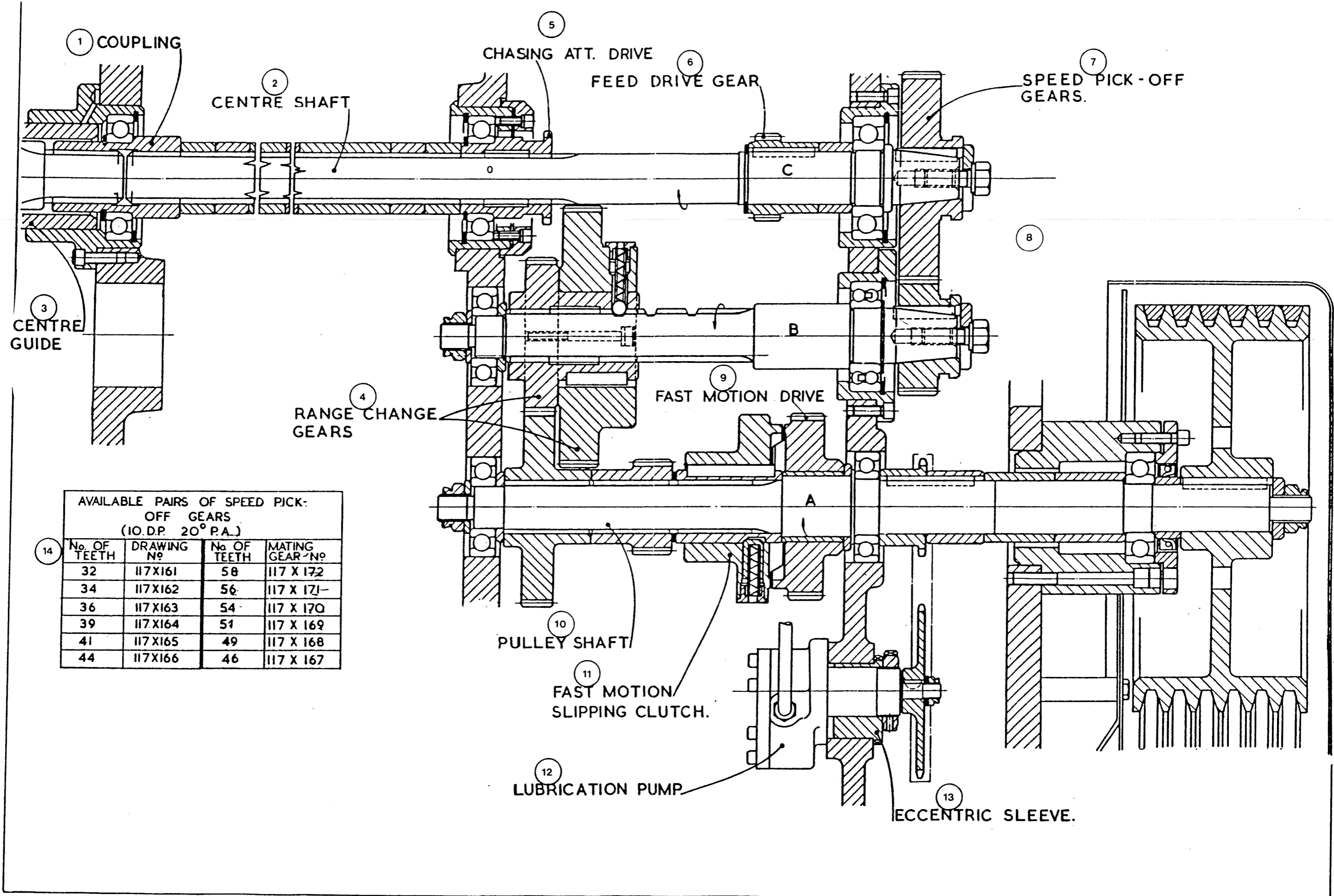

Fig.4.2 Drg.100Z67

1. Coupling
2. Centre Shaft
3. Centre Guide
4. Range Change Gears
5. Chasing Attachment Drive
6. Feed Drive Gear
7. Speed Pick-off Gear
8. Not Applicable.
9. Fast Motion Drive
10. Pulley Shaft
11. Fast Motion Slipping Clutch
12. Lubrication Pump
13. Eccentric Sleeve
14. Available pairs of Speed Pick-off Gears (10 D.P. 20 deg. P.A.)
No. of Teeth
Drawing No.
No. of Teeth
Mating Gear No.



14

AVAILABLE PAIRS OF SPEED PICK-OFF GEARS (10.D.P. 20° P.A.)			
No. OF TEETH	DRAWING No	No. OF TEETH	MATING GEAR No
32	117X161	58	117 X 172
34	117X162	56	117 X 171
36	117X163	54	117 X 170
39	117X164	51	117 X 169
41	117X165	49	117 X 168
44	117X166	46	117 X 167

Fig.5.3 Drg.100Z54B

1. Work Spindles
2. Spindle Stopping Drum
3. Work Spindles
4. Diehead Drive Sec.182
5. Range Change Gears
6. Drive Belts (6 Off)
7. Fast and Slow Dogs
8. Timing Dial
9. Upper Camshaft
10. Cams for Longitudinal Slides
11. Fast Motion Slipping Clutch
12. Cam Timing Switch
13. Lubrication Pump
14. Speed Pick-Off Gears
15. Feed Pick-Off Gears
16. Motor
17. Feed Slipping Clutch
18. Electro-Magnetic Release Spring Applied Brake
19. Fast Motion Clutch
20. Electro-Magnetic Feed Clutch
21. Handwind Dog Clutch
22. Handwind Gear
23. Drum for Stn.6 Cams
24. Drum for Stn.4 Cams
25. Main Camshaft
26. Cross Slide Cams
27. Bar Stop Cam
28. Drum Locking Cam
29. Collet Operation Cams
30. Index Clutch
31. Bar Feed Cams
32. Index Gears
33. Geneva Wheel
34. Centre Gear
35. Spindle Drum
36. Chasing Drive
37. Threading Clutch Sec.183
38. High Speed Drill Sec.190
39. Threading Attachment
40. Coupling
41. Threading Attachment Sec.186
42. Off
43. On

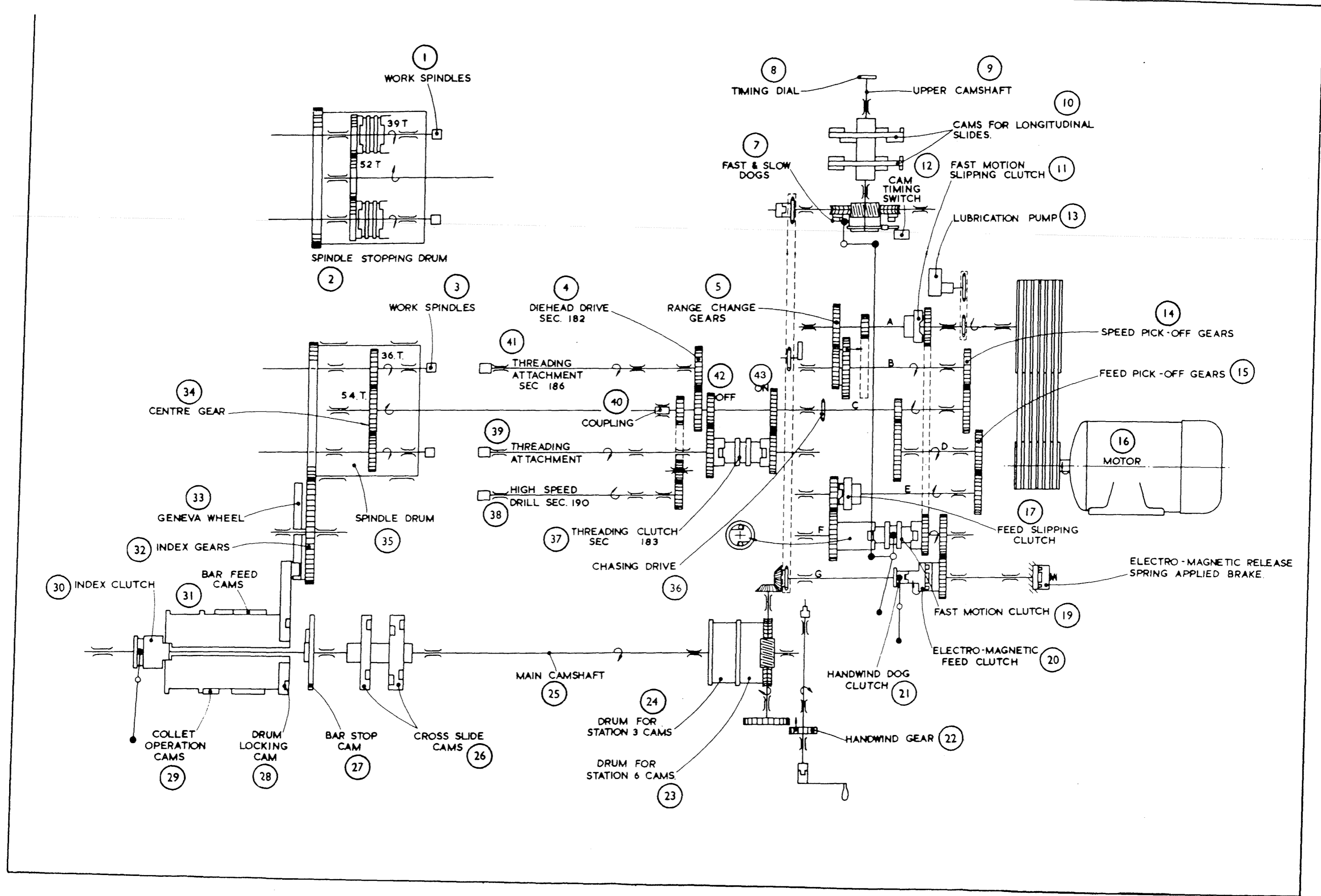
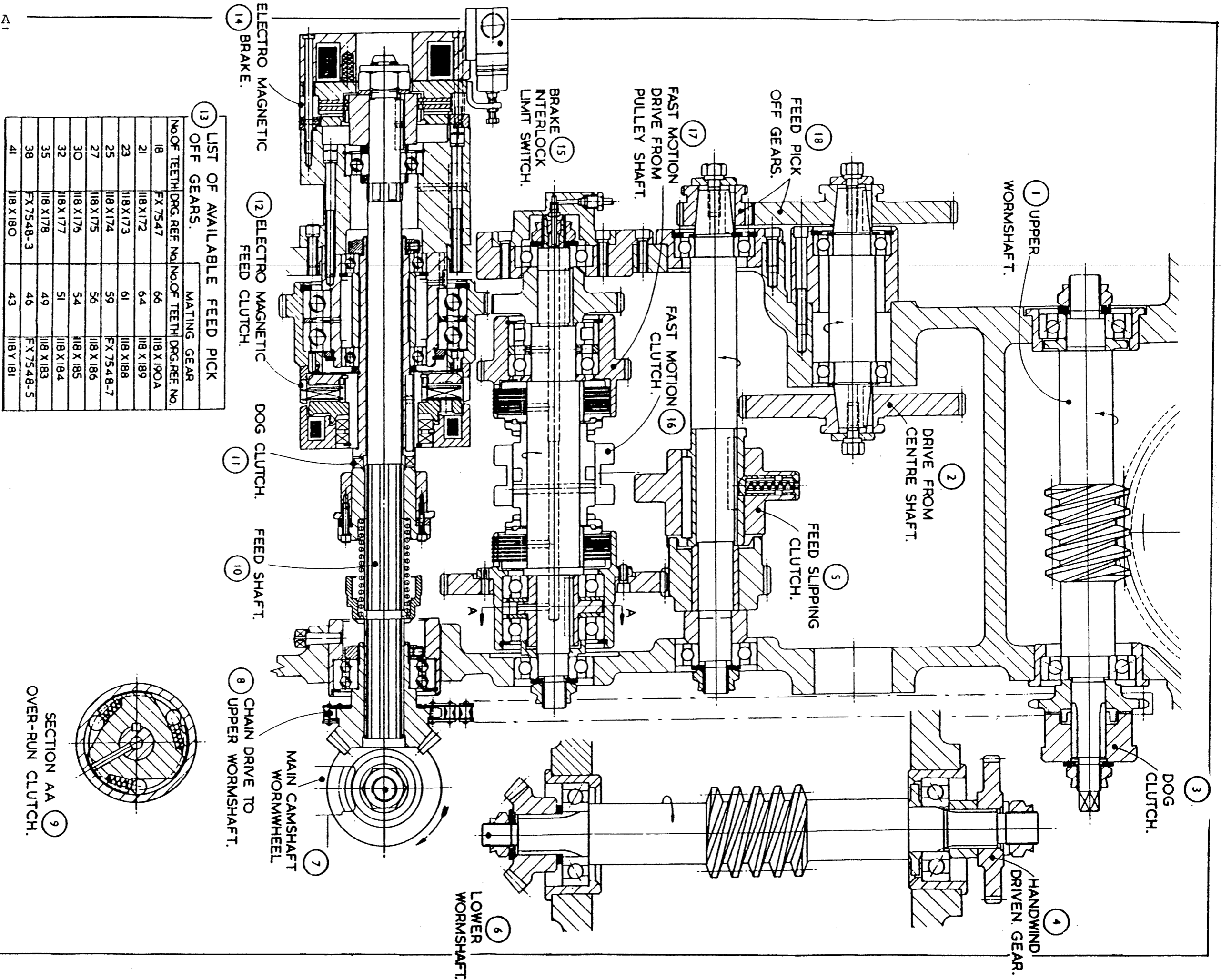

Fig.5.4 Drg.100Z68A

1. Upper Wormshaft
2. Drive from Centre Shaft
3. Dog Clutch
4. Handwind Driven Gear
5. Feed Slipping Clutch
6. Lower Wormshaft
7. Main Camshaft Wormwheel
8. Chain Drive to Upper Wormshaft
9. Section AA Over-run Clutch
10. Feed Shaft
11. Dog Clutch
12. Electro-magnetic Feed Clutch
13. List of available Feed Pick-Off Gears
14. Electro-magnetic Brake
15. Brake Interlock Limit Switch
16. Fast Motion Clutch
17. Fast Motion Drive from Pulley Shaft
18. Feed Pick-Off Gears



13 LIST OF AVAILABLE FEED PICK OFF GEARS.

No. OF TEETH	DRG. REF. NO.	No. OF TEETH	DRG. REF. NO.
18	FX 7547	66	118 X 190A
21	118 X 172	64	118 X 189
23	118 X 173	61	118 X 188
25	118 X 174	59	FX 7548-7
27	118 X 175	56	118 X 186
30	118 X 175	54	118 X 185
32	118 X 177	51	118 X 184
35	118 X 178	49	118 X 183
38	FX 7548-3	46	FX 7548-5
41	118 X 180	43	118 X 181

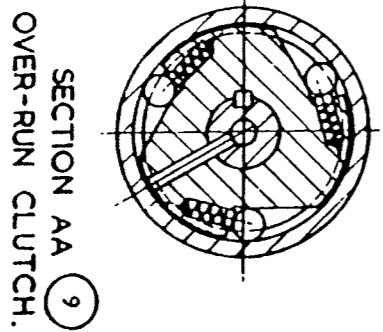
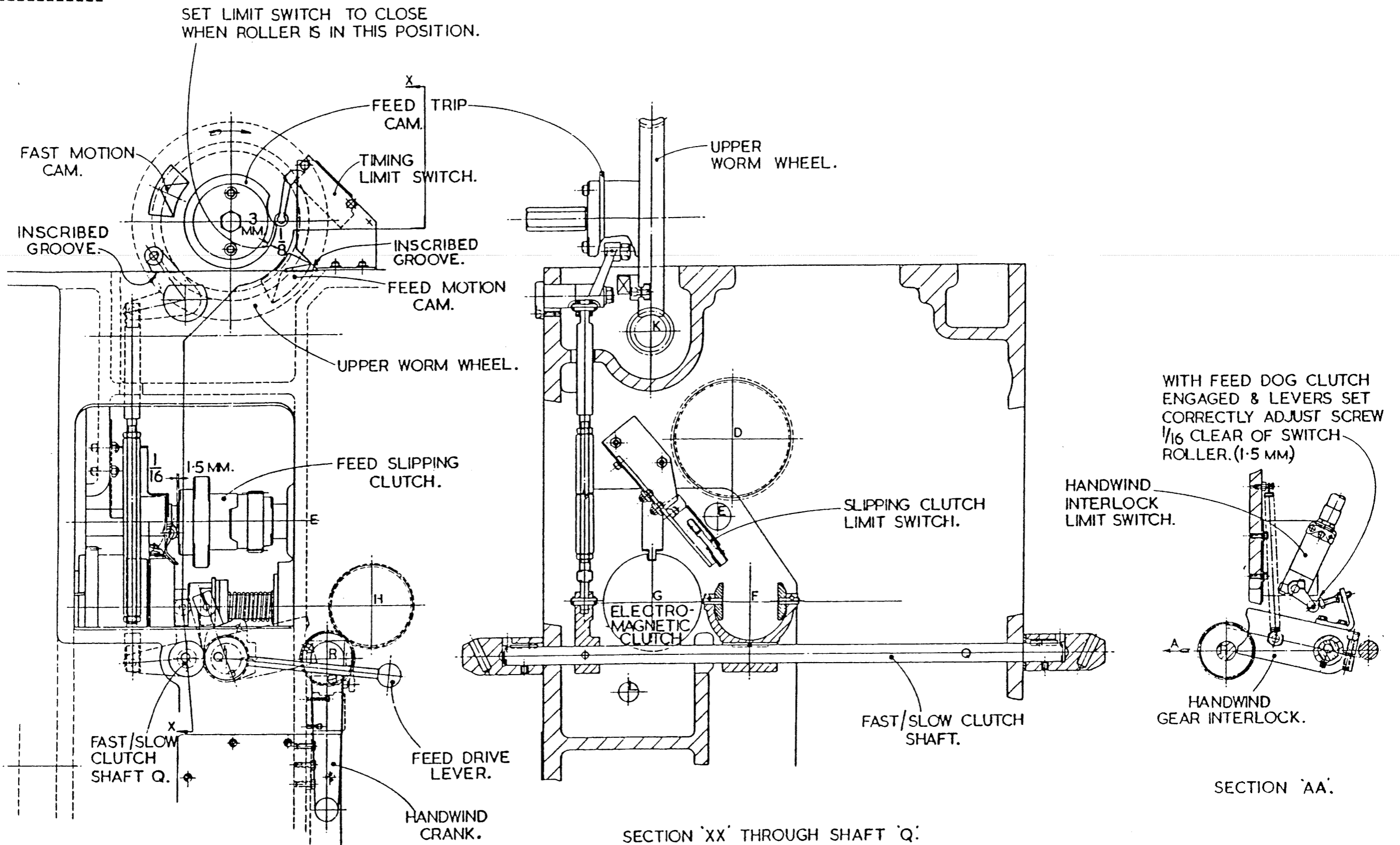

Fig.5.5 Drg.100Z84

1. Fast Motion Cam
2. Set limit switch to close when roller is in this position
3. Timing Limit Switch
4. Feed Cam
5. Trip
6. Upper Worm Wheel
7. With feed dog clutch engaged & levers set correctly adjust screw
1/16" (1.5mm) clear of switch roller
8. Handwind interlock limit switch
9. Handwind Gear Interlock
10. Section 'AA'
11. Slipping Clutch Limit Switch
12. Fast/Slow Clutch Shaft
13. Section 'XX' through Shaft 'Q'
14. Electro-Magnetic Clutch
15. Feed Drive Lever
16. Handwind Crank
17. Fast/Slow Clutch Shaft 'Q'
18. Feed Slipping Clutch
19. Upper Worm Wheel
20. Feed Motion Cam



WITH FEED DOG CLUTCH ENGAGED & LEVERS SET CORRECTLY ADJUST SCREW 1/16 CLEAR OF SWITCH ROLLER. (1.5 MM)

100 Z 84

Fig.5.6 Drg.100Z57A

1. Auxiliary Cross Slide Motion
Station 3 - Section 193
Station 4 - Section 193A
Station 5 - Section 193B
Station 6 - Section 193C
2. Fulcrum for 3rd and 4th Station Slides
3. Cross Slide moves the same as Roller: 1.3/4in (44.5mm)
maximum travel
4. Return Spring
5. Timing Hole in Bar Stop Cam Carrier
6. Drum Locking Lever
7. 1/8in (3mm) extension when fully locked
8. Spring Box
9. To adjust Link loosen Locknut and turn Spring Box
10. Geneva Wheel
11. Spindle Drum Thrust Block
12. Stop
13. Stop Screw
14. Bar Stop Lever
15. Bar Stop set to operate in "up" position
16. Bar Stop set to operate in "down" position
17. 1/2in (12mm) thickness of Cams
18. Maximum that Screws should enter Cam Disc is 7/16in (11mm)
19. Timing Hole in Drum Housing
20. Spare Cam Disc
21. Fulcrum for 5th and 6th Station Slides
22. 1.1/4in (32mm) Roller dia.
23. Maximum travel of Roller
24. Timing Angle 0 deg.
25. 4 Holes 5/16in B.S.F. on 4.5/8in (117.5mm) P.C. radius
10 Holes 5/16in B.S.F. on 2.7/8in (73mm) P.C. radius
10 Holes 5/16in B.S.F. on 5.1/4in (1333mm) P.C. radius
26. Spare Cam Disc
27. Direction of Rotation

Fig.5.6 Drg.100Z57A

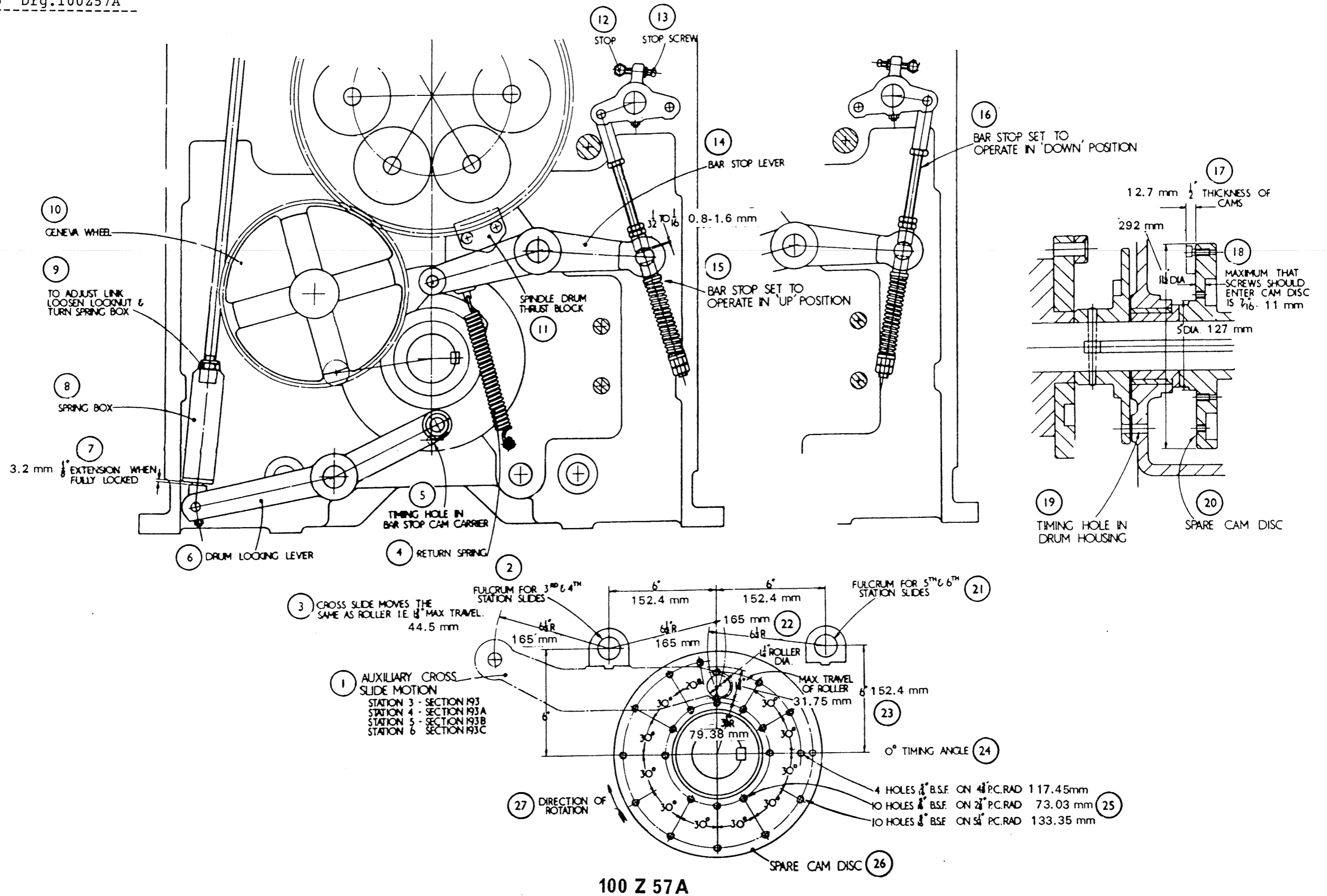
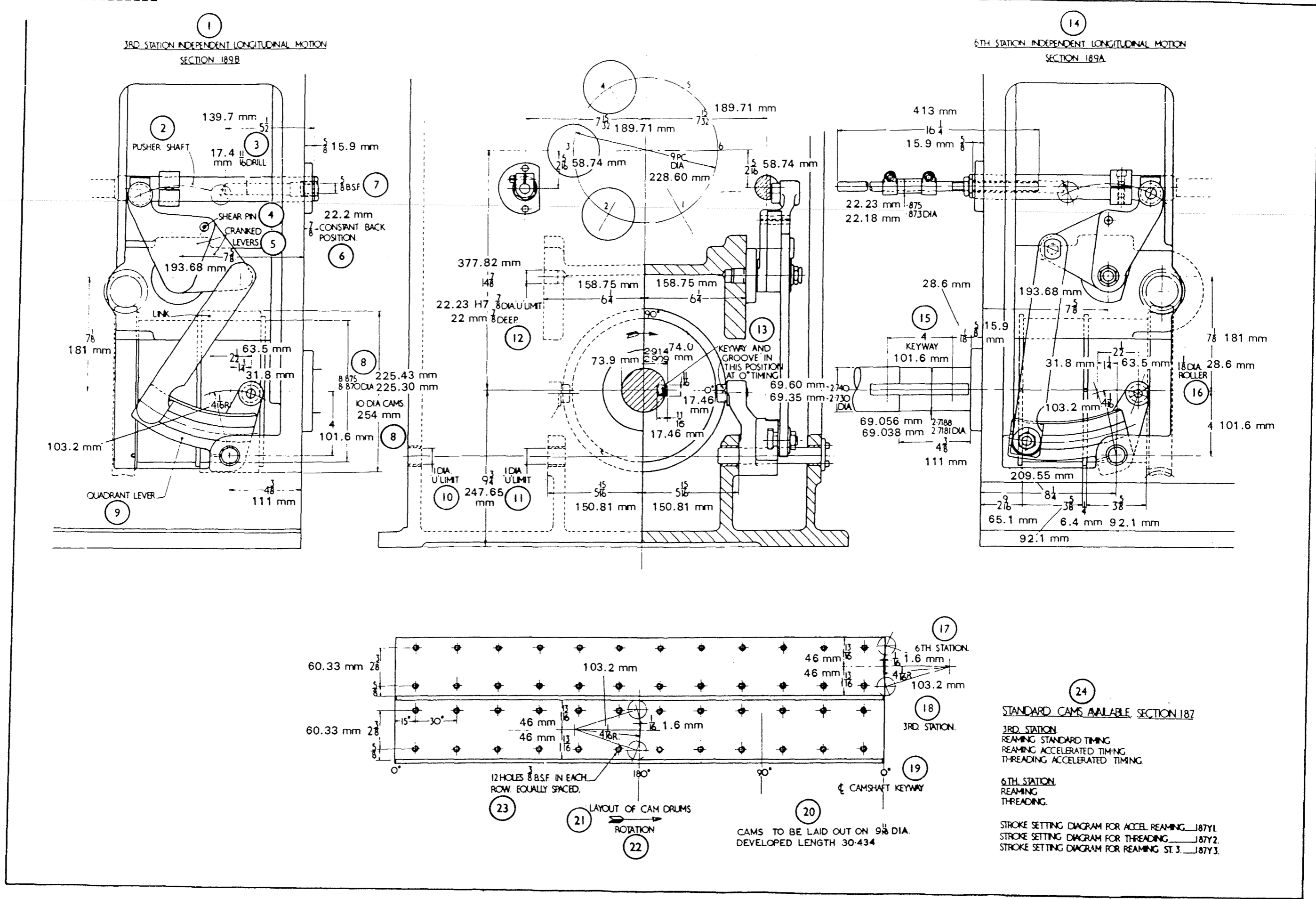

Fig.5.7 Drg.189Z10

1. 3rd stn. independent longitudinal motion. Sec.189B
 2. Pusher shaft
 3. Drill
 4. Shear Pin
 5. Cranked levers
 6. 22mm constant back position
 7. 5/8" BSF
 8. Diameter / Cams diameter
 9. Quadrant lever
 10. Diameter 25.4mm H7
 11. Diameter 25.4mm H7
 12. 22.23mm H7. x 22mm deep
 13. Keyway and groove in this position at 0 deg. timing
 14. 6th stn. independent longitudinal motion. Sec.189A
 15. Keyway
 16. 28.6mm diameter roller
 17. Station 6
 18. Station 3
 19. Camshaft Keyway
 20. Cams to be laid out on 23.65mm dia / Developed length 30.042mm
 21. Layout of cam drums
 22. Direction of rotation
 23. 12 holes 3/8" BSF in each row, equally spaced
 24. Standard cams available. Sec.187
 - 3rd station:
 - Reaming standard timing
 - Reaming accelerated timing
 - Threading accelerated timing
 - 6th station:
 - Reaming
 - Threading
- Stroke setting diagram for accelerated reaming - 187Y1
Stroke setting diagram for threading - 187Y2
Stroke setting diagram for reaming, stn.3 - 187Y3

Fig.5.7 Drg.189Z10



5.4 The Main Camshaft

The main camshaft extends from the wormwheel in the main drive through the drum housing to the end bracket. It carries the cross slide feed and approach stroke cams, bar stop, bar feed, and collet operating cams, spindle drum locking cams, the geneva roller and the index clutch. End thrusts on the camshaft are taken by angular contact ball bearings in the end bracket.

Two cam drums are fitted in the main drive housing which carry the reaming and threading cams, these being fitted when required. Special cams may also be fitted when necessary. Fig.5.7 Drg.189Z10. These cams normally operate the auxiliary longitudinal motions. Sections 189A and 189B which are arranged to operate standard and special attachments in 3rd and 6th stations.

A portion of the camshaft in front of the main drive housing is provided with a keyway. This enables special cam drums to be fitted at this point.

On the back of the rear cross slide cam disc in the drum housing, a clear face is left which is provided with tapped holes to enable special cams to be fitted. Fig.5.6. These cams can operate any one cross slide through the appropriate auxiliary cross slide motion. Section 193, 193A, 193B or 193C.

5.5 Upper Camshaft

The upper camshaft is transversely mounted in brackets across the top of the main drive housing. It carries the disc cams which operate the centre tool block and the longitudinal slides and is driven by the wormwheel at the rear. Fig.5.8 Drg.100Z148.

The cam dogs controlling the fast motion clutch are mounted on the face of the wormwheel. Normal timing is for the fast motion dog to engage the clutch at the end of "dwell" (268 deg timing), and for the slow motion dog to engage at the start of "feed" (112 deg timing), see timing diagram, fig.5.9 Drg.100Y29A. The cam plate for the feed trip is in front of the wormwheel. The timing dials are mounted on each end of the camshaft.

5.6 The Spindle Drum (Fig 5.9) (100Z66)

The spindle drum carries the work spindles and the centre guide on which the centre tool block slides, so ensuring consistent alignment of the work spindles with the centre tool block.

End thrusts on the spindle drum are taken by three thrust blocks on the rear of the drum housing. Should end float develop, the thrust blocks should be removed and their faces carefully adjusted so that a 0.002" feeler gauge can be inserted between the thrust block and the flange of the drum.

The spindle drum is indexed anti-clockwise, looking at the collets, by gearing from the Geneva wheel. At each cycle the spindle drum is indexed slightly past the correct position to allow the drum latch to drop into position. It is then drawn back by the drum locking mechanism and clamped against the hardened and ground locators. See Drg.100Z66, fig.5.9.

5.7 Drum Locking

To adjust drum locking mechanism, release the set screw clamping the setting screw and adjust so that the clamping pressure required is just sufficient to allow the mechanism to "lock" when tested by means of a tommy bar in the operating lever with the drum locking rod at the end disconnected, see fig.5.10(100Y58). The locknuts on the end of the spring rod are adjusted to the dimension shown. If they are adjusted too high the machine may fail to lock correctly. This may occur during operating satisfactorily when handwinding. If the nuts are too low the mechanism will not clear the spindle drum during indexing.

The drum locking rod at the rear of the drum housing should be set for length so that the spring box extends 1/8" when fully locked, See Fig.5.6,(100Z57A). This may be set by releasing the locknut and turning the spring box. Ensure that the locknut is retightened when adjustment is complete.

5.8 Work Spindles

The work spindles are mounted in extra precision pre-loaded anti-friction bearings. The front caps of the spindles carry the stop screws for the cross slides. The stop screws can be adjusted so that the slightest variation between spindles can be eliminated by the stop pressure.

The bearings are lubricated from sight feeds on the beam above the drum housing.

The bar is fed out in 6th station after the feed cycle has finished and immediately prior to indexing.

The collets, which are of the draw-in style, are operated by a toggle mechanism on the end of the work spindles. The collets may be removed by drawing back the spring plunger and turning the left-hand threaded adjusting sleeve. This will release the collet complete with its draw tube. The new collet can then be screwed onto the draw tube and the whole replaced in the spindle. Tension is set on the collet by means of the adjusting sleeve. The tension must be tested by means of the hand lever, care being taken to ensure that excessive pressure is not required to close the collet. A spring compensator is included in the toggle mechanism to accommodate any small variations in bar size. If the machine is run without collets and tubes, the collet adjusting sleeve must be removed from the spindle.

The feed fingers are fitted to feed tubes which carry on their outer ends the bar feed bobbins, the outer parts of which are formed by shielded anti-friction bearings.

To remove the feed fingers it is first necessary to slide back the stock carriage tubes. This is done by first pushing the tube towards the machine and then turning anticlockwise until the head of the tube is free to slide back. By turning the plate on the rear of the centre stop which is held in position by a spring plunger, the feed tubes may be removed complete. To remove the feed tube in station 6, the bar feed shoe lever must also be moved to the down position. To remove the feed tubes in any station but station 6, when the automatic stop is fitted, the alignment fingers must be lifted clear. See Drg.100Z66.

Steady bushes are fitted in the end of the feed tubes and are retained by a screwed sleeve and nut.

5.9 Collet and Bar Feed Operation

The collet slide is operated in station 6 by cams through a lever and link. The pin at the top of the lever is eccentric. This enables the collet operating shoe to be lined up with the collet bobbins. It is initially set at the works and should not require adjustment. A stop rod and locknuts are provided to prevent the slide being moved further than is required.

A screw in the top of the collet operating slide acts as a backstop for the collet operating finger. By unclamping this screw and screwing it inwards, the collet operating shoe may be disengaged from the bobbins rendering the collet operating mechanism inoperative. The collet operating shoe is spring-loaded so that if a bobbin comes round out of position, the finger will be depressed preventing damage.

Hand operation of the collet is provided for checking adjustment, but can be used only while the cam roller is in the gap provided in the cams. The cam plate for the cam timing switch (Fig.5.5 drg.100Z84) should be kept set to trip the machine at this point.

The bar feed is operated by cams and springs through the bar feed lever and a link. The slide is fed forward by two compression springs and returned by cam. By means of the nuts on the spring connecting rod, the spring tension may be varied to suit requirements. The link to the bar feed slide is constructed so that it will collapse should the bar feed be prevented from returning under the action of the cam. Should this occur, the obstruction must be removed before resetting the link.

The bar feed stroke should be set before the bars are loaded into the machine. First handwind the machine until the bar feed slide is in the fully forward position. Loosen the centre stop and slide this as far back as it will go. If section 153 (the auto stop after completion of the bar) is fitted, the pusher plate and bracket and the aligning plate carrier must also be moved back. These are clamped on their rods by means of pad bolts. To move the pusher plate and bracket backwards, it may be necessary to lift it clear of the bar feed bobbin.

Next handwind the machine until the bar feed slide is in the fully back position, the centre stop should be set to its new position. If the auto stop is also fitted, the aligning plate carrier and the pusher plate and bracket should be reset. In this case the centre stop is set so that the back of the plate is in line with the bottom of the milled slot in the aligning plate carrier.

The stock carriage tubes may be adjusted to and from the spindle by releasing the head on the tube and reclamping in the desired position. This is desirable, when using small diameter bars, in order to give the maximum support to the bar.

If the stock carriage tubes have been set forward, they should be moved back before increasing the bar feed stroke and reset after completing the change.

When repositioning the centre stop on machines with the auto stop fitted, it may be set father back than as stated previously. This is useful when short feed stokes are set as it gives more available movement for forcing the new bar through the feed finger when loading. The centre stop should be set so that the bar feed tubes cannot wander backwards or foul the stock carriage tubes if these are adjusted forward.

Should it be necessary to change the bar feed stroke after the bars are loaded into the machine, all the collets should be opened before starting the above procedure. If the stroke is increased whilst bars are in the machine and the collets are not open, the aligning ring on the bar feed slide will have to return all the feed tubes at once and this extra load will cause the link to collapse. If the stroke is decreased when bars are in the machine, each bar feed tube must be set in the loading station until all six are in the new position; the centre stop can then be reset.

The bar feed shoe is spring-loaded and will be depressed should a bar feed bobbin index round when out of position.

5.10 Bar Stop

The bar stop arm is mounted on a shaft which passes through the drum housing and the cut-off slide base. It is clamped to this shaft by a pad bolt, the stud of which is extended to form the bar stop hand lever.

The bar stop itself is bolted to its bracket and may be turned round to accommodate long jobs.

It is operated by a cam with spring return through a lever, a link rod and a double lever. The link rod is extended to take a spring which will compress should any obstruction prevent the bar stop from operating under the force of the cam. The double lever carries a stop screw which is set against the stop pin when the bar stop is central to the bar. The nuts on the spring rod are then set $1/32"$ to $1/16"$ clear in this position. The above settings are used when the bar stop is in the up-swinging position.

It can be arranged to swing downwards by connecting the link rod to the second arm of the double lever. When used in this position, the stop pin must be placed in the second hole and the stop screw reversed. The nuts on the link rod may need readjustment after changing over. See fig.5.6. 100Z57A.

5.11 Centre Tool Block and Longitudinal Slides

The centre tool block slides on the nitrided centre guide and is fitted with scraper rings to prevent the ingress of swarf and coolant.

The longitudinal slides are mounted on bases attached to the underside of the beam.

The faces and tee slots are machined to close limits so that tool holders and attachments may be fitted to any face of the centre tool block or the the longitudinal slides without selection for height or centrality.

The centre block and longitudinal slides are operated by levers carried in the sliding block. The centre tool block is connected to its lever by a link, while the levers for longitudinal slides engage pusher bars which carry studs. The endwise position of the slides can be varied by means of nuts on these studs. The top ends of the levers in the sliding block are connected by links to the stroke setting blocks in the operating levers which are cam controlled from the upper camshaft.

The feed stroke is set by sliding the stroke setting blocks up or down the operating levers to the stroke indicated on the scale. The stroke setting blocks must be firmly clamped when set. The central lever controls the centre tool block and the side levers control their corresponding longitudinal slides.

It will be found easier to alter the feed strokes when the slides are in the fully forward position. The slide dead stops MUST be slackened off before altering the strokes and then reset.

The sliding block is operated by a cam controlled toggle mechanism. This provides the fast motion stroke which is constant, irrespective of the feed stroke. The forward stop for the sliding block is spring-loaded to eliminate any play in the toggle mechanism. The back stop for the toggle is set with slight clearance with the toggle roller on the peak of the return cam.

The feed to the centre tool block is taken by the centre guide arm. This is provided with a gib strip adjustment to eliminate play. Care must be taken when adjusting this to check on the extremes of stroke, as in normal running, wear will occur mainly on the portion covered by short strokes.

Gib strips are fitted to the dovetail slideways of the longitudinal slides.

The 4th & 5th longitudinal slides may be operated independently of the centre blocks by using auxiliary longitudinal slide motion, sec. 124D or 125D. In this case the operating lever for either or both 4th and 5th stations is carried on a fulcrum pin mounted on the beam. Being independent of the sliding block there is thus no fast motion available when these sections are used. A choice of two operating levers gives alternative strokes of $0 - 2 \frac{1}{2}$ (0 - 63.5 mm) or $\frac{5}{8} - 3 \frac{1}{2}$ (16 - 88.9 mm) using the standard cams. In special cases a longer stroke of $4 \frac{3}{4}$ (120.6 mm) may be obtained by using section 124A or 125A (Consult Wickman Bennett Ltd.).

5.12 Cross Slides Operation

The cross slides are operated by a mechanism similar to that operating the longitudinal slides.

The front and rear rocking levers are operated by a toggle mechanism, the front toggle lever being connected by a link with the rear toggle lever which is cam controlled. The effective length of the link is set at the front by means of an eccentric pin to give the correct offset of the front operating toggle. Spring-loaded stops are provided under the rocking levers to eliminate play in the toggles.

The feed stroke on any cross slide may be set independently by sliding the block of the operating link along the rocking lever tee slot. The feed stroke is indicated on a scale. The cross slide stop should be slackened off before adjusting the feed stroke and reset afterwards. The feed strokes are more easily set if the cross slides are in the fully forward position.

The mechanism gives an approximately constant forward position at the end of the feed stroke to all cross slides for all feed strokes.

The cross slide stops are screwed into sleeves which are held in the brackets by pad bolts. This arrangement allows the sleeves to slip if excessive stop pressure is set.

The upper and lower cross slides may be adjusted to and from the work by releasing the square head set screw in the bracket at the end of the slide and turning the graduated knob.

The cross slides fitted to 3rd and 6th stations are each adjusted by slackening the nut on the top face of the slide and turning the graduated knob. Care must be taken to retighten the nut before handwinding or running the machine.

All cross slides are fitted with gib strips. The end shields must be removed to obtain access to the inner gib adjusting screw on the lower cross slides.

5.13 Coolant

The coolant pump is mounted in the machine tray at the rear of the machine at the stock carriage end. It is a motorised centrifugal pump with a pump delivery of 159 litres per minute when pumping cutting oil of high viscosity or 242 litres per minute when pumping soluble water based cutting oils. The pump is driven by a totally enclosed, fan cooled, flanged mounted, 3 phase, 1.5 kW electric motor.

The coolant is pumped from the machine tray via a strainer box to the coolant taps located under the lower cross slides and in the coolant header on either side of the top beam of the machine. The strainer box should always be kept clear of swarf and should always be fitted over the pump intake pipe.

A weir across the discharge end of the tray permits swarf to settle in the bottom of the tray.

5.15 Swarf Conveyor

This is fitted as an optional extra. It is of the screw type and is fitted beneath the drum housing and the end bracket, discharging the swarf beneath the stock carriage. Quickly detachable chutes are fitted in the tray between the main housings to guide the swarf into the conveyor.

There is a 5/32" 4mm diameter sliver steel shear pin in the coupling adjacent to the motor gearbox on the drive shaft. Before renewing a sheared pin the cause of overload must be located and corrected. Tommy bar holes are provided in the end of the conveyor screw so that it may be turned by hand. Spare shear pins are provided in the container secured to the side of the conveyor.

A basket is placed at the lower end of the conveyor which screens the small swarf held in suspension in the coolant. This basket must be emptied at regular intervals and not allowed to overflow.

5.16 Feed Trip and Auto Stop Mechanisms

A safety stop mechanism is incorporated additional to the hand feed clutch levers. This mechanism is operated automatically by:-

- (a) Disengagement of the feed slipping clutch.
- (b) The manual trip mechanism.
- (c) The auto stop mechanism, designed to operate when bar stock is exhausted in any spindle.
- (d) Safety switches incorporated in special tooling devices.

Manual Trip Mechanism

The manual trip switch mounted on the control panel door incorporates three functions, one of which is the manual control to stop the machine at the end of cycle. It is a three position rotary selector switch which selects the following functions:- "production run", "set up" and "stop at the end of cycle. The switch prepares the electrical circuits to permit the machine to (a) run in the continuous mode until bar exhaustion occurs, (b) to operate without the coolant supply and the swarf conveyor; this is for setting purposes, and (c) stop at the end of cycle. Under this last condition the electrical circuit is prepared to operate in conjunction with a cam timing limit switch mounted adjacent to the camshaft operating the longitudinal slides. The action of the roller on the switch lever dropping into a notch in a cam plate mounted on the camshaft, operates the cam timing switch to stop the machine at the end of cycle with the collet open. The action of activating the cam timing limit switch de-energises the electro-magnetic feed clutch and the electro-magnetic feed brake to enable its brake springs to apply the braking pressure to brake and arrest the feed shaft. The circuit is also arranged to stop the main motor.

The Automatic Stop Mechanism (See Drg.100Z64A in the Operators Manual)

When each spindle indexes from the 5th station to the 6th station, the spring loaded plate (A) contacts the side of the feed tube bobbin bearing (B). If the feed finger is still gripping the bar, the plate is retained in position and the machine continues to operate normally. If the bar is used up and the feed finger is off the end of the bar, the spring loaded plate (A) will move $5/32$ " (3.97mm) towards the stock carriage under the action of the spring (N) and controlled by interaction of a roller carrier (Q) and its roller (R) against the cam cut on the face of the stock carriage support disc.

The spring loaded plate (A) is carried on a bracket (C) which is clamped to the trip shaft (D), the movement of which under the action of the spring (N) operates the trip and its face is in contact with the screw (F) which is screwed into the trip lever (G). This trip lever is pivoted about a pin (H) and carries at one end a tappet screw (J) which contacts the plunger of a limit switch (K). The tappet screw (J) is set to give $1/32$ " (0.8mm) clearance between its head and the switch plunger when the trip lever (G) and the latch plunger (L) are engaged.

On the operation of the mechanism, the switch plunger is activated by the movement of the trip lever (G) and prepares an electrical circuit, so that when the cam timing switch mounted adjacent to the longitudinal slides operating camshaft is operated by its camshaft mounted cam at the point in the cycle when the collet is open, the electro-magnetic feed clutch and brake is de-energised allowing the brake springs to arrest the feed shaft. The circuit is also arranged to stop the main motor.

Plate 100Z64A shows a scrap view of the position of the tappet screw (J) with the plunger (L) in engagement with the trip lever (G) when the automatic stop mechanism has been activated by bar exhaustion. The plunger (L) acts as a latch to hold the tappet screw (J) off the limit switch plunger when the trip lever is operated.

Before commencing to load new bar, the bar feed shoe lever must be moved into the down position and the bar end removed. Collet tension should be checked by hand for each new bar.

After the new bar has been loaded, the bar feed shoe lever must be moved to the "up" position with the bar feed shoe engaging the bearing on the feed tube bobbin, the main motor should be restarted. The plunger (L) must be released so that the trip lever (G) takes up its normal position before operating the "feed start button".

A signal lamp on the control panel is illuminated when the machine stops under the action of this mechanism.

The mechanism may be rendered inoperative by pulling back the plunger (L) and retaining it by turning the stop (P). This prevents the continual tripping of the machine when setting up without the feed tubes. For setting the brake interlock limit switch see the Operators Handbook.

The spring loaded plate (A) in conjunction with the lever (M) permits the plate (A) and its bracket (C) to move acutely if the spindle drum indexes with the feed tube bobbin bearing out of its linear position. This is purely a safety feature.

Feed Slipping Clutch

A limit switch is mounted behind the feed slipping clutch. It is normally set to clear the clutch body, but to be operated when the clutch moves out of engagement with the feed/fast motion shaft driving gear. The switch when operated de-energises the electro-magnetic feed clutch and brake, thus allowing the brake springs to arrest the feed shaft. The electrical circuit is also arranged to stop the work spindles when the feed slipping clutch disengages.

5.17 Double Bar Feed Machine

This machine is arranged to bar feed in 3rd and 6th stations. The bar feed operation and collet operation are duplicated on the front and rear of the machine.

The bar feed at the rear is operated by the bar feed lever at the front. The bracket to which the link is connected on the rear bar feed slide is adjustable so that jobs of different lengths can be produced up to a maximum of 1" (25.4mm) difference. A scale is provided on the bracket which is set to the difference between the bar feed lengths required. The longer job must always be set on the front bar feed slide. Where the two jobs are equal in length, the scale is set at 0.

The rear collet slide is operated by an independent lever from its own cams.

The jobs are parted off the bar in stations 3 and 6, cut-off slides being provided in both stations. Bar feed occurs after the feed stroke immediately before indexing.

The bar stop, fitted in station 3, is operated from cams on the spare cam disc in the drum housing. This excludes the use of the auxiliary cross slide motions, Sections 193, 193A, 193B, and 193C. The auto stop is fitted as standard. Duplicate unites are fitted to operate in both stations. Indicator lamps in the top of the control panel light up if the bar has been completed. The lamps are situated one behind the other and so indicate in which station the bar is completed.

The double feeding machine can be operated as a single feeding machine after making the following adjustments:-

1. Remove the rear bar feed shoe, complete with spring and plunger.
2. Set the same bar feed stoke on the rear as set on the front.
3. Retain the rear collet operating finger clear of the collet bobbins by means of the plunger.
4. Remove springs (N) from lower auto stop mechanism. This will render the mechanism inoperative. The upper auto stop mechanism must not be altered.
5. Take off the rear bar stop.

5.18 Spindle Stopping Machine

When very large quantities of components are to be produced, requiring one or more secondary cross operations such as cross drilling, reaming, milling, sawing, tapping etc, the Wickman 1" 6-Spindle Machine can be supplied with spindle stopping mechanism. Provision for fitting this mechanism is, however, not made in normal machines and must be provided at an early stage of initial manufacture.

An entirely special spindle drum is used and each spindle runs on a precision parallel roller bearing at the front and a pair of 'face to face' preloaded angular contact ball bearings at the rear, enclosed in a flanged housing.

5.19 Special Speed and Feed Chart

Different ratio spindle drive gears are used on the spindle stopping machines, and different speed and feeds and attachments ratios and gears are therefore available, details of which are given on the chart and on the appropriate attachment gear charts.

Each spindle gear is driven from the central gear and runs loosely on ball and roller bearings when the multi-plate brake is engaged.

The brake is non-adjustable, as a series of preloaded cushion springs are provided to limit and maintain the torque, which is sufficient to brake the spindles rapidly to a standstill.

The multi-plate clutch on each spindle is engaged by the axial thrust developed by a row of balls, squeezed inward against conical and flat faces by the clutch bobbin, when it is shifted by the cam-operated clutch glut. The clutch is adjusted by turning the slotted locknut from serration to serration on its RIGHT HAND thread, the serrations being maintained in engagement by the clutch plate separating springs. The clutch is accessible for adjustment in 6th Station, and an adjustment of one serration at a time can easily be made by a sharp hammer blow on a suitable punch. After each adjustment each clutch must be checked by levering the glut into and out of engagement, so as to ensure that the adjustment is not too tight and that the glut pressure is not so excessive as to cause overheating or a jam. The glut should be levered by inserting a suitable bar through the hole in the fulcrum bracket which is provided in the drum housing. The inner end of the bar should be levered against the roller on the glut. The clutch gluts are operated in turn during indexing of the spindle drum by a suitable series of cams secured in the cam recess around the drum housing bore. The cams may be selected to suit varying tooling conditions and are supplied to order. Access to the cams is provided through cored openings at front and rear of the machine, on opening the drum housing doors, and also at the top of the drum housing by removing the covers.

When fitting new cams, care must be taken by hand winding through index, that the glut cam rollers pass freely all round the cam track.

A start cam 102V218 is fitted as standard in station 1 to ensure that the spindle clutches do not gradually disengage on machines which are used without stopping the spindles in any station. The cam also ensures that the clutches are engaged, if left inadvertently in the brake position during hand testing of the clutch tension. If cams are fitted to stop the spindles in station 1, cam 102V128 is supplied loose with the machine, and should be fitted in position when the above stopping cams are removed on change of set-up.

The cam roller for each glut runs on an eccentric roller pin which is secured in its glut by a dog-point screw during building, after being adjusted so as to ensure that all clutch bobbins have an equal amount of overtravel. When a spindle clutch is engaged by its cam on hand-winding through index, the edge of the bobbin should be in line with the turned groove in the serrated ring. The collet closing bobbin and its associated parts at the rear of each spindle are identical with the standard machine.

5.20 Special Capacity Charts

Except on early machines, on which tool slide capacity dimensions are the same as on the standard machine, all machines fitted with the spindle stopping mechanism have the upper cross slide at 30 deg to the vertical, and the special capacity chart applies. This arrangement makes possible several consecutive cross operations with the spindle remaining stopped.

Cross slide attachments and their drives for use on spindle stopping machines are usually designed for a special and relatively limited application, sometimes on special slides, and requirements should be referred to Wickman Limited.

5.21 Dismantling

If it should be necessary to dismantle a spindle, this should be done in 6th station. The clutch glut can be removed after extracting the glut rod from the back. Then the collet closing tube and bobbin assemblies should be removed, followed by the rear bearing locknut.

The rear bearing cover can then be removed and the rear bearing assembly may be extracted by means of screws through the flange, or by a specially made long extractor applied at the end of the spindle.

With the centre tool block in the fully returned position, the front bearing cap and piston ring retainer can be detached and the spindle carefully removed. A circlip is provided to retain all parts on the spindle.

When reassembling, care should be taken to align the brake housing keyway with the torque pin. When tightening the rear bearing locknut, the clutch should be disengaged. The piston ring retainer should be placed carefully over the piston ring, followed by the bearing cap.

5.22 Stock Carriage

The two main parts, the stand and the tube assembly, are erected and aligned as described in the Operator's Handbook. The tube assembly has a central tube to which are secured two tube carriers to space and guide the stock tubes. The rear carrier is supported on rollers in the stock carriage stand.

At the machine end, the front carrier is gear driven during indexing by a pinion from the drum indexing mechanism and must be correctly meshed to the marks on the gears. The stock tubes are located ~~by a~~ by a flanged sleeve secured to each tube and clamped in pairs to the front carrier.

The tubes should be handled carefully; bent or distorted tubes will make it more difficult to slide the tubes through the carriers.

5.23 Clutch Adjustment

Both sides of the clutch should be adjusted to give a satisfactory non-slip drive in the 'ON' & 'OFF' positions. The serrated cam disc should be tapped around a serration at a time using a flat ended punch and hammer. To increase the driving power, rotation should be clockwise looking from the centre of the clutch towards the clutch plates. The glut spring should be removed and the clutch tested by levering with a bar between the main drive housing opening and the operating glut. When the clutch is operated from a mid position, the sliding bobbin should first move easily, then build up resistance to a maximum just as the plates compress together and the ease slightly as the internal toggles move over their high point. Set the minimum adjustment to obtain this feel without obtaining clutch slip or overheating. The clutch is a wet type and requires a good oil supply to the plates.

Clutch Dismantling (Servicing or Overhaul Purposes)

This is straight forward except for the removal of the operating bobbin which must be moved endwise after removing the clutch plates and the adjustment assemblies, rotated through 60 degs. and again moved endwise off the inner member to allow three of the six operating pins to pass the toggles. Reverse the procedure to re-assemble.

Maintenance Notes.

SECTION SIX - PARTS LISTS AND GENERAL ARRANGEMENTS

Drg No.101Z1B Spindles

1.	101X172	Key
2.	154/03	3/16" Spring Washer
3.	156/206	2 B.A. Socket Head Cap Screw 3/8" long.
4.	101X170	Stop Plate Bolt
5.	188/0740	7/16" B.S.F. square Head Set Screw 2.1/4" long
6.	143/0812B	1/4" dia. Grooved Pin 3/4" long.
7.	101X171	Key
8.	101Y168	Feed Tube Steady
9.	154/06	3/8" Spring Washer
10.	155/0624	3/8" B.S.F. Socket Head Cap Screw 1.1/2" long.
11.	101Z101B	Spindle Drum
12.	101X146A	Locator
13.	155/0516	5/16" B.S.F. Socket Head Cap Screw 1" long.
14.	154/05	5/16" Spring Washer
15.	122V212	Drum Seal
16.	143/0408D	1/8" dia. Grooved Pin 1/2" long.
17.	118X161	Washer
18.	101X160	Centre Spindle Bearing Outer Spacer
19.	101X136C	Centre Driving Gear
20.	203/16L	1" B.S.F. Pinnacle Nut
21.	101X161A	Centre Bearing Outer End Spacer
22.	257/35	Ball Journal 35 x 80 x 21mm
23.	104/38P	Internal Circlip 80mm dia.
24.	121/1236T	3/8" Square Key 2.1/4" long.
25.	101Y165A	Centre Bearing Outer End Spacer
26.	154/06	3/8" Spring Washer
27.	155/0620	3/8" B.S.F. Socket Head Cap Screw 1.1/4" long.
28.	129/24	Welch Plug Washer 1.3/4" dia.
29.	181/0410	1/4" B.S.F. Socket Set Screw Taper Point 5/8" long.
30.	101X122B	Compensating Washer
31.	101X127B	Thrust Ring
32.	101X105	Pin for Toggle
33.	101V104C	Toggle
34.	101X106A	Pin for Toggle Roller
35.	101X107A	Roller for Toggle
36.	SP41E	Tab Washer
37.	101X267A	Retaining Screw
38.	155/0414	1/4" B.S.F. Socket Head Cap Screw 7/8" long.
39.	154/04	1/4" Spring Washer
40.	203/06L	3/8" B.S.F. self Locking Hexagon Nut.
41.	101X282	Threaded Taper Pin
43.	577X126	Knob
44.	577X125	Plunger
45.	577X123	Plunger Housing
46.	558X128	Spring
47.	101Y169A	Stop Plate
48.	101X152A	Binding Nut
49.	101X174	Locknut
51.	101X132C	Bar Feed Sleeve (Assembly No. 101X157B)
52.	258/40SS	Ball Journal 40 x 80 x 18mm
53.	101X175	Locknut
54.	153/04	3/32" Soft Pad
55.	176/0404	1/4" B.S.F. Socket Set Screw Cup Point 1/4" long.
56.	101X130B	Support Bush for Feed Tube
57.	101V272A	Adjusting Sleeve
58.	101X278	Plunger
59.	125/1008	5/32" dia. Taper Pin 1/2" long.

60.	101X273B	Collet Tube Sleeve
61.	101X275A	Spring
62.	101Y110C	Carrier for Toggle
63.	101Y111C	Toggle Operating Sleeve
64.	101X176A	Key in Spindle (Toggle Carrier)
65.	162/406	4 B.A. Countersunk Screws
66.	122/1032T	Parallel Key 5/16" x 7/32" x 2" long
67.	151/50	50mm Slotted Locknut
68.	153/05	Soft Pad 1/8" long
69.	176/0506	5/16" B.S.F. Socket Set Screw Cup Point 3/8" long
70.	101X124	Rear Bearing End Spacer
71.	101X121	Binding Cap for Spindle Gears and Bearing
72.	101Y109	Index Gear
73.	141/8	13/32" dia. Taper Pin 2.1/4" long
74.	SB.20	Special Bearing
75.	101X163A	Thrust Block.
76.	155/0728	7/16" B.S.F. Socket Head Cap Screw 1.3/4" long
77.	154/07	7/16" Spring Washer
78.	101X123	Rear Bearing Inner Spacer
79.	101X120A	Rear Bearing Outer Spacer
80.	143/0408D	1/8" dia. Grooved Pin 1/2" long
81.	104/40P	Internal Circlip 90mm
82.	101X112A	Spindle Gear
83.	122/1024T	Parallel Key 5/16" x 7/32" x 1.1/2"
84.	101X155B	Feed Tube (Assembly 101V158)
85.	101X154B	Collet Tube
86.	101Y102E	Work Spindle
87.	153/05	Soft Pad 1/8" long
88.	176/0506	5/16" B.S.F. Socket Set Screw Cup Point 3/8" long
89.	151/55	55mm Slotted Locknut
90.	101X119	Inner Spacer Front Bearing
91.	101X118	Outer Spacer Front Bearing
92.	101X522	Front Bearing Inner Spacer
93.	101X522	Front Bearing Centre Spacer (Outer)
94.	143/0406D	1/8" dia. Grooved Pin 3/8" long
95.	SB.19	Special Bearing
96.	101X153	Labyrinth Ring
97.	155/0524	5/16" B.S.F. Socket Head Cap Screw 1.1/2" long
98.	154/05	5/16" Spring Washer
99.	101X148A	Driving Key (for Collet)
100.	-	Solid Spring Collet
101.	-	Solid Spring Feeder
102.	101X147A	Spindle Nose
103.	101V114D	Binding Cap
104.	101X279A	Ring Housing
105.	101X280	Sealing Ring
106.	153/04	3/32" Soft Pad
107.	176/0405	1/4" B.S.F. Socket Set Screw Cup Point 5/16" long.
108.	101X156A	Stop Screw
109.	101X281	Piston Ring
110.	101Y108C	Centre Guide
111.	101Y164C	Centre Driving Shaft
112.	122V211	Seal Ring
113.	159/212	2BA DC/SK Head Screw x 3/4" long.

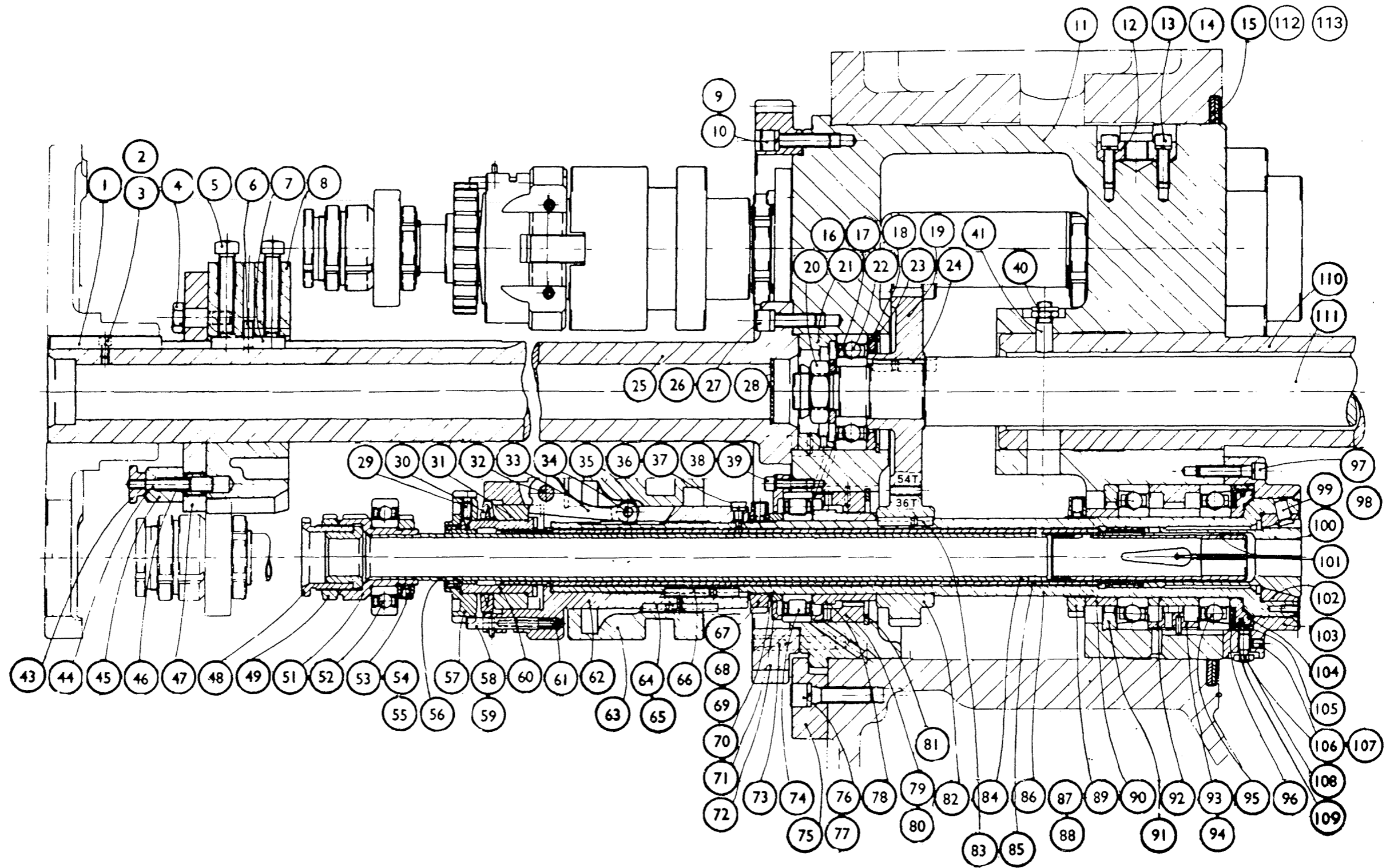

101 Z 1B SPINDLE

Drg No.102Z1B Spindle Stopping Drum

1.	101X172	Key
2.	156/206	2BA Socket Head Cap Screw 3/8" long
3.	154/03	3/16" Spring Washer
4.	101X170	Stop Plate Bolt
5.	188/0736	7/16" B.S.F. Square Head Set Screw 2.1/4" long
6.	143/0812B	1/4" dia. Grooved Pin 3/4" long.
7.	101X171	Key
8.	101Y168	Feed Tube Steady
9.	154/0624	3/8" B.S.F. Socket Head Cap Screw 1.1/2" long
10.	154/06	3/8" Spring Washer
11.	102Z101C	Spindle Drum
12.	101X146A	Locator
13.	155/0516	5/16" B.S.F. Socket Head Cap Screw 1" long.
14.	154/05	5/16" Spring Washer
15.	122V212	Drum Seal
15A	159/212	2BA Countersunk Screw 3/4" long
16.	203/1GL	1" Pinnacle Nut
17.	101X161A	Outer End Spacer for Centre Bearing
18.	143/0408D	1/8" dia. Mills Grooved Pin 1/2" long
19.	118X161	Washer
20.	257/35	Ball Journal Bearing (Medium Metric) 35 x 80 x 21mm
21.	101X160	Outer Spacer for Centre Spindle Bearing
22.	104/38P	80mm dia. External Circlip
23.	102X136B	Centre Driving Gear
24.	121/1236T	Key 3/8" Square 2.1/4" long.
25.	101X282	Threaded Taper Pin
26.	203/06L	3/8" B.S.F. Self Locking Nut
27.	101Y164B	Centre Driving Shaft
28.	101Y108C	Centre Guide
29.	101Y165A	Driving Coupling
30.	154/06	3/8" Spring Washer
31.	155/0620	3/8" B.S.F. Socket Head Cap Screw 1.1/4" long
32.	129/24	1.3/4" dia. Welch Plug Washer
33.	159/406	4BA C'sk Socket Head Screw 3/8" long
34.	102X191C	Driving Clutch Key
35.	101X154B	Collet Tube
36.	102X197C	Brake Housing Key
37.	158/406A	4BA C'sk Socket Head Screw 3/8" long
38.	102X190B	Brake Clutch Key
39.	102X199A	Brake Spring
40.	102X220	Inner Brake Spring
41.	102X197C	Brake Housing Key
42.	101X155B	Feed Tube
43.	182/0410	1/4" B.S.F. Socket Set Screw (Taper Point) 5/8" long
44.	101X122B	Compensating Washer
45.	101X127B	Thrust Ring
46.	101X105	Pin for Toggle
47.	101V104C	Toggle
48.	101X106	Pin for Toggle Roller
49.	101X107	Roller for Toggle
50.	154/04	Soft Pad 6 Swg. x 3/32" long
51.	101X267A	Retaining Screw
52.	SP41E	Tab Washer
53.	155/0416	1/4" B.S.F. Socket Head Cap Screw 1" long
54.	102X146	Bronze Dowel
55.	577X126	Knob
56.	577X125	Plunger

57.	577X123	Plunger Housing
58.	558X128	Spring
59.	101Y169A	Stop Plate
60.	101X152A	Binding Nut
61.	101X175	Locknut
62.	-	Supplied by Tooling
63.	101X132C	Bar Feed Sleeve (Assembly 101X157B)
64.	58/4055	Ball Journal Bearing (Light Metric) 40 x 80 x 18mm
65.	101X175	Locknut
66.	153/04	Soft Pad 6 Swg. x 3/32" long
67.	176/0404	1/4" B.S.F. Socket Set Screw 1/4" long
68.	101X130B	Support Bush for Feed Tube
69.	101V272A	Adjusting Sleeve
70.	101X278	Plunger
71.	125/1008	5/32" dia. Taper Pin 1/2" long
72.	101X273B	Collet Tube Sleeve
73.	101X275A	Spring
74.	101Y110C	Carrier for Toggle
75.	101Y111C	Operating Sleeve
76.	101X176A	Key for Toggle Carrier
77.	159/406	4BA C'sk Socket Head Screw 3.8" long
78.	122/1032T	Key 5/16" x 7/32" x 2"
79.	153/05	Soft Pad 3 Swg. x 1/8" long
80.	176/0506	5/16" Socket Set Screw 3/8" long
81.	151/50	50mm dia. Slotted Locknut
82.	102X124	Rear Bearing End Spacer
83.	102X121B	Binding Cap (Spindle Rear Bearing)
84.	141/8	13/32" dia. Taper Dowel 2.1/4" long
85.	102Y109	Index Gear
86.	SB28	Special Bearing A.C.
87.	101X163A	Thrust Block
88.	102X133A	Centre Spacer
89.	102/33	3.1/4" dia. Internal Circlip
90.	102X117B	Centre Spacer
91.	SB27	Special Bearing
92.	102X134A	Driving Clutch - Thrust Plate
93.	102X188A	Clutch Plate Inner
94.	102X193	Drive Thrust Plate
95.	102X184B	Clutch Adjusting Nut
96.	-	10mm dia. Steel Balls (20)
97.	102X189	Clutch Plate Outer
98.	102X198A	Brake Pressure Sleeve
99.	102X197C	Brake Housing Key
100.	SB87	Workspindle Bearing
101.	101X156A	Stop Screw
102.	153/04	Soft Pad 6 Swg. x 3/32" long
103.	176/0405	1/4" B.S.F. Socket Set Screw 5/16" long
104.	154/07	7/16" Spring Washer
105.	155/0728	7/16" B.S.F. Socket Head Cap Screw 1.3/4" long
106.	102X135	Bearing Housing
107.	101/22P	2" dia. External Circlip
108.	SB27	Special Bearing
109.	102X159A	Centre Spacer, Middle Bearing - Inner
110.	102V186A	Clutch Cup (and Spindle Gear)
111.	102X189	Clutch Plate Outer
112.	102X192A	Separating Spring
113.	508X248	Clutch Spring Pin

114.	102X183C	Clutch Thrust Sleeve
115.	102X182A	Clutch Centre Sleeve
116.	102X181A	Clutch Closing Sleeve
117.	FX.2466	Clutch Plate
118.	102X196C	Brake Housing
119.	-	2.7/8" External Circlip
120.	102X153A	Labyrinth Ring
121.	102V114C	Binding Cap
122.	155/0524	5/16" B.S.F. Socket Head Cap Screw 1.1/2" long
123.	154/05	5/16" Spring Washer
124.	101X148A	Driving Key for Collet
125.	-	Supplied by Tooling
126.	-	Supplied by Tooling
127.	101X147A	Spindle Nose
128.	102X152C	Ring Housing
129.	101X281	Piston Ring
130.	102X280	Seating Ring
131.	103/31	60mm dia. External Circlip
132.	102Y102G	Workspindle
133.	122V211	Seal Ring

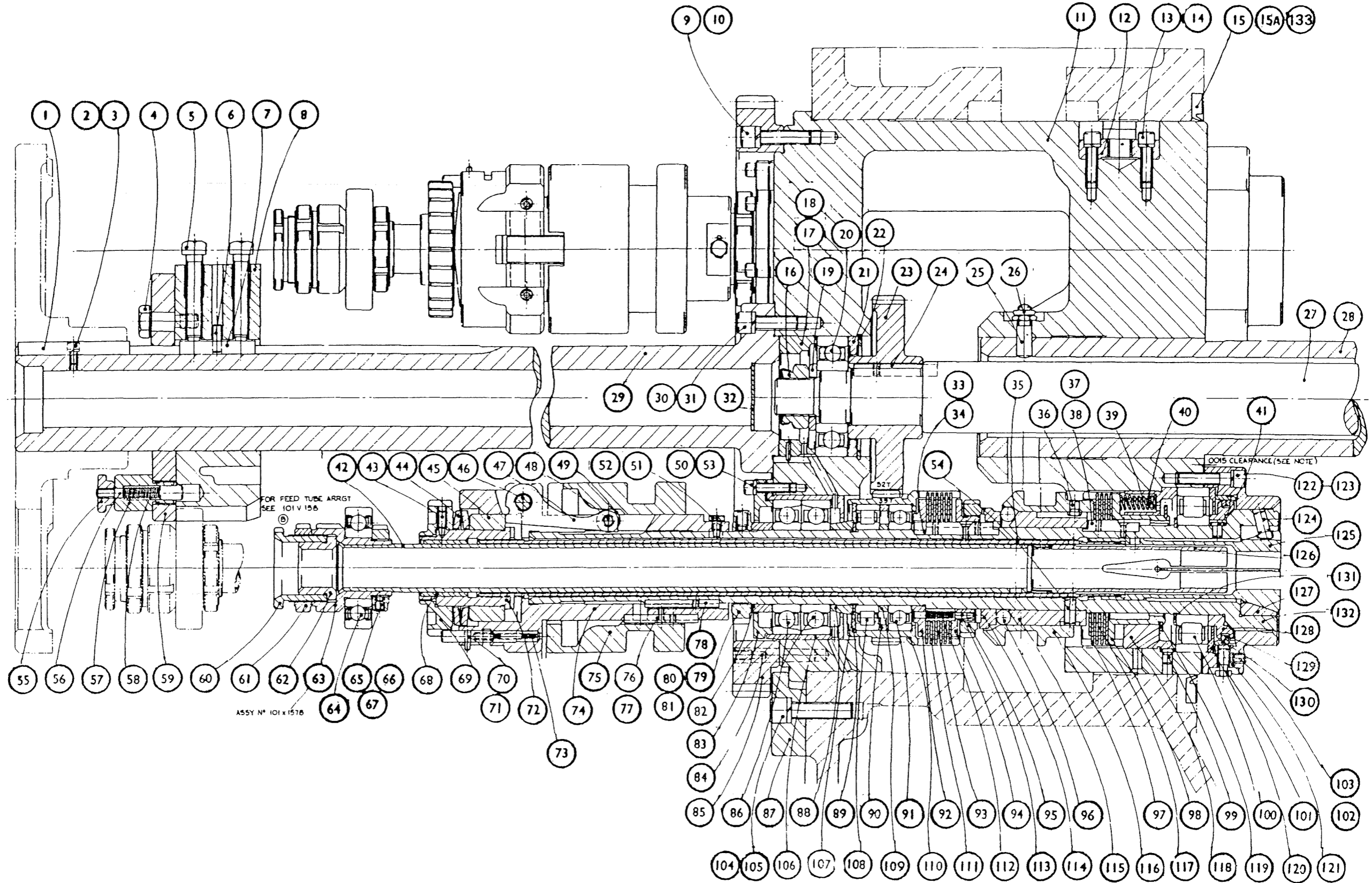

ASSY N° 101 x 157B

0.015 CLEARANCE (SEE NOTE)

Drg No.102Z2B ----- Spindle Stopping Drum

- | | | |
|-----|----------|--|
| 1. | 101X173 | Parallel Pin |
| 2. | 154/03 | 3/16" Spring Washer |
| 3. | 156/206 | 2 B.A. Socket Head Cap Screw 3/8" long |
| 4. | 158/0614 | 3/8" B.S.F. Countersunk Head Screw 7/8" long |
| 5. | 102V219 | Fulcrum Plate |
| 6. | 212/04 | Autolub Grease Nipple 1/4" B.S.F. |
| 7. | 141/4 | 11/32" dia. Taper Dowel 1.3/4" long. |
| 8. | 102X204A | Roller Pin |
| 9. | 102X203A | Clutch Glut Roller |
| 10. | 182/0420 | 1/4" B.S.F. Socket Set Screw (Taper Point) 1/4" long |
| 11. | 203/04 | 1/4" B.S.F. Simmonds Self Locking Nut |
| 12. | 102X205A | Glut Rod |
| 13. | 102Y202B | Clutch Glut |
| 14. | 203/04 | 1/4" B.S.F. Simmonds Self Locking Nut |
| 15. | 182/0414 | 1/4" B.S.F. Socket Set Screw (Taper Point 7/8" long |

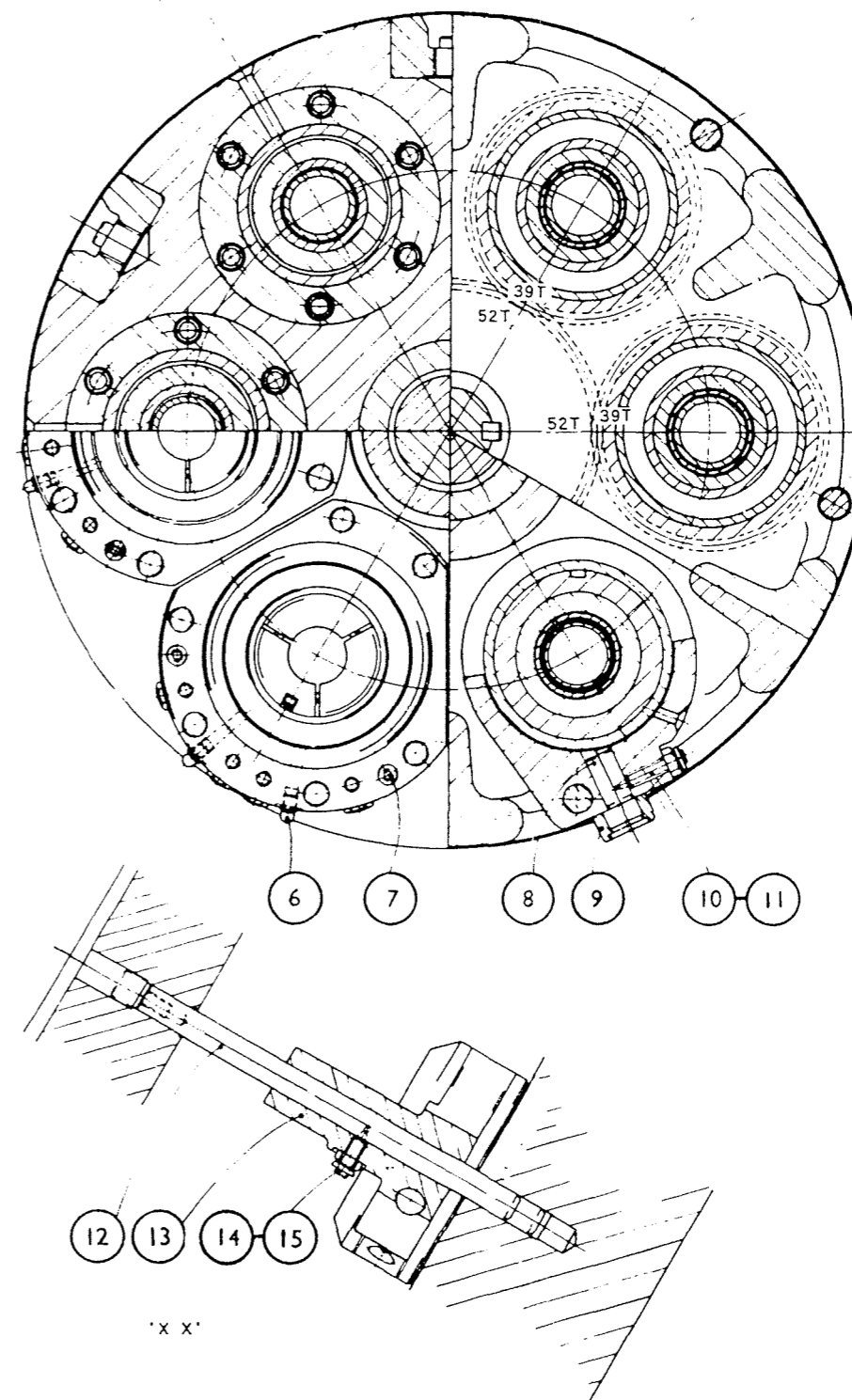
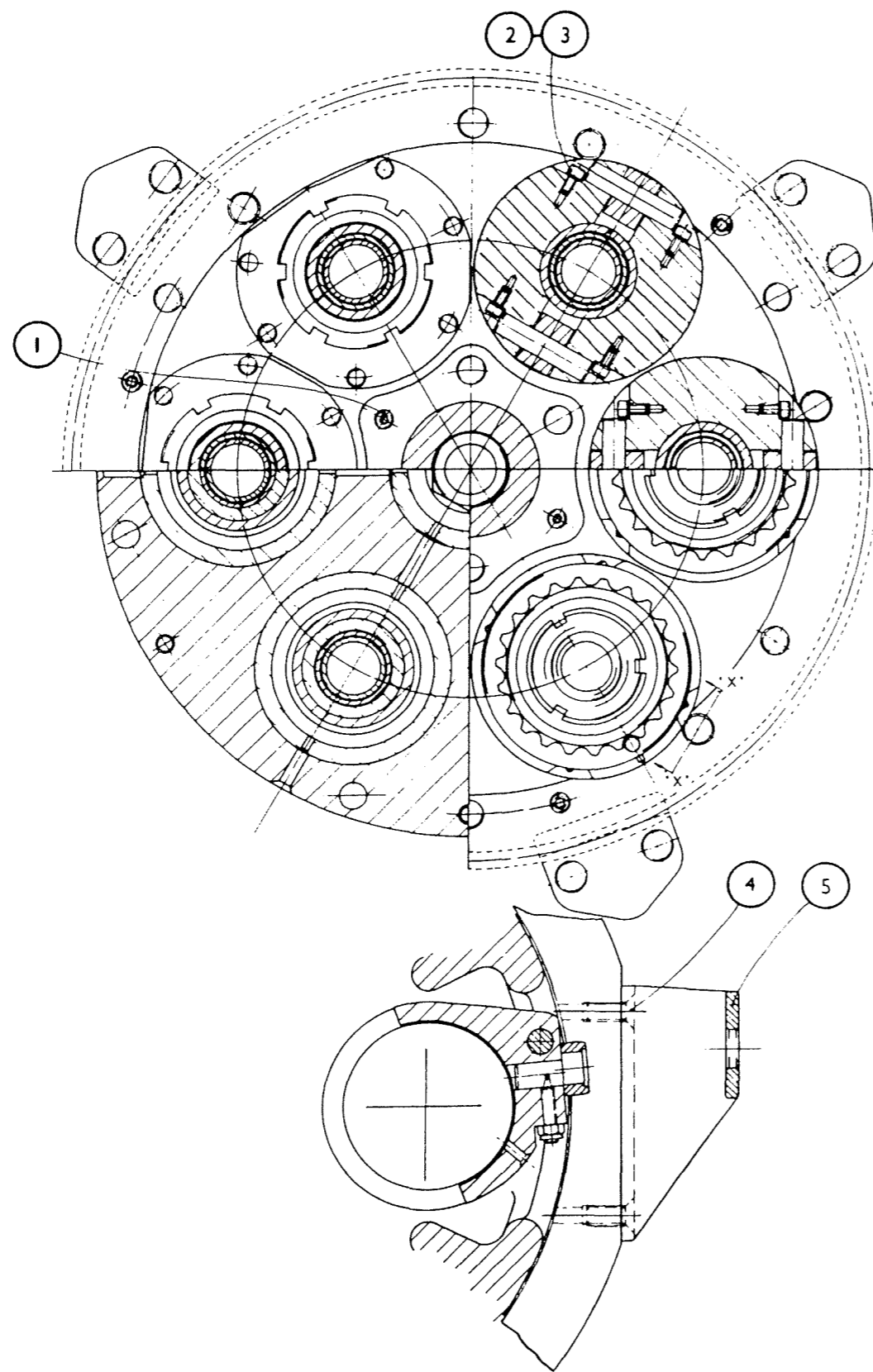

Drg No.102Z3C ----- Spindle Stopping Drum

- | | | |
|-----|----------|---|
| 1. | 102X225 | Cam (stop {3rd, 4th & 5th}) |
| 2. | 102X221 | Cam (stop {3rd, 4th & 5th}) |
| 3. | 102V222 | Cam (stop {3rd, 4th & 5th}) |
| 4. | 102V218 | Cam (stop 2nd, start 2nd, 4th, & {4th & 5th}) |
| 5. | 102V224 | Cam (stop 4th) |
| 6. | 102V218 | Cam (stop 2nd, start 2nd, 4th, & {4th & 5th})
Fit this cam as standard except when 1st station
is required. |
| 7. | - | Front face of housing |
| 8. | 102X208 | Cam (start 1st, 3rd & 5th) Start from 5th |
| 9. | 102X218 | Cam (stop 2nd, start 2nd, 4th & {4th & 5th})
Start from 2nd |
| 10. | - | Front face of housing |
| 11. | 102X207A | Cam (Stop 1st, start 4th) Start from 4th |
| 12. | 102V216 | Cam (Stop {1st & 2nd}, {1st, 2nd & 3rd}
{1st, 2nd, 3rd & 4th}, {2nd & 3rd} &
{2nd, 3rd & 4th}) |
| 13. | 102V217A | Cam (stop {1st & 2nd} {1st, 2nd & 3rd},
{1st, 2nd, 3rd & 4th} & {3rd & 4th}) |
| 14. | 102X215A | Cam (stop {1st, 2nd & 3rd} & {2nd & 3rd}) |
| 15. | 102V223 | Cam (stop 3rd & 5th) Stop 5th |
| 16. | 102V216 | Cam (stop {1st & 2nd, 3rd & 4th}, {2nd & 3rd}
& {2nd, 3rd & 4th}) |
| 17. | 102V217A | Cam (stop {1st & 2nd}, {1st, 2nd & 3rd},
{1st, 2nd, 3rd & 4th}, {2nd, 3rd & 4th},
& {3rd & 4th}) |
| 18. | 102X208 | Cam (start 1st, 3rd & 5th) Start from third |
| 19. | - | Front face of housing |
| 20. | 102X208 | Cam (start 1st, 3rd & 5th) Start from third |
| 21. | - | Front face of housing |
| 22. | 102V218 | Cam (stop 2nd, start 2nd, 4th & {4th & 5th})
Start from 2nd |
| 23. | 102X207A | Cam (stop 1st, start 4th) stop 1st. |
| 24. | 102V216 | Cam (stop {1st & 2nd}, {1st, 2nd & 3rd}
{1st, 2nd, 3rd & 4th}, {2nd & 3rd}, &
{2nd, 3rd & 4th}) |
| 25. | 102V217A | Cam (stop {1st & 2nd}, {1st, 2nd & 3rd}
{1st, 2nd, 3rd & 4th}, {2nd, 3rd & 4th}, &
{3rd & 4th}) |
| 26. | 102V217A | Cam (stop {1st & 2nd}, {1st, 2nd & 3rd}
{1st, 2nd, 3rd & 4th}, {2nd, 3rd & 4th}, &
{3rd & 4th}) |
| 27. | 102X226 | Cam (stop {3rd & 4th}) |
| 28. | 102V213 | Cam (stop {1st, 2nd, 3rd & 4th}, & {3rd & 4th}) |
| 29. | 102V217A | Cam (stop {1st & 2nd}, {1st, 2nd & 3rd}
{1st, 2nd, 3rd & 4th}, {2nd, 3rd & 4th}, &
{3rd & 4th}) |
| 30. | 102X208 | Cam (start {1st, 3rd & 5th}) Start from 1st. |
| 31. | - | Front face of housing |
| 32. | 102V218 | Cam (stop 2nd, start 2nd., 4th & {4th & 5th}).
Start from 4th. |
| 33. | - | Front face of housing |
| 34. | - | Spindle stops in station. |
| 35. | - | Cams required |
| 36. | - | Development |

- 37. 102V216 Cam (stop {1st & 2nd}, {1st, 2nd & 3rd} {1st, 2nd, 3rd & 4th}, {2nd & 3rd} & {2nd, 3rd & 4th}).
- 38. 102X215A Cam (stop {1st, 2nd & 3rd} & {2nd & 3rd}
- 39. 102V227 Cam (stop {4th & 5th})
- 40. 102V217A Cam (stop {1st & 2nd}, {1st, 2nd & 3rd} {1st, 2nd, 3rd & 4th}, {3rd & 4th}, & {3rd & 4th})
- 41. 102V222 Cam (stop {3rd, 4th & 5th})
- 42. 102X208 Cam (start 1st, 3rd & 5th)
- 43. - Front face of housing
- 44. 102X208 Cam (start 1st, 3rd & 5th). Start from 5th.
- 45. 102X208 Cam (start 1st, 3rd & 5th). Start from 3rd.
- 46. - Front face of housing
- 47. 102V216 Cam (stop {1st & 2nd}, {1st, 2nd & 3rd} {1st, 2nd, 3rd & 4th}, {2nd & 3rd} & {2nd, 3rd & 4th}).
- 48. 102V213 Cam (stop {1st, 2nd, 3rd & 4th} & {3rd & 4th})
- 49. 102V217A Cam (stop {1st & 2nd}, {1st, 2nd & 3rd} {1st, 2nd, 3rd & 4th}, {2nd, 3rd & 4th}, & {3rd & 4th})
- 50. 102V217A Cam (stop {1st & 2nd}, {1st, 2nd & 3rd} {1st, 2nd, 3rd & 4th}, {2nd, 3rd & 4th}, & {3rd & 4th})
- 51. - Front face of housing
- 52. 102V218 Cam (stop 2nd, start 2nd, 4th & {4th & 5th})
- 53. - Section "CC"
- 54. - Section "AA"

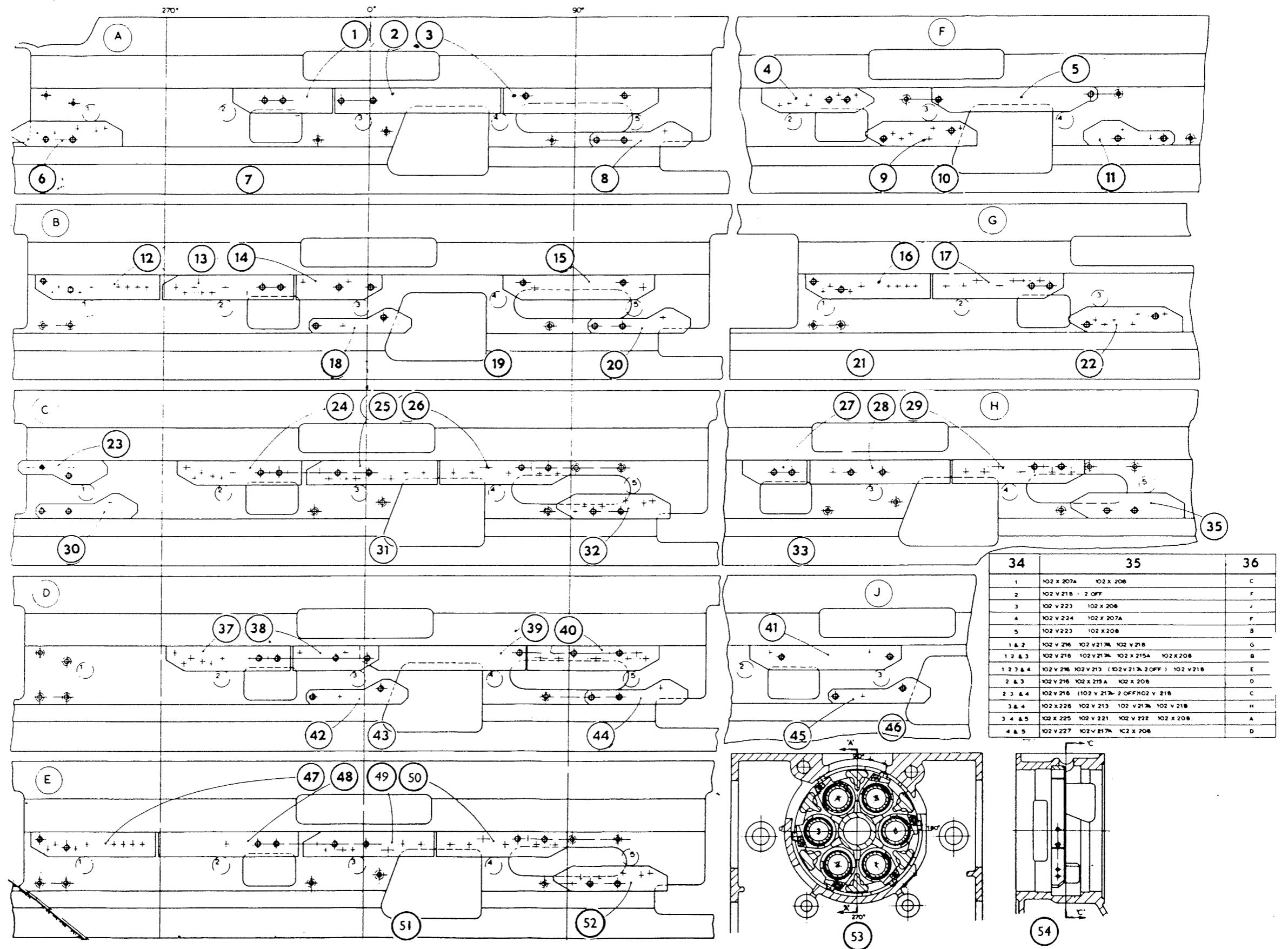

102 Z 3C

SPINDLE DRUM SPINDLE STOPPING

Drg No.116Z1D ----- Motor Drive

1.	122X124B	Backplate Extension, Section 122
2.	P/F084	1/4" B.S.F. Pinnacle Nut, Section 122
3.	167/0408	1/4" B.S.F. Head Set Screw, 1/2" long, Section 122
4.	116Y502B	Primary Shaft Pulley
5.	16Y502B	Motor Frame Size, Pulley No. Key
6.	167/0548	5/16" B.S.F Hex. Head Set Screw 3" long, Section 122
7.	122Y121	Belt Guard Back Plate
8.	30434	5/16" "Shakeproof" Lock Washer, section 122
9.	167/0548	5/16" B.S.F Hex. Head Set Screw 3" long, Section 122
10.	155/0612	3/8" B.S.F. Socket Head Cap Screw 3/4" long, Sec.122
11.	122X123A	Lower Belt Guard, Section 122
12.	167/0520	5/16" B.S.F. Hexagon Head Screw 1.1/4" long, Sec.122
13.	116X112	Stud
14.	N.P./F.204	5/8" B.S.F. Pinnacle Nut
15.	130/10	5/8" Flat Washer
16.	167/12112	3/4" B.S.F Hex. Head Set Screw, 7" Long
17.	116X113	Support Block
18.	155/0840	1/2" B.S.F Socket Head Cap Screw 2.1/2" Long
19.	-	See Table
20.	176/0610	3/8" B.S.F. Socket Set Screw Cup Point 5/8" long
21.	155/0696	3/8" B.S.F. Socket Head Cap Screw 6" long, Sec.122
22.	155/0406	1/4" B.S.F. Cap Screw x 3/8" long
23.	122V209A	Draught Deflector
25.	167/0828	1/2" B.S.F Hex Head Set Screw 1.3/4" Long
27.	116X510	Motor Packing Piece (Use with D160L Motor only)
28.	122Y122E	Belt Guard
29.	172X110A	Motor Direction Check Plate
30.	165/406	4BA Round Head Set Screw 3/8" long, Section 172.
31.	N.T./B044	4BA Pinnacle Nut, Section 172.
32.	155/0612	3/8" B.S.F. Socket Head Cap Screw 3/4" long

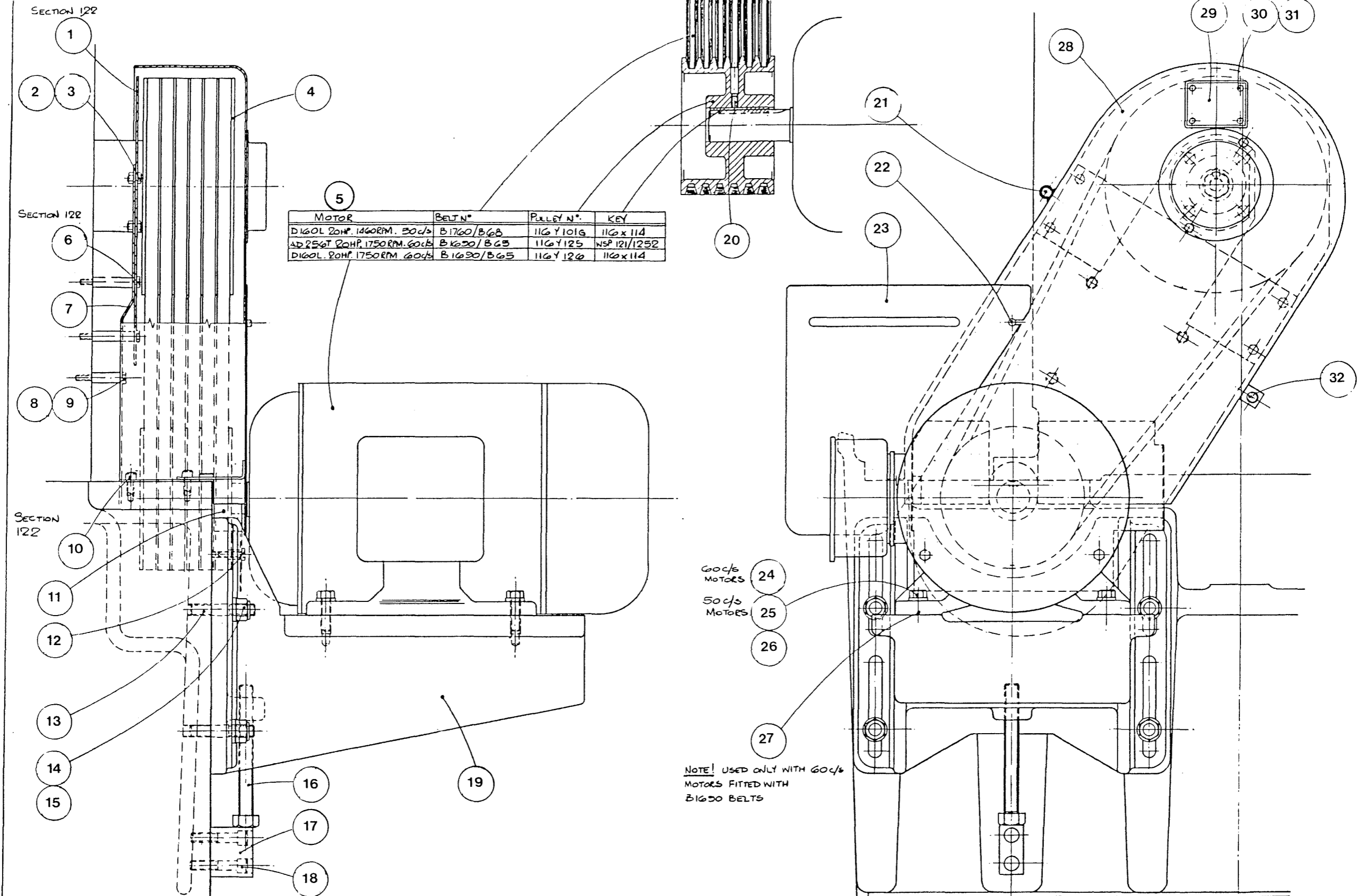

60c/s MOTORS 24
 50c/s MOTORS 25
 26

NOTE! USED ONLY WITH 60c/s MOTORS FITTED WITH B1650 BELTS

FIRST USED ON

LAST USED ON

SUPersedes 116Z1C

SUPerseded BY

ALTERATIONS

SEN 100 A 555

V & B LIMIT HOLES TO BS 184 1941

REMOVE ALL SHARP CORNERS UNLESS OTHERWISE STATED

TOLERANCE ON MACHINING DIMENSIONS & 0.01" UNLESS OTHERWISE STATED

AMERICAN PROJECTION

F = ROUGH MACHINE
 FF = FINISH MACHINE
 FF = GRIND OR EQUIVALENT

RAW MATERIAL NO.

MARK DRG. No AT @

DRG. No.

SCALE	HALF FULL	DRAWN	GC	19.2.80	MATERIAL	LOP
		CHECKED			116 L 18	
		TRACING				
		CHECKED				

No. OF ARRANGEMENT DRG. No. SECTION MACHINE

116 1-6 116Z1D

WICKMAN MACHINE TOOL MANUFACTURING CO. LTD.
 COVENTRY ENGLAND.

COPYRIGHT © THIS DESIGN AND DESIGN IS THE PROPERTY OF WICKMAN MACHINE TOOL MANUFACTURING CO. LTD. COVENTRY ENGLAND AND IS CONFIDENTIAL. IT MUST NOT BE LOANED, COPIED OR OTHERWISE COMMUNICATED TO A THIRD PARTY WITHOUT PERMISSION AND IS SUBJECT TO

DESCRIPTION

MOTOR DRIVE ARRANGEMENT.

PLFR1/6
 03/08/89

Frame 1, 6-Spindle Bar, Parts

Drg No.117Z1C ----- Main Drive Gearing

1.	101Y108	Centre Guide
2.	101Y164C	Centre Driving Shaft, section 101
3.	103/28	External Circlip 50mm dia.
4.	117X117A	Centre Guide Bearing
5.	104/40	Internal Circlip 90mm dia.
6.	117X115A	Centre Shaft Coupler
7.	117X110	Spacer
8.	117X114	Spacer (Medium)
9.	117X109A	Centre Shaft Spacer
10.	117X110	Spacer
11.	104/40	Internal Circlip 90mm dia.
12.	117X143	Bearing Sleeve
13.	258/50	Light Ball Journal 50mm x 90mm x 20mm
14.	117X107A	Sleeve Retainer
15.	155/0412	1/4" B.S.F. Socket Head Cap Screw 3/4" long
16.	154/04	1/4" Spring Washer
17.	103/28	External Circlip 50mm dia.
18.	117Y128B	Centre Drive Shaft
19.	101/18	External Circlip 1.1/2" dia.
20.	122/1228T	Key for Centre Drive Shaft
21.	117X110	Spacer
22.	257/40	Medium Ball Journal 40mm x 90mm x 23mm
23.	117X106	Bearing Housing
24.	155/0514	5/16" B.S.F. Socket Head Cap Screw 7/8" long
25.	-	See Table, Item 103
26.	104/40	Internal Circlip 90mm dia.
27.	159/210	2BA Socket Countersunk Head Screw 5/8" long
28.	117X185	Key for Change Gears
29.	117X116	"C" Washer
30.	117X119	Bolt
31.	117X105	Bearing Housing.
32.	104/38	Internal Circlip 80mm dia.
33.	103/23	External Circlip 40mm dia.
34.	159/210	2BA Socket Countersunk Head Screw 5/8" long
35.	117X185	Key for Change Gears
36.	117X116	"C" Washer
37.	117X119	Bolt
38.	-	See Table, Item 103
39.	121/1248T	Key for Primary Drive Shaft
40.	155/0514	5/16" B.S.F. Socket Head Cap Screw 7/8" long
41.	155/0516	5/16" B.S.F. Socket Head Cap Screw 1" long
42.	117X114	Spacer (Medium)
43.	154/05	5/16" Spring Washer
44.	117X150	Pulley Washer
45.	F244 Type T	3/4" B.S.F. Pinnacle Nut
46.	116X102B	Primary Shaft Pulley
47.	117X151	Pulley Spacer
48.	117X102B	Bearing End Cap
49.	W250/17550	Weston Oil Seal 2.1/2" o/d x 1.3/4" x 1/2" wide
50.	257/35	Medium Ball Journal 35mm x 80mm x 21mm
51.	117X101C	Bearing Housing
52.	117Y122B	Primary Drive Shaft
53.	117X202	Spacer
54.	155/0656	5/8" B.S.F. Socket Head Cap Screw 3.1/2" long
55.	154/06	5/8" Spring Washer
56.	110038	Renold Chain, 58 Links, Section 168
57.	F144 Type T	7/16" B.S.F. Pinnacle Nut

58.	130/07	7/16" Flat Washer
59.	168X133	Pump Sprocket, Section 168
60.	153/04	3/32" B.S.F. Soft Pad, Section 168
61.	176/0405	1/4" B.S.F. Socket Set Screw 3/32" long, section 168
62.	168X136	Pump Locknut, Section 168
63.	168X134A	Eccentric Bush, Section 168
64.	236/283228	Oil Retaining Bush 1.3/4" x 2" x 1.3/4" long
65.	258/40	Light Ball Journal 40mm x 80mm x 18mm
66.	117X135B	Fast Motion Gear
67.	118X141	Spring Retaining Plug
68.	317X111	Clutch Spring
69.	117X152	Plunger
70.	117Y104B	Slipping Clutch Body
71.	117X136	Slipping Clutch Centre
72.	117X112	Adjusting Washer
73.	117X120A	Slow Speed Drive Gear
74.	117X146A	High Speed Drive Gear
75.	257/30	Medium Ball Journal 30mm x 72mm x 19mm
76.	NT/F244 Type Y	3/4" B.S.F. Pinnacle Nut
77.	130/12	3/4" Flat Washer
78.	117X130A	Spacing Washer
79.	117X130A	Spacing Washer
80.	NT/F244 Type T	3/4" Pinnacle Nut
81.	130/12	3/4" Flat Washer
82.	257/30	Medium Ball Journal 30mm x 72mm x 19mm
83.	117X113A	Bearing Bush
84.	258/50	Light Ball Journal 50mm x 90mm x 20mm
85.	155/0516	5/16" B.S.F. Socket Head Cap Screw 1" long
86.	154/05	5/16" Spring Washer
87.	118X141	Spring Retaining Plug
88.	145/124	Sliding Gear Spring
89.	-	5/8" dia. Hardened Steel Ball
90.	117Y148A	Large Sliding Gear
91.	117Y125A	Speed Change Gear Shaft
92.	265/40	Light Double Row Ball Journal 40mm x 80mm x 23mm
93.	121/1228	Key for Small Sliding Gear
94.	117Y147A	Small Sliding Gear
95.	122/1240T	Key for Slipping Clutch Centre
96.	155/0544	5/16" B.S.F. Socket Head Cap Screw 2.3/4" long
97.	154/05	5/16" Spring Washer
98.	117X108	Thrust Washer
99.	117X505	Driving Sprocket
100.	121/0840T	Key for Primary Drive Shaft
101.	117X201	Coolant Pump Sprocket

117 Z 3

SEE 10121 & 2

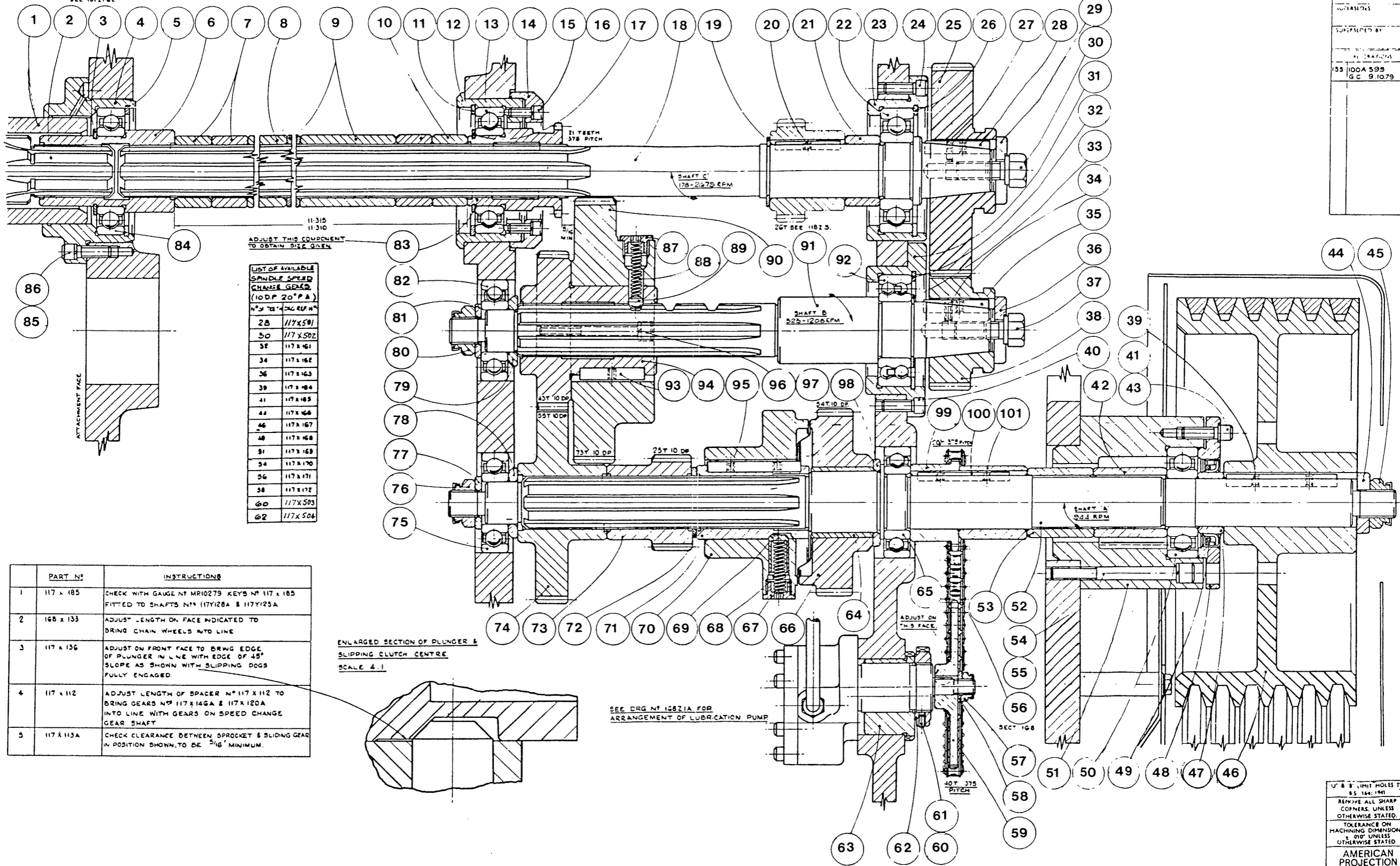

ADJUST THIS COMPONENT TO OBTAIN SIZE GIVEN

LIST OF AVAILABLE SPINDLE SPEED CHANGE GEARS (10 D.P. 20° P.A.)

Nº	TEETH	R.P.M.
28	117 x 501	
30	117 x 502	
32	117 x 461	
34	117 x 462	
36	117 x 463	
38	117 x 464	
40	117 x 465	
42	117 x 466	
44	117 x 467	
46	117 x 468	
48	117 x 469	
50	117 x 470	
52	117 x 471	
54	117 x 472	
56	117 x 503	
58	117 x 504	

PART Nº	INSTRUCTIONS
1	CHECK WITH GAUGE Nº M10279 KEYS Nº 117 x 185 FITTED TO SHAFTS Nº 117Y128A & 117Y125A
2	ADJUST LENGTH ON FACE INDICATED TO BRING CHAIN WHEELS INTO LINE
3	ADJUST ON FRONT FACE TO BRING EDGE OF PLUNGER IN LINE WITH EDGE OF 45° SLOPE AS SHOWN WITH SLIPPING DOGS FULLY ENGAGED
4	ADJUST LENGTH OF SPACER Nº 117 x 112 TO BRING GEARS Nº 117 x 146A & 117 x 120A INTO LINE WITH GEARS ON SPEED CHANGE GEAR SHAFT
5	CHECK CLEARANCE BETWEEN SPROCKET & SLIDING GEAR IN POSITION SHOWN TO BE 5/16" MINIMUM.

ENLARGED SECTION OF PLUNGER & SLIPPING CLUTCH CENTRE SCALE 4:1

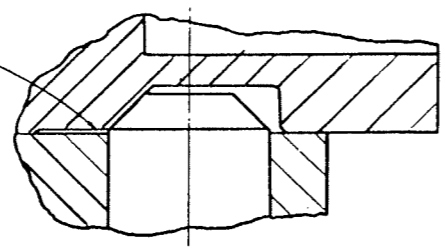

SEE DRG NO 10821A FOR ARRANGEMENT OF LUBRICATION PUMP

NEW STANDARD BUILD

FIRST USED ON BATCH
LAST USED ON BATCH
SUPERSEDED BY
REVISIONS
APPROVED BY
117 Z 3
100A 595
G.C. 9.10.79

WICKMAN MACHINE TOOL MANUFACTURING CO. L^{TD}. COVENTRY · ENGLAND.

CONFIDENTIAL - THIS DRAWING AND DESIGN ARE THE PROPERTY OF WICKMAN MACHINE TOOL MANUFACTURING CO. L^{TD}. NO PART OF THIS DRAWING OR DESIGN IS TO BE REPRODUCED OR TRANSMITTED IN ANY FORM OR BY ANY MEANS, ELECTRONIC OR MECHANICAL, INCLUDING PHOTOCOPYING, RECORDING, OR BY ANY INFORMATION STORAGE AND RETRIEVAL SYSTEM.

DESCRIPTION ARRANGEMENT OF MAIN DRIVE GEARING (STANDARD HIGH SPEED)

SCALE	DRAWN	CHECKED	TRACED	MATERIAL	DATE	BY	NO. OF	ARRANGEMENT	SECTION	MACHINE	MARK DRG NO. AT	DRG NO.
FULL SIZE	GC	11.10.79		L.G.P. REF. Nº 117 Z 3 A 46, 5, 6, 180 L 2A					117A	1-GP		117 Z 3

U & B LIMIT HOLES TO BS 184:1981
 REMOVE ALL SHARP CORNERS, UNLESS OTHERWISE STATED.
 TOLERANCE ON MACHINING DIMENSIONS ± 0.07 UNLESS OTHERWISE STATED.
 AMERICAN PROJECTION
 F = ROUGH MACHINE
 FF = FINISH MACHINE
 G = GRIND OR EQUIVALENT
 P.W. MATERIAL NO.

SEC 10/2/88

FIRST USED ON BATCH
LAST USED ON BATCH
DATE
SUPPLIER'S
NO. OF PARTS
33 100A 595
G.C. 9 10 79

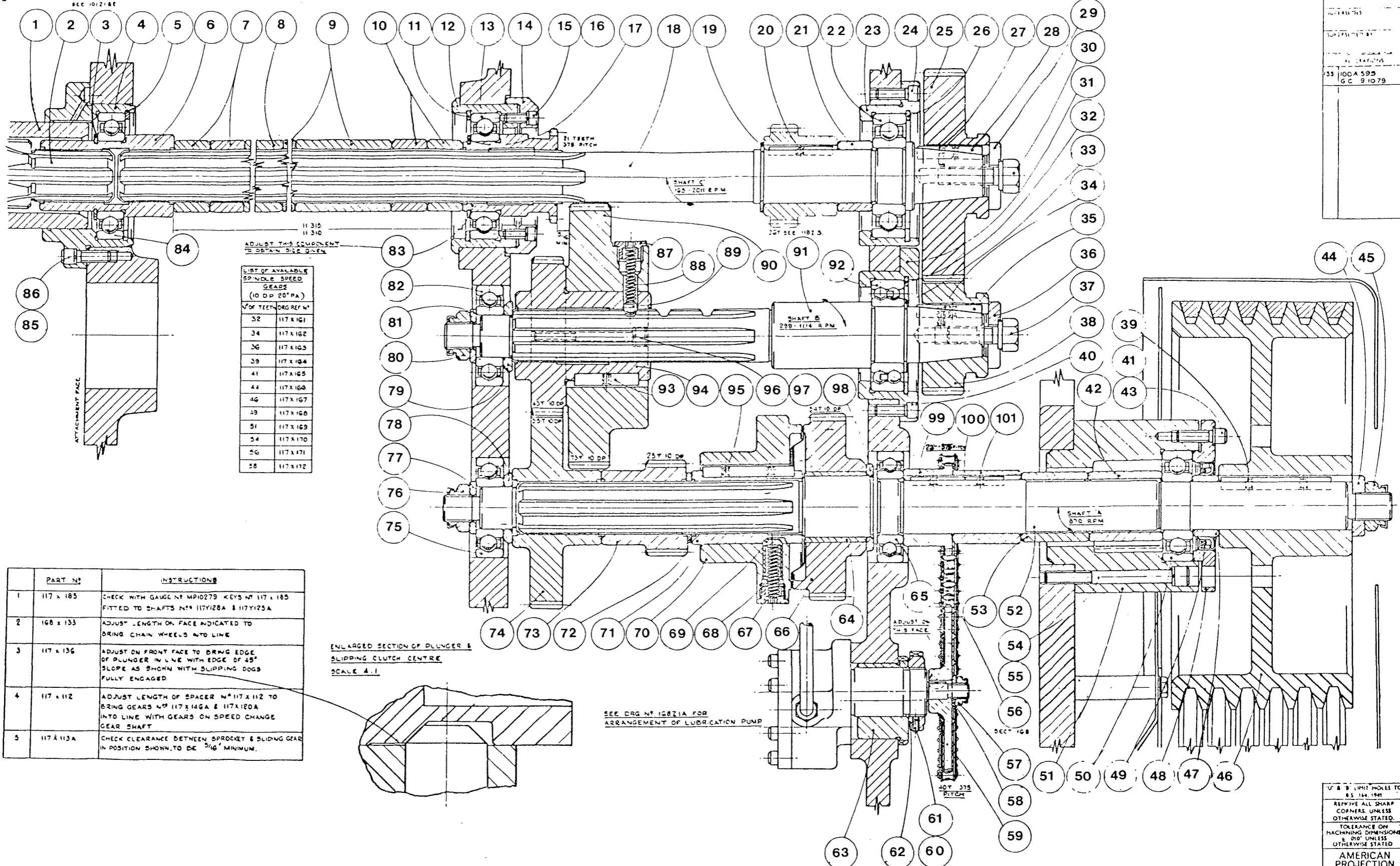

LIST OF AVAILABLE SPINDLE SPEED GEARS (10 DP 20° PA)

NO OF TEETH DRG REF NO	NO	NO
32	117 X 161	
34	117 X 162	
36	117 X 163	
39	117 X 164	
41	117 X 165	
44	117 X 166	
46	117 X 167	
49	117 X 168	
51	117 X 169	
54	117 X 170	
56	117 X 171	
58	117 X 172	

PART NO	INSTRUCTIONS
1	CHECK WITH GAUGE NO MP10279 KEYS NO 117 X 185 FITTED TO SHAFTS NO 117Y128A & 117Y125A
2	ADJUST LENGTH ON FACE INDICATED TO BRING CHAIN WHEELS INTO LINE
3	ADJUST ON FRONT FACE TO BRING EDGE OF PLUNGER IN LINE WITH EDGE OF 45° SLOPE AS SHOWN WITH SLIPPING DOGS FULLY ENGAGED
4	ADJUST LENGTH OF SPACER NO 117 X 112 TO BRING GEARS NO 117 X 146A & 117X180A INTO LINE WITH GEARS ON SPEED CHANGE GEAR SHAFT
5	CHECK CLEARANCE BETWEEN SPROCKET & SLIDING GEAR IN POSITION SHOWN TO BE 5/16" MINIMUM.

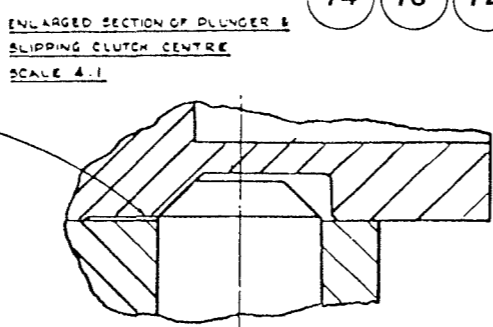

SEE DRG NO 10871A FOR ARRANGEMENT OF LUBRICATION PUMP

V & B UNIT HOLES TO B.S. 154:1987
 REMOVE ALL SHARP CORNERS UNLESS OTHERWISE STATED.
 TOLERANCE ON MACHINING DIMENSIONS & DIA UNLESS OTHERWISE STATED
 AMERICAN PROJECTION
 F - ROUGH MACHINE
 FF - FINISH MACHINE
 P - GRIND OR FURNACE
 PAW MATERIAL NO.

Drg No.11822 Electro-Magnetic Clutch & Brake for Feed Drive

1.	176/0405	Socket Set Screw, Cup Point, 1/4" B.S.F. x 5/16" long
2.	153/04	Soft Pad for 1/4" B.S.F. Screw
3.	150/28	Slotted Locknut, 1.3/4" dia. x 22 TPI
4.	118/119	Jockey Carrier
5.	118/162	Jockey Pin
6.	182/0410	Socket Set Screw, Taper Point, 1/4" B.S.F. x 5/8" long
7.	118/214	Spacer
8.	155/0756	Socket Head Cap Screw, 7/16" B.S.F. x 3.1/2" long
9.	130/07	Flat Washer, 7/16" dia.
10.	-	Jockey for Chain Drive between Shafts 'G' & 'K'
11.	118X169	Jockey Sprocket
12.	236/162018	Oil Retaining Bush
13.	118X213	Securing Link
14.	155/0614	Socket Head Cap Screw, 3/8" B.S.F. x 7/8" long
15.	130/06	Flat Washer, 3/8" dia.
16.	-	See Table, Item 110
17.	159/408	Socket Countersunk Head Screw, 4BA x 1/2" long
18.	118X200	Key for Pick-Off Gears
19.	118X117A	Bearing Housing. Upper Wormshaft
20.	262/30	Medium Angular 30mm
21.	118X161	Washer
22.	203/16L	Self-locking Nut 1" B.S.F.
23.	118X139	Collar
24.	104/33	Internal Circlip 62mm
25.	103/19	External Circlip 30mm
26.	118X101A	Bearing Housing
27.	118X145A	Input Shaft
28.	118Y138	Upper Wormshaft
29.	-	Shaft 'K'
30.	-	See Table. Item 111
31.	-	See Table. Item 111
32.	-	Feed Motion Input Gear on Shaft 'C'. See Drawing 117Z1A
33.	258/30	Ball Journal, Light, 30mm bore
34.	103/19	External Circlip, 30mm.
35.	159/408	Socket Countersunk Head Screw, 4BA x 1/2" long
36.	118X200	Key for Pick-off Gears
37.	118X148	'C' Washer
38.	118X197A	Feed Slip Gear Screw
39.	118X117A	Bearing Housing. Upper Wormshaft
40.	262/30	Medium Angular Contact 30mm
41.	118X167	Clutch Member
42.	130/12	Flat Washer, 3/4" dia.
43.	203/12L	Self-locking Nut, 3/4" B.S.F.
44.	118X161	Washer
45.	203/16L	Self-locking Nut
46.	18X161	Washer
47.	118X158A	Handwind Gear Spacer
48.	118X168	Wormshaft Sprocket
49.	262/35	Medium Angular Contact, 35mm
50.	122/1036T	Key, 5/16" x 7.32" x 2.1/4" long
51.	118X141	Spring Retaining Plus
52.	118X111	Clutch Spring
53.	118X199	Plunger
54.	236/182232	Oil Retaining Bush
55.	118Y127C	Slipping Clutch Body

56.	118X130A	Gear
57.	118X122A	Collar
58.	118X113B	Bearing Housing, Lower Wormshaft
59.	118X159	Collar
60.	118Y137A	Lower Wormshaft
61.	118X157	Adjusting Washer
62.	118X113B	Bearing Housing, Lower Wormshaft
63.	257/25	Ball Journal, Medium, 25mm bore
64.	130/12	Flat Washer, 3/4" dia.
65.	203/12L	Self-locking Nut, 3/4" B.S.F.
66.	258/40Z	Ball Journal, Light, 40mm bore
67.	154/04	Spring Washer, 1/4" dia.
68.	155/0410	Socket Head Cap Screw, 1/4" B.S.F. x 5/8" long
69.	118X133	Roller Retaining Plates
70.	118V131B	F.M. Clutch Cup
71.	104/38	Internal Circlip 80mm
72.	-	Shaft 'H' 5.08 to 606 RPM Feed Cycle 619.1 RPM Fast Motion
73.	8Y151B	F.M. Shaft
74.	118X142	Collar
75.	258/35Z	Ball Journal, Light 35mm bore
76.	183X126	No. 4 Herbert Clutch (Double)
77.	121/0820T	Key, 1/4" Square x 1.3/4" long
78.	118X207	Drive Pin
79.	118X192A	Feed Input Gear
80.	130/12	Flat Washer 3/4" dia.
81.	203/12L	Self-locking Nut, 3/4" B.S.F.
82.	257/25	Ball Journal. Medium, 25mm bore
83.	104/38	Internal Circlip 80mm
84.	118X241	Feed Mitre Gear
85.	-	Shaft 'H'
86.	118X196B	Wormshaft Mitre Wheel
87.	130/12	Flat Washer 3/4" dia.
88.	203/12L	Self-locking Nut, 3/4" B.S.F.
90.	118X239A	Bearing Housing
91.	-	Camshaft 'J' 0.2033 to 24.26 RPM Feed Cycle, 24.76 RPM Fast Motion
92.	-	See Drawing 144Z1 for Arrangement of Camshaft
93.	118Y232	Feed Clutch Shaft
94.	118X248A	Spring Abutment
95.	139/12	Dowel, 11/32" dia. x 1" long
96.	151/40	Slotted Locknut, 40mm
97.	153/04	Soft Pad for 1/4" B.S.F. Screw
98.	176/0405	Socket Set Screw, cup Point, 1/4" B.S.F. x 5/16" long
99.	265/40	Ball Journal, Light, Double Row, 40mm
100.	118X132	Free Wheel Body
101.	155/0410	Socket Head Cap Screw, 1/4" B.S.F. x 5/8" long
102.	189/6	Shakeproof Washer, 1/4" dia.
103.	118Y204A	Lower Wormwheel Oilbath
104.	-	Roller, 7.16" dia.
105.	118X134	Free Wheel Plunger
106.	118X144A	Spring for Free Wheel
107.	-	Section 'XX' through Free Wheel on Shaft 'F'
108.	-	Drawing No.
109.	-	No. of Teeth
110.	-	List of available Feed Gears 10 DP.20 PA

MACHINE	GEAR				
	C	D	F	G	H
Standard Index Time	117X139B 28T	118X165B 68T	118X193B 46T	118V268 59T	118X135
Fast Index Time Special Order	117X139B 22T	118X165B 68T	118X193B 46T	118V268 59T	118X135
8" Long Bar Feed Special	160X133A 29T	118X188 61T	160X132A 33T	72T	160X162

112. 153/04	Soft Pad for 1/4" B.S.F. Screw
113. 176/0405	Socket Set Screw, Cup Point, 1/4" B.S.F. x 5/16" long
114. 151/35	Slotted Locknut, 35mm
115. 154/05	Spring Washer, 5/16" dia.
116. 155/0516	Socket Head cap Screw, 5/16" B.S.F. x 1" long
117. 118V.235	Bearing Mounting Sleeve
118. 118X267	Spacer
119. 104/48	Internal Circlip 130mm
120. 268/85	Ball Journal, Extra Light, 85mm
121. 103/38	External Circlip 80mm.
122. 268/40	Journal, Extra Light, 40mm
123. 118V236	Clutch Sleeve
124. 118V230	Electro-Magnetic Clutch
125. 154/03	Spring Washer, 2BA
126. 155/0214	Socket Head Cap Screw, 2BA x 7/8" long
127. 118X251	Spring
128. 257/25	Ball Journal, Medium, 25mm
129. 154/05	Spring, Washer, 5/16" dia.
130. 155/0556	Socket Head Cap Screw, 5/16" B.S.F. x 3.1/2" long
131. 268/40	Ball Journal, Extra Light, 40mm
132. 1300-68M	Anderton Circlip
133. -	See Table, Item 111
134. 118X252	Outer Spacer
135. 116X265	Adjustment Spacer
136. 126/0810	Dowel, Hardened, 1/4" dia. x 5/8" long
137. 118X264	Spacer
138. 118X260	Metric Key
139. 118X245	Bobbin
140. -	Fast Motion Shaft
142. 118X244	Adjusting Washer
143. 118V238	Sliding Clutch
145. 154/05	Spring Washer 5/16" dia.
146. 155/0564	Socket Head Cap Screw, 5/16" B.S.F. x 4" long
147. 118X258	Metric Key
148. 203/14L	Self-locking Nut, 7/8" B.S.F.
149. 118V231A	Electro-Magnetic Spring Brake
150. 130/14	Flat Washer 7/8" dia.
151. 118X266	Adjustment Collar
152. 104/33	Internal Circlip 62mm
153. 118V233	Brake Mounting Body
154. -	Shaft 'G' 5.08 to 606 RPM Feed Cycle 619 RPM Fast Motion

155.	130/12	Flat Washer 3/4" dia.
156.	203/12L	Self-locking Nut, 3/4" B.S.F.
157.	168X160	Oil Bush
158.	118X208	Oil Nipple
159.	273/35Z	Roller Journal, Light, 35mm
160.	118X250	Inner Spacer
161.	121/0828T	Tapped Key, 1/4" Square x 1.3/4" long
162.	-	Shaft 'F' 946.6 to 7.93 RPM Feed Cycle 966 RPM Fast Motion
163.	118X202	Fast Motion Clutch Key
164.	121/1040T	Tapper Key, 5/16" Square x 2.1/2" long
165.	118X135	Clutch Gear
166.	118X109	Collar
167.	118X110	Spacer
168.	118X108	Spacer
169.	104/36	Internal Circlip, 72mm
170.	-	See Table, Item 111
171.	118X107A	Bearing Housing
172.	155/0512	Socket Head Cap Screw, 5/16" B.S.F. x 3/4" long
173.	118V261	Bearing End Cap
174.	219/17	Enots Male Elbow Adaptor Y55, 1/8" BSP
175.	257/25	Ball Journal, Medium, 25mm
176.	104/33	Internal Circlip, 62mm
177.	155/0512	Socket Set Screw, 5/16" B.S.F. x 3/4" long
178.	118X148	'C' Washer
179.	-	See Table, Item 110
180.	118X197A	Feed Slip Gear Screw
181.	118X200	Key for Pick-Off Gears
182.	159/408	Socket Countersunk Head Screw, 4BA x 1/2" long
183.	-	Fast Motion Input Gear on Shaft 'A', See drawing 117Z1A.
184.	-	Shaft 'E' 18.25 to 2177 RPM
185.	118Y149A	Intermediate Shaft
186.	118X128A	Slipping Clutch Centre
187.	103/19	External Circlip, 30mm
188.	258/30	Ball Journal, Light, 30mm
189.	118X197A	Feed Slip Gear Screw
190.	155/0512	Socket Head Cap Screw, 5/16" B.S.F. x 3/4" long
191.	154/05	Spring Washer, 5/16" dia.
192.	155/0544	Socket Head Cap Screw 5/16" B.S.F. x 2.3/4" long
193.	118X148	'C' Washer
194.	118X197A	Feed Slip Gear Screw
195.	-	Shaft 'D' 66.91 to 820.9 RPM

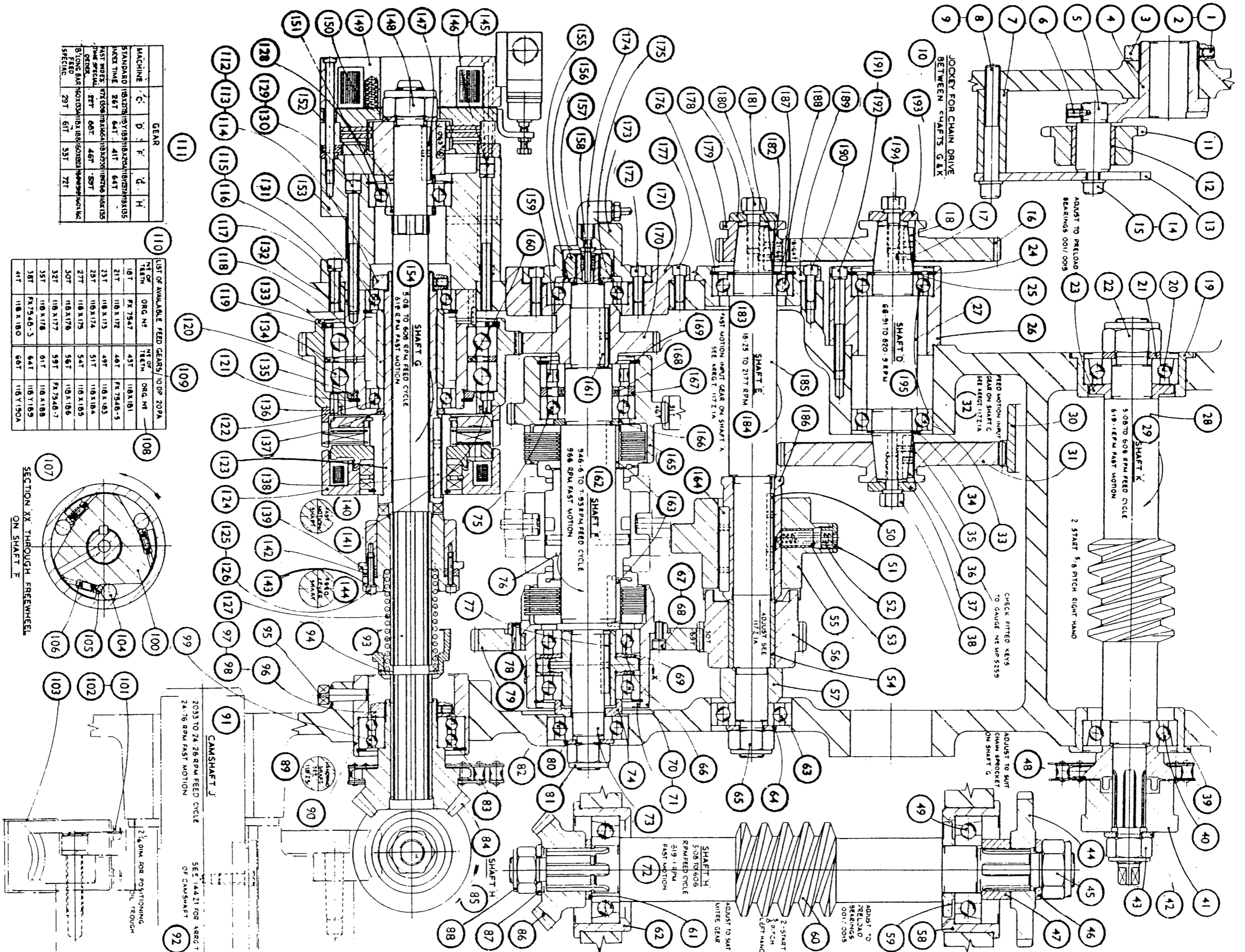

MACHINE	C	D	E	G	H
STANDARD	102	103	104	105	106
NO. TIME	2.5	4.1	4.1	6.4	6.4
FAST MOTION	172	173	174	175	176
TIME PER MIN	4.6	4.6	4.6	4.6	4.6
FEED	102	103	104	105	106
STANDARD	102	103	104	105	106
SPECIAL	291	311	331	721	

LIST OF AVAILABLE FEED GEARS, 100% 20 P.A.	TECH. NO.	TECH. NO.	TECH. NO.	TECH. NO.
18T	FX 7547	49T	110 X 181	108
21T	110 X 172	46T	FX 7548-5	109
23T	110 X 173	49T	110 X 183	110
25T	110 X 174	51T	110 X 184	111
27T	110 X 175	54T	110 X 185	112
30T	110 X 176	56T	110 X 186	113
32T	110 X 177	59T	FX 7548-7	114
35T	110 X 178	61T	110 X 188	115
38T	FX 7548-3	64T	110 Y 189	116
41T	110 X 180	66T	110 Y 190A	117

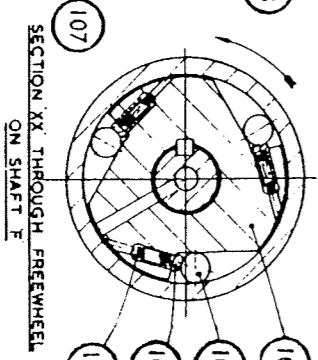

118 Z 2 ARRANGEMENT OF ELECTRO-MAGNETIC CLUTCH & BRAKE FOR FEED DRIVE

Drg No.118Z5

Motor Drive End of Main Drive Housing
(Electro-Magnetic Brake & Clutch)

1. See Plate 6 Spindle Speed Change Gears, 32 Teeth to 58 Teeth
2. See Plate 7 Feed Pick-Off Gears, 18 Teeth to 66 Teeth
3. - Upper Wormshaft
4. 110046 Renold Chain, 1/2" Pitch, 0.335" Roller dia.,
81 pitches long.
5. - Feed Pick-Off Gears, 21 Teeth to 62 Teeth
6. 122Y243 Change Gear Cover
7. 291/81 Legend Plate
8. 291/2 Legend Plate
9. 165/404 Round Head Set Screw, 4BA x 1/4" long
10. - Screw into these keep holes 2.5mm x 45mm screws
supplied with Ortlinghaus brake unit
11. 118X141 Spring Retaining Plug
12. 165/404 Round Head Set Screw 4BA x 1/4" long
13. 318X253 Brake Release Instruction Plate
14. 118V255 Brake Adjustment Name Plate
15. 165/404 Round Head Set Screw 4BA x 1/4" long
16. 155/0410 Socket Head Cap Screw, 1/4" B.S.F. x 5/8" long
17. 155/04 Spring Washer, 1/4" dia.
18. Place in slot on inside of cover reset pin (0-27-546-11-000)
(1-027-546-11-000) Supplied with Ortlinghaus
Brake Unit
19. 322V241 Brake Housing Cover
20. 322X242 Reset Pin Retaining Plate
21. 165/404 Round Head Set Screw 4BA x 1/4" long
22. 155/0514 Socket Head Cap Screw, 1/4" B.S.F. x 5/8" long
23. 154/05 Spring Washer, 5/16" dia.
24. 122Z240A Magnetic Brake Housing
25. 322X244 Coolant Drive End Cover
26. 155/0410 Socket Head Cap Screw, 1/4" B.S.F. x 5/8" long
27. 154/04 Spring Washer, 1/4" dia.
28. 110038 Renold Chain, 5/8" Pitch, 0.250" dia. 58 Pitches long
29. 117X101B Coolant Drive End Cover
30. 122V245 Modified Belt Guard
31. 122X246 Modified Backplate Extension

FIRST USED ON BATCH
LAST USED ON BATCH
SUPERSEDES
SUPERSEDED BY
ALTERATIONS
ISSUE NO. 100A 595
GC 25 10.79

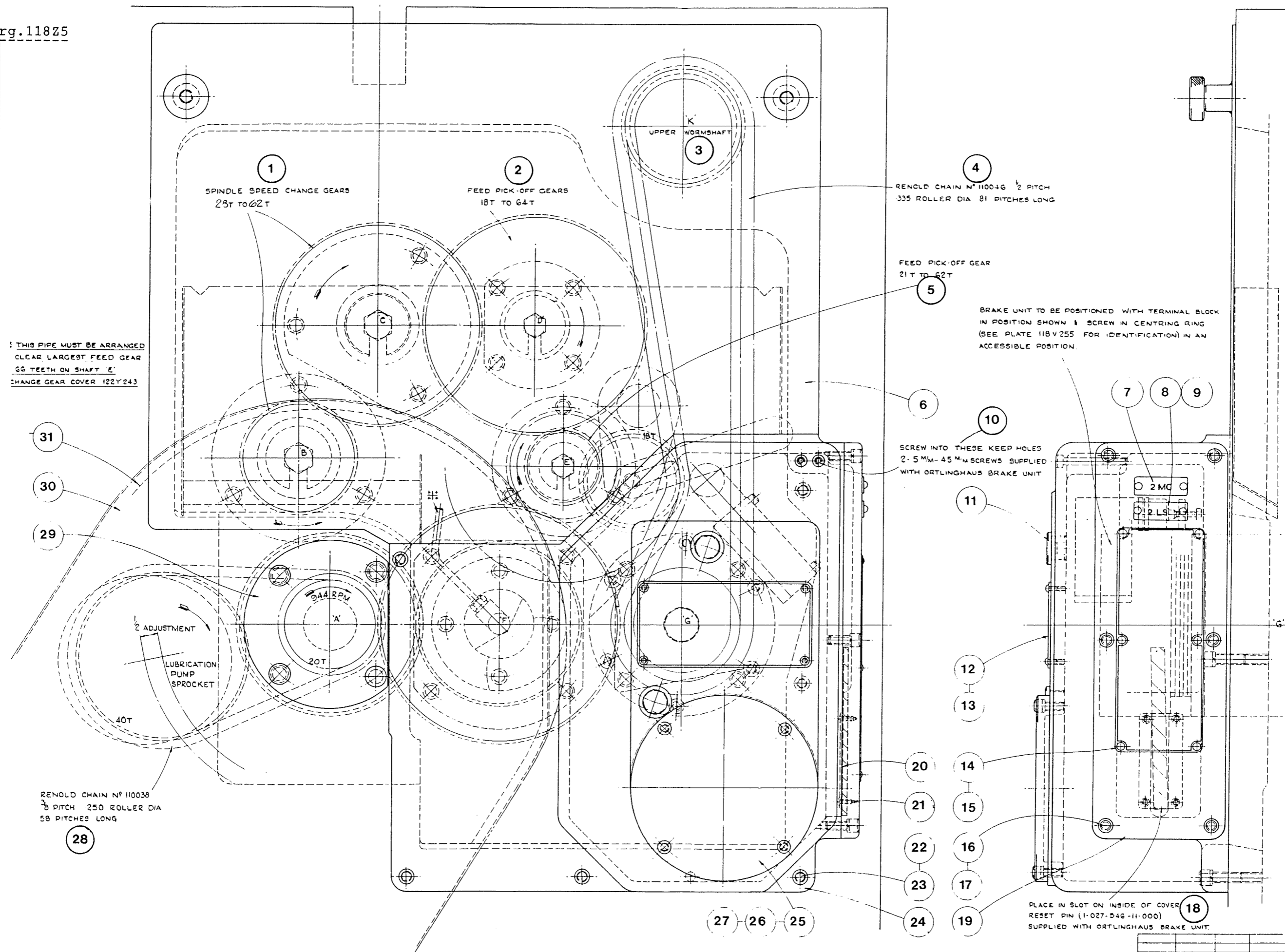

THIS PIPE MUST BE ARRANGED CLEAR LARGEST FEED GEAR 66 TEETH ON SHAFT 'E' CHANGE GEAR COVER 122Y243

RENOLD CHAIN N° 110046 1/2 PITCH 335 ROLLER DIA 81 PITCHES LONG

FEED PICK-OFF GEAR 21T TO 62T

BRAKE UNIT TO BE POSITIONED WITH TERMINAL BLOCK IN POSITION SHOWN 1 SCREW IN CENTRING RING (SEE PLATE 118V255 FOR IDENTIFICATION) IN AN ACCESSIBLE POSITION.

SCREW INTO THESE KEEP HOLES 2.5MM-45MM SCREWS SUPPLIED WITH ORTLINGHAUS BRAKE UNIT

RENOLD CHAIN N° 110038 3/8 PITCH 250 ROLLER DIA 58 PITCHES LONG

PLACE IN SLOT ON INSIDE OF COVER RESET PIN (1-027-546-11-000) SUPPLIED WITH ORTLINGHAUS BRAKE UNIT

WICKMAN MACHINE TOOL MANUFACTURING CO L^{TD} COVENTRY ENGLAND.

THIS DRAWING AND DESIGN IS THE PROPERTY OF WICKMAN MACHINE TOOL MANUFACTURING CO L^{TD} AND IS NOT TO BE REPRODUCED OR TRANSMITTED IN ANY FORM OR BY ANY MEANS WITHOUT PERMISSION AND IS SUBJECT TO CHANGE WITHOUT NOTICE.

MOTOR DRIVE END OF MAIN DRIVE HOUSING (ELECTRO MAGNETIC BRAKE & CLUTCH)

SCALE FULL SIZE DRAWN G.C. 3.10.79 CHECKED T.R.C. MAFTRIAL

No. OFF	ARRANGEMENT	SECTION	MACHINE
	DRG No	118A	1-GF

MARK DRG. No AT 118.2.5.

Drg No.119Z5 ----- Control Shaft Arrangement

1.	182/0416	Socket Set Screw, Taper Point 1/4" B.S.F. x 1" long
2.	119V209	Rear Lever Boss
3.	125/2236	Taper Pin 11/32" dia. x 2.1/4" long
4.	119X232	Bearing Bush
5.	182/0616	Socket Set Screw, Taper Point 3/8" B.S.F. x 1" long
6.	319V203	Lever
7.	121/1020T	Key, Tapped, 5/16" square x 1.1/4" long
8.	319X214	Link Pin
9.	130/06	Flat Washer 3/8" dia.
10.	327/0608	Cotter Pin, 3/32" dia. x 1" long
11.	219X192	Glut Pin
12.	219X110	Glut
13.	122/1032T	Key, Tapped 7/32" x 5/16" x 2" long
14.	119Y201	Glut Lever
15.	101/19	External Circlip 1.5/8" dia.
16.	119Y205	Glut Sleeve
17.	-	Shaft 'Q1'
18.	119V206	Feed Lever Shaft
19.	101/19	External Circlip 1.5/8" dia.
20.	122/1032T	Key, Tapped 7/32" x 5/16" x 2" long
21.	167/0410	Hexagon Head Screw, 1/4" B.S.F. x 5/8" long
22.	198/8	Lockwasher
23.	119X222	Switch Bracket
24.	319X226	Spacer
25.	119V207	Bearing Sleeve
26.	155/0514	Socket Head Cap Screw, 5/16" B.S.F. x 7/8" long
27.	154/05	Spring Washer 5/16" dia.
28.	182/0612	Socket Set Screw, Taper Point, 3/8" B.S.F. x 3/4" long
29.	125/2236	Taper Pin, 11/32" dia. x 2.1/4" long
30.	119V220	Front Lever Boss
31.	119Y202	Interlock Lever
32.	150X123A	Spring Anchor
33.	173/10	Locknut 5/16" B.S.F.
34.	155/0506	Socket Head Cap Screw 5/16" B.S.F. x 3/8" long
35.	236/162016	Oil Retaining Bush 1" bore x 1.1/4" x 1" long
36.	119X231	Handwind Shaft Collar
37.	119X198A	Driving Sleeve
38.	219X227	Feed Lever
39.	125/2232	Taper Pin 11/32" dia. x 2" long
40.	125/2228	Taper Pin 11/32" dia. x 1.3/4" long
41.	241/9	Bakelite Knob
42.	B51A	Switch, Square 'D' Type B, class 9007
43.	MA1	Lever Arm, Square 'D' Class 9007
44.	156/220	Socket Head Cap Screw, 2BA x 11/4" long
45.	156/212	Socket Head Cap Screw, 2BA x 3/4" long
46.	154/03	Spring Washer 3/16" dia.
47.	119X223	Switch Bracket
48.	198/12	Lockwasher
49.	167/0516	Hexagon Head Screw, 5/16" B.S.F. x 1" long
50.	236/162016	Oil Retaining Bush, 1" bore x 1.1/4" x 1" long
51.	125/2232	Taper Pin, 11/32" dia. x 2.1/4" long
52.	119X211	Handwind Sliding Gear
53.	-	Handwind Position
54.	-	Driving Dogs Engaged
55.	155/0412	Socket Head Cap Screw 1/4" B.S.F. x 3/4" long
56.	319X217	Link Screw, Left-Hand
57.	419X135	Special Locknut

58.	319X218	Link Screw, Right-Hand
59.	173/06L	Locknut, 3/8" B.S.F.
60.	319X219	Adjusting Nut
61.	119X216	Link
62.	155/0624	Socket Head Cap Screw, 3/8" B.S.F. x 1.1/2" long
63.	154/06	Spring Washer, 3/8" dia.
64.	519X204	Revolving Handle
65.	-	Fast Motion
66.	-	Feed
67.	-	Shaft 'R'
68.	327/0608	Cotter Pin 3/32" dia. x 1" long
69.	130/06	Flat Washer, 3/8" dia.
70.	319X215	Link Pin
71.	101/18	External Circlip 1.1/2" dia.
72.	319X213	Spacer
73.	319V204	Lever
74.	119V208	Bearing Sleeve
75.	155/0514	Socket Head Cap Screw 5/16" B.S.F. x 7/8" long
76.	154/05	Spring Washer 5/16" dia.
77.	219X231	Handwind Shaft Collar
78.	125/2232	Taper Pin, 11/32" dia. x 2" long
79.	119X198A	Driving Sleeve
80.	125/2228	Taper Pin 11/32" dia. x 1.3/4" long
81.	119X230	Handwind Shaft
82.	219X227	Feed Lever
83.	241/9	Bakelite Knob
84.	119Y109B	Handwind Lever
85.	-	Steel Ball, 5/16"
86.	219X193	Locating Spring
87.	219X194	Spring Retainer
88.	327/0608	Cotter Pin, 3/32" dia. x 1" long
89.	130/06	Flat Washer, 3/8" dia.
90.	319X214	Link Pin

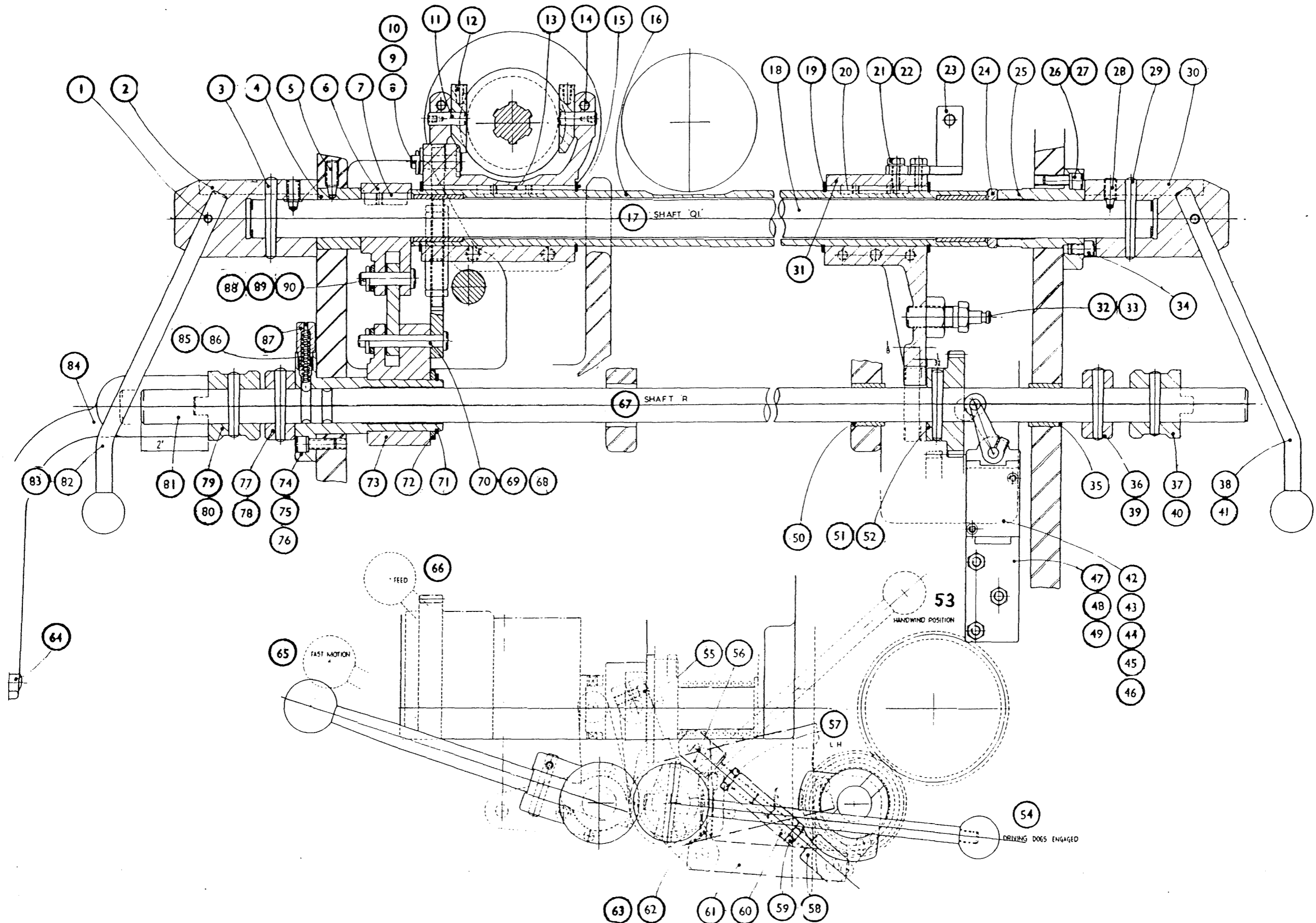

Drg No.119Z6A Control Shaft Arrangement

1.	155/0510	Socket Head Cap Screw, 5/16" B.S.F. x 5/8" long
2.	119X130	Fast Motion Cam
3.	119X176A	Outer 'T' Nut
4.	155/0410	Socket Head Cap Screw, 1/4" B.S.F. x 5/8" long
5.	203/04L	Locknut 1/4" B.S.F.
6.	BZLN-2-LHBE6	Honeywell Micro-Switch
7.	120X124C	Switch bracket
8.	125/1016	Taper Pin 5/32" dia. x 1" long
9.	119X133	Roller Pin
10.	119X194	Roller
11.	119Y119A	Lever
12.	130/08	Flat Washer, 1/2" dia.
13.	203/08L	Locknut, 1/2" B.S.F.
14.	155/0408	Socket Head Cap Screw, 1/4" B.S.F. x 1/2" long
15.	130/04	Flat Washer, 1/4" dia.
16.	119X144	Link Pin
17.	327/0405	Cotter Pin, 1/16" dia. x 5/8" long
18.	119X131	Feed Motion Cam
19.	154/04	Spring Washer, 1/4" dia.
20.	155/0412	Socket Head Cap Screw, 1/4" B.S.F. x 3/4" long
21.	119X221	Lever Pivot Pin
22.	119X139A	Link Connector
23.	119X197	Special Locknut
24.	155/0520	Socket Head Cap Screw 5/16" B.S.F. x 1.1/4" long
25.	203/05	Locknut 5/16" B.S.F.
26.	118V249	Support Bracket
27.	120X125A	Switch Plate
28.	118X254	Restraining Arm
29.	121/0824T	1/4" Sq. Tapped Key 1.1/2" long
30.	119V135	Lever Boss
31.	182/0510	5/16" B.S.F. Socket Head Set Screw 5/8" long Taper Point
32.	119X142A	Link
33.	173/08L	Locknut 1/2" B.S.F.
34.	119X143	Link Connector
35.	327/0405	Cotter Pin 1/16" dia. x 5/8" long
36.	119X144	Link Pin
37.	119X210	Special Taper Pin
38.	203/04L	Locknut 1/4" B.S.F.
39.	119X125	Lever
40.	119X126B	Glut Lever
41.	121/0832T	Key, Tapped, 1/4" Square x 2" long
42.	119X161A	Fast Motion Lever Shaft
43.	155/0408	Socket Head Cap Screw, 1/4" B.S.F. x 1/2" long
44.	154/04	Spring Washer 1/4" dia.
45.	130/04	Flat Washer, 1/4" dia.
46.	155/0408	Socket Head Cap Screw, 1/4" B.S.F. x 1/2" long
47.	203/04	Locknut, 1/4" B.S.F.
48.	130/04	Flat Washer, 1/4" dia.
49.	155/0408	Socket Head Cap Screw, 1/4" B.S.F. x 1/2" long
50.	154/04	Spring Washer, 1/4" dia/
51.	BZLN-2-LHBE6	Honeywell Micro-Switch
52.	119X110	Glut (Fast Motion)
53.	125/1014	Taper Pin, 5/32" dia. x 7/8" long
54.	119X193	Glut Pin
55.	119X136	Spacer
56.	121/0824T	1/4" sq. Tapped Key 1.1/2" long
57.	119V135	Lever Boss

58.	182/0510	5/16" B.S.F. Socket Head Set Screw 5/8" long Taper Point
59.	2441/D87/X1	Conduit Seal
60.	BA1	Operating Arm, Square 'D'
61.	AW12	Limit Switch, Square 'D' Class 9007
62.	156/224	Socket Head Cap Screw, 2BA x 1.1/2" long
63.	154/03	Spring Washer, 3/16" dia.
64.	219X174	Switch bracket
65.	186X119	Spring Anchor
66.	MSE.326	Morris Spring
67.	198/8	Lockwasher, 1/4" dia.
68.	167/0410	Hexagon Head Screw, 1/4" B.S.F. x 5/8" long
69.	203/05	Locknut 5/16" B.S.F.
70.	167/0524	Hexagon Head Screw, 5/16" B.S.F. x 1.1/2" long
71.	155/0524	Socket Head Cap Screw, 5/16" B.S.F. x 1.1/2" long

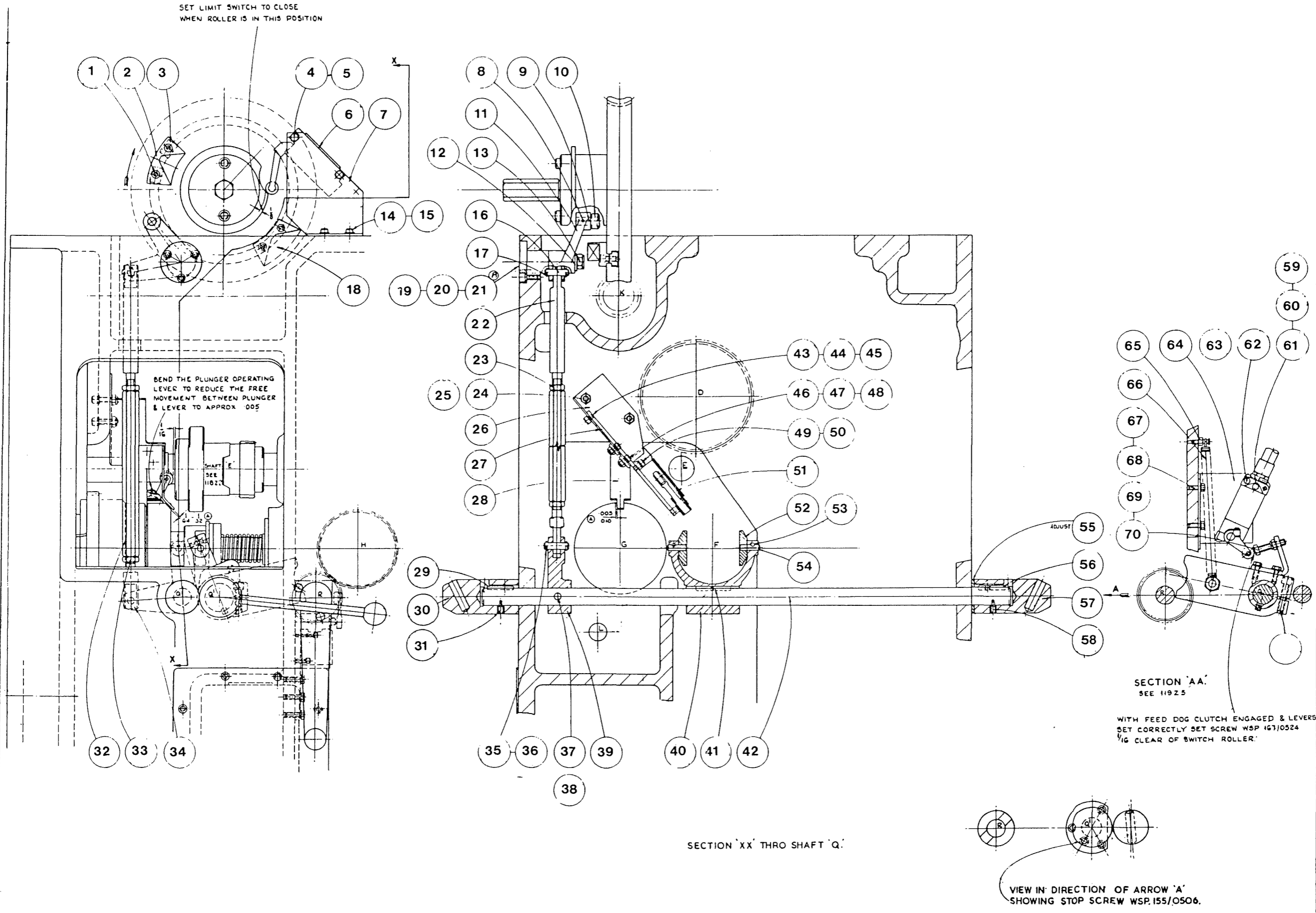

U & B LIMIT HOLES TO BS 164:1961
REMOVE ALL SHARP CORNERS UNLESS OTHERWISE STATED.
TOLERANCE ON MACHINING DIMENSIONS: ± .010 UNLESS OTHERWISE STATED.
AMERICAN PROJECTION

VIEW IN DIRECTION OF ARROW 'A'
SHOWING STOP SCREW WSP.155/0506.

Drg No. 122Z3C Cover Arrangement

1.	179/203	2BA x 3/16" Long Socket Cap Screw Cup Point
2.	173/04	1/4" B.S.F. Hex. Nut
3.	130/04	Plain Washer
4.		
5.	167/0508	5/16" B.S.F. x 1/2" Long Hexagon Head Screws
6.	122X176B	Attachment Bore Cover Plate
7.	167/0508	5/16" B.S.F. x 1/2" Long Hexagon Head Screws
8.	122X177B	Glut Shaft Bore Cover Plate
9.	122X178B	Pusher Shaft Cover Plate
10.	167/0508	5/16" B.S.F. x 1/2" Long Hexagon Head Screws
11.	122X180A	Chasing Drive Bore Cover
12.	167/0508	5/16" B.S.F. X 1/2" Long Hexagon Head Screws
13.	167/0508	5/16" B.S.F. X 1/2" Long Grub Screw
14.	167/0508	5/16" B.S.F. x 1/2" Long Grub Screw
15.	176/0404	1/4" B.S.F. x 1/4" Long Grub Screw
16.	236/62016	1" Bore x 1.1/4" O.D. X 12
17.	176/0708	7/16" B.S.F. X 1/2" Long Grub Screw
18.	522X208	Plug 2.1/4" Dia.
19.	122X154	Extractable Plug
20.	156/204	2BA x 1/4" Long Socket Cap Head Screw
21.	122X198A	Coolant Guard Plate
22.	159/212	2BA x 3/4" long Countersunk Head
23.	122V150A	Cover for Rear Internal slide Bore
24.	213/2	2BA Nipple
25.	122V211	Sealing Ring Retainer

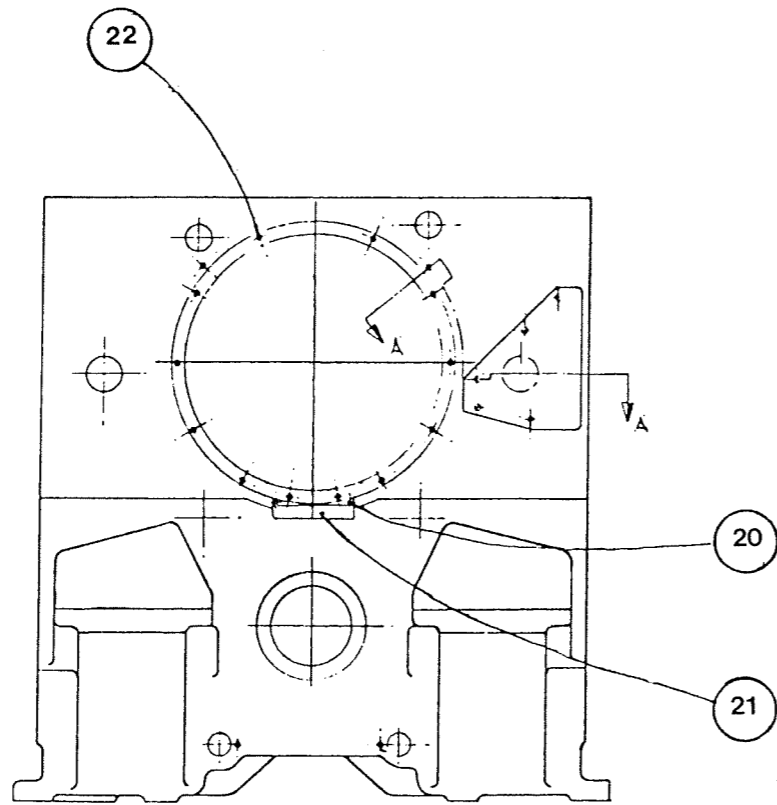
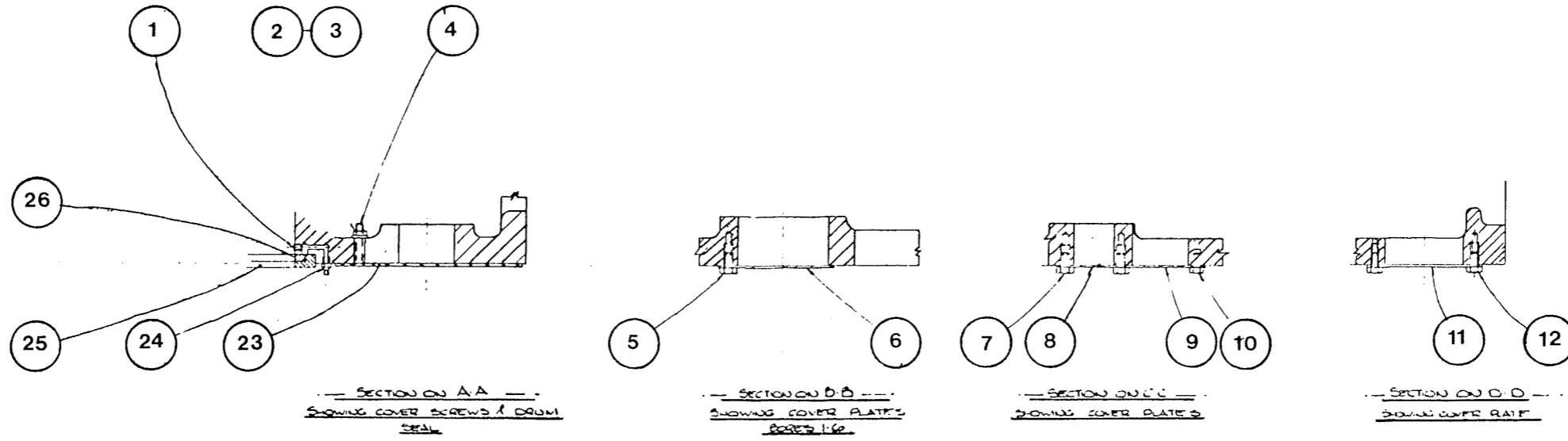

—VIEW ON DRUM HOUSING FACE—

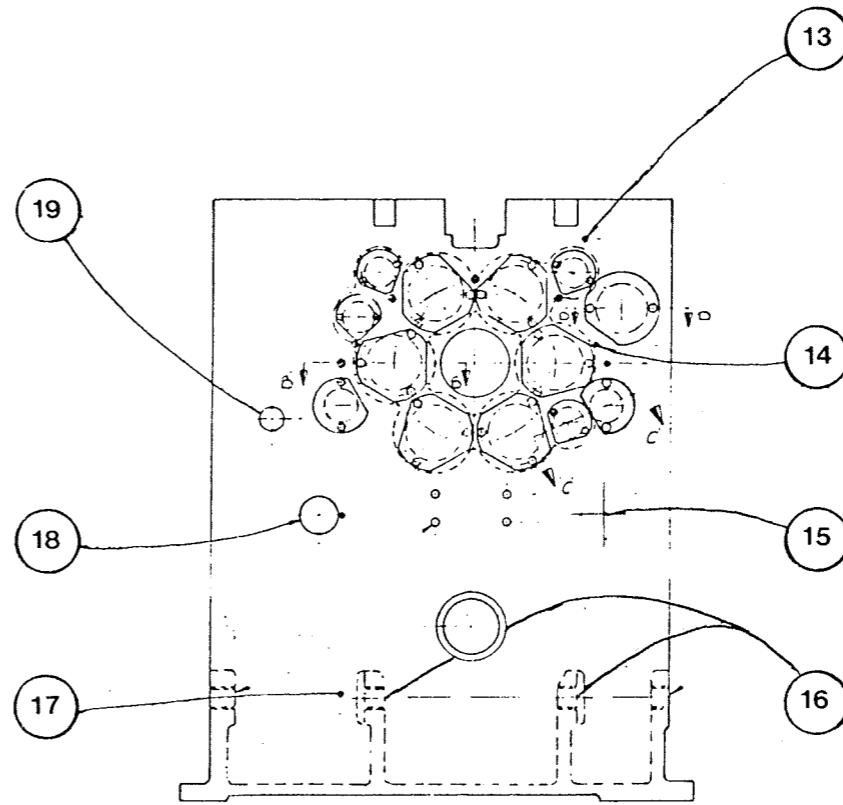

—VIEW ON DRIVE HOUSING FACE—

FIRST USED ON
LAST USED ON
SUPERSEDES
SUPERSEDED BY
ALTERATIONS

1/4" & 1/2" LIMIT HOLES TO B.S. 184:1941

REMOVE ALL SHARP CORNERS UNLESS OTHERWISE STATED

TOLERANCE ON MACHINING DIMENSIONS ± .010" UNLESS OTHERWISE STATED.

AMERICAN PROJECTION

R = ROUGH MACHINE
FF = FINISH MACHINE
FFF = GRIND OR EQUIVALENT

RAW MATERIAL No.

SCALE	DRAWN	CHECKED	TRACED	TRACING CHECKED	MATERIAL	No. OFF	ARRANGEMENT	DRG. No.	SECTION	MACHINE	DRG. NO.
1/8" FULL SIZE	RA	AS	DW	2-12-73	UA	-	-	122	1-C		122Z3C

Drg No.122Y16 ----- Bar Feed Cover Interlock

1.	155/0420	1/4 B.S.F. Socket Head Cap Screw 1.1/4" long
2.	3SE3120-1G	Siemens Limit Switch
3.	326/0816	1/4 Dia. Tension Pin x 1" long
4.	304X159	Spacer
5.	203/04	1/4 B.S.F. Self Locking Nut
6.	122X250	Switch Cam
7.	122Z169	Bar Feed Cover
8.	167/0412	Hex. Head Set Screw 1/4 B.S.F. 3/4" long
9.	122X254	Switch Base
10.	156/224	2BA Socket Head Cap Screw 1.1/2" long
11.	08.060514	5mm Dia. Tension Pin
12.	15011316	Conduit Thread Adaptor 13.5 fg - 16mm
13.	110309	Seal Bonded Rubber 16mm Conduit
14.	15041600	Conduit Connector 16mm - 5/8 Conduit
15.	347/1060	'Anaconda' Flexible Conduit 5/8" x 5 ft.
16.	122V252	Mod. to End Bracket
17.	291/14	Legend Plate
18.	165/404	Round Head Set Screw 4BA 1/4 long.
19.	167/0412	Hex. Head Set Screw 1/4 B.S.F. 3/4" long
20.	226/0812	Tension Pin
21.	122X251	Mounting Block

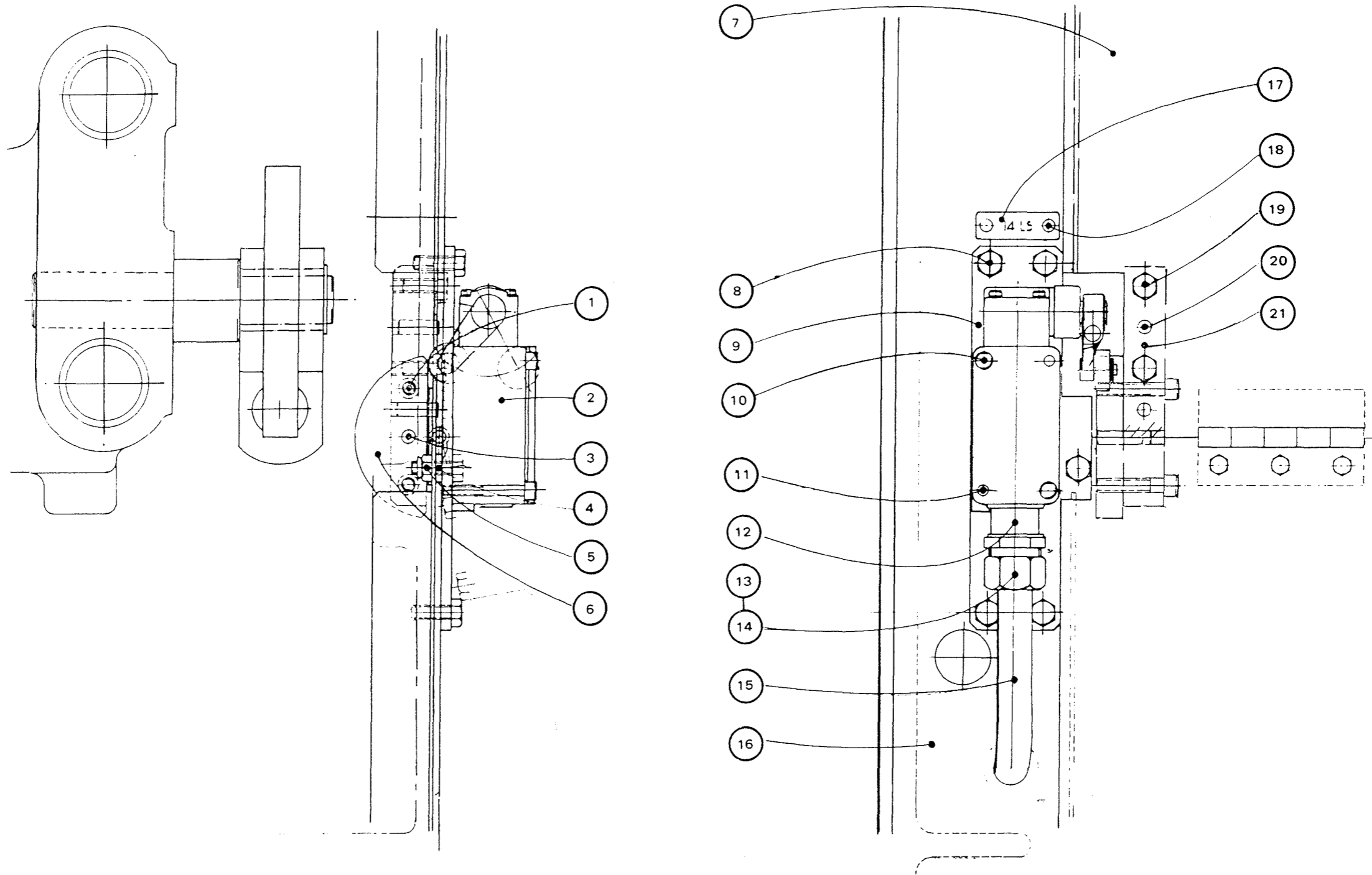

Drg No. 122Z4B Arrangement of Upper Motions Covers

1. 171Z577B Trunking 171 Sect.
2. 155/0408 1/4" B.S.F. x 1/2" Long Socket Head Cap Screws
3. 122X130A Door Knob
4. 122X196B Cover for Timing Dogs
5. 122V147E End Cover Long Motions
6. 372X123 Cover
7. 165/406 4BA x 3/8" Long Screw Round Head Set Screw
8. 203/A 4BA Pinnacle Nut
9. 122X190 Securing Block
10. 155/0828 1/2" B.S.F. x 1.3/4" Long Socket Head Cap Screws
11. 154/08 1/2" Spring Washer
12. 122Z195E Rear Side Cover
13. 122V193 Top Sliding Cover
14. 122130A Door Knob
15. 122194C Front Side Cover
16. 122Y160 Name Plate
17. 155/0410 1/4" B.S.F. x 5/8" long Socket Head Cap Screws
18. 203/04L 1/4 B.S.F. Pinnacle, Thin Nut
19. 222X227 Screw
20. 155/0616 3/8" B.S.F. x 1" long Socket Head Cap Screws
21. 122X263 Spacer
22. 155/0632 3/8" B.S.F. x 2" Long Socket Head Cap Screws
23. 122Z262 Support Frame
24. 156/204 2BA x 1/4" Long Socket Head Cap Screws
25. 164V201 Tool Tray

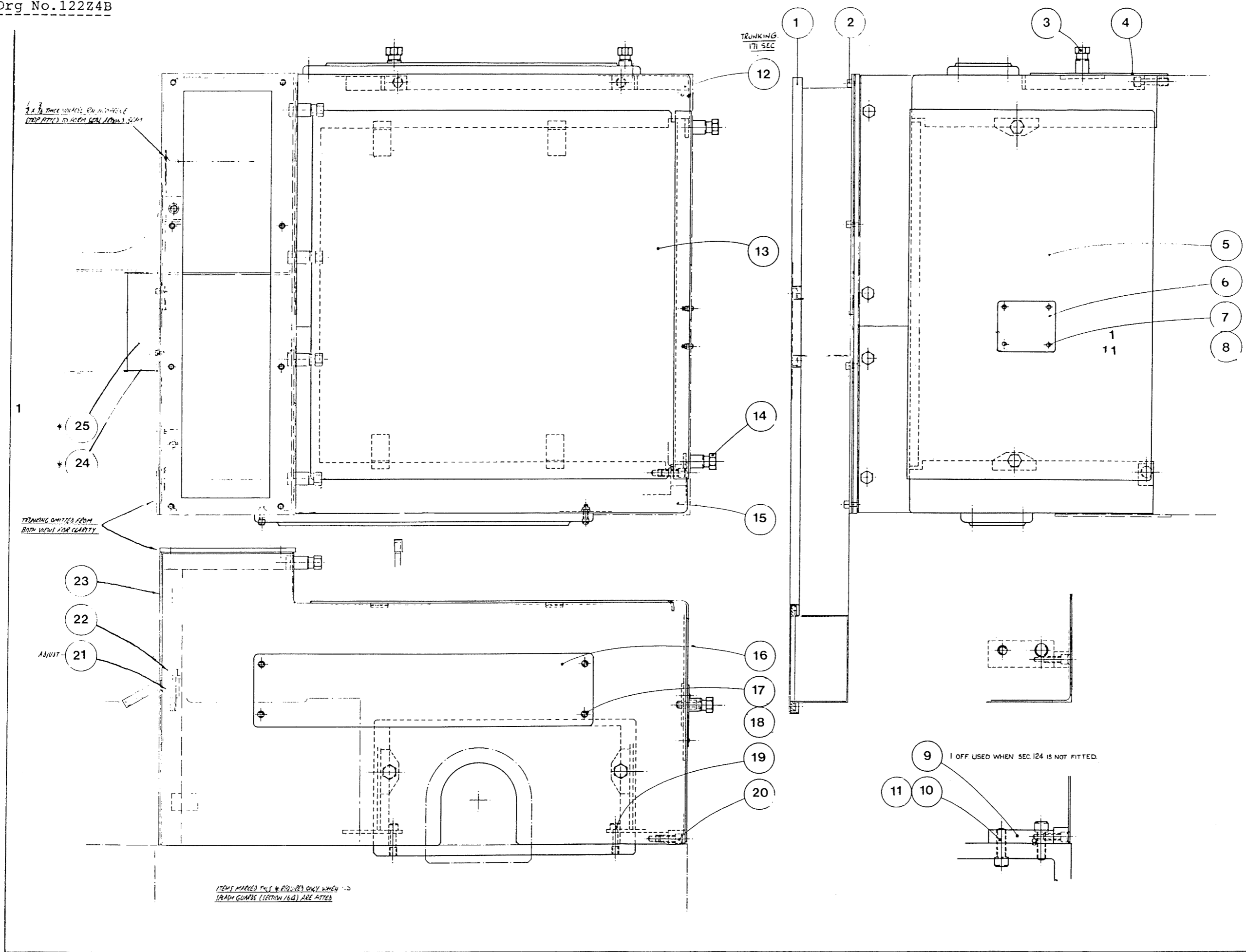

FIRST USED ON
LAST USED ON
SUPersedES 122 Z 4 A
SUPersedED BY
ALTERATIONS 122 Z 4 B 26. 8. 80

Drg No.123Z1A ----- Longitudinal Motions - Plan

- 1. 141/13 1/2" dia. Taper Pin 1.3/4" long
- 2. 102/9 7/8" dia. Internal Circlip
- 3. 141X159 Stop Shaft
- 4. 123X177 Stop Shaft Bush

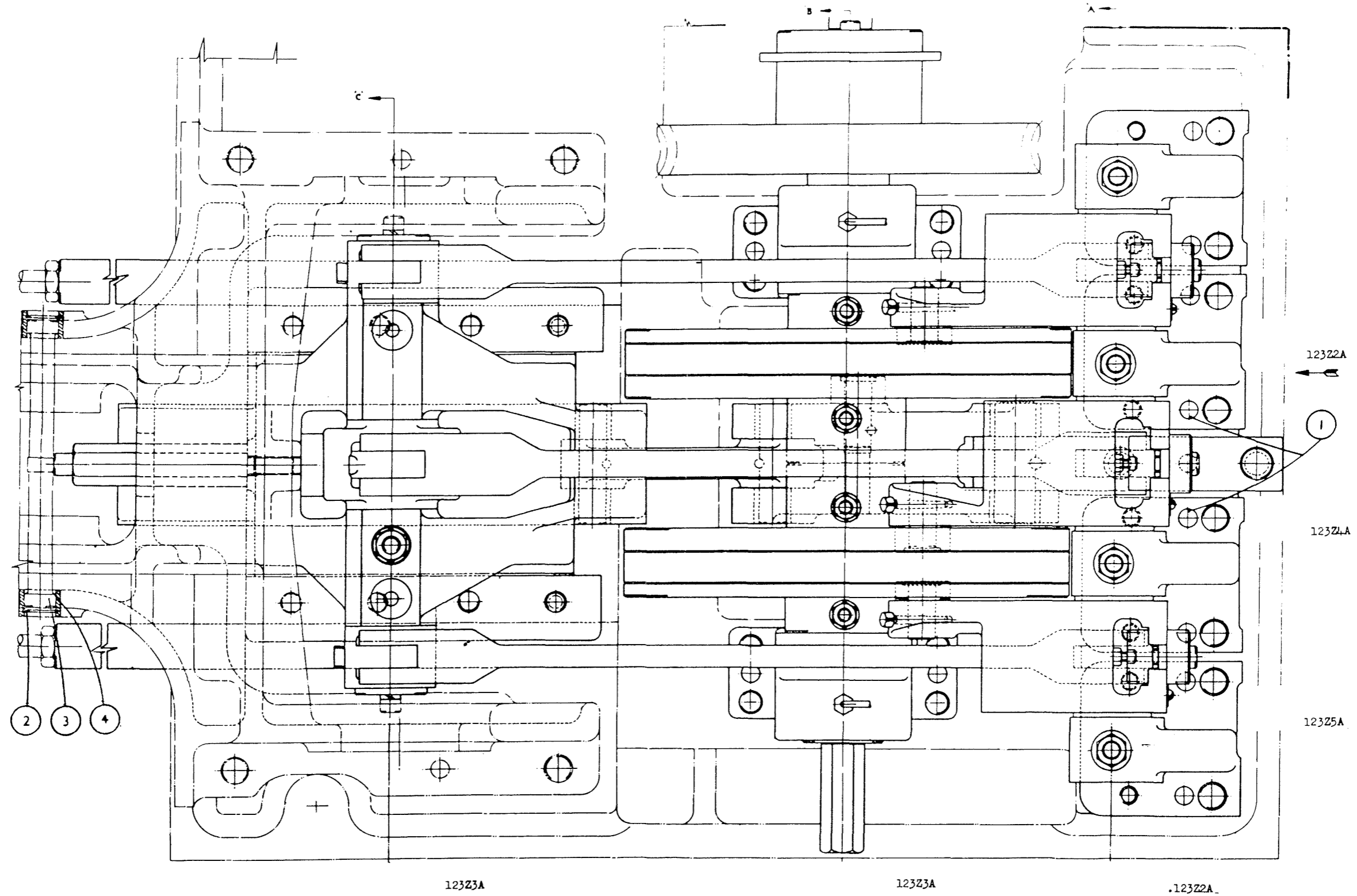

123 Z 1A LONGITUDINAL MOTIONS

Drg No.123Z2A ----- Longitudinal Motions - End View and Lever Bracket

1.	124X116	Roller Pin for Independent Levers
2.	139/4	1/4" Square Head Taper Pin
3.	124X117	Roller for Independent Cam Lever
4.	125Z101A	Independent Cam Lever (Rear)
5.	123X115	Bush
6.	CT18	Oilite Bush 7/16" long
7.	123Z102B	Centre Cam Lever
8.	123X103	Roller Pin
9.	139/4	1/4" Square Head Taper Pin
10.	123X104	Roller
11.	124X117	Roller for Independent Cam Lever
12.	139/4	1/4" Square Head Taper Pin
13.	124X116	Roller Pin for Independent Levers
14.	124Z101B	Independent Cam Lever (Front)
15.	123X109	Fulcrum Pin
16.	123X110	Quadrant Bush
17.	CT18	Oilite Bush 7/16" long
18.	173/081	1/2" B.S.F. Hexagon Locknut
19.	182/0824	1/2" B.S.F. Socket Head Set Screw Taper Point 1.1/2" long
20.	124X106	Fulcrum Pin
21.	123X110	Quadrant Bush
22.	123Y106A	Fulcum Bracket
23.	168X179	Oil Pipe Extension
24.	154/08	1/2" Spring Washer
25.	155/0828	1/2" B.S.F. Socket Head Cap Screw 1.3/4" long
26.	210/1725	Indicator Washer
27.	154/08	1/2" Spring Washer
28.	155/0864	1/2" B.S.F. Socket Head Cap Screw 4" long
29.	23Y107B	Fulcrum Bracket
30.	123Y106A	Fulcrum Bracket
31.	123Y107A	Fulcrum Bracket
32.	124X.104A	Stroke Setting Block
33.	165/206	2BA Round Head Slotted Screw 3/8" long
34.	23X105B	Scale
35.	123X111A	Stroke Setting Block
36.	165/206	2BA Round Head Slotted Screw 1.3/4" long
37.	23X105B	Scale
38.	124X104A	Stroke Setting Block
39.	165/206	2BA Round Head Slotted Screw 3/8" long
40.	123X105B	Scale
41.	155/0828	1/2" B.S.F. Socket Head Cap Screw 1.3/4" long
42.	154/08	1/2" Spring Washer

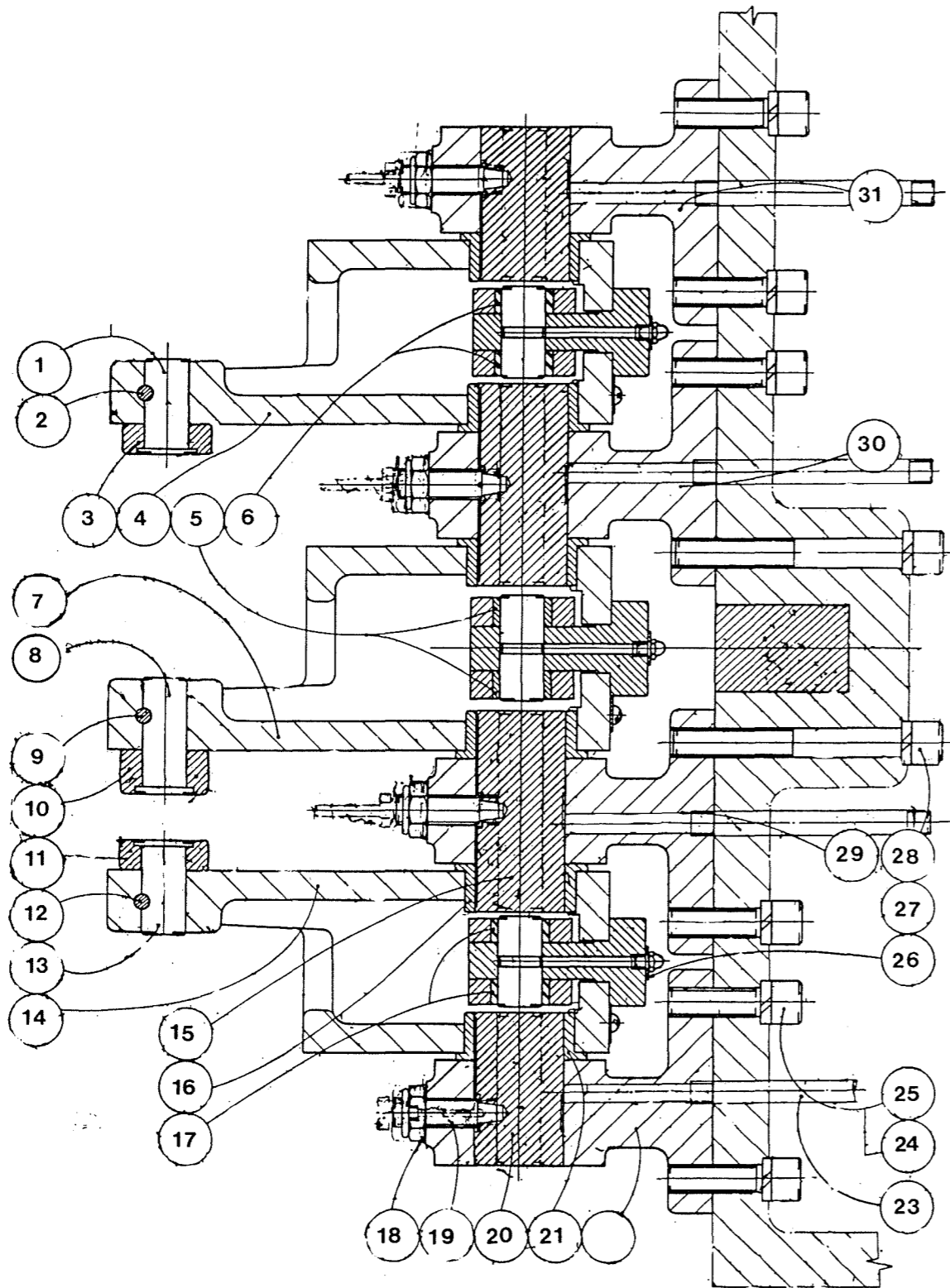

SECTIONAL VIEW THRO' LEVER PIVOTS ON 'AA' (1232 1A)

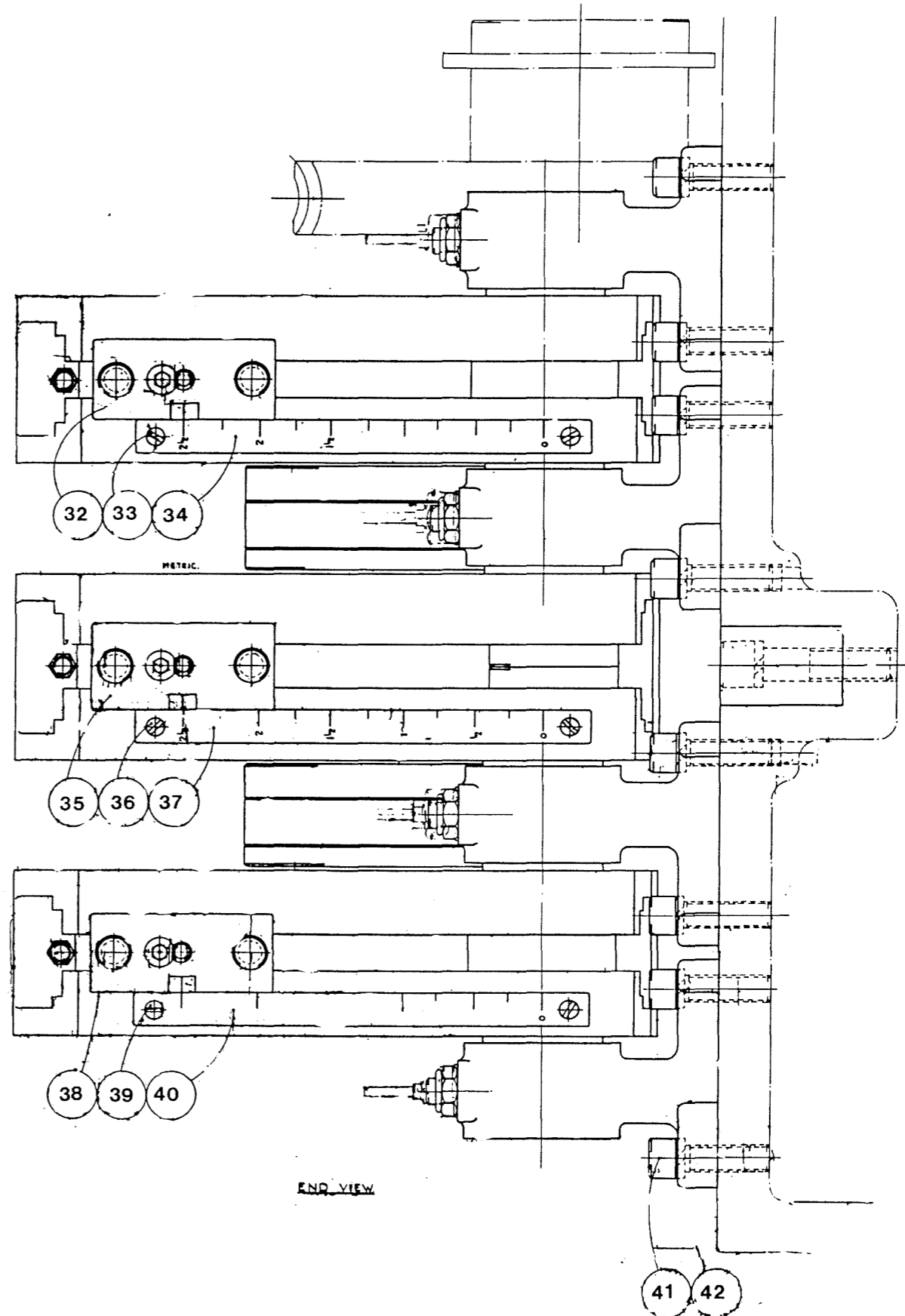

END VIEW

Drg No.123Z3A ----- Longitudinal Motions - Camshaft and Link Pivots

1.	124Y119A	Side Lever
2.	143/0610D	3/16" dia. Pin 5/8" long
3.	154/06	3/8" dia. Spring Washer
4.	155/0616	3/8" B.S.F. Socket Head Cap Screw 1" long
5.	123X166	End Plate
6.	236/202428	Oil Retaining Bush 1.1/4" x 1.1/2" x 1.3/4" long
7.	125/1624	1/4" dia. Taper Pin 1.1/2" long
8.	124X120	Link Pin for Side Levers
9.	CT18	Oilite Bush 7/16" long
10.	123Z101B	Sliding Block
11.	236/202416	Oil Retaining Bush 1.1/4" x 1.1/2" x 1" long
12.	123X162	Link Pin
13.	123X115	Bush
14.	125/1628	1/4" Taper Pin 1.3/4" long
15.	173/08L	1/2" B.S.F. Hexagon Locknut
16.	182/0820	1/2" B.S.F. Socket Head Set Screw Taper Point 1.1/4" long
17.	124X120	Link Pin for Slide Levers
18.	CT18	Oilite Bush 7/16" long
19.	125/1624	1/4" Taper Pin 1.1/2" long
20.	124Y119A	Side Lever
21.	236/202428	Oil Retaining Bush 1.1/4" x 1.1/2" x 1.3/4" long
22.	123X123	Shaft
23.	123X150A	Retaining Strip
24.	154/06	3/8" Spring Washer
25.	155/0628	3/8" B.S.F. Socket Head Cap Screw 1.3/4" long
26.	125/1628	3/4" dia. Taper Pin 1.3/4" long
27.	123X115	Bush
28.	123X162	Link Pin
29.	123Y122A	Centre Lever
30.	123X150A	Retaining Strip
31.	119X102A	Clamp Pillar
32.	119X106A	Clamp Plate
33.	123X131	Key for Worm Wheel
34.	118Y125A	Upper Worm Wheel
35.	123Y130A	Camshaft Bearing
36.	221/3	3/16" Enots Tubing Sleeve Z2
37.	215/3	3/16" Enots Tubing Nut Z24
38.	FX.5368A	Taper Pin on Camshaft
39.	173/06L	3/8" B.S.F. Hexagon Locknut
40.	125Y105	Long Slide Outer Cam 4th Station
41.	125Y104	Long Slide Feed cam 4th Station
42.	201X173	Dowel
43.	123Y185	Sliding Block Cam 2.1/2" F.M. Inner
44.	123Y186	Sliding Block Cam 2.1/2" F.M. Outer
45.	123Y187	Sliding Block Cam 2.1/2" F.M. Guard
46.	123Y182	Sliding Block Cam 2" F.M. Inner
47.	123Y183	Sliding Block Cam 2" Outer
48.	123Y184	Sliding Block Cam 2" F.M. Guard
49.	155/0714	7/16" B.S.F. Socket Head Cap Screw 7/8" long
50.	123Y180	Centre Block Feed Cam
51.	123Y181	Centre Block Outer Cam
52.	155/0512	5/16" B.S.F. Socket Head Cap Screw 3/4" long
53.	124Y122	Longslide Feed Cam 5th Station
54.	124Y123	Longslide Outer Cam 5th station
55.	124X121	Dowel
56.	123Y130A	Camshaft Bearing

57.	119X102A	Clamp Pillar
58.	201X173	Dowel
59.	126/1622	1/2" dia. Parallel
60.	155/0714	7/16" B.S.F. Socket Head Cap Screw 7/8" long
61.	123Y152D	Cam Carrier (Front)
62.	123Y153D	Cam Carrier (Rear)
63.	124X121	Dowel
64.	155/0512	5/16" B.S.F. Socket Head Cap Screw 3/4" long
65.	141/13	1/2" dia. Taper Pin 1.3/4" long
66.	154/07	7/16" dia. Spring Washer
67.	155/0728	7/16" B.S.F. Socket Head Cap Screw 1.3/4" long
68.	119X200A	Cam Ring
69.	154/06	3/8" Spring Washer
70.	155/0620	3/8" B.S.F. Socket Head Cap Screw 1.1/4" long

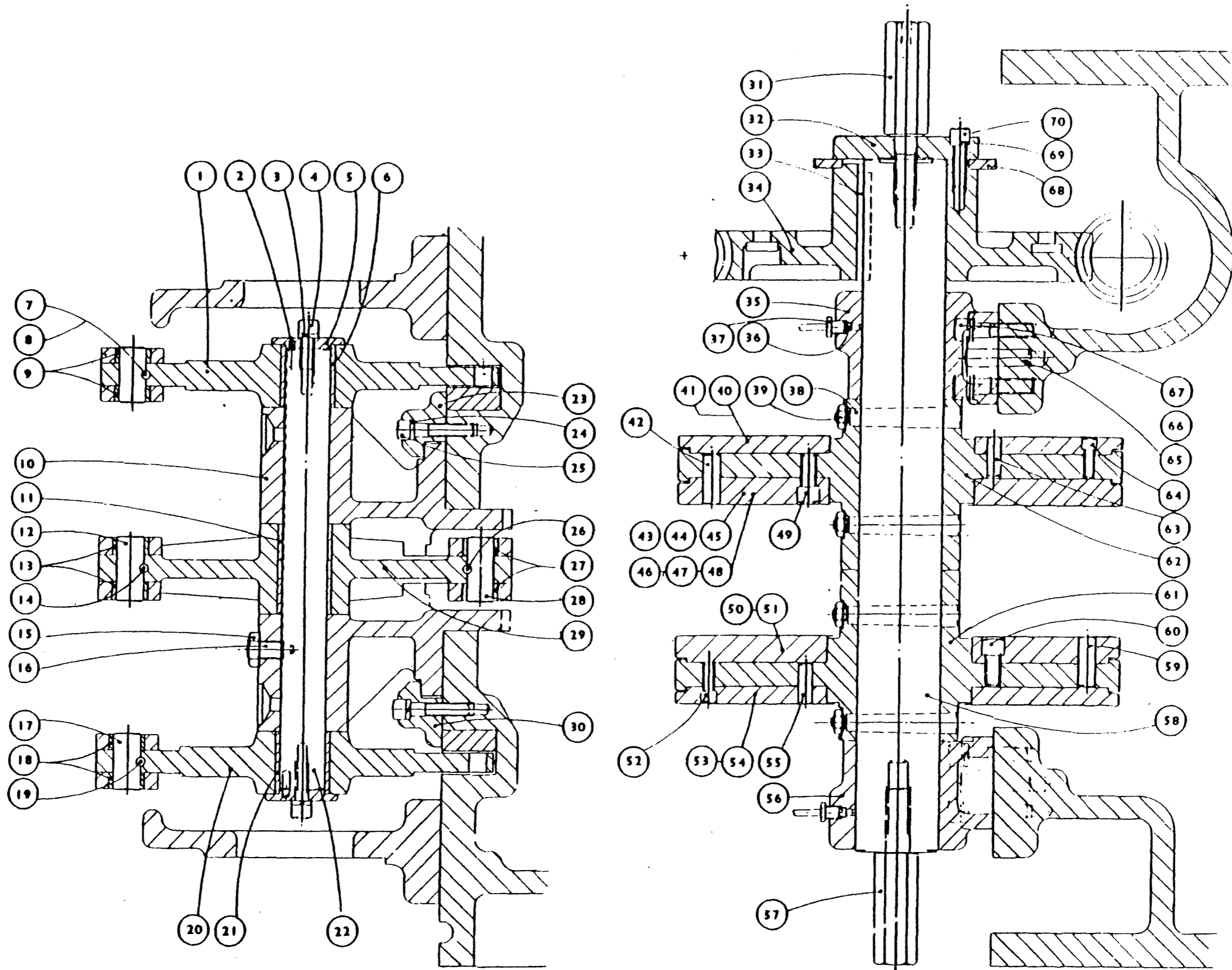

123 Z 3A

LONGITUDINAL MOTIONS - CAMSHAFT AND LINK PIVOTS

Drg No.123Z4ALongitudinal Motions - Centre & Sliding Block

1.	123X165	Bush
2.	123X165	Bush
3.	123X104	Roller
4.	123X174	Bush in Toggle Lever
5.	125/2232	1 1/32" dia. Taper Pin 2" long
6.	123Y116	Link for Centre Cam Lever
7.	123X118	Link Pin
8.	123X165	Bush
9.	125/1628	1/4" dia. Taper Pin 1.3/4" long
10.	123X161	Toggle Link
11.	125/1628	1/4" dia. Taper Pin 1.3/4" long
12.	123X165	Bush
13.	123X118	Link Pin
14.	123Y119A	Toggle Lever
15.	123X103	Roller Pin
16.	125/1624	1/4" dia. Taper Pin 1.1/2" long
17.	123X174	Bush in Toggle Lever
18.	123X168	Pin for Toggle Lever
19.	173/04	1/4" B.S.F. Hexagon Nut
20.	155/0414	1/4" B.S.F. Socket Head Cap Screw 7/8"
21.	123X113A	Clamp
22.	182/0510	5/16" Socket Head Set Screw Taper Point
23.	212/04	1/4" B.S.F. Autolub Nipple
24.	123X114	Link Pin
25.	155/0724	7/16" B.S.F. Socket Head Cap Screw 1.1/2"
26.	154/07	7/16" Spring Washer
27.	See 123Z2A	
28.	123X160	Toggle Anchor
29.	139/27	5/8" dia. Headed Taper Pin
30.	155/1044	5/8" B.S.F. Socket Head Cap Screw 2.3/4"
31.	154/10	5/8" Spring Washer
32.	123X173	Adjusting Washer (2.1/2" F.M.)
33.	113X173	Adjusting Washer (2.1/2" F.M.)
34.	123X171	Stop Screw (2" F.M.)
35.	123Y120	Link (Centre Block)
36.	123X175C	Drip Tray
37.	154/04	1/4" Spring Washer
38.	155/0410	1/4" B.S.F. Socket Head Cap Screw 5/8" long
39.	123X114	Link Pin
40.	127Y102	Guide Arm
41.	123X140	Stop Screw
42.	123X169	Stop Screw
43.	123X170	Adjusting Washer
44.	122Z104	Beam
45.	123X178	Stop Pad
46.	123X176	Stop Bolt

FIRST USED ON			
LAST USED ON			
SUPPLIERS			
SUPERSEDED BY			
ALTERATIONS			
U & B LIMIT HOLE TO S 164 1941			
REMOVE ALL SHARP COR UNLESS OTHERWISE STA			
TOLERANCE ON MACHIN DIMENSIONS: DID UNL; OTHERWISE STATED			
AMERICAN PROJECTION			
F ROUGH MACHIN			
FINISH MACHIN			
GRIND OR			
COLUMELLA			
RAW MATERIAL No			
SCALE	125	1" = 6	MADE ON IN AT
DRAWN	124	1" = 6	DRG No
CHECKED	123	1" = 6	
RE-TRACED			
TRAJING CHECKED			
J.C.			
J.C.			

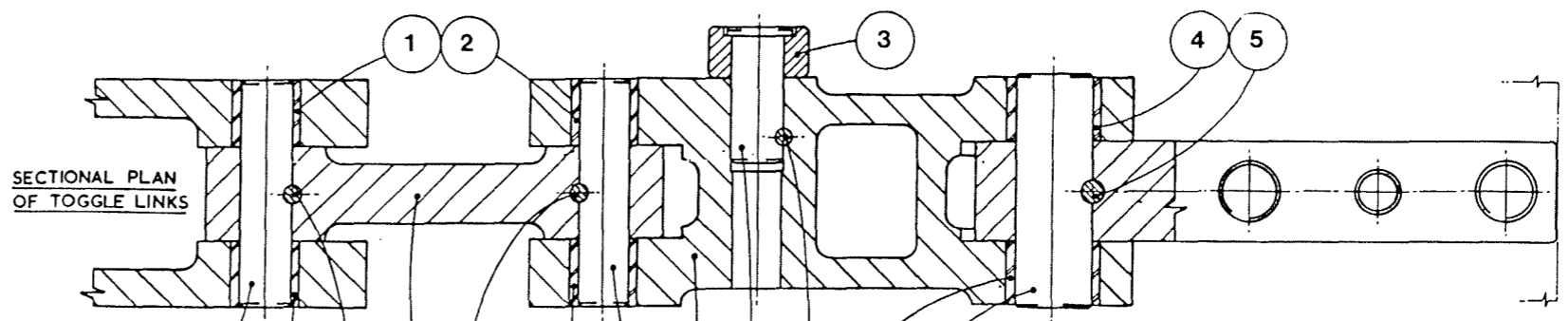

ADJUST SO THAT STOP BOLT DEFLECTS BAR (41X159) .025' WHEN SLIDING BLOCK IS FULLY FORWARD.

FITTER: NOTE POSITION OF MACHINING

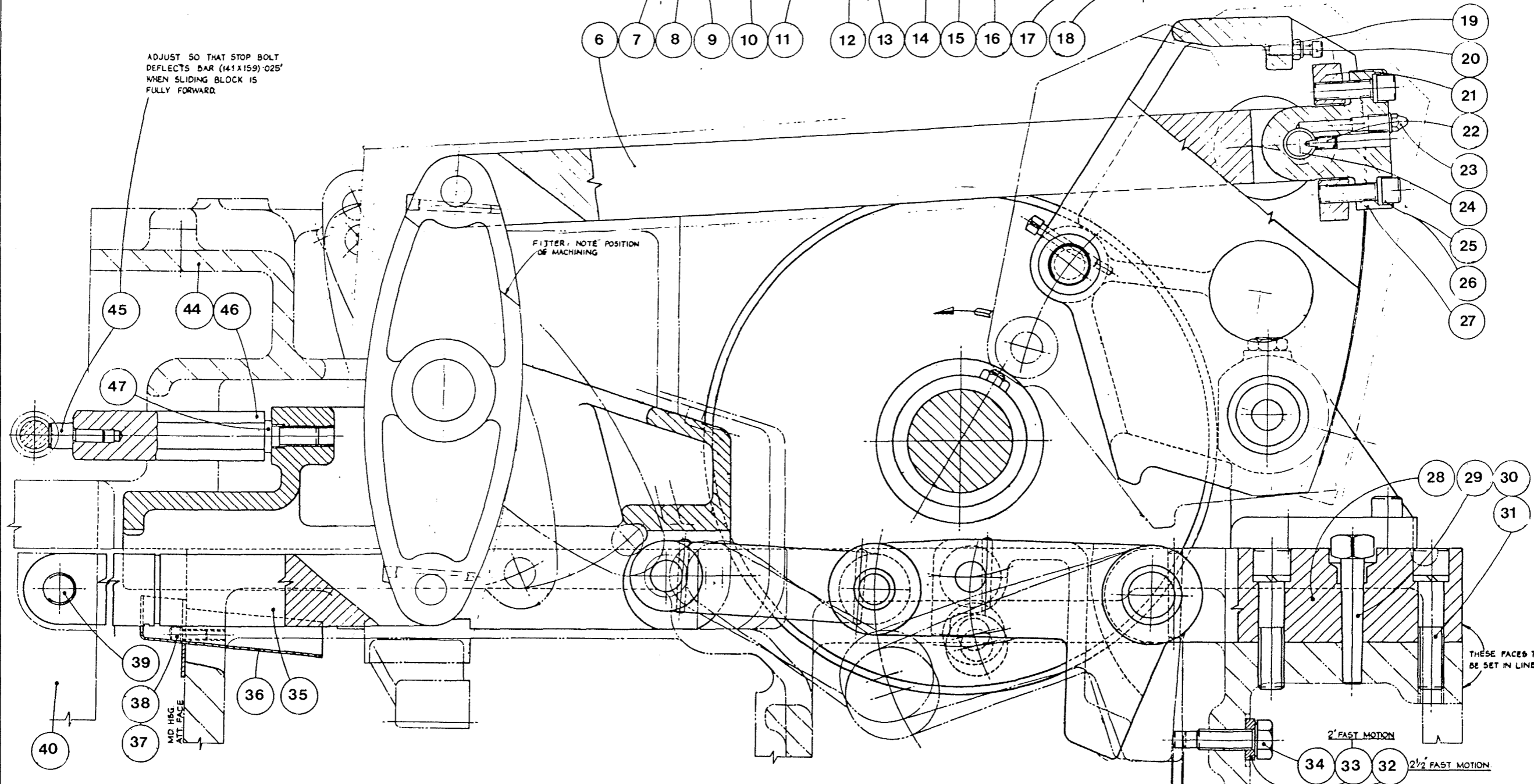

THESE FACES TO BE SET IN LINE

ADJUST SPACERS 123 X 172 AND 123 X 173 TO GIVE .005'/.010' CLEARANCE AS INDICATED BETWEEN BOLT & TOGGLE

2' FAST MOTION
2 1/2' FAST MOTION

ARR. OF LONGITUDINAL MOTIONS CENTRE & SLIDING BLOCK MECHANISM

SCALE	125	1" = 6	MADE ON IN AT
DRAWN	124	1" = 6	DRG No
CHECKED	123	1" = 6	
RE-TRACED			
TRAJING CHECKED			
J.C.			
J.C.			

Drg No.123Z5A Longitudinal Motions - Independent Slides

1. 124Y105 Link for Cam Levers
2. 173/04 1/4" B.S.F. Hexagon Nut
3. 155/0414 1/4" B.S.F. Socket Head Cap Screw 7/8" long.
4. 124X113 Nut for Stroke Adjustment Blocks
5. 154/07 7/16" Spring Washer
6. 155/0724 7/16" B.S.F. Socket Head Cap Screw 1.1/2" long
7. 212/04 1/4" B.S.F. Autolub. Nipple
8. 182/0510 5/16" B.S.F. Socket Head Set Screw Taper Point
7/8" long.
9. 124X109 Fulcrum Pin
10. See 123Z2A
11. See 123Z2A
12. See 123Z3A
13. See 123Z3A
14. 122Z105A Main Drive Housing
15. 124Y112A Pusher Arm
16. 129X107 Adjusting Screw
17. 122Z104 Beam

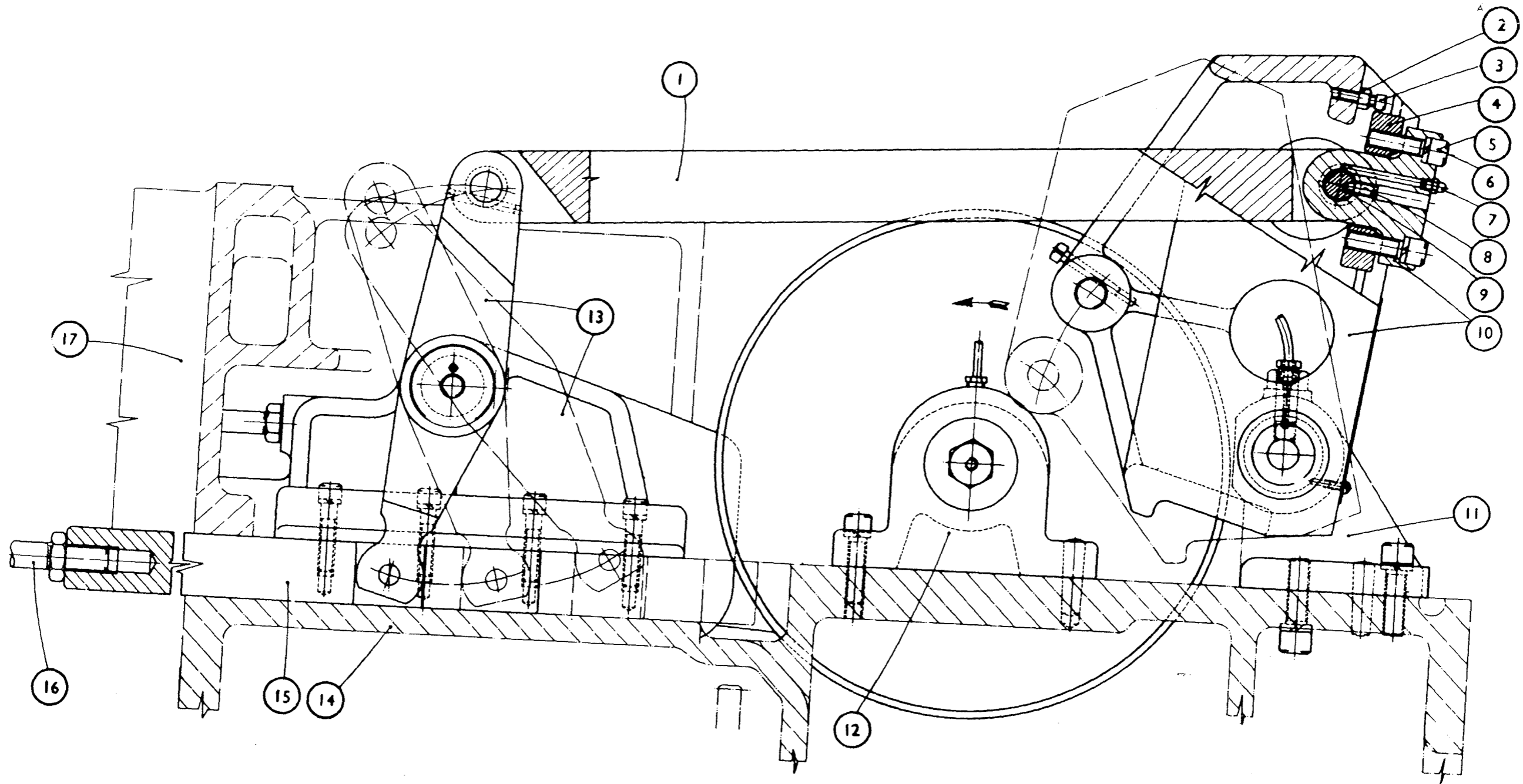

Drq No.127Z1B ----- Centre Block and Longitudinal Slides

1.	FX4539C	Gib Adjusting Screw
2.	132X103	Gib Strip for Rear Tool Block
3.	129X105	Locating Block
4.	129Y102B	Tool Slide Guide
5.	127V105	Guide Block
6.	127X107	Adjusting Nut
7.	127X106	Gib Strip
8.	155/0414	1/4" B.S.F. Socket Head Cap Screw 7/8" long
9.	154/04	1/4" Spring Washer
10.	155/0648	3/8" B.S.F. Socket Head Cap Screw 3" long
11.	154/06	3/8" Spring Washer
12.	127X104A	Guide Strip
13.	154/07	7/16" dia. Spring Washer
14.	155/0748	7/16" B.S.F. Socket Head Cap Screw 3" long
15.	129X109	Stop Block
16.	188/0632	3/8" B.S.F. Square Head Set Screw 2" long
17.	129X108A	Stop Nut
18.	127X120	Centre Guide Swarf Guard
21.	181/206	2BA Socket Set screw 1/2" dog point 3/8" long
22.	129X112	Locknut
23.	129X110	Spacer
24.	154/06	Spring Washer
25.	155/0640	3/8" B.S.F. Socket Head Cap Screw 2.1/2" Long
26.	182/0512	5/16" B.S.F Socket Set Screw Taper Point 3/4" Long
27.	181/206	2BA Socket Set Screw 1/2 dog point 3/8" long
28.	129X107	Adjusting Screw
29.	129X112	Locknut
30.	168X104A	For Vogel Parts, see 168Z17
31.	178/0514	5/16" B.S.F Socket Set Screw 7/8" Long
32.	194/1	Plug
33.	155/0516	5/16" Socket Head Cap Screw 1" long
34.	154/05	S.P.ST Washer
35.	154/06	3/8" Spring Washer
36.	155/0632	3/8" Socket Head Cap Screw 2" Long
37.	132Y101A	Tool Block (Rear)
38.	129Y101A	Tool Block (Front)
39.	129Y102B	Tool Slide Guide
40.	129X103	Gib Strip for Front Tool Block
41.	154/07	7/16" Spring Washer
42.	155/0724	7/16" B.S.F Socket Head Cap Screw 1.1/2" Long
43.	158/0410	1/4" B.S.F Socket Countersunk Head Screw 5/8" Long
44.	127X124	Beam Swarf Guard
45.	129X111	Stop Nut Carrier
46.	154/03	3/16" Spring Washer
47.	156/216	2BA Socket Head Cap Screw 1" long
48.	173/06H	3/8" B.S.F Hex. Nut
49.	129X106A	Extension Arm
50.	173/06/H	3/8" B.S.F Hex. Locknut
51.	194/1	1/8" BSP Plug
52.	194/1	1/8" BSP Plug
53.	147/0402	4mm 1/8" BSP Taper
54.	140704	Tubing 4mm
55.	140804	Olive 4mm
56.	127X111A	Stop Screw

57.	173/06H	3/8" B.S.F Hex. Nut
58.	127X115	Dowel
59.	127X113A	Scraper Rings
60.	159/210	2BA Socket Head Set Screw 5/8" Long
61.	127X114	Retaining Plate
62.	127X112A	Backing Plate
63.	127X103A	Bush for Centre Block
64.	127Y101B	Centre Block
65.	194/1	1/8" BSP Plug
66.	127X103A	Bush for Centre Block
67.	141/17	1/2" dia. Taper Pin 3" Long
68.	127X102E	Guide Arm
69.	155/0744	7/16" B.S.F Socket Head Cap Screw 2.3/4" Long
70.	154/07	7/16" S.P.ST Washer

FIRST ISSUE ON
LAST ISSUE ON
SUPERSEDES
127 Z1 A.
DESIGNED BY
ALTERATIONS
(A) 100A12L R.S. 2.0.53
(B) 100A13S R.S. 18.5.54
(C) 100A308 L.P.M. 8.2.58
(D) 100A356 B.T.P. 16.10.59
(E) 100A382 H.J.G. 24.7.61
(F) 100A424 A.D.H. 9.1.63
(G) 100A447 B.M. 1.10.64
(H) 100A459 B.M. 5.4.66
(I) 400A246 H.J.G. 4.3.67
(J) 100A551 R.S. 4.12.73
(K) 100A579 J.C.W. 4.8.78
(L) 100A584 G.C. 25.4.78
(M) 100A601 B.M. 14.8.80
(N)

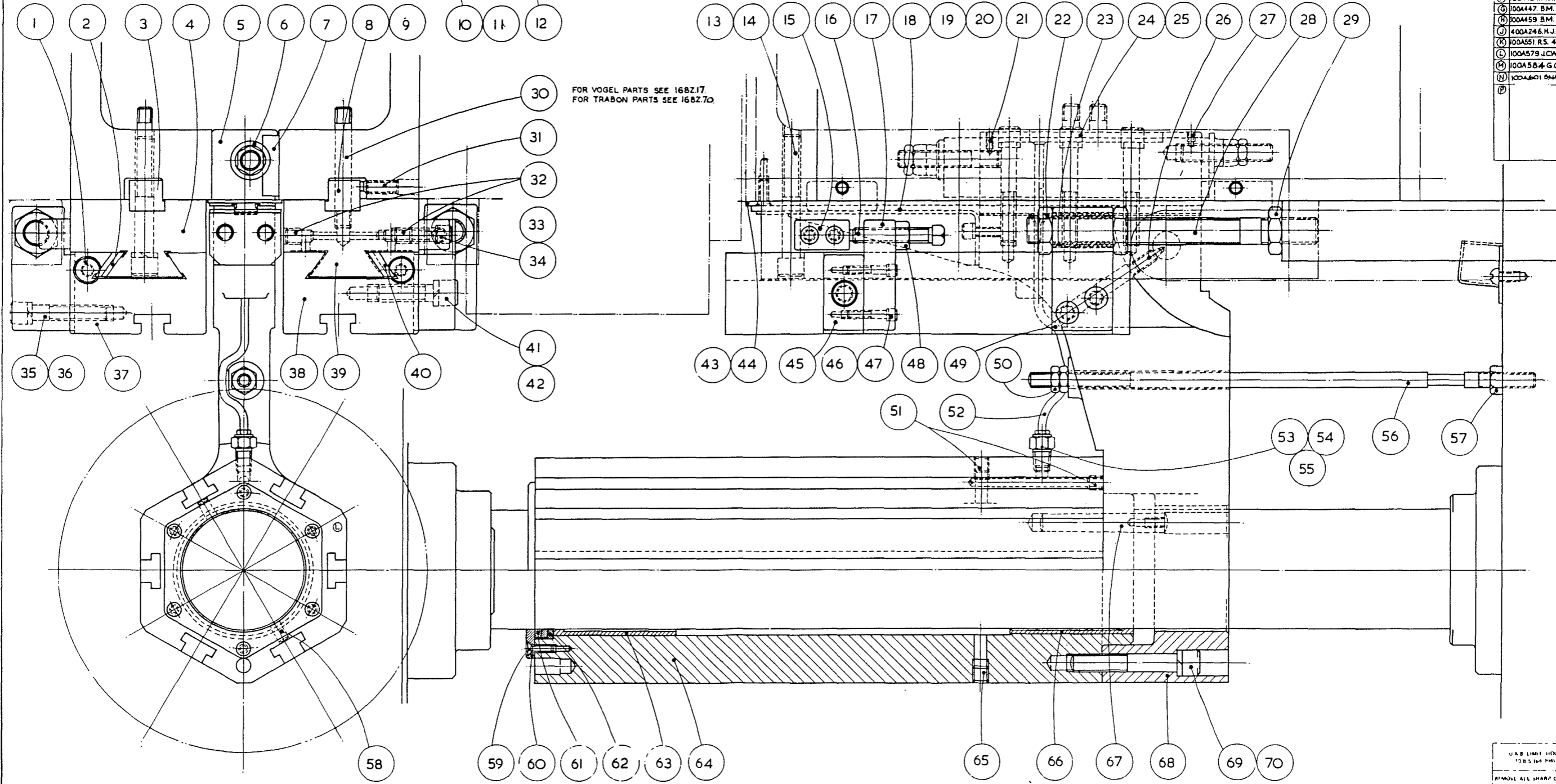
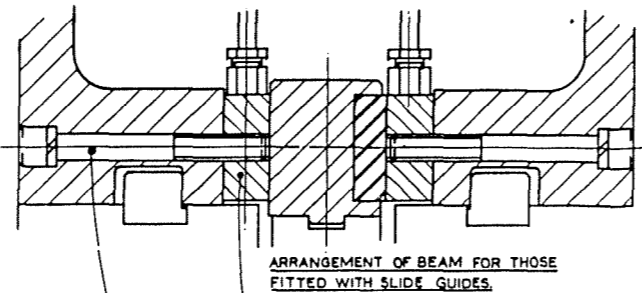

ARR. OF CENTRE BLOCK & LONGITUDUAL SLIDES

SEE 12722 FOR PLAN VIEW

U.S. LIMIT DIMS (28.5.1963)
REMOVE ALL SHARP CORNERS UNLESS OTHERWISE STATED
TOLERANCES ON MACHINING DIMENSIONS UNLESS OTHERWISE STATED
AMERICAN PREFERENCE
F. FINISH OFF MACHINE
FF. FINISH MACHINE
FFF. GRIND OR EQUIVALENT
RAWMATERIAL AT THE



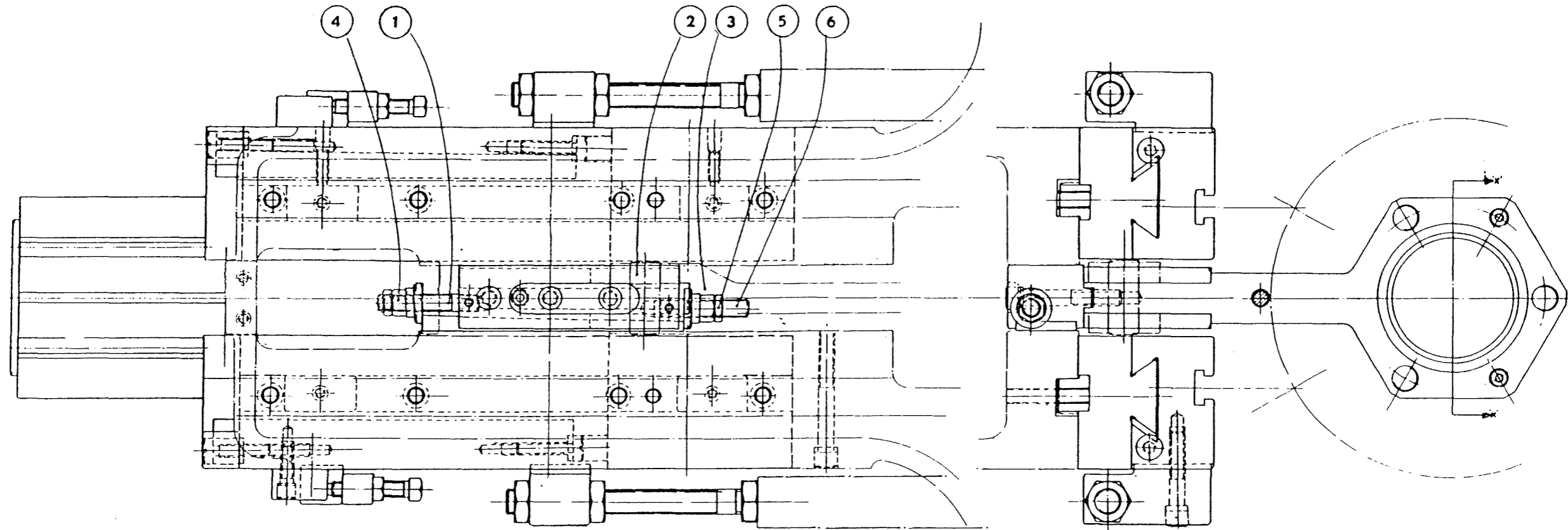

127 Z 2A CENTRE BLOCK AND LONGITUDINAL SLIDES

Drg No. 135Z2 Upper Cross Slide Arrangement

1.	236/242820	Oil Retaining Bush 1.1/2" x 1.3/4" x 1.1/4" long
2.	254X101	Adaptor
3.	135X225	Shaft
4.	Assembly	Instructions
5.	155/0410	1/4" B.S.F. Socket Head Cap Screw 5/8" long
6.	FX4539C	Gib Adjusting Screw
7.	142X126A	Pad Bush
8.	142X113	Gib Strip
9.	142X143A	Pad Bolt
10.	142X125A	Pad Bush
11.	155/0624	3/8" B.S.F. Socket Head Cap Screw 1.1/2" long
12.	155/0428	3/8" B.S.F. Socket Head Cap Screw 1.3/4" long
13.	135X206	Spring Stop
14.	135X210	Spring Plunger
15.	135X109	Compression Spring
16.	135Z202A	Upper Cross Slide
17.	135Z201A	Upper Cross Slide Base
18.	136X106B	Stop Bracket
19.	136X115A	Peg
20.	136V114A	Fork Lever
21.	136X128	Pin
22.	236/121612	Oil Retaining Bush 3/4" x 1" x 3/4" long
23.	136X128	Pin
24.	155/0520	5/16" B.S.F. Socket Head Cap Screw 1.1/4" long
25.	183/0620	3/8" BSF Sq. Head Set Screw Taper Point 1.1/4" long
26.	203/06L	Nylon Lock Nut 5/16" B.S.F.
27.	141/3	Extractable Taper Pin 11/32" x 1.1/4" long
28.	135X216	Bush
29.	135X119B	Fork Lever
30.	136X117	Link
31.	183/0516	Sq. Head Set Screw Taper Point 5/16" BSF x 1" long
32.	203/05L	Nylon Lock Nut (Thin) 5/16" B.S.F.
33.	203/06L	Nylon Lock Nut (Thin) 3/8" B.S.F.
34.	142V112M	Adjusting Bolt Head
35.	142V112E	Adjusting Bolt Head
36.	135V238	Cross Slide Nut
37.	182/0612	3/8" B.S.F. Socket Set Screw Taper Point 3/4" long
38.	144/05	Nylon Pad 6mm dia. x 1/4" long.
39.	188/0512	5/16" B.S.F. Square Head Set Screw 3/4" long
40.	135V239	Adjusting Bolt
41.	135X120B	Fork Lever
42.	142X124D	Stop Bracket Screw
43.	173/05H	5/16" B.S.F. Nut Cyn. Hardened
44.	142X123C	Stop Bracket Bush
45.	136X105B	Stop Bracket
46.	194/1	1/8" B.S.P. Plug
47.	155/0628	3/8" B.S.F. Socket Head Cap Screw 1.3/4" long
48.	141/4	11/32" x 1.3/4" long Taper Pin
49.	136X128A	Pin
50.	236/121608	Oil Retaining Bush 3/4" x 1" x 1.1/2" long
51.	236/121612	Oil Retaining Bush 3/4" x 1" x 3/4" long
52.	101/18	Ext. Circlip 1.1/2" dia.
53.	117/112	Adjusting Washer
54.	236/242836	Oil Retaining Bush 1.1/2" x 1.3/4" x 2.1/4" long
55.	179/203	2BA Socket Set Cup Point 3/16" long
56.	155/0516	5/16" B.S.F. Socket Head Cap Screw x 1" Long
57.	194/1	1/8" BSP Plug
58.	183/0616	3/8" B.S.F. Sq. Head Set Screw Taper Point x 1" Long

Drg No. 135Z2 Upper Cross Slide Arrangement

59. Apply Loctite grade to relief on underside of slide base 135Z201 to provide coolant proof seal with beam.
60. Apply Loctite to screw thread on assembly.
61. Adjust slide faces to these dimensions. Remove all sharp corners after adjusting.

SUPERSEDES	135Z/A
SUPERSEDED BY	135Z/1
ALTERATIONS	

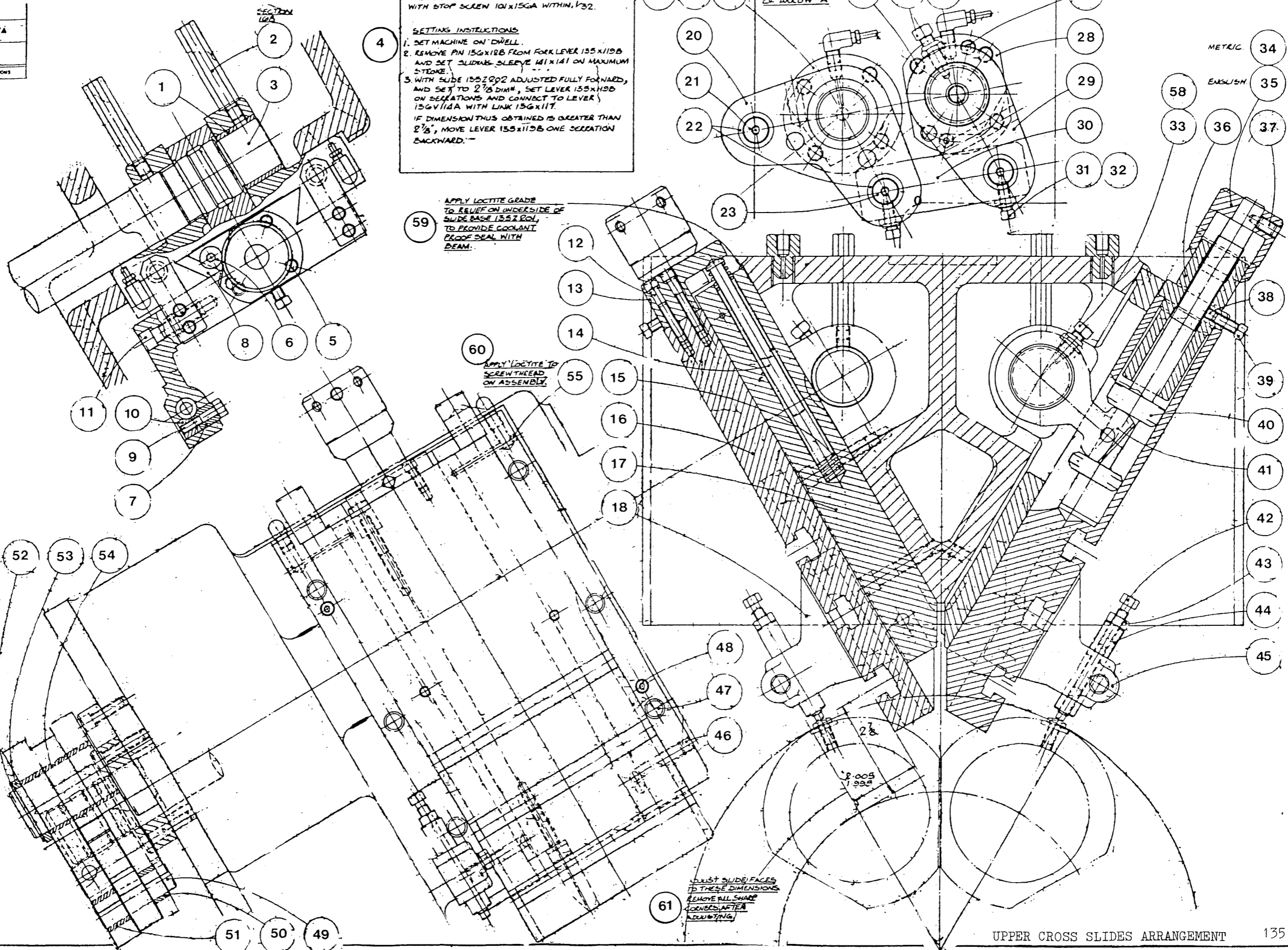

Drq No.137Z1B ----- 6th Station Cut-off Slide

1.	137X156	Fork Lever
2.	236/101207	Oil Retaining Bush 9/16" x 13/16" x 7/16"
3.	137CX108	Pin for Connecting Link
4.	182/0616	3/8" B.S.F. Socket Set Screw Taper Point 1" long
5.	137X122	Bearing for Bar Stop & Cross Slide Operating Tube
6.	137Y157	Slide Operating Tube
7.	155/0624	3/8" B.S.F. Socket Head Screw 1.1/2" long
8.	154/06	3/8" Spring Washer
9.	155/0616	3/8" B.S.F. Socket Head Cap Screw 1" long
10.	154/06	3/8" Spring Washer
11.	155/0514	5/16" B.S.F. Socket Head Cap Screw 7/8" long
12.	154/05	5/16" Spring Washer
15.	137Z151	Cut-off Slide Base
16.	177/0404	1/4" B.S.F. Socket Set Screw Cone Point 1/4" long
18.	137V165/M	Micrometer Head (Metric)
19.	137V165/E	Micrometer Head (English)
20.	137X161	Adjusting Screw
21.	137X162	Spacer
22.	101/10	External Circlip 15/16" dia.
23.	125/0814	1/8" dia. Taper Pin
24.	137Y152	Cut-off Slide
25.	137/07H	7/16" B.S.F. Hexagonal Nut
26.	130/07	7/16" dia. Washer
27.	137X158	Gib Adjusting Screw
28.	225/3050	3/16" o.d. Copper Pipe 5/16" long
29.	137X118	Compression Spring
30.	144X146	Spring Support
31.	236/070908	Oil Retaining Bush 7/16" x 9/16" x 1/2"
32.	137X164	Link Pin
33.	212/04	1/4" B.S.F. Autolub Nipple
34.	137Y153	Cut-off Slide Gib Strip
35.	137X154A	End Bracket
36.	137X159A	Adjusting Block
37.	137X160	Slide Bolt
38.	137X163A	Link
39.	122/1216T	Key
40.	137X155	Operating Arm
41.	155/0624	3/8" B.S.F. Socket Head Cap Screw 1.1/2" long
42.	154/06	3/8" Spring Washer
43.	155/0616	3/8" B.S.F. Socket Head Cap Screw 1" long
44.	154/06	3/8" Spring Washer
45.	141/6	13/32" dia. Taper Pin 1.1/2" long
46.	137X166	Chip Cover
47.	159/406	4BA Socket Countersunk Screw 3/8" long
48.	137X170	Guard
49.	155/0408	1/4" B.S.F. Socket Head Cap Screw 1/2" long
50.	137X138	Spring

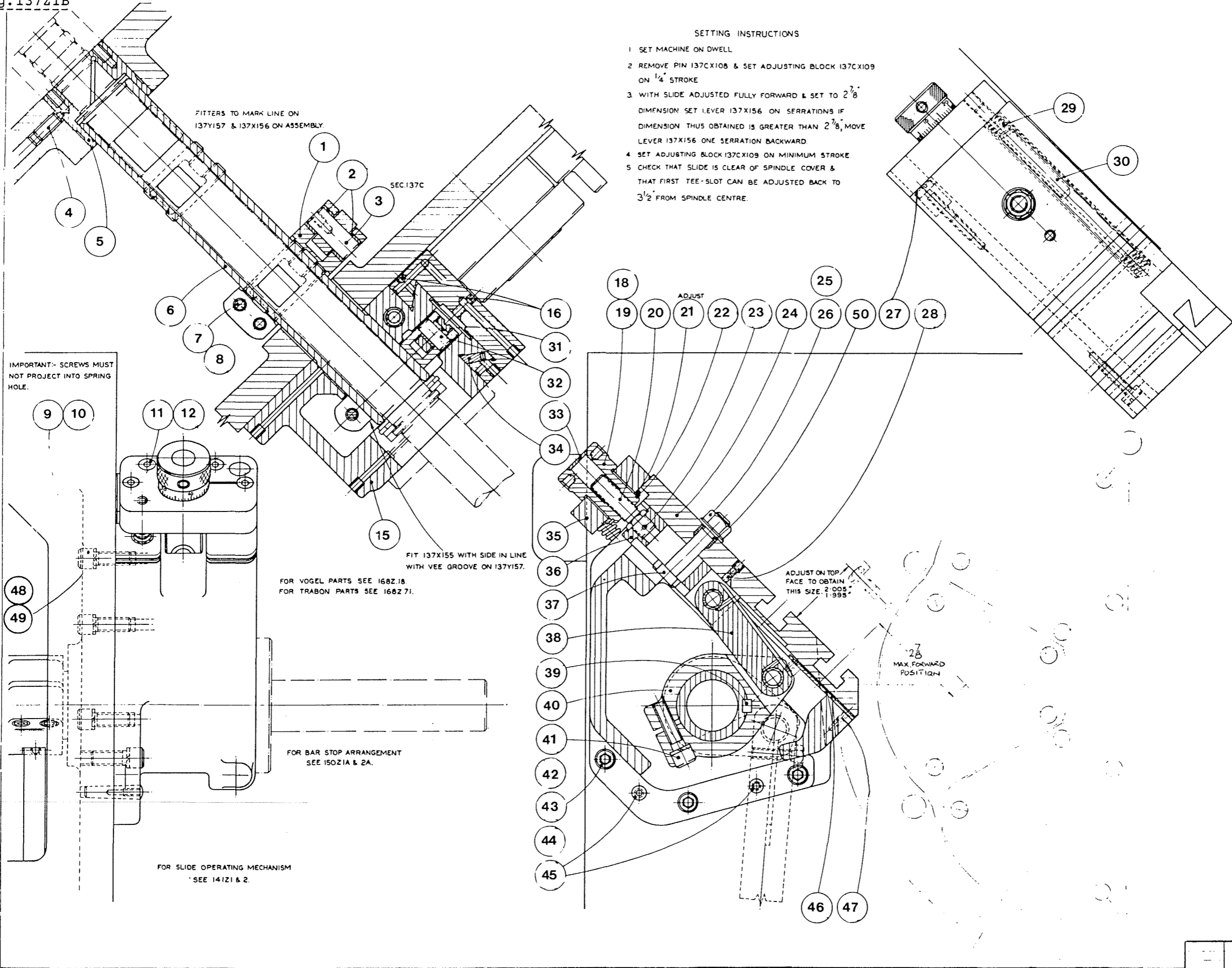

SCALE	DRAWN BY	CHKD BY	DATE	NO.	ARRANGEMENT	SECTION	MACHINE	137	1-6	137Z1B
FULL SIZE	PLFR1/6	PLFR1/6	03/08/89							

AMERICAN
MACHINE
CO.
MILWAUKEE, WIS.

Drg No.139AZ1 3rd Station Cut-Off Slide

1.	144X146	Spring Support
2.	137X118	Spring for Cross Slide
3.	137X166	Chip Cover
4.	159/406	4BA Socket Countersunk Screw 3/8" long
5.	137X158	Gib Adjusting Screw
6.	142X124D	Stop Bracket Screw
7.	139X173B	Stop Bracket
8.	173/05H	5/16" B.S.F. Nut
9.	142X123C	Stop Bracket Bush
10.	210/1725	11/16" Yellow Indicating Washer
11.	212/04	1/4" B.S.F. Autolub Nipple
12.	137X163A	Link
13.	130/07	7/16" Washer
14.	173/07H	7/16" B.S.F. Hexagon Nut
15.	137X/160	Slide Bolt
16.	137X159A	Adjusting Block
17.	137X154A	End Bracket
18.	137X164	Link Pin
19.	236/070908	Oil Retaining Bush 1/2" x 7/16" x 9/16"
20.	225/3050	3/16" Enots Copper Pipe 5/16" long
21.	177/0404	1/4" B.S.F. socket Set Screw 1/4" long
22.	210/1725	11/16" Yellow Indicating Washer
23.	212/4504	1/4" B.S.F. Autolub Nipple
26.	155/0616	5/16" B.S.F. Socket Head Cap Screw 1.1/4" long
27.	154/06	3/8" Spring Washer
28.	139AX.157	Operating Tube
29.	236/101207	Oil Retaining Bush 5/8" x 3/4" x 7/16"
30.	137CX108	Pin for Connecting Link
31.	137X156	Fork Lever
32.	154/06	3/8" Spring Washer
33.	155/0624	3/8" B.S.F. Socket Head Cap Screw 1.1/2" long
34.	155/0514	5/16" B.S.F. Socket Head Cap Screw 7/8" long
35.	154/04	1/4" Spring Washer
36.	155/0616	5/16" B.S.F. Socket Head Cap Screw 1" long
37.	154/06	3/8" Spring Washer
38.	137X161A	Adjusting Screw
39.	139AY152	Cut-off Slide
40.	139AY153	Gib Strip
41.	137V165/M	Micrometer Head (Metric)
42.	137V165/E	Micrometer Head (English)
43.	139AZ151	3rd Station Cut-off Slide Base
44.	137X155	Operating Arm
45.	155/0624	3/8" B.S.F. Socket Head Cap Screw 1.1/2" long
46.	154/06	3/8" Spring Washer
47.	212/04	1/4" B.S.F. Autolub Nipple
48.	210/1725	11/16" Yellow Indicating Washer
49.	139AX174	Extractable Plug
50.	137X162	Spacer
51.	101/10	External Circlip 5/16" dia.
52.	125/0814	1/8" Taper Pin 7/8" long
53.	122/1216T	Key
54.	155/0620	3/8" B.S.F. Socket Head Cap Screw 1.1/4" long
55.	154/06	3/8" Spring Washer
56.	141/6	13/32" Taper Dowel 1.1/2" long
57.	167/0520	5/16" B.S.F. Hexagon Head Set Screw 1.1/4" long
58.	137CY105	Connecting Link
59.	137CX120A	Scale

61.	165/406	4BA Round Head Set Screw 3/8" long
62.	137CX107	Tee Bolt Plate
63.	137CX106	Tee Bolt Plate
64.	155/0420	1/4" B.S.F. Socket Head Cap Screw 1.1/4" long
65.	154/04	1/4" Spring Washer
66.	137CX109	Pin for Connecting Link
67.	155/0416	1/4" B.S.F. Socket Head Cap Screw 1" long
68.	137CX119	Tee Bolt
69.	137CX123	Bush for Connecting Link
70.	141X116	Slotted Washer
71.	173/10HL	5/8" B.S.F. Locknut
73.	142X125A	Pad Bush
74.	142X126A	Pad Bush
75.	142X143A	Pad Bolt
76.	137X170	Guard
77.	155/0408	1/4" B.S.F. Socket Head Cap Screw 1/2" long
78.	137X138	Spring

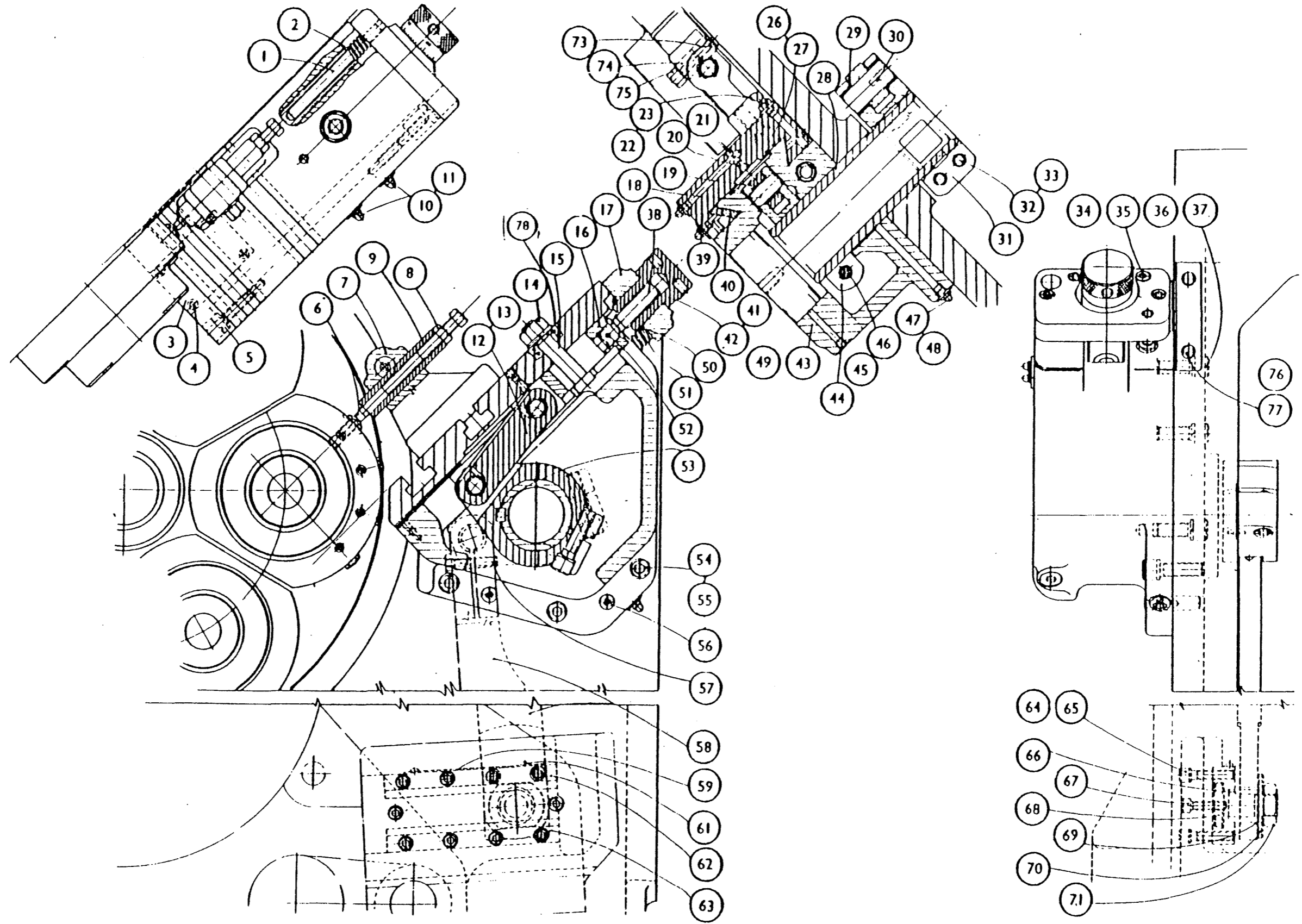

139AZ1

3RD STATION CUT OFF SLIDE

Drg No.139Z1B ----- 3rd Station Forming Slide

1.	139X166	Chip Cover
2.	159/406	4BA Socket Head Countersunk Screw 3/8" long
3.	137X158	Gib Adjusting Screw
4.	142X124D	Stop Bracket Screw
5.	139X173B	Stop Bracket
6.	173/05H	5/16" R.S.F. Nut
7.	142X123A	Stop Bracket Bush
10.	135X109	Compression Spring
11.	144X146	Spring Support
12.	139X163A	Link
13.	137X160	Slide Bolt
14.	173/07H	7/16" B.S.F. Hexagon Nut
15.	130/07	7/16" Washer
16.	139X159A	Adjusting Block
17.	125/0816	1/8" Taper Pin 1" long
18.	137X161A	Adjusting Screw
19.	139X154A	End Bracket
20.	139X164	Link Pin
21.	236/070910	Oil Retaining Bush 7/16" x 9/16" x 5/8"
22.	177/0404	1/4" B.S.F. Socket Set screw Cone Point 1/4" long
23.	225/3050	3/16" Enots Copper Pipe 5/16" long
29.	155/0624	1/8" B.S.F. Socket Head Cap Screw 1.1/2" long
30.	139X172	Operating Shaft Bearing
31.	236/101207	Oil Retaining Bush 5/8" x 3/4" x 7/16"
32.	137CX108	Pin for Connecting Link
33.	182/0616	3/8" B.S.F. Socket Set Screw Taper Point 1" long
34.	139X122	Bearing for Operating Shaft
35.	139Y157	Operating Shaft
36.	154/06	3/8" Spring Washer
37.	155/0624	3/8" B.S.F. Socket Head Cap Screw 1.1/2" long
38.	139X156	Fork Lever
39.	203/05L	5/16" B.S.F. Hexagon Locknut
40.	154/05	5/16" Spring Washer
41.	155/0516	5/16" B.S.F. Socket Head Cap Screw 1" long
42.	155/0620	3/8" B.S.F. Socket Head Cap Screw 1.1/4" long
43.	154/06	3/8" Spring Washer
45.	182/0516	5/16" B.S.F. Socket Set Screw Taper Point 1" long
46.	155/0624	3/8" B.S.F. Socket Head Cap Screw 1.1/2" long
47.	154/06	3/8" Spring Washer
48.	139X155	Operating Arm
49.	139Z161	3rd Station Forming Slide Base
50.	139X174	Extractable Plug
51.	101/10	External Circlip 15/16" dia.
52.	137X162	Spacer
53.	137V165/E	Micrometer Head (English)
54.	137V165/M	Micrometer Head (Metric)
55.	139Y153	Gib Strip
56.	139Y152	Forming Slide
57.	155/0620	3/8" B.S.F. Socket Head Cap Screw 1.1/4" long
58.	154/06	3/8" Spring Washer
59.	167/0520	5/16" B.S.F. Hexagon Head Set Screw 1.1/4" long
60.	141/6	13/32" Taper Pin 1.1/2" long
61.	137CY105	Connecting Link
62.	137CX120A	Scale
64.	165/406	4BA Round Head Set Screw 3/8" long

65.	137CX107	Tee Bolt Plate
66.	137CX.106	Tee Bolt Plate
67.	154/04	1/4" Spring Washer
68.	155/0420	1/4" B.S.F. Socket Head Cap Screw 1.1/4" long
69.	137CX109	Sliding Sleeve
70.	155/0416	1/4" B.S.F. Socket Head Cap Screw 1" long
71.	137CX119	Tee Bolt
72.	137CX123	Bush for Connecting Link
73.	141X116	Slotted Washer
74.	173/10HL	5/8" B.S.F. Hexagon Nut
75.	142X125A	Pad Bush
76.	142X126A	Pad Bush
77.	142X143A	Pad Bolt
78.	137X138	Spring
79.	129/7	5/8" dia. Welch Plug

SETTING INSTRUCTIONS.

- 1 SET MACHINE ON DWELL.
- 2 REMOVE PIN 137CX10B & SET ADJUSTING BLOCK 137CX109 ON $\frac{1}{4}$ " STROKE.
- 3 WITH SLIDE ADJUSTED FULLY FORWARD & SET TO $2\frac{7}{8}$ " DIMENSION SET LEVER 139X156 ON SERRATIONS. IF DIMENSION THUS OBTAINED IS GREATER THAN $2\frac{7}{8}$ ", MOVE LEVER 139X156 ONE SERRATION BACKWARD.
- 4 SET ADJUSTING BLOCK 137CX109 ON MINIMUM STROKE.
- 5 CHECK THAT SLIDE IS CLEAR OF SPINDLE COVER & THAT FIRST TEE-SLOT CAN BE ADJUSTED BACK TO $3\frac{1}{2}$ " FROM SPINDLE CENTRE.

SECTION 137C

FITTER TO MARK LINE ON 139Y157A 139X156 ON ASSEMBLY

FOR VOGEL LUBRICATION PARTS SEE 168218.
FOR TRABON LUBRICATION PARTS SEE 168271.

FITTER TO MARK LINE ON 139Y157 & 139X155 ON ASSEMBLY

ADJUST ON TOP FACE OF SLIDE 139Y152 TO OBTAIN THIS DIMENSION

$2\frac{7}{8}$ " MAX. FORWARD POSITION
 2.005
 1.995

SECTION 137C

SECTION 141

SECTION 141

SECTION 137C

Drg No.141Z1 ----- Cross Slide Operation

1.	167/0520	5/16" B.S.F. Hexagon Head Set Screw 1.1/4" long
2.	176/0405	1/4" B.S.F. Socket Head Set Screw 5/16" long
3.	141Y113B	Approach Arm - Front
4.	137CX107	Tee Bolt Plate
5.	141Z101A	Cam Lever Front Cross Slide
6.	141X107A	Lower Approach Link - Front
8.	141Y103B	Approach Anchor Link
9.	164/0406	1/4" B.S.F. Round Head Screw 3/8" long
10.	141Y150	Oil Well for Cross Slide Cams
11.	141X111	Connecting Link
12.	141Y103A	Approach Anchor Link
13.	183/0412	1/4" B.S.F. Socket Head Set Screw Taper Point 3/4" long
14.	141Z102A	Cam Lever Rear Cross Slide
15.	141Y106	Feed Link
16.	141Y105A	Lower Approach Link - Rear
17.	125/1628	1/4" dia. Taper Pin 1.3/4" long
18.	141Y104B	Approach Arm - Rear
19.	176/0405	1/4" B.S.F. Socket Head Set Screw 5/16" long
20.	141Y108A	Feed Link
21.	141X155	Support Block
22.	127/0606	Split Pin 3/32" x 3/4" long
23.	141X156	Stop Bush
24.	143/0812	Grooved Pin
25.	155/0536	5/16" B.S.F. Socket Head Cap Screw 2.1/4" long
26.	154/05	5/16" Spring Washer
27.	141X158	Stop Pin
28.	354/057	Toroidal Sealing Ring

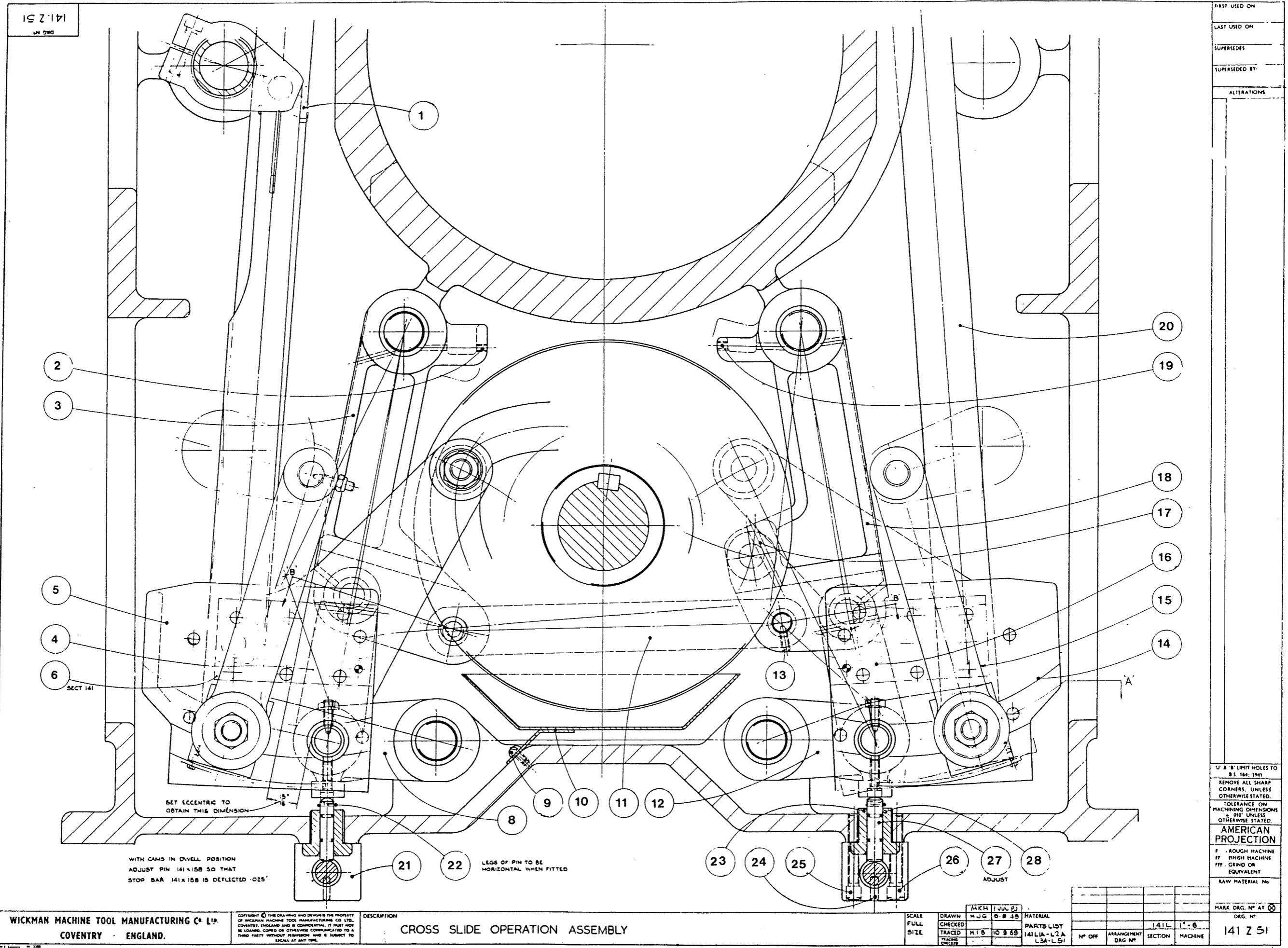

Drq No.141Z2	Cross Slide Operation
1. 236/202420	Oil Retaining Bush 1.1/4" x 1.1/2" x 1.1/4"
2. 141X134A	Adaptor
3. 141X140	Fulcrum Shaft for Approach Lever
4. 141Y108A	Feed Link
5. 137CX123	Bush for Connecting Link
6. 125/1628	1/4" Taper Pin 1.1/4" long
7. 173/10HL	5/8" Hexagon Locknut
8. 141X116	Slotted Washer
9. 173/05	5/16" B.S.F. Nut
10. 182/0516	5/16" B.S.F. Socket Head Set Screw Taper Point 1" long
12. 141X147A	English or Metric Scale for Upper Cross Slide
13. 165/406	4BA Round Head Screw 1/8" long
14. 154/05	5/16" Spring Washer
15. 155/0516	5/16" B.S.F. Socket Head Cap Screw 1" long
16. 141X157	Bridge Piece
17. 141X133	Adjusting Washer
18. 137CX108	Pin for Connecting Link
19. 141X133	Adjusting Washer
20. 137CY105	Connecting Link
21. 173/06	3/8" B.S.F. Hexagon Nut
22. 182/0620	3/8" B.S.F. Socket Head Set Screw Taper Point 1.1/4" long
23. 141X123	Pin for Cam Roller
24. 141X121	Cam Roller
25. Type T	5/8" B.S.F. Simmonds Pinnacle Nut
26. 141X112A	Connecting Pin for Lower Cross-Slide
27. 125/1624	1/4" Taper Pin 1.1/2" long
28. 141Y106A	Feed Link
29. 137CX121A	Scale
31. 165/406	4BA Round Head Screw 3/8" long
32. 155/0420	1/4" B.S.F. Socket Head Cap Screw 1.1/4" long
33. 154/04	1/4" Spring Washer
34. 155/0416	1/4" B.S.F. Socket Head Cap Screw 1" long
35. 137CX119	Tee Bolt
36. 137CX109	Sliding Sleeve
37. 141X145B	Scale for Front Lower Cross Slide
38. 168/406	4BA Hexagon Head Set Screw 3/8" long
39. 236/202420	Oil Retaining Bush 1.1/4" x 1.1/2" x 1.1/4"
40. 141X139	Fulcrum Shaft for Approach Lever
41. 173/06	3/8" B.S.F. Hexagon Nut
42. 182/0620	3/8" B.S.F. Socket Head Set Screw Taper Point 1.1/4" long
43. 141X133	Adjusting Washer
44. 141X112A	Connecting Pin (For Lower Cross slide).
45. 125/1624	1/4" dia. Taper Pin 1.1/2" long
46. 141X122	Pin for Fast Motion Cam Roller
47. 141X121	Cam Roller
48. 125/1628	1/4" dia. Taper Pin 1.3/4" long
49. 141X146B	Scale for Rear Lower Cross Slide
50. 168/406	4BA Hexagon Head Set Screw 3/8" long
51. 141X133	Adjusting Washer
52. 141X134A	Adaptor
53. Type T	5/8" B.S.F. Simmonds Pinnacle Nut
54. 141X121	Cam Roller
55. 141X123	Pin for Cam Roller

- 56. 182/0516 5/16" B.S.F. Socket Head Set Screw Taper Point
1" Long
- 57. 173/05 5/16" B.S.F. Hexagon Nut
- 58. 165/406 4BA Round Head Screw 3/8" long
- 59. 141X147A Scale for Upper Cross Slide
- 61. 141X120 Stop Screw
- 62. 188/0620 3/8" B.S.F. Square Head Set Screw 1.1/4" long
- 63. F122 3/8" B.S.F. Simmonds Elastic Stop Nut
- 64. 167/0524 5/16" B.S.F. Hexagon Head Set Screw 1.1/2" long
- 65. 154/05 5/16" Spring Washer
- 66. 141X159 Stop Shaft

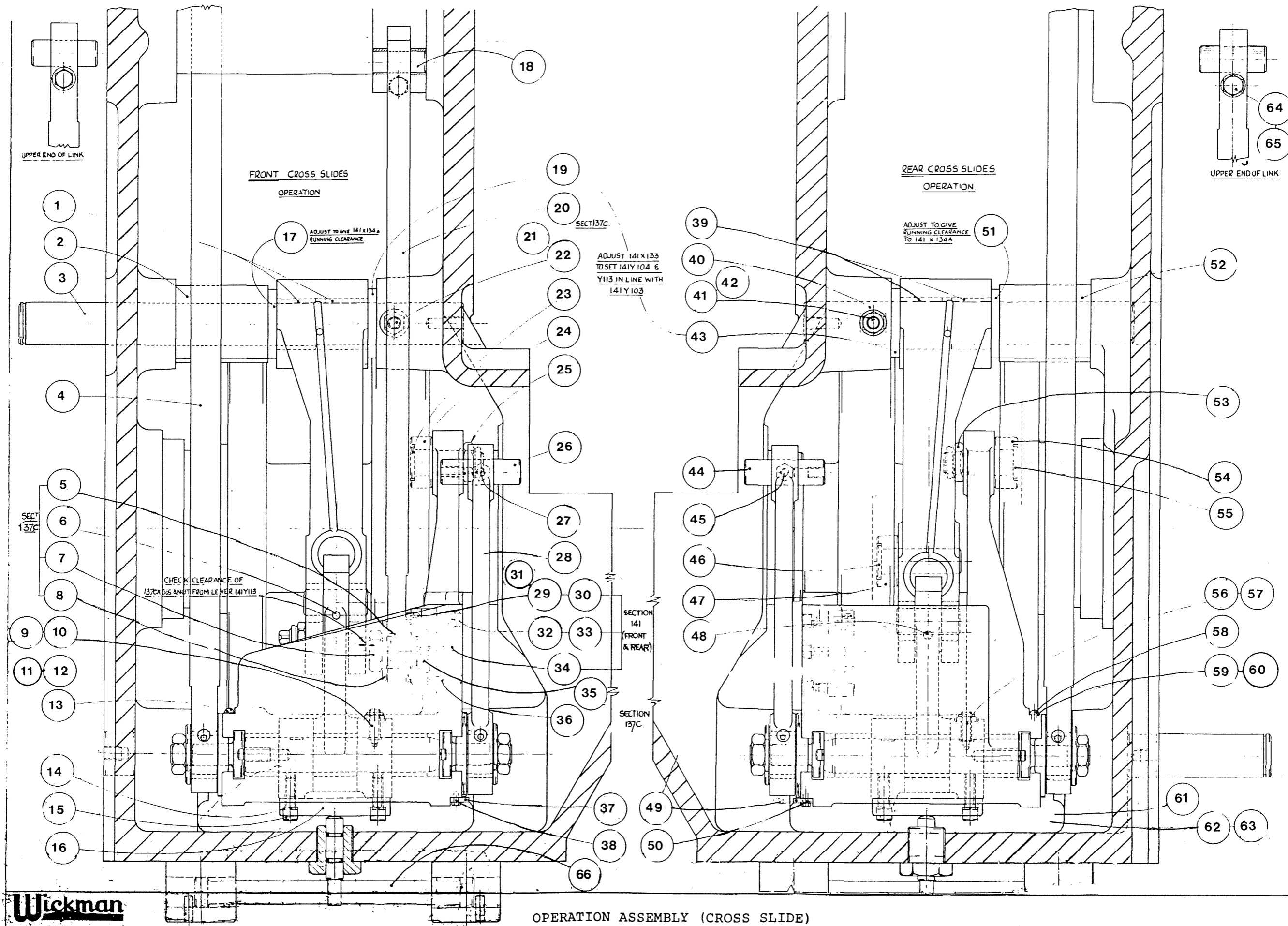

FIRST USED ON BATCH
LAST USED ON BATCH
SUPERSEDED BY
SUPPLEMENTED BY
ALTERATIONS

CHECKED R/S 18-4
 TRACED DAT
 A.T. 9 27-5-4

Wickman

OPERATION ASSEMBLY (CROSS SLIDE)

141 Z 2

1.	141X125	Pivot Bush for Approach Lever
2.	141X124	Pivot Pin
3.	236/101412	Oil Retaining Bush 5/8" x 7/8" x 3/4"
4.	141X110	Eccentric Pin
5.	Type T	1/4" B.S.F. Simmonds Pinnacle Nut
6.	141X109	Link Pin
7.	236/101412	Oil Retaining Bush 5/8" x 7/8" x 3/4"
8.	141X124	Pivot Pin for Approach Lever
9.	141X125	Pivot Bush for Approach Lever
10.	236/162016	Oil Retaining Bush 1" x 1.1/4" x 1"
11.	122X154	Extractable Plug
12.	182/0620	3/8" B.S.F. Taper Point Socket Set Screw 1.1/4" long
13.	173/06	3/8" B.S.F. Hexagon Nut
14.	141X129	Fulcrum Shaft for Anchor Link
15.	236/202432	Oil Retaining Bush 1.1/4" x 1.1/2" x 2"
16.	256/202432	Oil Retaining Bush 1.1/4" x 1.1/2" x 2"
17.	141X129	Fulcrum Shaft for Anchor Link
18.	173/06	3/8" Hexagon Nut
19.	182/0620	3/8" B.S.F. Taper Point Set Screw 1.1/4" long
20.	122X154	Retractable Plug
21.	236/162016	Oil Retaining Bush 1" x 1.1/4" x 1"
22.	173/10HL	5/8" B.S.F. Hexagon Locknut
23.	141X116	Slotted Washer
24.	B.S.68	Oilite Bush 1.1/8" x 1.3/8" x 3/4"
25.	141X141	Sliding Sleeve
26.	141X119	Tee Bolt
27.	141X127	Cam Lever Pivot
28.	236/162020	Oil Retaining Bush 1" x 1.1/4" x 1.1/4"
29.	154/2	2BA Spring Washer
30.	156/208	2BA Socket Head Cap Screw 1/2" long
31.	236/162016	Oil Retaining Bush 1" x 1.1/4" x 1"
32.	236/202432	Oil Retaining Bush 1.1/4" x 1.1/2" x 2"
33.	236/202432	Oil Retaining Bush 1.1/4" x 1.1/2" x 2"
34.	236/762016	Oil Retaining Bush 1" x 1.1/4" x 1"
35.	173/10HL	5/8" B.S.F. Hexagon Locknut
36.	141X116	Slotted Washer
37.	BS68	Oilite Bush 1.1/8" x 1.3/8" x 3/4" long
38.	141X141	Sliding Sleeve
39.	141X119	Tee Bolt
40.	236/162020	Oil Retaining Bush 1" x 1.1/4" x 1.1/4"
41.	141X127	Cam Lever Pivot
42.	154/03	3/16" Spring Washer
43.	156/208	2BA Socket Head Cap Screw 1/2" long

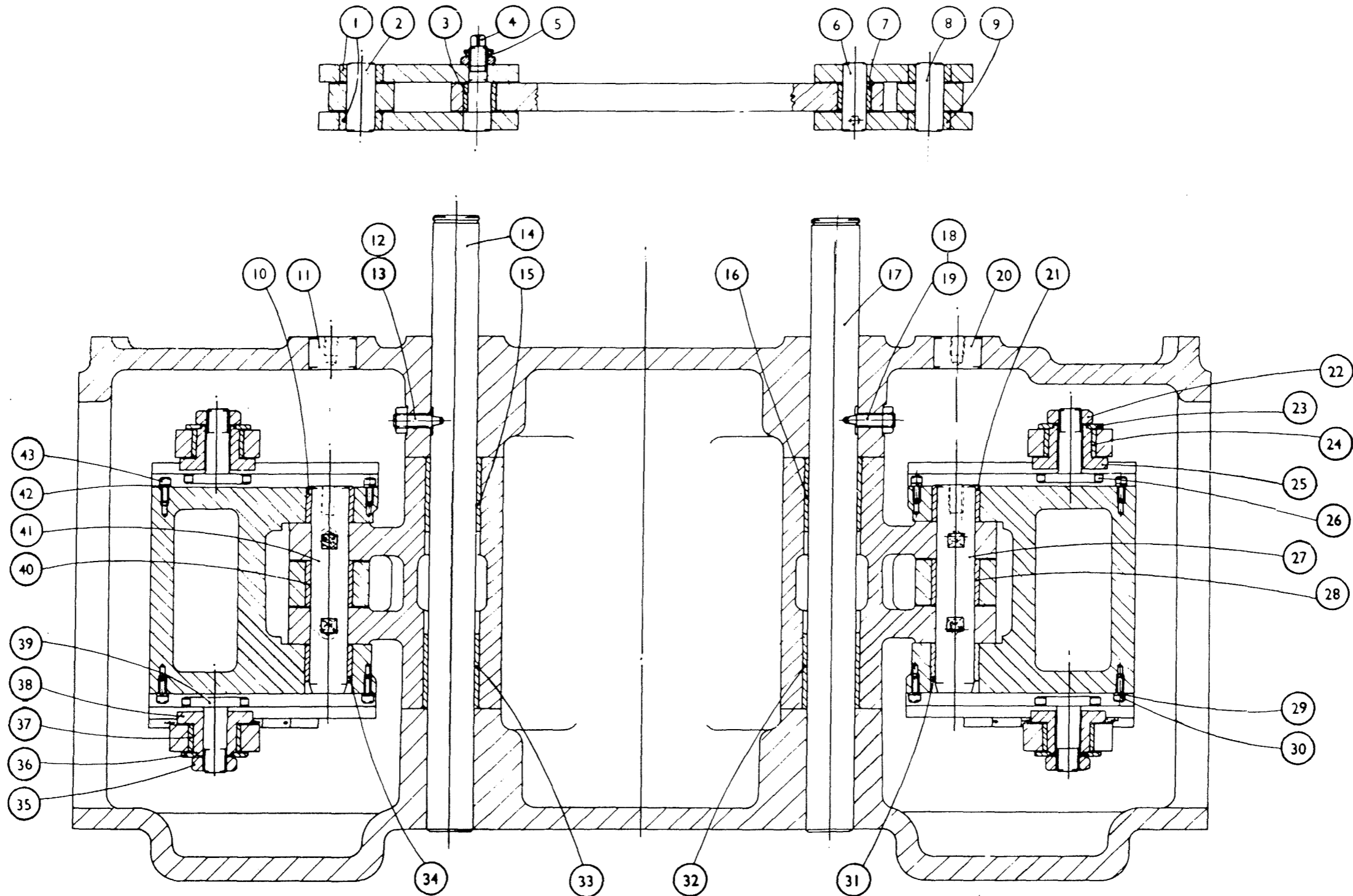

141 Z 3

141 Z 3

CROSS SLIDE OPERATION

Drq No.142Z1B Lower Cross Slides

1.	236/121612	Oil Retaining Bush 3/4" x 1" x 3/4"
2.	142X136	Feed Lever
3.	154/06	3/8" Spring Washer
4.	155/0624	3/8" B.S.F. Sockets Head Cap Screw 1.1/2" long
5.	194/1	1/8" B.S.P. Socket Pipe Plug
5a.	155/0844	1/2" B.S.F. Socket Head Cap Screw 2.1/2" long
5b.	154/08	1/2" Dia. Washer
6.	142X135A	Splined Shaft
7.	142X137A	Fork Lever
8.	142X132A	Bush
9.	101/15	External Circlip 1.1/4" dia.
12.	142V112/M	Adjusting Bolt Head (Metric)
13.	142V112/E	Adjusting Bolt Head (English)
14.	182/0612	3/8" B.S.F. Socket Set Screw 3/4" long
15.	198/6	3/16" "Shakeproof" Lockwasher
16.	156/208	2BA Socket Head Cap Screw 1/2" long
17.	142X141	Slide Base Shield
20.	141/11	7/16" Taper Pin 1.1/4" long.
21.	182/0616	3/8" B.S.F. Socket Set Screw 1" long
22.	173/06	3/8" B.S.F. Hexagon Nut
23.	142X138B	Cross Slide Nut
24.	144/05	Nylon Pad
25.	188/0512	5/16" Square Set Screw 1/4" long
26.	142X139B	Adjusting Bolt
31.	141/1128	7/16" Taper Pin 1.3/4" long
32.	142Z107C	Lower Cross Slide Base - Front
33.	142X130D	Stop Bracket - Front
34.	142Z101A	Lower Cross Slide (Front)
35.	159/206	2BA Socket Head Countersunk Screw 1/2" long
36.	142X140A	End Shield for Slide
37.	142Z102B	Lower Cross Slide (Rear)
38.	142X131D	Stop Bracket - Rear
39.	142Z108C	Lower Cross Slide Base - Rear
40.	154/03	1/2" Spring Washer
41.	155/0828	1/2" B.S.F. Socket Head Cap Screw 1.3/4" long
42.	182/0512	5/16" Socket Set Screw 3/4" long
43.	155/0864	1/2" B.S.F. Socket Head Cap Screw 4" long
44.	154/08	1/2" Spring Washer
45.	142X124D	Stop Bracket Screw
46.	142X123C	Stop Bracket Bush
48.	154/04	1/4" Spring Washer
49.	155/0410	1/4" B.S.F. Socket Head Cap Screw 5/8" long
50.	173/05H	5/16" B.S.F. Nut
51.	142X114	Gib Strip
52.	142X113	Gib Strip
53.	FX4539C	Adjusting Screw for Gib Strip
54.	182/0616	3/8" B.S.F. Socket Set Screw 1" long
55.	203/06L	3/8" B.S.F. Hexagon Nut
56.	142X125A	Pad Bush
57.	142X126A	Pad Bush
58.	142X143A	Pad Bolt
59.	176/0612	3/8" B.S.F. Set Screw x 3/4" long

142Z1B

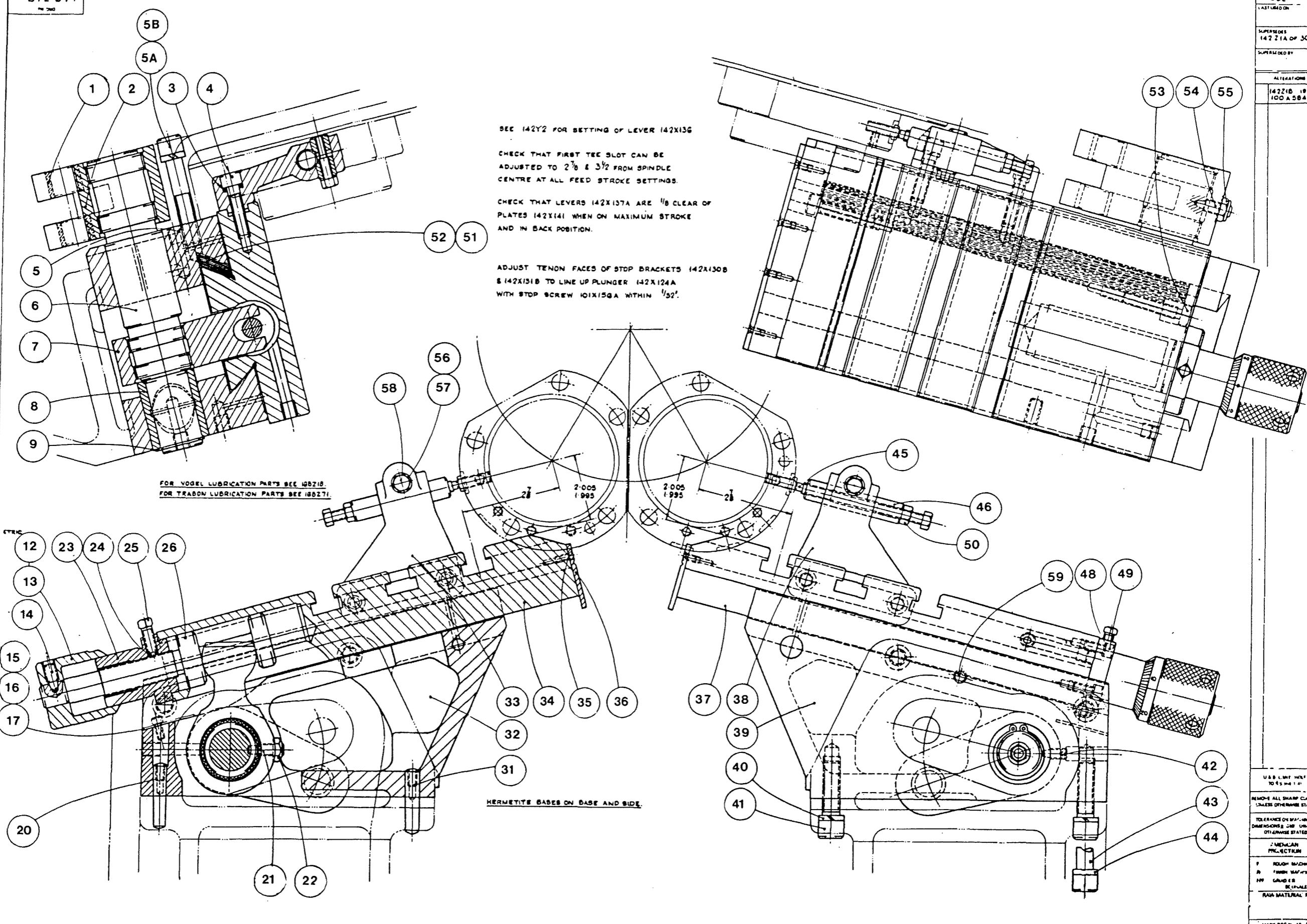

SEE 142Y2 FOR SETTING OF LEVER 142X136

CHECK THAT FIRST TEE SLOT CAN BE ADJUSTED TO 2 7/8 & 3 1/2 FROM SPINDLE CENTRE AT ALL FEED STROKE SETTINGS.

CHECK THAT LEVERS 142X137A ARE 1/8 CLEAR OF PLATES 142X141 WHEN ON MAXIMUM STROKE AND IN BACK POSITION.

ADJUST TENON FACES OF STOP BRACKETS 142X130B & 142X131B TO LINE UP PLUNGER 142X124A WITH STOP SCREW 101X150A WITHIN 1/32".

FOR VOGEL LUBRICATION PARTS SEE 142Z18
FOR TRABON LUBRICATION PARTS SEE 142Z71

HERMETITE BASES ON BASE AND SIDE.

WICKMAN MACHINE TOOL MANUFACTURING CO. LTD.
COVENTRY - ENGLAND.

LOWER CROSS SLIDES

REVISED BY	1032
DATE	
APPROVED BY	
DATE	
REVISIONS	
NO.	142 Z 1 A OF 30-9-45
DATE	
BY	
REASON	
142Z1B ISSUED	
100 A 584	

U.S. UNIT UNITS	TO 45 AND 141
REMOVE ALL SHARP EDGES	UNLESS OTHERWISE STATED
TELERANCE ON MAT-UR	DIMENSIONS IS UNLESS OTHERWISE STATED
Z-MERLAIN	PROLECTUM
F	ROUGH SURFACE
R	FRESH SURFACE
FF	GRINDERS
RA	EQUIVALENT
RAW MATERIAL	PL.

142 Z 1 B

Drq No.144Z1D ----- Main Camshaft

1.	154/05	Spring Washer 5/16" dia.
2.	154/05	Spring Washer 5/16" dia.
3.	154/06	Spring Washer 3/8" dia.
4.	155/0516	Hol. Hex. Cap Screw 5/16" BSF 1" long
5.	155/0524	Hol. Hex. Cap Screw 5/16" BSF 1.1/2" long
6.	155/0620	Hol. Hex. Cap Screw 3/8" BSF 1.1/4" long
7.	144X128	Bearing Clamp
8.	212/04	Grease Nipple Autolub 1/4 BSF
9.	157Y115A	Collet Operating Cam
10.	155/0716	Hol. Hex. Cap Screw 7/16" BSF 1" long
11.	144X147A	Camshaft Key
12.	154/05	Spring Washer 5/16" dia.
13.	155/0512	Hol. Hex. Cap Screw 5/16" BSF x 3/4" long
14.	156/208	Hol. Hex. Cap Screw 2BA 1/2" long
15.	154/03	Spring Washer 3/16" dia.
16.	155/0716	Hol. Hex. Cap Screw 7/16" BSF 1" long
17.	144Y117B	Collet Operating Cam
18.	144Y122A	Outer Clutch Ring
19.	144Y156	Bar Feed Cam
20.	155/0716	Hol. Hex. Cap Screw 7/16" BSF 1" long
21.	212/04	Grease Nipple Autolub 1/4" BSF
22.	210/1725	Indicator Washer
23.	144X144A	5/8" dia. Dowel
24.	155/0508	Hol. Hex. Cap Screw 5/16" BSF x 1/2" long
25.	125/1614	Taper Pin 1/4" dia. 7/8" long
26.	4X115A	Bar Stop Cam
27.	144V530	Body for Bar Stop Cams
28.	176/0510	Hol. Hex. Set Screw 5/16" BSF x 5/8" long
29.	144X134	Camshaft Bush, Drum H'sg.
30.	144X137	Camshaft Brg. Sleeve (REAR)
31.	144Z104A	Rear Cross Slide Feed Cam
32.	155/0512	Hol. Hex. Cap Screws 5/16" BSF 3/4" long
33.	144X133A	Camshaft Key
34.	144Z105	Front Cross Slide Feed Cam
35.	144V135A	Camshaft Bush Drum H'sg.
36.	155/0406	Socket Cap Screw 1/4" BSF x 3/8" long
37.	212/18	Grease Nipple Autolub 1/8" BSF
38.	210/2525	Indicator Washer
39.	144V120A	Bearing Cap
40.	144X121A	Bearing Housing
41.	263/50	Ball Journal Angular Contact. Metric, Light 50mm
42.	144X145B	Thrust Ring
43.	244X129A	Clutch Spring
44.	244X146	Spring Support
45.	144Y123A	Clutch Body
46.	144X127A	Thrust Ring
47.	155/0824	Hol. Hex. Cap Screw 1/2" BSF 1.1/2" long
48.	154/08	Spring Washer 1/2" dia.
49.	144X144A	5/8" dia. Dowel
50.	125/3264	1/2" dia. Taper Pin x 4" long
51.	144Z102A	Cam Drum
52.	155/0716	Hol. Hex. Cap Screw 7/16" BSF 1" long
53.	144Y109A	Collet Operating Cam
54.	155/0716	Hol. Hex. Cap Screw 7/16" BSF 1" long
55.	144Y108A	Collet Operating Cam
56.	144Y109A	Collet Operating Cam
57.	155/0716	Hol. Hex. Cap Screw 7/16" BSF 1" long

58.	144Y108A	Collet Operating Cam
59.	155/0716	Hol. Hex. Cap Screw 7/16" BSF 1" long
60.	155/0716	Hol. Hex. Cap Screw 7/16" BSF 1" long
61.	144Y155	Bar Feed Cam
62.	154/08	Spring Washer 1/2" dia.
63.	155/0824	Hol. Hex. Cap Screw 1/2" BSF x 1.1/2" long
64.	144Y531A	Geneva Arm and Drum Locking Cam
65.	144X149A	Roller Pin
66.	182/0624	Socket Set Screw Taper Point 3/8" BSF x 1.1/2" long
67.	203/06	Hex. Nut Self Locking 3/8" BSF
68.	123X104	Roller
69.	144Z101C	Main Camshaft
70.	155/0512	Hol. Hex. Cap Screw 5/16" BSF 3/4" long
71.	144X150	Camshaft Key
72.	158/0412	Socket Countersunk Screw 1/4" BSF 3/4" long
73.	144X112	Cam Insert
74.	154/05	Spring Washer 5/16" dia.
75.	155/0510	Hex. Cap Screw 1/2" BSF x 5/8" long
76.	154/08	Spring Washer 1/2" dia.
77.	155/0828	1/2" BSF Cap Screw x 1.3/4" long
78.	118Y124A	Lower Wormwheel
79.	144X112	Cam Insert
80.	154/05	Spring Washer 5/16" dia.
81.	155/0516	Hol. Hex. Cap Screw 5/16" BSF 1" long
82.	144X138	Camshaft Bearing Sleeve (FRONT)
83.	155/0536	Hol. Hex/ Cap Screw 5/16" BSF 2.1/4" long
84.	154/05	Spring Washer 5/16" dia.
85.	144V152	Camshaft Housing
86.	144X154	End Cap
87.	154/05	Spring Washer 5/16" dia.
88.	155/0516	Hol. Hex. Cap Screw 5/16" BSF 1" long
89.	101X281	Piston Ring
90.	144X153	Ring Housing
91.	354/38	'O' Ring for 2.3/4" dia.
92.	155/0412	Hol. Hex. Cap Screw 1/4" BSF 3/4" long
93.	154/04	Spring Washer 1/4" dia.
94.	144X132A	Camshaft Bearing
95.	144Y130C	3rd Position Cam Drum
96.	144X139	Cam Thrust Ring
97.	118Y118D	Wormwheel Hub
98.	141/14	1/2" dia. Taper Pin 2" long
99.	118X123A	Thrust Washer
100.	236/404848	Oil Retaining Bush 2.1/2" dia. x 3" x 3"

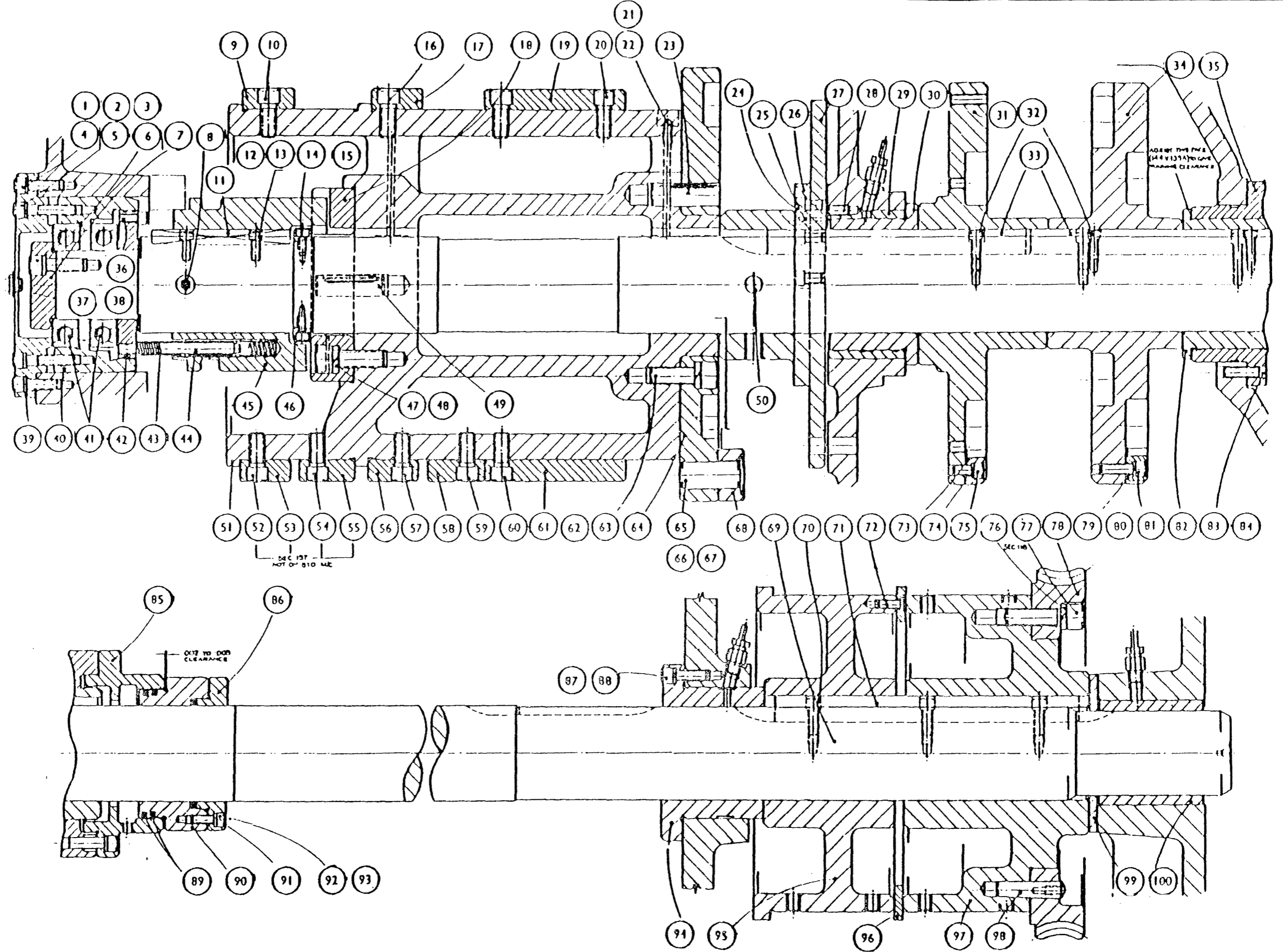

Drg No.145Z1A Index Clutch Operation

- | | | |
|-----|----------|--|
| 1. | 145X109 | Plunger Handle. |
| 2. | 125/1216 | 3/16" Taper Pin 1" long |
| 3. | 125/1220 | 3/16" Taper Pin 1.1/4" long |
| 4. | 145X107 | Bush |
| 5. | 145X110 | Plunger String |
| 6. | 145X108 | Plunger |
| 7. | 155/0520 | 5/16" B.S.F. Socket Head Cap Screw 1.1/4" long |
| 8. | 154/05 | 5/16" Spring Washer |
| 9. | 145Y105A | Clutch Lever Bracket |
| 10. | 145X104A | Pivot |
| 11. | 145Y106A | Clutch Lever |
| 12. | 101/6 | External Circlip 3/4" dia. |
| 13. | 126/1622 | 1/2" dia. Parallel Dowel Pin 1.3/8" long |
| 14. | 145X111 | Latch |
| 15. | 145X112 | Fulcrum Pin |

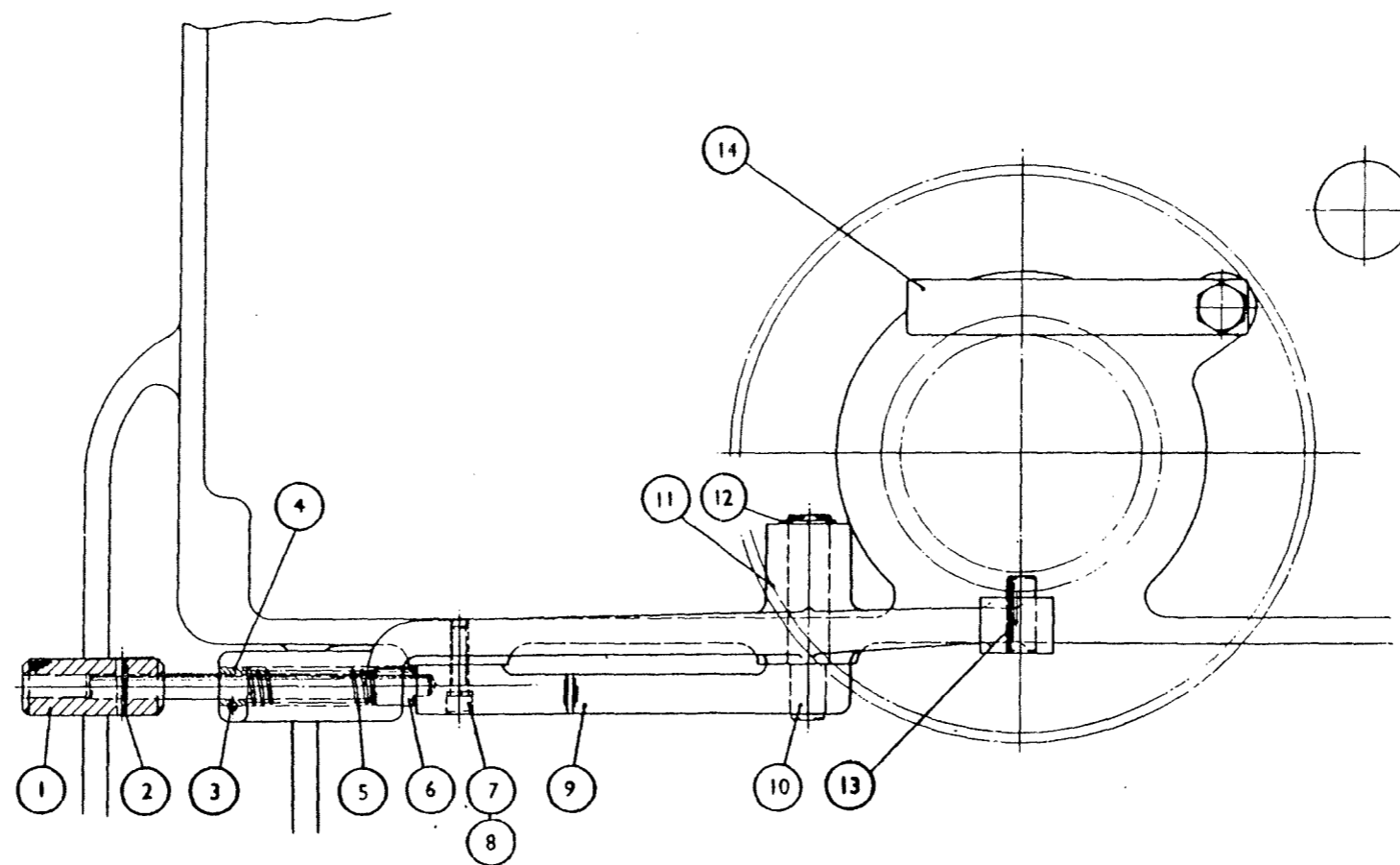
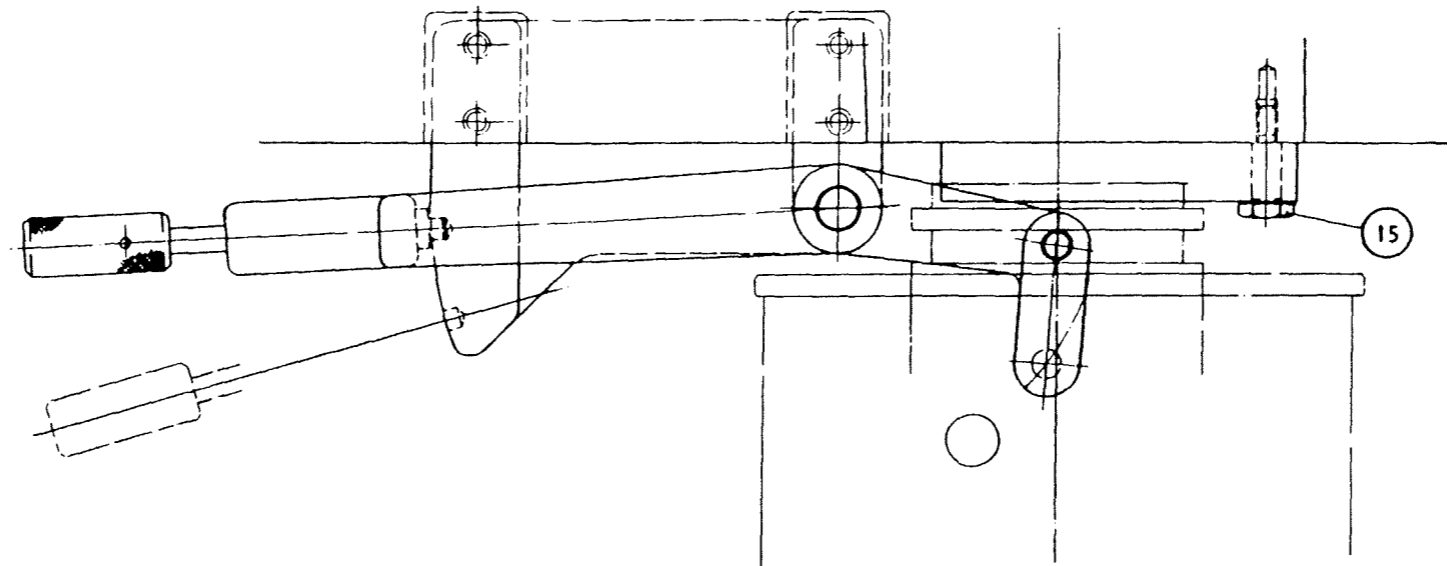

Drg No.145Y2 ----- Cam Drum Detent

- 1. 145X113 Interlock
- 2. 188/0536 5/16" B.S.F. Square Head Set Screw 2.1/4" long
- 3. 173/05L 5/16" B.S.F. Locknut
- 4. 101/15 External Circlip 1.1/4" dia.
- 5. 173/10L 5/8" B.S.F. Locknut
- 6. 150X123A Spring Anchor
- 7. 150X122A Spring
- 8. 150X125 Spring Anchor

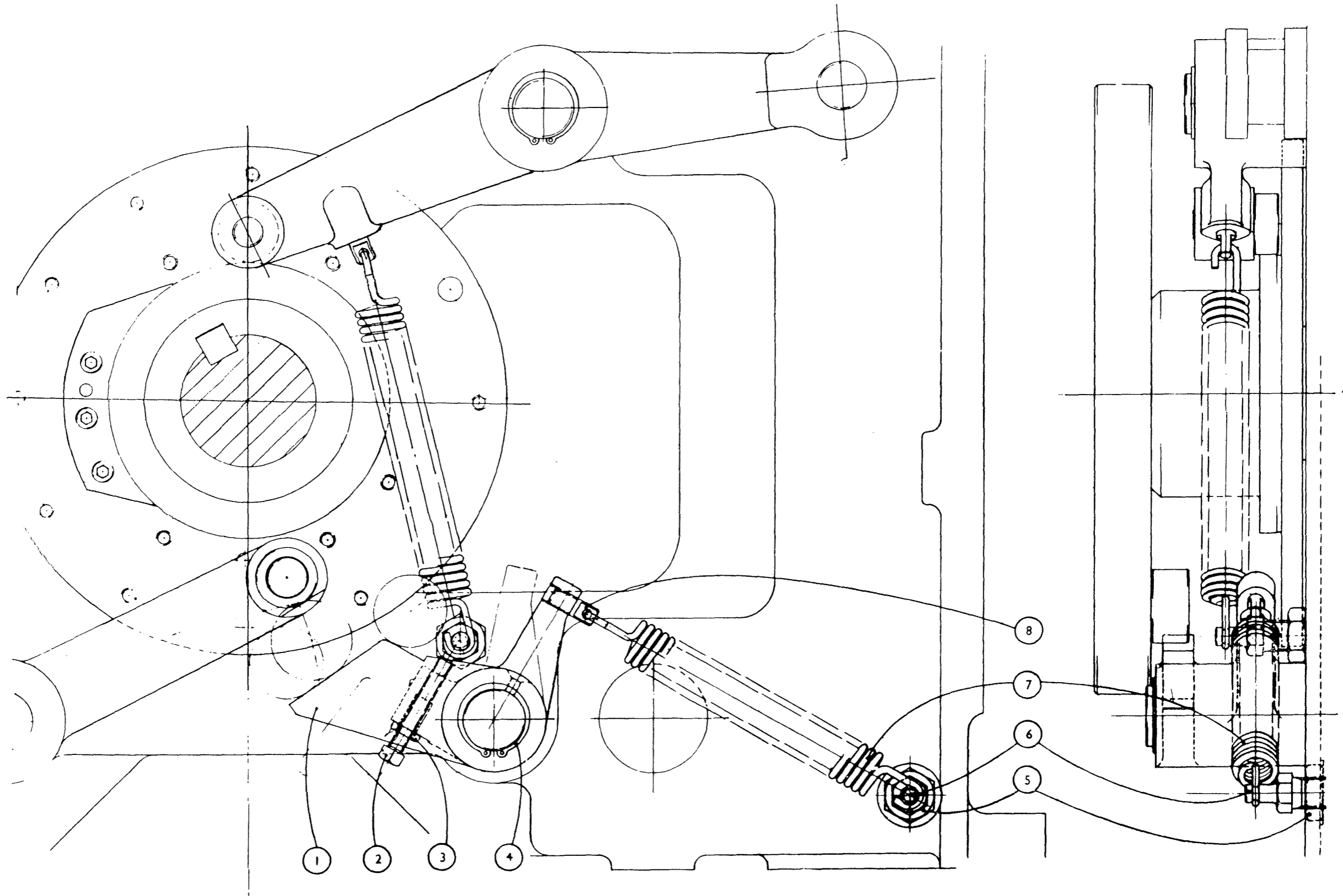

Drg No.146Z1 ----- Indexing Gears

- 1. 146Y102 Geneva Wheel Gear
- 2. 146Y508 Geneva Wheel
- 3. 125/2628 Taper Pin 13/32" dia. x 1.3/4" Long
- 4. 155/0724 7/16" B.S.F Socket Head Cap Screw 1.1/2" Long
- 5. 155/0514 5/16" B.S.F Socket Head Cap Screw 7/8" Long
- 6. 146X103 Geneva Wheel Bearing
- 7. 155/0514 5/16" B.S.F Socket Head Cap Screw 7/8" Long
- 8. 146X107B Spigot
- 9. 176/0404 1/4" B.S.F Set Screw 1/4" Long
- 10. 146V104C Pivot for Geneva Wheel
- 11. 155/0724 7/16" B.S.F Socket Head Cap Screw 1.1/2" Long

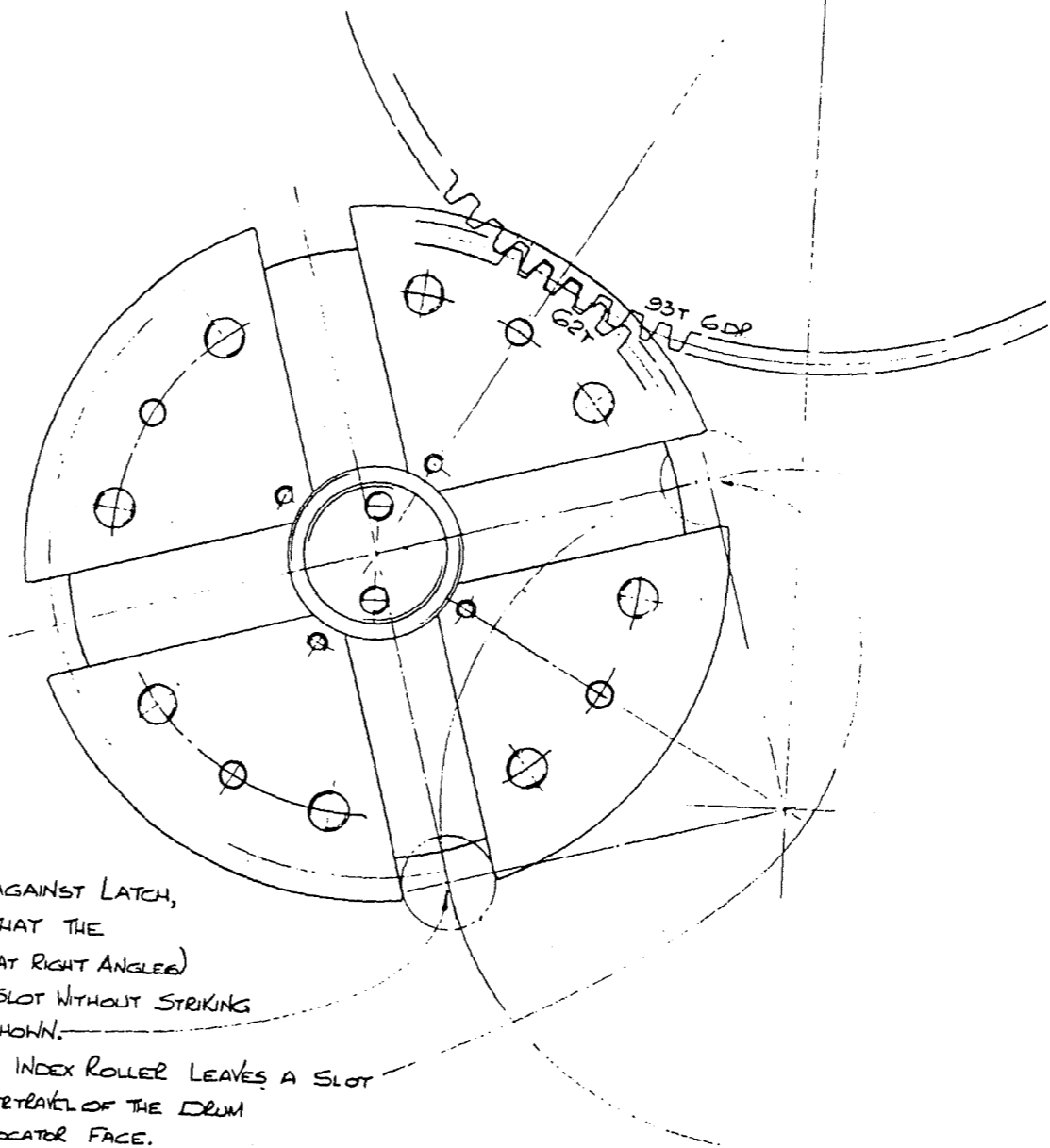
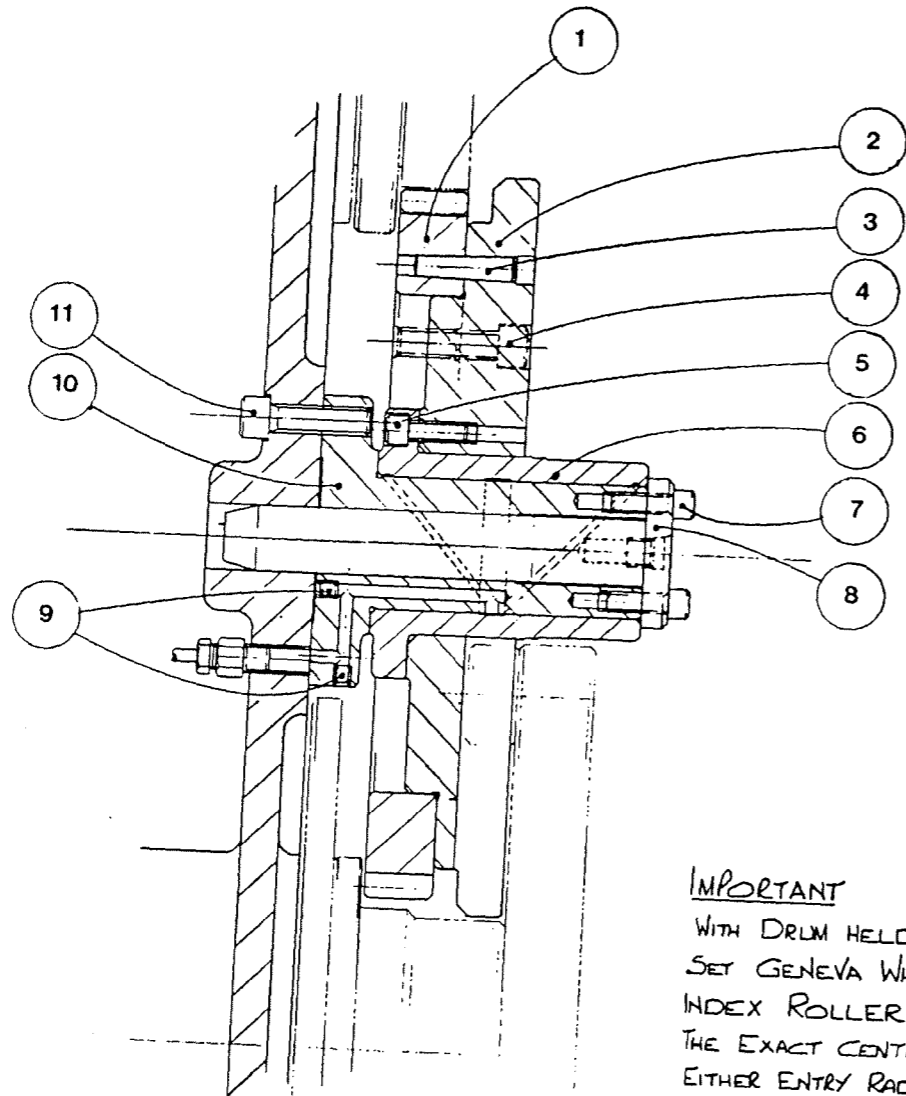

IMPORTANT
 WITH DRUM HELD FIRMLY AGAINST LATCH,
 SET GENEVA WHEEL SO THAT THE
 INDEX ROLLER ENTERS (AT RIGHT ANGLES)
 THE EXACT CENTRE OF A SLOT WITHOUT STRIKING
 EITHER ENTRY RADIUS, AS SHOWN.
 OVERTRAVEL OF GENEVA WHEN INDEX ROLLER LEAVES A SLOT
 RESULTS IN 0.25" NOMINAL OVERTRAVEL OF THE DRUM
 MEASURED BETWEEN LATCH & LOCATOR FACE.

WICKMAN AUTOMATIC LATHES LTD. COVENTRY ENGLAND.		<small>COPYRIGHT © THIS DRAWING AND DESIGN IS THE PROPERTY OF WICKMAN AUTOMATIC LATHES LTD., COVENTRY, ENGLAND AND IS CONFIDENTIAL. IT MUST NOT BE LOANED, COPIED OR OTHERWISE COMMUNICATED TO A THIRD PARTY WITHOUT PERMISSION AND IS SUBJECT TO RECALL AT ANY TIME.</small>	DESCRIPTION INDEXING GEARS ASSEMBLY.	SCALE FULL SIZE	DRAWN CHECKED TRACED TYPED CHECKED	DATE 14/01/81	MATERIAL LCP 146L1.51	PART NO. 146L 39-6	QUANTITY 1	ARRANGEMENT DRG. No.	SECTION MACHINE	MAKE ONE SET AT © DRG. No. 146Z1
---	--	---	--	--------------------	--	------------------	--------------------------	-----------------------	---------------	-------------------------	--------------------	---

FIRST USED ON
LAST USED ON
SUPERSEDES
SUPERSEDED BY
ALTERATIONS

V & T' LIMIT HOLES TO B.S. 104 : 1941
 REMOVE ALL SHARP CORNERS UNLESS OTHERWISE STATED
 TOLERANCE ON DIMENSIONS UNLESS OTHERWISE STATED:
 DIMENSIONS < 0.10" UNLESS OTHERWISE STATED.
 AMERICAN PROJECTION
 P = ROUGH MACHINE
 PF = FINISH MACHINE
 PTF = BRASS OR EQUIVALENT
 RAW MATERIAL IN.

Drg No.150Z1A Bar Stop Operation - Front

1.	150X130	Cam Roller
2.	150X129	Cam Roller Pin
3.	125/1624	1/4" dia. Taper Pin 1.1/2" long
4.	236/202416	Oil Retaining Bush 1.1/4" x 1.1/2" x 1" long
5.	141X140	Fulcrum Shaft for Approach Lever
6.	150X120	Link Pin
7.	173/04	1/4" B.S.F. Hexagon Nut
8.	176/0410	1/4" B.S.F. Socket Set Screw Cup Point 5/8" long
9.	161X121A	Rod End
10.	144X115A	Bar Stop Cam
11.	144Y125A	Body for Bar Stop Cams
12.	150X125	Spring Anchor
13.	101/15	External Circlip 1.1/4" dia.
14.	150Y104B	Bar Stop Cam Lever
15.	150X122B	Bar Stop Cam Lever Spring
16.	173/10	5/8" B.S.F. Hexagon Nut
17.	150X123A	Spring Anchor
18.	173/08	1/2" B.S.F. Hexagon Nut
19.	150X141	Spring Retainer
20.	150X140	Spring Guide
21.	150X106A	Bar Stop Spring
22.	150X117A	Pivot Pin
23.	150X124	Adjusting Nut
24.	173/08L	1/2" B.S.F. Hexagon Locknut
25.	150X116A	Bar Stop Operating Rod
26.	182/0516	5/16" B.S.F. Socket Set Screw Taper Point 1" long
27.	173/05	5/16" B.S.F. Hexagon Nut
28.	150Y115A	Bar Stop Lever
29.	150Y112	Bar Stop Shaft
30.	188/0524	5/16" B.S.F. Square Head Set Screw 1.1/2" long
31.	173/05	5/16" B.S.F. Hexagon Nut
32.	150X142	Stop Peg

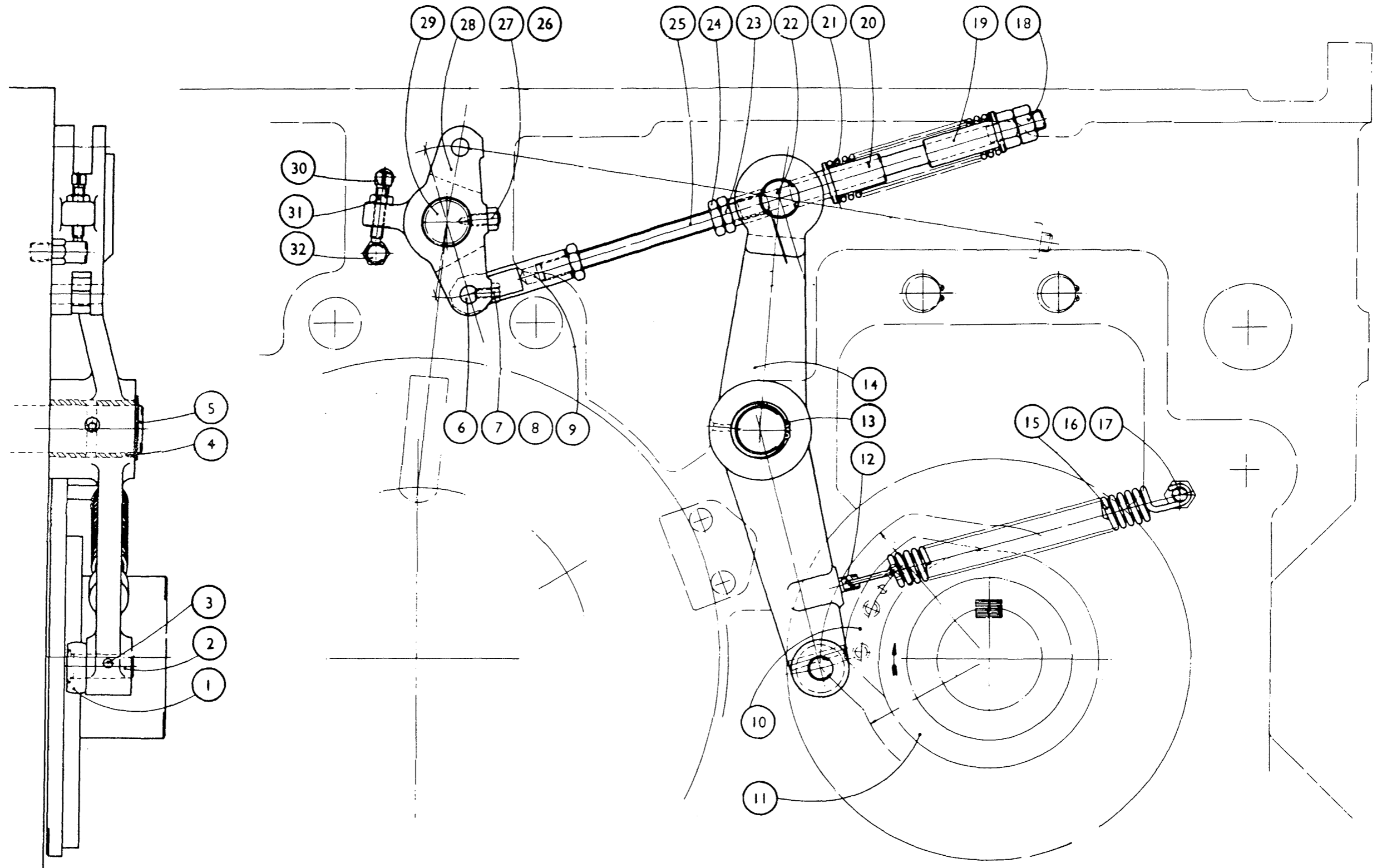

<u>Drg No.</u>	<u>150Z2A</u>	<u>Bar Stop</u>
1.	150X109B	Bar Stop
2.	155/0720	7/16" B.S.F. Socket Head Cap Screw 1.1/4" long
3.	154/07	7/16" B.S.F. Spring Washer
4.	150Y108C	Bar Stop Arm
5.	150X107	Key for Bar Stop Arm
6.	156/206	2BA Socket Head Cap Screw 3/8" long
7.	150Y112A	Bar Stop Shaft
8.	102/23	Internal Circlip 2.1/8" dia.
9.	150X113A	Thrust Spacer
10.	150X114A	Bush for Bar Stop Shaft.
11.	155/0512	5/16" B.S.F. Socket Head Cap Screw 3/4" long
12.	154/05	5/16" Spring Washer
13.	173/08L	1/2" B.S.F. Hexagon Locknut
14.	150X111	Pad Bush for Lockbolt
15.	150X110	Pad Bush for Lockbolt
16.	173/08H	1/2" B.S.F. Hardened Hexagon Nut
17.	150X132	Bar Stop Arm Hand Lever
18.	241/9/MS/P	1.1/4" Black Bakelite Knob

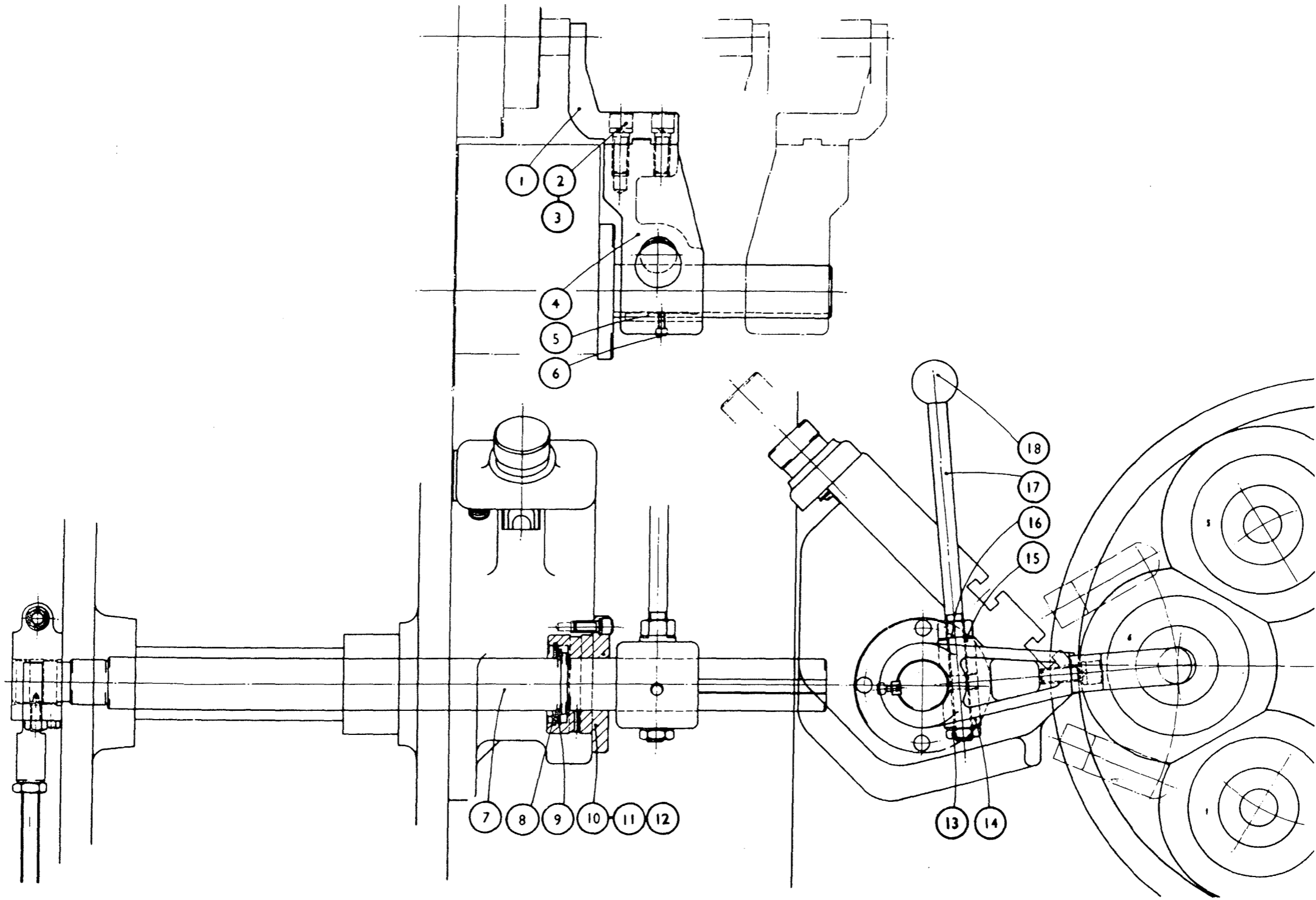

Drg No.151Z1A Rear Bar Stop

1.	150X109B	Bar Stop
2.	155/0720	7/16" B.S.F. Socket Head Cap Screw 1.1/4" long
3.	154/07	7/16" B.S.F. Spring Washer
4.	150Y108B	Bar Stop Arm
5.	154/05	5/16" Spring Washer
6.	155/0512	5/16" B.S.F. Socket Head Cap Screw 3/4" long
7.	156/206	2BA Socket Head Cap Screw 3/8" long
8.	150X107	Key for Bar Stop Arm
9.	150X114A	Bush for Bar Stop Shaft
10.	210/1725	1/4" Yellow Indicating Washer
11.	212/04	1/4" B.S.F. Autolub Nipple
12.	150X113A	Thrust Spacer
13.	102/23	Internal Circlip 2.1/8" dia.
14.	151V112B	Rear Bar Stop Shaft
15.	241/9	1.1/4" dia. Black Bakelite Knob
16.	150X132	Bar Stop Arm Hand Lever
17.	173/08H	1/2" B.S.F. Hexagon Nut
18.	150X110	Pad Bush for Lock Bolt
19.	101/4	Internal Circlip 5/8" dia.
20.	151X117	Spring Tube Pin
21.	150X111	Pad Bush for Lock Bolt
22.	173/08L	1/2" B.S.F. Hexagon Locknut
23.	150X142	Stop Peg
24.	139X122	Bearing for Operating Shaft
25.	173/05	5/16" B.S.F. Hexagon Nut
26.	151V131B	Bar Stop Lever
27.	188/0524	5/16" B.S.F. Square Head Set Screw 1.1/2" long
28.	182/0616	3/8" B.S.F. Socket Head Set Screw Taper Point 1" long
29.	182/0516	5/16" B.S.F. Socket Head Set Screw Taper Point 1" long
30.	173/05	5/16" B.S.F. Hexagon Nut
31.	173/08L	1/2" B.S.F. Hexagon Locknut
32.	173/08	1/2" B.S.F. Hexagon Nut
33.	150X106A	Bar Stop Spring
34.	151X128	Spring Tube
35.	150X130	Cam Roller
36.	150X129	Cam Roller Pin
37.	151X116	Spring Tube Link
38.	150X141	Spring Retainer
39.	125/0612	3/32" dia. Taper Pin 3/4" long
40.	173/08	1/2" B.S.F. Hexagon Nut
41.	151X117	Spring Tube Pin
42.	151Y104B	Bar Stop Cam Lever
43.	155/0520	5/16" Socket Head Cap Screw 1.1/4" long
44.	154/05	5/16" Spring Washer
45.	155/0544	5/16" B.S.F. Socket Head Cap Screw 2.3/4" long
46.	154/05	5/16" Spring Washer
47.	173/10	5/8" B.S.F. Hexagon Nut
48.	150X123A	Spring Anchor
49.	125/1624	1/4" dia. Taper Pin 1.1/2" long
50.	151X124	Spring Retainer
51.	151X122A	Rear Bar Stop Spring
52.	150X125	Spring Anchor
53.	151X135A	Rear Bar Stop Cam
54.	155/0510	5/16" B.S.F. Socket Head Cap Screw 5/8" long

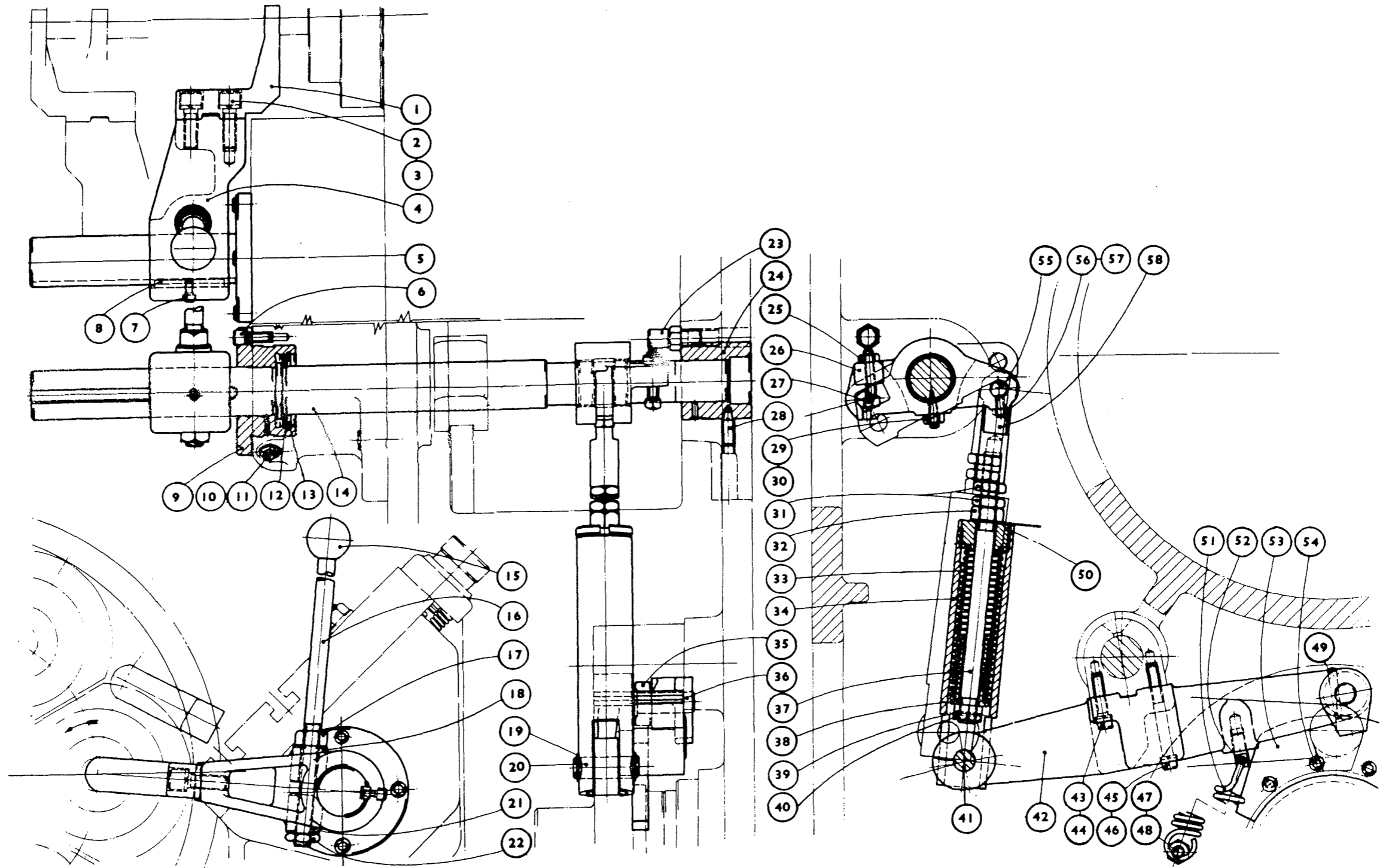

151 Z 1A BAR STOP REAR

Drg No.153Z1B Automatic Stop - Front

1.	BZE7-2RN-B	Honeywell Limit Switch
2.		4BA Washer
3.	168/424	4BA Hexagon Head Set Screw 1.1/2" long
4.	153Z120B	Aligning Disc Carrier
6.	153X149	Pin
7.	173/06L	3/8" B.S.F. Hexagon Locknut
8.	173/06	3/8" B.S.F. Hexagon Nut
9.	M.S.C.175	Morris Spring
10.	173/06	3/8" B.S.F. Hexagon Nut
11.	173/06L	3/8" Hexagon Locknut
12.	153X134	Spring Rod
13.	173/06L	3/8" B.S.F. Hexagon Locknut
14.	173/06	3/8" B.S.F. Hexagon Nut
15.	M.S.C.180	Morris Spring
16.	130/06	5/8" Washer
17.	153Y128A	Cover
18.	155/0416	1/4" B.S.F. Socket Head Cap Screw 1" long
19.	154/04	1/4" Spring Washer
20.	153X165	Stop Screw
21.	153Y122	Trip Bracket
22.	155/0536	5/16" B.S.F. Socket Head Cap Screw 2.1/4" long
23.	141/3	11/32" Taper Dowel 1.1/4" long
24.	154/05	5/16" Spring Washer
25.	210/2525	11/16" Yellow Indicating Washer
26.	212/18	1/8" B.S.P. Autolub Nipple
27.	182/0512	5/16" Socket Set Screw 3/4" long
28.	125/2228	11/32" Taper Pin 1.3/4" long
29.	153X123	Trip Lever
30.	121/0832T	Key
31.	153X124A	Spring Lever
32.	101/20	External Circlip 1.3/4" dia.
33.	153X141	Trip Shaft
34.	153X143	Roller Pin
35.	153X142	Cam Roller
36.	125/1016	5/32" Taper Pin 1" long
37.	153X129A	Cam Roller bracket
38.	153X133	Retaining Ring
39.	125/1624	1/4" Taper Pin 1.1/2" long
40.	153X153	Peg
41.	153X144B	Aligning Disc
42.	145/108	1/4" Compression Spring 2" long
43.	153X164	Plunger
44.	128/60	13/16" Pad Bush 1" long
45.	128/6T	13/16" Pad Bush 1" long
46.	173/06L	3/8" B.S.F. Hexagon Locknut
47.	153X138A	Pivot Screw
48.	153X163A	Stop Screw
49.	155/0636	3/8" B.S.F. Socket Head Cap Screw 2.1/4" long
50.	203/06L	3/8" B.S.F. Hexagon Locknut
51.	182/0620	3/8" B.S.F. Socket Set Screw 1.1/4" long
52.	153X140A	Lower Guide Bar
53.	153X137	Spring Rod
54.	173/06	3/8" B.S.F. Hexagon Nut
55.	156/408	4BA Socket Head Cap Screw 1/2" long
56.	121/0812T	Key
57.	153V121B	Pusher Bracket
58.	153X146B	Pusher Plate
59.	154/04	1/4" Spring Washer
60.	155/0410	2/4" B.S.F. Socket Head Cap Screw 5/8" long

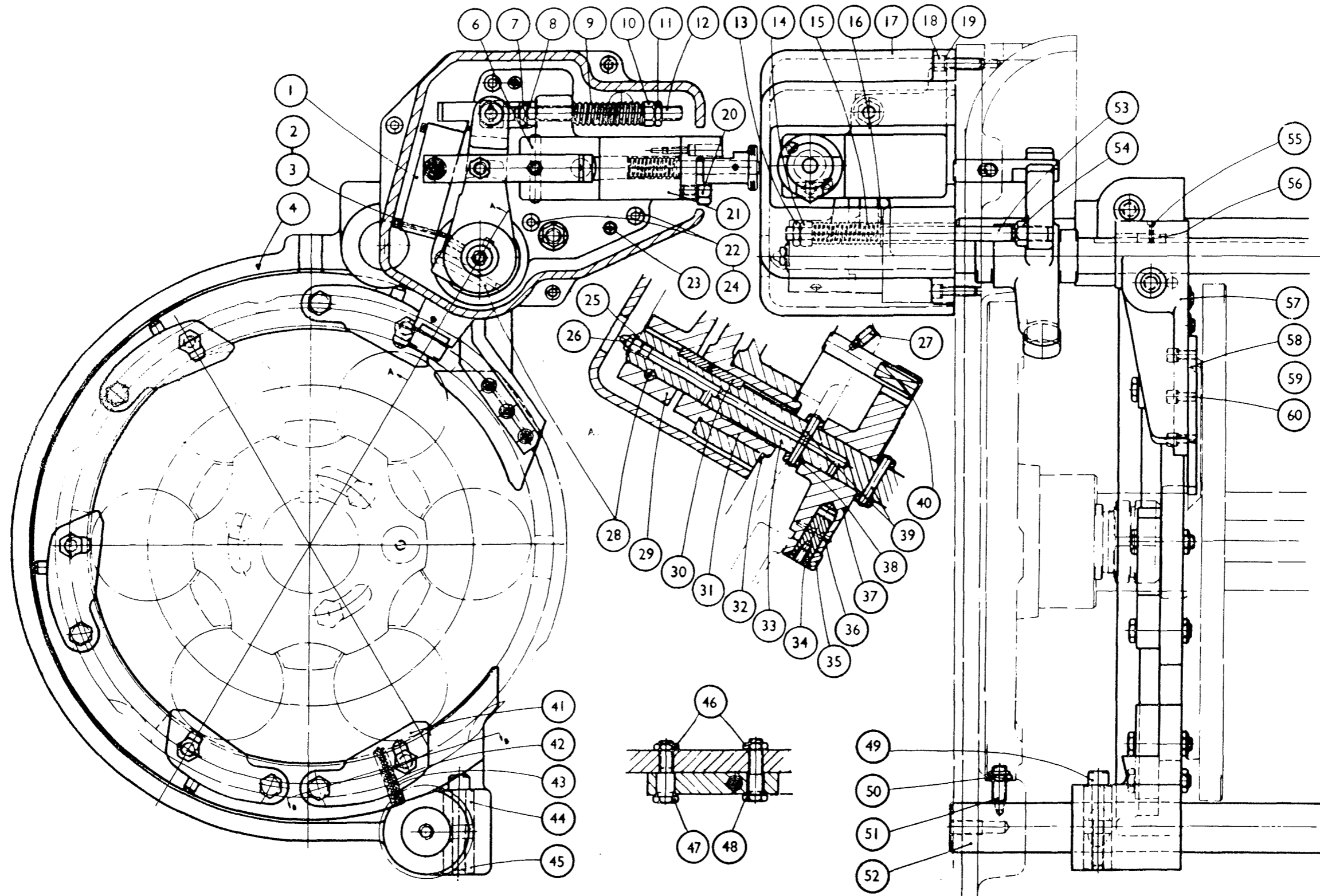

153 Z 1B AUTOMATIC STOP FRONT

Drg No.153Z2B

Automatic Stop - Front

1.	130/05	5/16" Washer
2.	203/07	7/16" B.S.F. Hexagon Locknut
3.	167/0728	7/16" B.S.F. Hexagon Head Set Screw 1.3/4" long
6.	154/05	5/16" Spring Washer
7.	155/0516	5/16" Socket Head Cap Screw 1" long
8.	203/06L	3/8" Hexagon Locknut
9.	182/0620	3/8" Socket Set Screw 1.1/4" long
10.	127/0405	1/16" Cotter Pin 5/8" long
11.	120X112	Striker Pin
12.	153X166	Trip Screw
13.	102/05L	5/16" Hexagon Locknut
14.	153X147A	Trip Lever
15.	203/04L	1/4" Hexagon Locknut
16.	176/0410	1/4" B.S.F. Socket Set Screw Cup Point 5/8" long
17.	145/146	7/16" x 2.1/2" Compression Spring
18.	158X124A	Plunger
19.	153X148	Trip Plunger
20.	153X152	Latch Spring
21.	153X135B	Latch Disc
22.	156/210	2BA Socket Head Cap Screw 5/8" long
23.	154/03	3/16" Spring Washer
24.	125/0814	1/8" Taper Pin 7/8" long
25.	153X136B	Latch Knot
26.	141/4	11/32" Taper Dowel 1.3/4" long
27.	155/0632	3/8" Socket Head Cap Screw 2" long
28.	128/6C	13/16" Pad Bush 1" long
29.	128/6T	13/16" Pad Bush 1" long
30.	128/6T	13/16" Pad Bush 1" long
31.	128/6C	13/16" Pad Bush 1" long
32.	155/0636	3/8" Socket Head Cap Screw 2.1/4" long
33.	143/1020D	5/16" Grooved Pin 1.1/4" long
34.	153X139	Upper Guide Bar
35.	153X132	Support Arm
36.	203/05L	5/16" Hexagon Locknut
37.	182/0512	5/16" Socket Head Set Screw 3/4" long
38.	153X167	Stop
39.	156/206	2BA Socket Head Cap Screw
40.	130/03	3/16" dia. Washer
41.	198/6	2BA Lock Washer

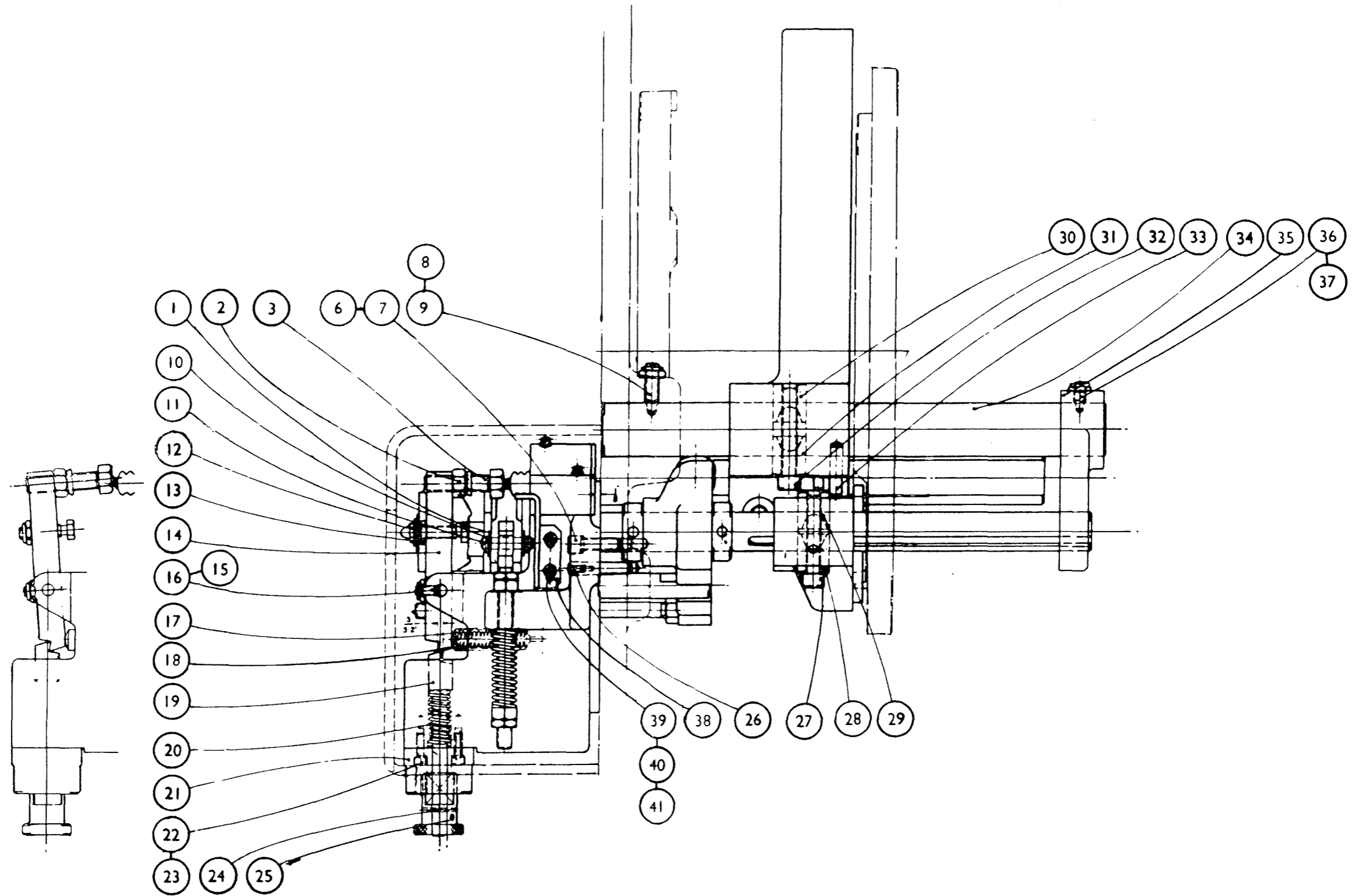

Drg No.154Z1B ----- Automatic Stop - Front and Rear

1.	154X126A	Support Block
2.	125/1620	1/4" Taper Pin 1.1/4" long
3.	155/0532	5/16" B.S.F. Socket Head Cap Screw 2" long
4.	154/05	5/16" Spring Washer
5.	155/0516	5/16" B.S.F. Socket Head Cap Screw 1" long
6.	154/05	5/16" Spring Washer
7.	125/1620	1/4" Taper Pin 1.1/4" long
8.	154V125B	Pusher Bracket
9.	155/0410	1/4" B.S.F. Socket Head Cap Screw
10.	154/04	1/4" Spring Washer
11.	154X130	Block
12.	154Z124B	Lower Aligning Disc Carrier
13.	153X164	1/4" Compression Spring 2" long
14.	145/108	1/4" Compression Spring 2" long
15.	125/1616	1/4" Taper Pin 1" long
16.	154V140	Lower Guide Bar
17.	156/208	2BA Socket Head Cap Screw 1/2" long
18.	122/1244	Key
19.	155/0416	1/4" B.S.F. Socket Head Cap Screw 1" long
20.	154/04	1/4" Spring Washer
21.	153X163A	Stop Screw
22.	153X138A	Pivot Screw
23.	173/06L	3/8" B.S.F. Hexagon Locknut
24.	154Z123B	Upper Aligning Disc Carrier
25.	155/0416	1/4" B.S.F. Socket Head Cap Screw 1" long
26.	154/04	1/4" Spring Washer
27.	125/1616	1/4" Taper Pin 1" long
28.	154V139	Upper Guide Bar
29.	154X127	Key
30.	156/208	2BA Socket Head Cap Screw 1/2" long
31.	154Y128	Cover

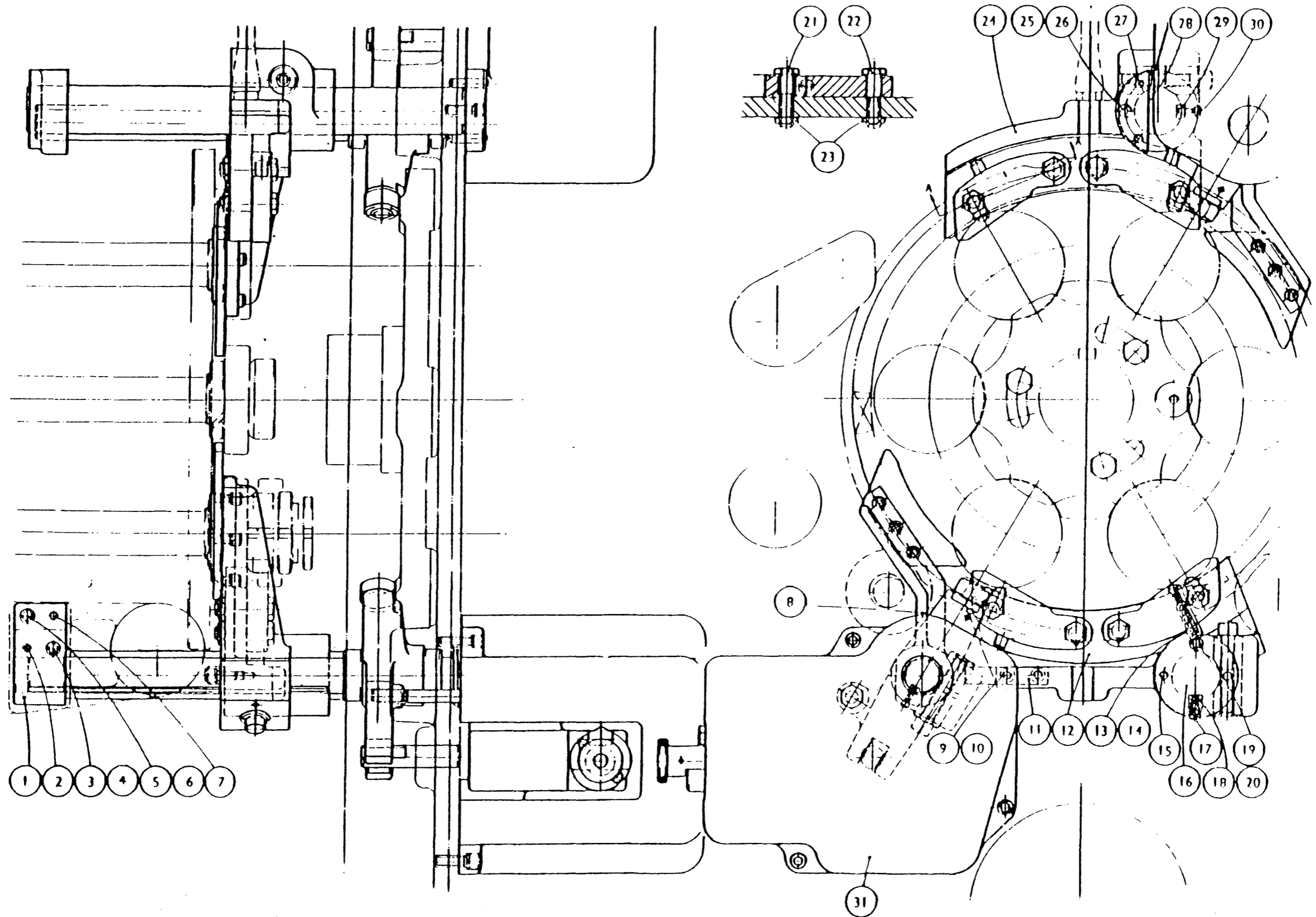

154 Z 1B AUTOMATIC STOP FRONT & REAR

1.	FX2477	Bearing Housing
2.	173/06L	3/8" B.S.F. Hexagon Locknut
3.	173/06	3/8" B.S.F. Hexagon Nut
4.	210/40	5/16" V.S.F. Purefoy Thumb Screw
5.	153/05	Soft Pad for 5/16" Screw
6.	156X130	Adjusting Screw
7.	154/07	7/16" Spring Washer
8.	155/0720	7/16" B.S.F. Hexagon Socket Head Cap Screw 1.1/4" long
9.	156X128A	Plunger Spring
10.	118X141	Spring Retaining Plug
11.	158X124A	Plunger
12.	156X133	Eccentric Pin
15.	156X113	Collet Operating Shoe
16.	156X110	Shoe Pin
17.	156X109	Collet Lever Pivot
18.	154/06	3/8" B.S.F. Lock Washer
19.	155/0620	3/8" B.S.F. Hexagon Socket Head Cap Screw 1.1/4" long
20.	156Y105B	Collet Operating Lever
21.	158X112	Roller for Collet Operation
22.	125/1628	1/4" dia. Solid Taper Pin 1.3/4" long
23.	158X107A	Cam Roller Pin
24.	225/3050	Copper Tubing 3/16" dia. 3/32" bore
25.	225/3	Tube Clip for 3/16" dia. Tube Type A
26.	186/206	2BA Cheese Head Slotted Screw 3/8" long
27.	156X103	Pegged Cap
30.	143/0612/B	3/16" dia. Grooved Pin 3/4" long
31.	236/242824	Oil Retaining Bush 1.1/2" x 1.3/4" x 1.1/2"
32.	156X104A	Collet Operating Link
33.	158X113A	Guide Bar
34.	158Z103A	Bracket for Levers
37.	173/07	7/16" B.S.F. Hexagon Nut
38.	173/07L	7/16" B.S.F. Hexagon Locknut
39.	156X131A	Stop Rod
40.	236/222624	Oil Retaining Bush 1.3/8" x 1.5/8" x 1.1/2"
41.	156Z101A	Collet Operating Slide
42.	236/222624	Oil Retaining Bush 1.3/8" x 1.5/8" x 1.1/2"
43.	236/161810	Oil Retaining Bush 1" x 1.7/8" x 5/8"
44.	173/06L	1/8" B.S.F. Hexagon Locknut
45.	182/0616	1/8" B.S.F. Hexagon Set Screw Taper Point 1" long
46.	101/11	External Circlip 1" dia.
47.	156X132	Link Pin
48.	236/161810	Oil Retaining Bush 1" x 1.1/8" x 5/8"
49.	182/0412	1/4" B.S.F. Hexagon Socket Head Screw Taper Point 3/4" long
50.	173/04L	1/4" B.S.F. Hexagon Locknut

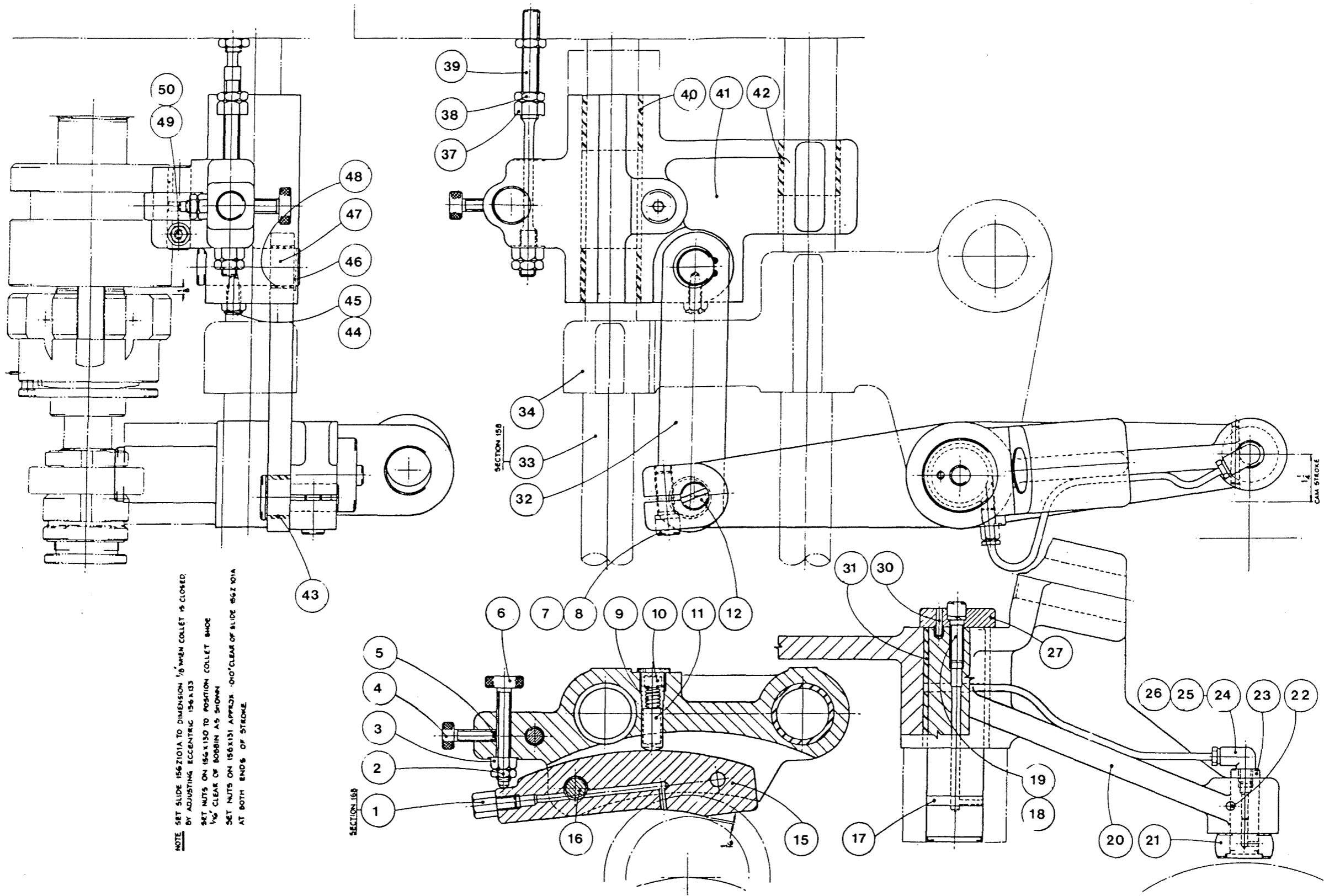

NOTE SET SLIDE 156Z101A TO DIMENSION $\frac{1}{8}$ " WHEN COLLET IS CLOSED BY ADJUSTING ECCENTRIC 156A103 SET NUTS ON 156G1150 TO POSITION COLLET SHADE $\frac{1}{16}$ " CLEAR OF BOBBIN AS SHOWN SET NUTS ON 156X131 APPROX. 0.010 " CLEAR OF SLIDE 156Z101A AT BOTH ENDS OF STROKE

WICKMAN MACHINE TOOL MANUFACTURING CO. LTD.
COVENTRY · ENGLAND.

COPYRIGHT © THE DRAWING AND DESIGN IS THE PROPERTY OF WICKMAN MACHINE TOOL MANUFACTURING CO. LTD. COVERED BY A PATENT AND COPYRIGHTED BY THE COMPANY. NO PART OF THIS DRAWING IS TO BE REPRODUCED OR TRANSMITTED IN ANY FORM OR BY ANY MEANS WITHOUT THE WRITTEN PERMISSION OF WICKMAN MACHINE TOOL MANUFACTURING CO. LTD.

DESCRIPTION
ARRANGEMENT OF COLLET. OPERATING MECHANISM

SCALE: FULL SIZE
DRAWN: WBG MAY 79
CHECKED: C.P.H. 24.7.79
MATERIAL: L.O.P. 156 1A, 2A, 3

156	1-6	156Z1B
ARRANGEMENT	SECTION	MACHINE

FIRST USED ON	
LAST USED ON	
SUPERNOUS	156 Z 1A
SUPERSEDED BY	
ALTERATIONS	
ISSUED	1004584 WBG 1979
U & B LIMIT HOLES TO B 164 1981	
REMOVE ALL SHARP CORNERS UNLESS OTHERWISE STATED	
CLEARANCE ON MACHINING DIMENSIONS: 0.01 UNLESS OTHERWISE STATED	
AMERICAN PROJECTION	
R	ROUGH MACHINE
FF	FINISH MACHINE
FT	GRIND OR EQUIVALENT
	RAW MATERIAL
MARK DRG. IN AT	
DRG. NO. 156Z1B	

Drg No.157Z1A ----- Collet Operation - Rear

1. 173/06 3/8" B.S.F. Hexagon Nut
2. 168X177 Pipe Support
3. 558X128 Spring
4. 558X125B Plunger Housing
5. 157X112 Pin
6. 558X126B Plunger
7. 558X127A Knob
8. 156X132 Link Pin
9. 101/11 External Shaft 1" dia.
10. 236/161810 Oil Retaining Bush 1" x 1.1/8" x 5/8"
11. 182/0616 3/8" B.S.F. Socket Head Set Screw Taper Point
1" long
12. 173/061 3/8" B.S.F. Hexagon Locknut
13. 157X104 Collet Operating Link
14. 236/161810 Oil Retaining Bush 1" x 1.1/8" x 5/8"
15. 156X131A Stop Rod
16. 173/07L 7/16" B.S.F. Hexagon Locknut
17. 173/07 7/16" B.S.F. Hexagon Nut
18. 159Z103 Bracket for Levers
19. 158X113A Guide
20. 236/222624 Oil Retaining Bush 1.3/8" x 1.5/8" x 1.1/2"
21. 157Z101A Collet Operating Slide
22. 236/222624 Oil Retaining Bush 1.3/8" x 1.5/8" x 1.1/2"
23. 210/2525 11/16" Yellow Indicating Washer
24. 212/9018 1/8" B.S.P. Autolub Nipple 90 deg.
25. 212/9018 1/8" B.S.P. Autolub Nipple 90 deg.
26. 210/2525 11/16" Yellow Indicating Washer
27. 210/2525 11/16" Yellow Indicating Washer
28. 212/9018 1/8" B.S.P. Autolub Nipple 90 deg.
29. 154/07 7/16" Spring Washer
30. 155/0720 7/16" B.S.F. Socket Head Cap Screw 1.1/4" long
31. 156X133 Eccentric Pin
32. 158X124A Plunger
33. 118X141 Spring Retaining Plug
34. 156X128A Plunger Spring
35. 143/0613B 3/16" dia. Grooved Pin 3/4" long
36. 154/06 3/8" Spring Washer
37. 155/0620 3/8" B.S.F. Socket Head Cap Screw 1.1/4" long
38. 156X103 Pegged Cap
39. 157Y115A Collet Operating Cam
40. 212/04 1/4" B.S.F. Autolub Nipple
41. 210/1725 9/16" Yellow Indicating Washer
42. 158X107A Cam Roller Pin
43. 125/1628 1/4" dia. Taper Pin 1.3/4" long
44. 158X112 Roller for Collet Operation
45. 156Y105B Collet Operating Lever
46. 156X109 Collet Lever Pivot
47. 236/242824 Oil Retaining Bush 1.1/2" x 1.3/4" x 1.1/2"
48. 157X110 Shoe Pin
49. 182/0412 1/4" B.S.F. Socket Head Set Screw Taper Point
3/4" long
50. 157X111 Nut
51. 157X113A Collet Operating Shoe

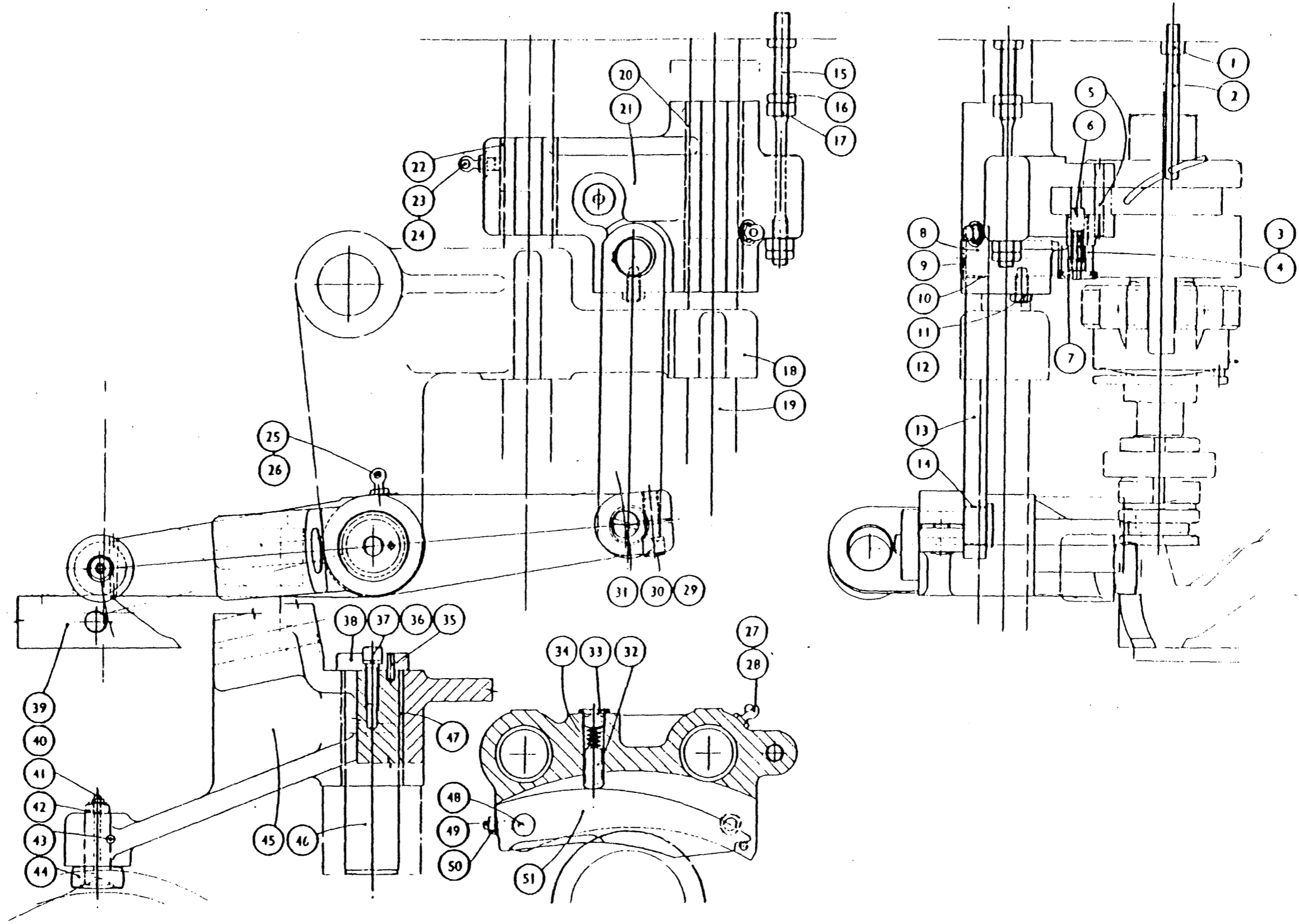

157 Z 1A

COLLET OPERATION - REAR

Drq No.	158Z1A	Bar Feed
1	154/04	5/16" Spring Washer
2.	155/0516	5/16" B.S.F. Socket Head Cap Screw 1" long
3.	154/06	3/8" Spring Washer
4.	155/0616	3/8" B.S.F. Socket Head Cap Screw
5.	158X134A	End Plate
6.	158X113C	Guide Bar
7.	210/2525	11/16" Yellow Indicating Washer
8.	212/18	1/8" B.S.P. Autolub Nipple
9.	173/12L	3/4" B.S.F. Hexagon Locknut
10.	130/12	3/4" Washer
11.	158X164A	Eccentric Roller Pin
12.	175X115	Roller
13.	158X155	Retaining Plate
14.	154/05	5/16" Spring Washer
15.	155/0516	5/16" B.S.F. Socket Head Cap Screw 1" long
16.	158X151	Spring Stud
17.	154/05	5/16" Spring Washer
18.	155/0516	5/16" B.S.F. Socket Head Cap Screw 1" long
19.	143/0824B	1/4" dia. Pin 1.1/2" long
20.	236/222624	Oil Retaining Bush 1.3/8" x 1.5/8" x 1.1/2"
21.	158X175	Latch
22.	MSC195	Morris Spring
23.	158X174	Plunger
24.	158X171	Spring Cap
25.	210/2525	11/16" Yellow Indicating Washer
26.	212/9018	1/8" B.S.P. Autolub Nipple
27.	158X178A	Nut
28.	258X181	Bush
29.	158X153	Pressure Plate
30.	150X161	Compression Spring
30A.	159X161	Compression Spring on Double Bar Feed Machine
31.	158X152	Spring Guide
32.	203/10L	5/8" B.S.F. self Locking Nut
33.	599AX108	Pusher Connection
34.	158Z103B	Bracket for Lever
35.	158X1/2	Inner Link Pivot
36.	158Z101B	Bar Feed Slide
37.	236/222624	Oil Retaining Bush 1.3/8" x 1.5/8" x 1.1/2"
38.	212/18	1/8" B.S.P. Autolub Nipple
39.	210/2525	11/16" Yellow Indicating Washer
40.	173/05	5/16" B.S.F. Hexagon Nut
41.	188/0540	5/16" B.S.F. Square Head Set Screw 2.1/2" long
42.	158X176A	Spacer
43.	158V169A	Link Block
44.	173/04	1/4" B.S.F. Hexagon Nut
45.	182/0420	1/4" B.S.F. Socket Screw Taper Point 1.1/4" long
46.	158X170	Bar Feed Link
47.	156/206	2BA Socket Head Cap Screw 3/8" long
48.	154/03	5/16" Spring Washer
49.	172X107B	Instruction Plate
50.	165/206	2BA Round Head Set Screw 3/8" long
51.	158X117A	Guide Washer
52.	167/0824	1/2" B.S.F. Hexagon Head Set Screw 1.1/4" long
54.	158X157B	Guide Bar
55.	158Z104G	Bar Feed Lever
56.	236/141810	Oil Retaining Bush 7/8" x 1.1/8" x 5/8"
57.	158X137	Slotted Washer

58.	NP/F204	5/8" B.S.F. Pinnacle Nut Type "P"
59.	156/206	2BA Socket Head Cap Screw 3/8" long
60.	154/03	3/16" Spring Washer
61.	125/1628	1/4" Taper Pin 1.1/4" long
62.	158X108A	Pivot Bolt
63.	158X127A	Outer-Link Pivot
64.	236/222624	Oil Retaining Bush 1.3/8" x 1.5/8" x 1.1/2"
65.	158X173	Pivot
66.	139/18	1/2" Taper Dowel 2.5/8" long
67.	236/222624	Oil Retaining Bush 1.3/8" x 1.5/8" x 1.1/2"

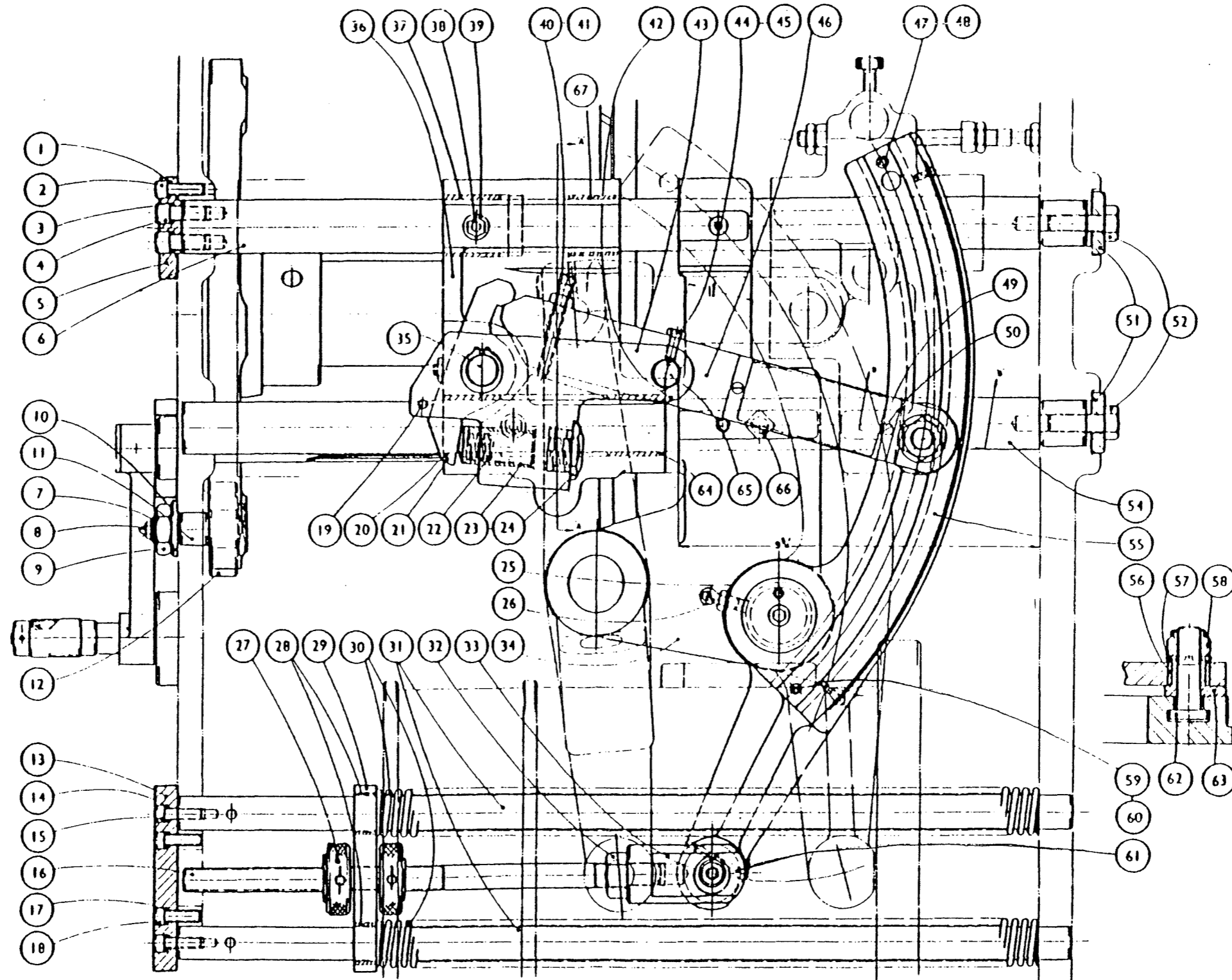

Drg No.158Z2A Bar Feed

1	158Y150B	Driving Dics
2.	125/3260	1/2" Taper Pin 3.3/4" long
3.	158Y158A	Thrust Ring
4.	155/0720	7/16" B.S.F. Socket Head Set Screw 1.1/2" long
5.	154/07	7/16" Spring Washer
6.	173/06	3/8" Hexagon Nut
7.	130/06	3/8" Flat Washer
8.	158X126A	Splined Shaft
9.	125/1620	1/4" Taper Pin 1.1/4" long
10.	155/0516	5/16" Socket Head Cap Screw 1" long
11.	154/05	5/16" Spring Washer
12.	158X132B	Lever
13.	125/0816	1/8" Taper Pin 1" long
14.	158X159	Plunger
15.	158X156	Plunger Knob
16.	MSC.155	Morris Spring
17.	158X154	Spring Housing
18.	158X177B	Plate
19.	154/04	1/4" Spring Washer
20.	155/0416	1/4" B.S.F. Socket Head Cap Screw 1" long
21.	173/05L	5/16" Hexagon Locknut
22.	182/0516	5/16" B.S.F. Socket Head set Screw Taper Point 1" long
23.	158X172	Inner Link Pivot
24.	236/14810	Oil Retaining Bush 7/8" x 1.1/8" x 5/8"
25.	101/9	External Circlip 7/8" dia.
26.	236/141807	Oil Retaining Bush 7/8" x 1.1/8" x 7/16"
27.	158X163	Special Taper Pin
28.	165/206	2BA Round Head Set Screw 3/8" long
29.	158Y149	Bar Feed Scale

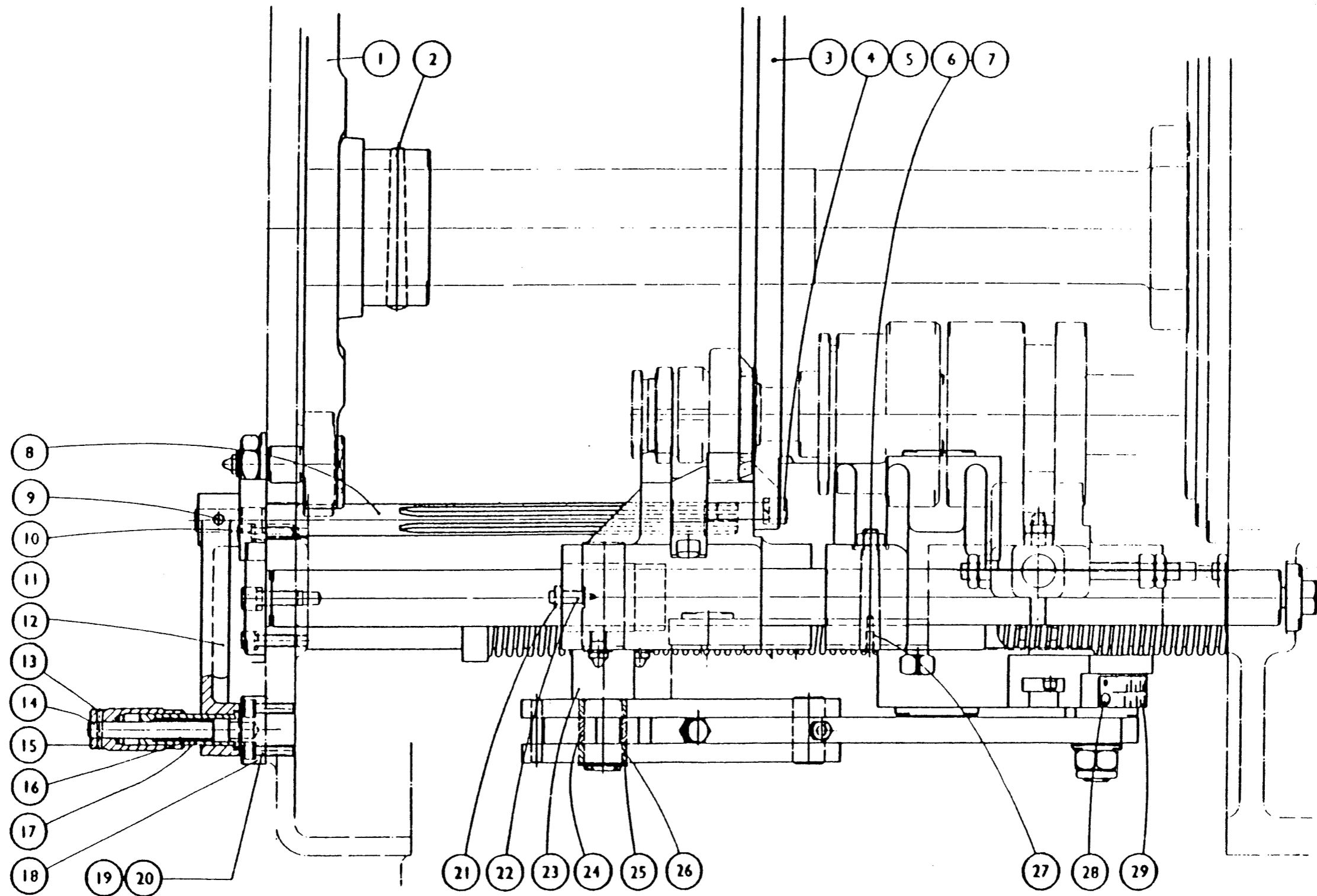

Drg No.158Z3B ----- Bar Feed Mechanism

1. 158X105C Bar Feed Shoe
2. 158X179 Spring
3. 158X124A Plunger
4. 178/0640 3/8" B.S.F Socket Head Screw - Dog Point 2.1/2" Long
5. 203/06L 3/8" B.S.F Locknut
6. 158X140 Splined Bush
7. 158X114B Feed Lever Pivot
8. 158X112A Roller
9. 158X160B Cam Roller Pin
10. 203/06L 3/8" B.S.F Locknut
11. 182/0616 3/8" B.S.F Socket Set Screw 1" Long
12. 158X122 Spigotted Cap
13. 143/0607B 3/16" Grooved Pin 7/16" Long
14. 155/0616 3/8" B.S.F Socket Head Cap Screw 1" Long
15. 236/242824 Oil Retaining Bush 1.1/2"x1.3/4"x1.1/2"
16. 236/121414 Oil Retaining Bush 3/4"x7/8"x7/8"
17. 101/6 External Circlip 3/4" dia.
18. 176/0406 1/4" B.S.F Socket Set Screw 3/8" Long
19. 158X133A Bearing Block

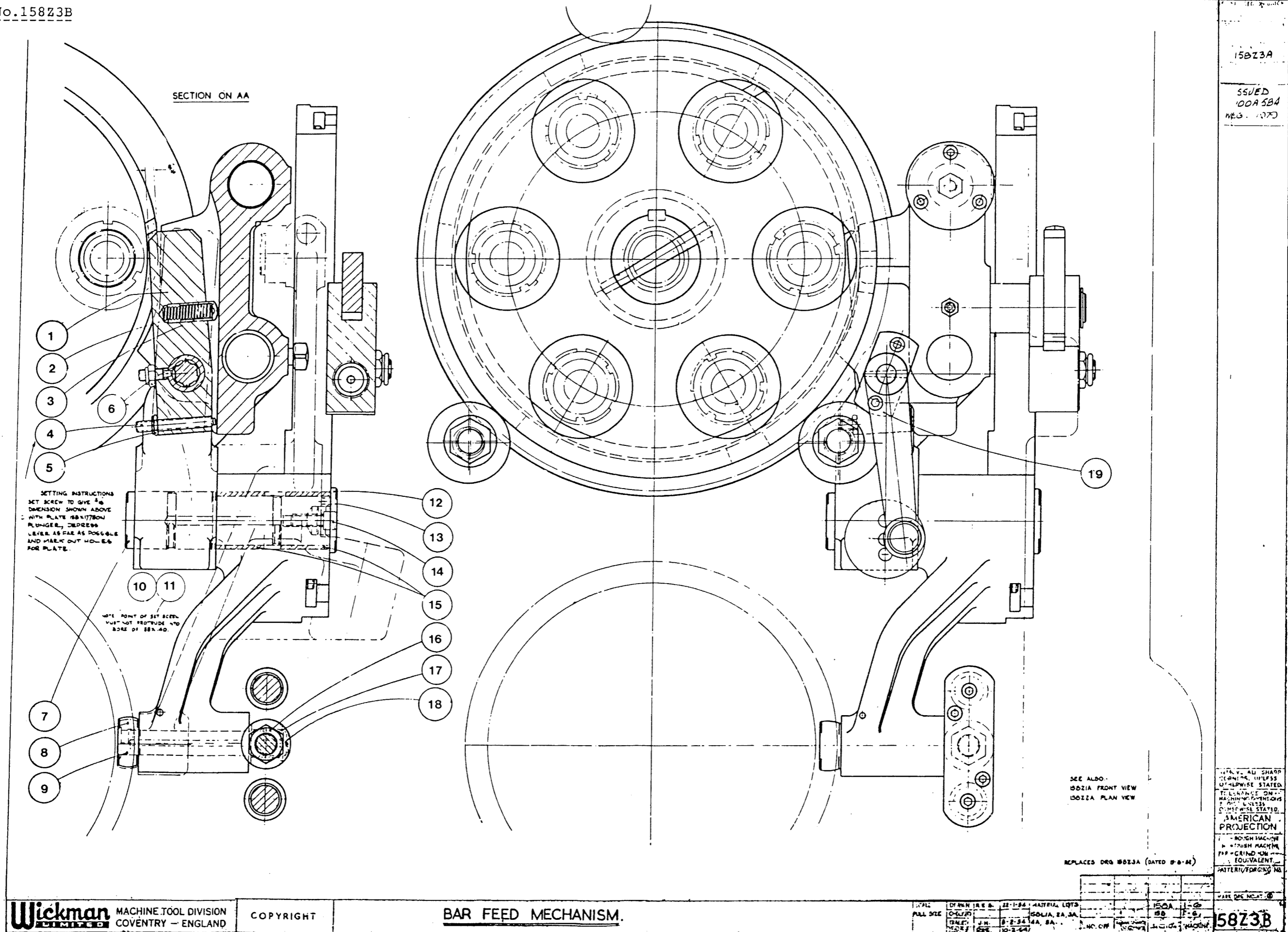

158Z3A

ISSUED
 100A 584
 NEG. 1070

ALL V. AD SHARP
 CORNERS, UNLESS
 OTHERWISE STATED.
 TO LUNGE ON
 MACHINING DIMENSIONS
 2.00 & OVER
 OTHERWISE STATED.
 AMERICAN
 PROJECTION
 1 - ROUGH MACHINE
 2 - FINISH MACHINE
 3 - GRIND OR
 EQUIVALENT
 MATERIAL/DRIVING NO.

Drg No.159Z1B Bar Feed

1.	158X108A	Pivot Bolt
2.	158X127A	Outer-Link Pivot
3.	236/141810	Oil Retaining Bush 7/8" x 1.1/2" x 5/8"
4.	F204	5/8" B.S.F. Pinnacle Nut
5.	158X137	Slotted Washer
6.	198/16	1/2" Lockwasher
7.	167/0824	1/2" B.S.F. Hexagon Head Set Screw 1.1/2" long
8.	158X117A	Guide Washer
9.	158X157B	Guide Bar
10.	165/206	2BA Round Head Set Screw 3/8" long
11.	158Y109	Bar Feed Scale
12.	156/206	2BA Socket Head Cap Screw 3/8" long
13.	154/03	2BA Spring Washer
14.	158X119A	Bar Feed Link
17.	236/222624	Oil Retaining Bush 1.3/8" x 1.5/8" x 1.1/2"
18.	158X176A	Spacer
19.	159Z101B	Bar Feed SSlide - Rear
20.	158X126A	Splined Shaft
21.	159Z104B	Bar Feed Lever
22.	155/0832	1/2" B.S.F. Socket Head Cap SCrew 2" long
23.	154/08	1/2" Spring Washer
24.	139/18	1/2" TAper Pin 2.5/8" long
25.	159Z103D	Bracket for Levers
26.	236/222624	Oil Retaining Bush 1.3/8" x 1.5/8" x 1.1/2"
29.	236/222624	Oil Retaining Bush 1.3/8" x 1.5/8" x 1.1/2"
30.	159Y115A	Pivot Bracket
31.	159X117	Link Pivot
32.	155/0408	1/4" B.S.F. Socket Head Cap Screw 1/2" long
33.	154/04	1/4" Spring Washer
34.	158X132B	Lever
35.	125/1620	1/4" Taper Pin 1.1/4" long
36.	158X133A	Bearing Block
37.	155/0516	5/16" B.S.F. Socket Head Cap Screw 1" long
38.	154/05	5/16" B.S.F. Spring Washer
39.	122Z102B	End Bracket
40.	236/222624	Oil Retaining Bush 1.3/8" x 1.5/8" x 1.5/8" long
41.	168X517A	Adaptor

FIRST USED ON BATCH
LAST USED ON BATCH
SUPERSEDED 159Z1A
SUPERSEDED BY
ALTERATIONS
ISSUED 10045B4 W.G. 972

NOTE: ADJUST SPACER 158 X 176A (MARKED THIS #) TO GIVE 1/2" CLEARANCE BETWEEN ROLLER AND CAM AT ALL STROKE SETTINGS. BRACKET 159Y115 TO BE SET IN ZERO POSITION, AND LEVER 159 Z 104 A IN FORWARD POSITION.

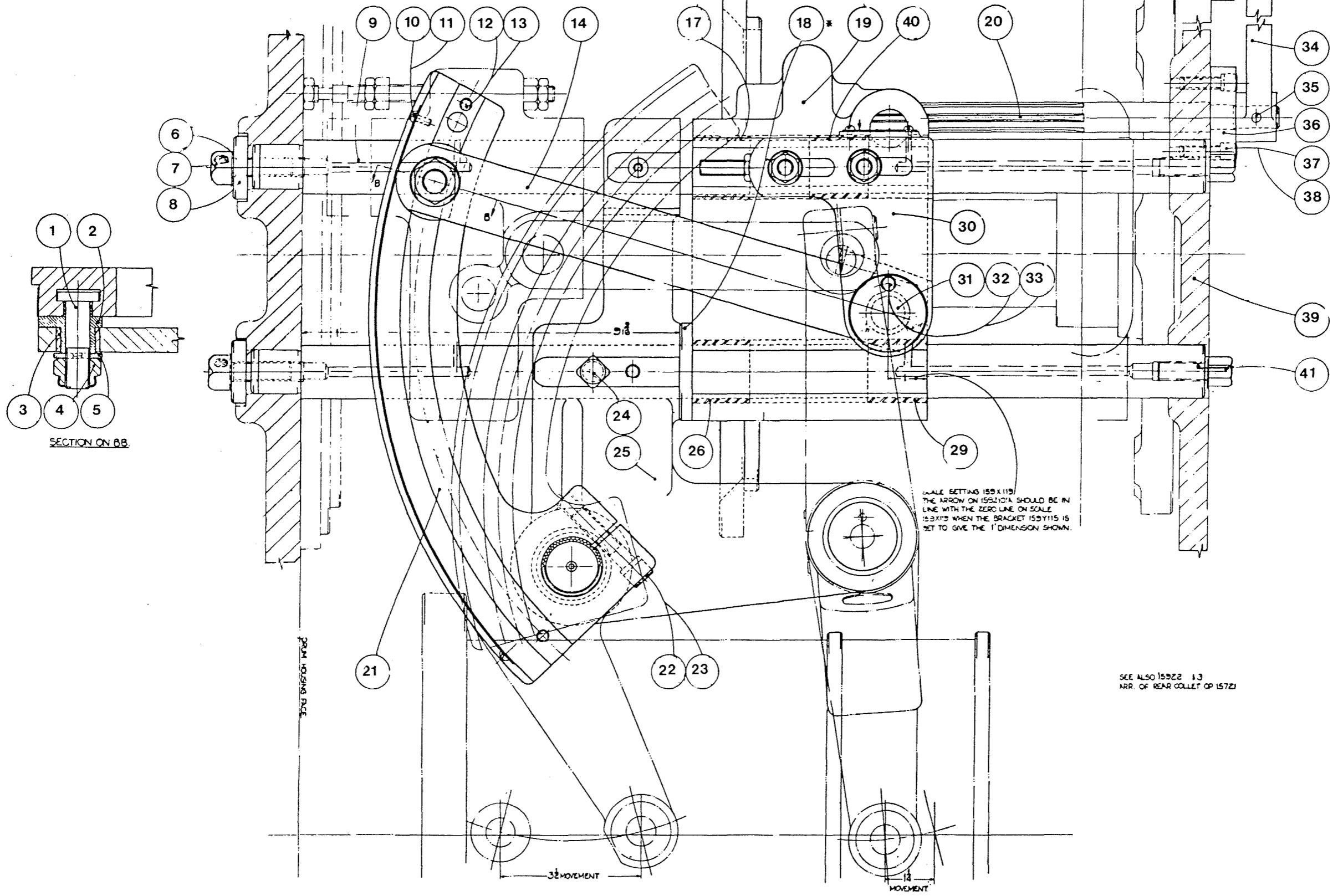

SCALE SETTING 159 X 115 THE ARROW ON 159Z101A SHOULD BE IN LINE WITH THE ZERO LINE ON SCALE. 159X115 WHEN THE BRACKET 159Y115 IS SET TO GIVE THE 1" DIMENSION SHOWN.

SEE ALSO 159Z2 1.3 ARR. OF REAR COLLET OF 157Z1

REMOVE ALL SHARP CORNERS, UNLESS OTHERWISE STATED.
TOLERANCE ON MACHINING DIMENSIONS ±.010" UNLESS OTHERWISE STATED.
AMERICAN PROJECTION.



BAR FEED MECHANISM REAR (OPTIONAL EXTRA) SECTION

159Z1B

Drq No.	159Z2A	Bar Feed
1.	173/06	3/8" B.S.F. Hexagon Nut
2.	130/06	3/8" Plain Washer
3.	158X163	Special Taper Pin
4.	159X118	Stud
5.	130/07	7/16" Plain Washer
6.	NP/F144	7/16" B.S.F. Pinnacle Nut
7.	165/404	4BA Round Head Set Screw 1/4" long
8.	159X119	Scale
9.	158X154	Spring Housing
10.	158X156	Plunger Knob
11.	125/0816	1/8" Taper Pin 1" long
12.	158X159	Plunger
13.	MSC155	Morris Spring
14.	178/0632	3/8" B.S.F. Socket Set Screw x 2" long
15.	173/06	3/8" B.S.F. Nut

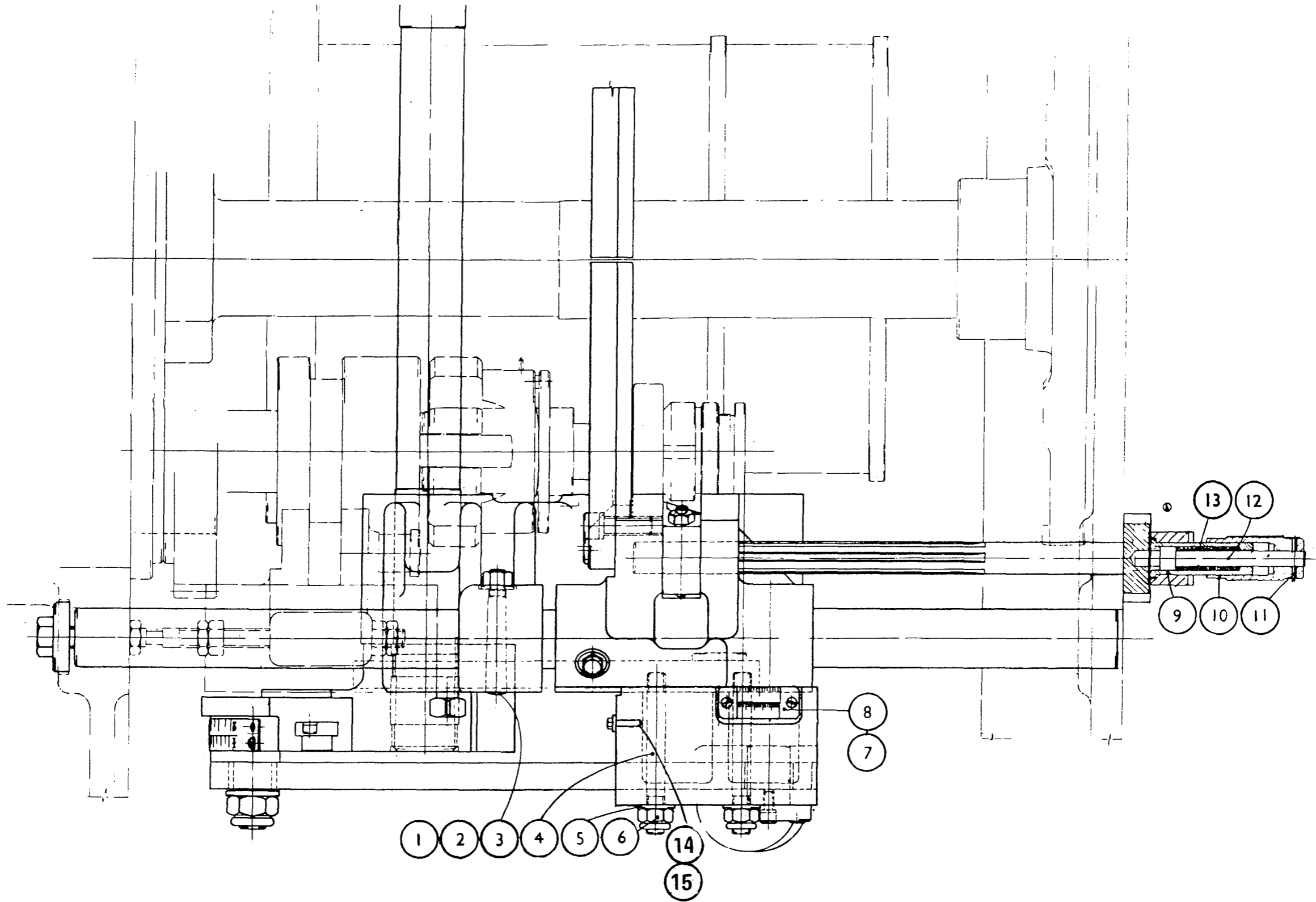

Drg No.159Z3A Bar Feed - Rear

1. 158X105B Bar Feed Shoe
4. 158X179 Morris Spring
5. 158X124A Plunger
6. 212/9018 1/8" B.S.P. Autoclub Nipple 90 deg.
7. 210/2525 11/16" Yellow Indicating Washer
8. 236/242836 Oil Retaining Bush 1.1/2" x 1.3/4" x 2.1/4"
9. 159Y114 Feed Lever Shaft
10. 212/9018 1/8" B.S.P. Autolub Nipple 90 deg.
11. 210/2525 11/16" Yellow Indicating Washer
12. 236/242836 Oil Retaining Bush 1.1/2" x 1.3/4" x 2.1/4"
13. 159X122 Taper Pin
14. 155/0416 1/4" B.S.F. Socket Head Cap Screw 1" long
15. 154/04 1/4" Spring Washer
16. 158X177 Plate
17. 159Y116A Thrust Ring
18. 155/0720 7/16" B.S.F. Socket Head Cap Screw 1.1/4" long
19. 154/07 7/16" Spring Washer
20. 158X140 Splined Bush
21. 178/0640 3/8" Set Screw 2.1/2" long
22. 203/06L 3/8" B.S.F. Locknut
23. 203/06L 3/8" B.S.F. Locknut
24. 182/0616 3/8" B.S.F. Set Screw 1" long

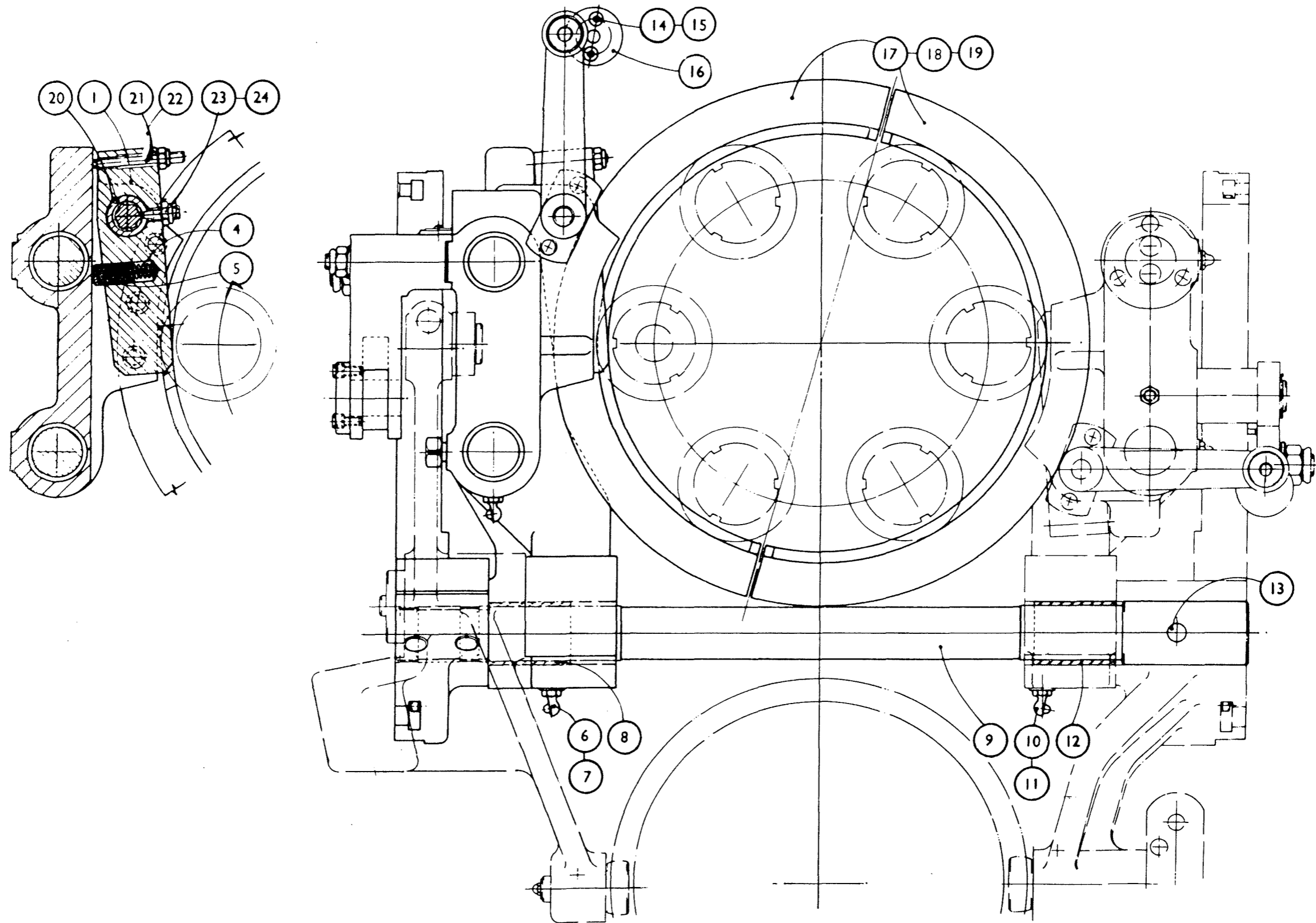

Drg No.160Z1 ----- Long Bar Feed

1.	158X133A	Bearing Block
2.	155/0516	5/16" B.S.F. Hexagon Socket Head Cap Screw 1" long
3.	154/05	5/16" Dia. Spring Washer
4.	156/206	2BA Hexagon Socket Head Cap Screw 3/8" long
5.	154/03	3/16" Dia. Spring Washer
6.	158X127A	Outer Link Pivot
7.	236/141810	Oil Retaining Bush
8.	158X137	Slotted Washer
9.	158X108A	Pivot Bolt
10.	203/10	5/8" B.S.F. Self-locking Hexagon Nut
11.	158X172	Inner Link Pivot
12.	236/141810	Oil Retaining Bush
13.	236/141807	Oil Retaining Bush
14.	101/9	External Circlip 7/8" dia.
15.	212/9018	1/8" B.S.P. Nipple
16.	210/2525	Yellow Indicator Washer
17.	178/0640	3/8" B.S.F. Hexagon Set Screw 2.1/2" long
18.	203/06L	3/8" B.S.F. Self-Locking Hexagon Locknut
19.	158X122	Spiggotted Cap
20.	143/0607B	3/16" Pin, 7/16" long
21.	155/0616	3/8" B.S.F. Hexagon Socket Head Cap Screw 1" long
22.	236/242824	Oil Retaining Bush
23.	236/121414	Oil Retaining Bush
24.	101/6	External Circlip
25.	212/04	1/4" B.S.F. Grease Nipple
26.	210/1725	Yellow Indicator Washer
27.	158X105C	Bar Feed Shoe
28.	158X179	Bar Feed Shoe Spring
29.	158X124A	Plunger
30.	203/06L	3/8" B.S.F. Self-locking Hexagon Locknut
31.	182/0616	3/4" B.S.F. Taper Point Set Screw 1" long
32.	158X140	Splined Bush
33.	158X114A	Feed Lever Pivot
34.	158X112A	Roller
35.	158X160A	Cam Roller Pin
36.	160X126	Splined Shaft
37.	125/1620	1/4" Dia. Taper Pin 1.1/4" long
38.	158X132B	Lever
39.	158X154	Spring Housing
40.	158X156	Plunger Knob
41.	125/0814	1/4" dia. Taper Pin, 7/8" long
42.	158X159	Plunger
43.	MSC155	Morris Spring (Comp)
44.	158X177B	Plate
45.	154/04	1/4" Dia. Spring Washer
46.	155/0416	1/4" B.S.F. Hexagon Socket Head Cap Screw 1" long
47.	160Z102	End Bracket
48.	154/05	5/16" Dia. Spring Washer
49.	155/0516	5/16" B.S.F. Hexagon Socket Head Cap Screw 1" long
50.	154/06	3/8" Dia. Spring Washer
51.	155/0616	3/8" B.S.F. Hexagon Socket Head Cap Screw 1" long
52.	158X134A	End Plate (Front)
53.	160X134	End Plate (Rear)
54.	173/12L	3/4" B.S.F. Hexagon Locknut
55.	130/12	3/4" B.S.F. Flat Washer
56.	210/2525	Yellow Indicator Washer

57.	212/0365	1/8" B.S.P. grease Nipple
58.	158X164A	Eccentric Roller Pin
59.	175X115	Roller
60.	158X155	Retaining Plate
61.	154/05	5/16" Dia. Spring Washer
62.	155/0516	5/16" B.S.F. Hexagon Socket Head Cap Screw 1" long
63.	158X151	Spring Stud
64.	154/05	5/16" Dia. Spring Washer
65.	155/0516	5/16" B.S.F. Socket Head Cap Screw 1" long
66.	158Y158A	Thrust Ring
67.	155/0720	6" B.S.F. Hexagon Socket Head Cap Screw 1.1/4" long
68.	154/07	7/16" Dia. Spring Washer
69.	203/05L	5/16" B.S.F. Hexagon Self-locking Locknut
70.	182/0516	5/16" B.S.F. Taper Point Set Screw
71.	212/18	1/8" B.S.P. Grease Nipple
72.	210/2525	Yellow Indicator Washer
73.	158X163	Special Taper Pin
74.	203/06L	3/8" B.S.F. Self-locking Hexagon Locknut
75.	130/06	3/8" B.S.F. Flat Washer
76.	160Y109	Bar Feed Scale
77.	165/206	2BA Round Head Set Screw 3/8" long
78.	158Z101B	Bar Feed Slide
79.	158X170	Bar Feed Link
80.	236/222624	Oil Retaining Bush
81.	188/0540	5/16" B.S.F. Square Head Set Screw 2.2/1" long
82.	203/05L	5/16" B.S.F. Self-locking Hexagon Locknut
83.	158V169A	Link Block
84.	182/0420	1/4" B.S.F. Taper Point Set Screw 1.1/4" long
85.	203/04L	1/4" B.S.F. self-Locking Hexagon Locknut
86.	158X173	Pivot
87.	172X107B	Instruction Plate
88.	165/204	2BA Round Head Set Screw 1/4" long
89.	158X175	Latch
90.	143/0824B	1/4" Dia. Pin, 1.1/2" long
91.	236/222624	Oil Retaining Bush
92.	158X174	Plunger
93.	MSC195	Morris Spring 3/4" outside diameter, 3.1/2" long
94.	158X171	Spring Cap
95.	236/222624	Oil Retaining Bush
96.	212/9018	1/8" B.S.P. Grease Nipple
97.	210/2525	Yellow Indicator Washer
98.	158X176A	Spacer
99.	158X153	Pressure Plate
100.	258X181	Bush
101.	160X113A	Guide Bar
102.	158X117A	Guide Washer
103.	167/0824	1/2" B.S.F. Hexagon Set Screw, 1.1/2" long
104.	198/16	1/2" B.S.F. Shakeproof Lock Washer
105.	160X157A	Guide Bar
106.	158X117A	Guide Washer
107.	167/0824	1/2" B.S.F. Hexagon Set Screw 1.1/3" long
108.	198/16	1/2" B.S.F. Shakeproof Lockl Washer
109.	139/18	Taper Dowel, 1/2" dia. x 2.5/8" long
110.	158Z103B	Bracket
111.	160Z104	Bar Feed Lever
112.	156/206	2BA Hexagon Socket Head Cap Screw 3/8" long
113.	154/03	3/16" Dia. Spring Washer
114.	158X178A	Locknut

115.	258X181	Bush
116.	198/18	5/8" B.S.F. Shakeproof Lock Washer
117.	159X161	Compression Spring
118.	160X152	Spring Guide
119.	203/10L	5/8" B.S.F. Hexagon Locknut
120.	599X108	Pusher Connection
121.	125/1628	1/4" dia. Taper Pin, 1.3/4" long
122.	236/222624	Oil Retaining Bush 1.3/8" x 1.5/8" x 1.1/2" long

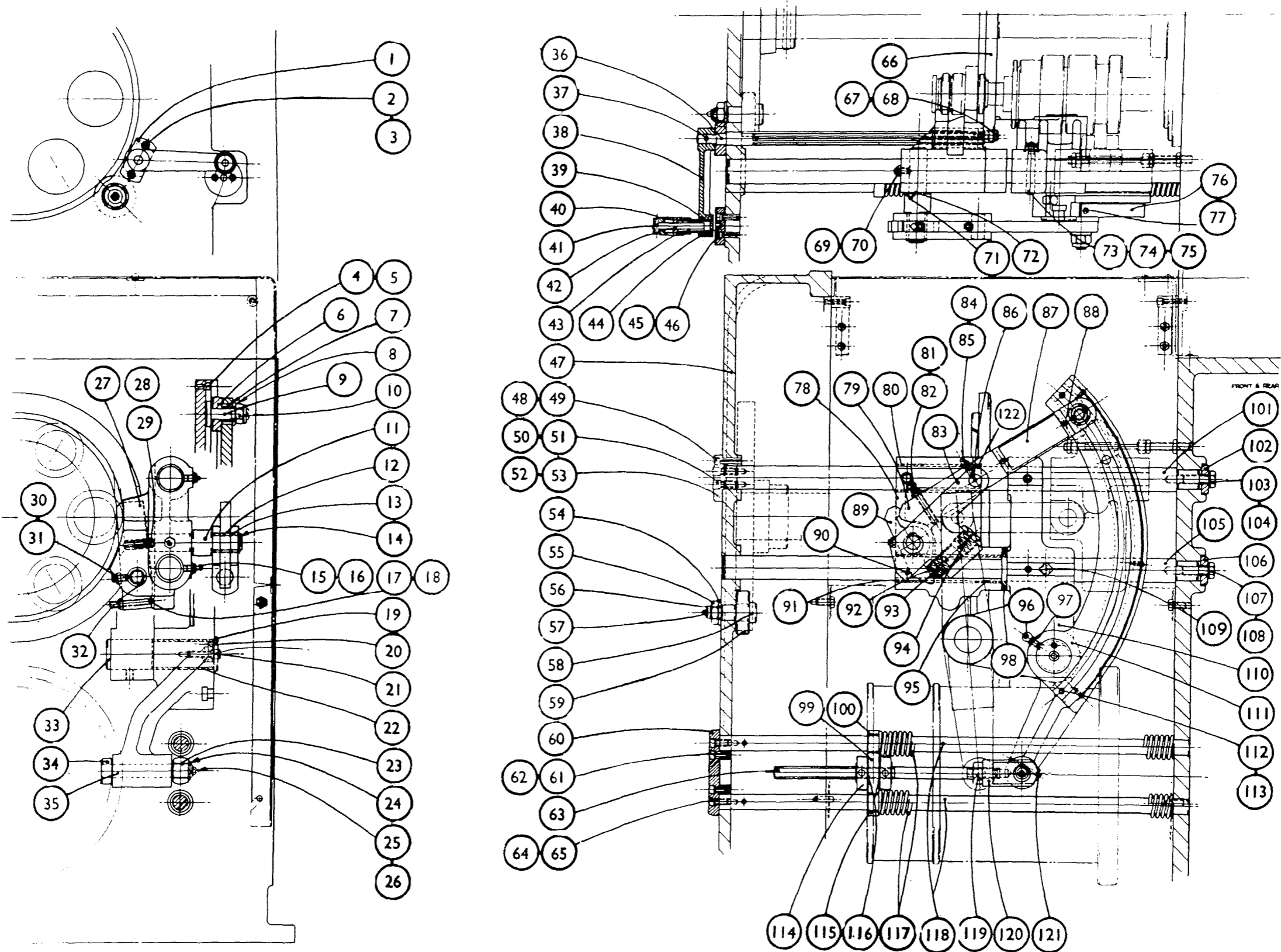

Long Bar Feed:

Drg No.160Z2 ----- Long Bar Feed

1.	MSC155	Morris Spring, 1/2" outside dia. x 2.1/2" long
2.	158X159	Plunger
3.	158X154	Spring Housing
4.	158X156	Plunger Knob
5.	125/0814	1/4" Dia. Taper Pin, 7/8" long
6.	203/10	5/8" B.S.F. self-locking Hexagon Nut
7.	158X137	Slotted Washer
8.	158X108A	Pivot Bolt
9.	158X127A	Outer Link Pivot
10.	236/141810	Oil Retaining Bush
11.	203/06L	3/8" B.S.F. Self-locking Hexagon Locknut
12.	136/06	3/8" B.S.F. Flat Washer
13.	158X163	Special Taper Pin
14.	159X118	Stud
15.	203/07	7/16" B.S.F. Self-locking Hexagon Nut
16.	130/07	7/16" B.S.F. Flat Washer
17.	159X119	Scale
18.	165/404	4BA Round Head Set Screw, 1/4" long
19.	160X113	Guide Bar
20.	165/206	2BA Round Head Set Screw 3/8" long
21.	160Y109	Bar Feed Seal
22.	156/206	2BA Hexagon Socket Head Cap Screw 3/8" long
23.	154/03	3/16" Spring Washer
24.	160X119	Bar Feed Link
25.	158X176A	Spacer
26.	212/18	1/8" B.S.P. Grease Nipple
27.	210/2525	Yellow Indicator Washer
28.	159Z101B	Bar Feed Slide - Rear
29.	159Y115A	Pivot Bracket
30.	160X126	Splined Shaft
31.	155/0408	1/4" B.S.F. Hexagon Socket Head Cap Screw 1" long
32.	154/04	1/4" Dia. Spring Washer
33.	159X117	Link
34.	167/0824	1/2" B.S.F. Hexagon Set Screw 1.1/2" long
35.	198/16	1/2" B.S.F. Shakeproof Lock Washer
36.	158X117A	Guide Washer
37.	159Z103D	Bracket
38.	160Y124	Bar Feed Lever - Rear
39.	139/18	1/2" Dia. Taper Dowel, 2.5/8" long
40.	155/0732	7/16" B.S.F. Hexagon Socket Head Cap Screw 2" long
41.	154/07	7/16" Dia. Spring Washer
42.	236/222624	Oil Retaining Bush
43.	212/9018	1/8" B.S.P. Grease Nipple
44.	210/2525	Yellow Indicator Washer
45.	158X132B	Lever
46.	158X133A	Bearing Block
47.	125/1620	1/4" Dia. Taper Pin, 1.1/4" long
48.	160X134	End Plate
49.	155/0616	3/8" B.S.F. Hexagon Socket Head Cap Screw 1" long
50.	154/06	3/8" Spring Washer
51.	155/0516	5/16" B.S.F. Hexagon Socket Head Cap Screw 1" long
52.	154/05	5/16" Spring Washer
53.	160X157	Guide Bar
54.	160Z102	End Bracket
55.	178/0640	3/8" B.S.F. Hexagon Set Screw 2.1/2" long
56.	203/06L	3/8" B.S.F. self-Locking Hexagon Locknut
57.	158X140	Splined Bush

58.	182/0616	3/8" B.S.F. Taper Point Set Screw 1" long
59.	203/06L	3/8" B.S.F. self-locking Hexagon Locknut
60.	158X179	Bar Feed Shoe Spring
61.	158X124A	Plunger
62.	158X105C	Bar Feed Shoe
63.	155/0416	1/4" B.S.F. Hexagon Socket Head Cap Screw 1" long
64.	154/04	1/4" Spring Washer
65.	158X177B	Plate
66.	159Y116A	Thrust Ring
67.	155/0720	7/16" B.S.F. Socket Head Cap Screw 1.1/4" long
68.	154/07	7/16" Spring Washer
69.	154/05	5/16" Spring Washer
70.	155/0516	5/16" B.S.F. Hexagon Socket Head Cap Screw 1" long
71.	236/242836	Oil Retaining Bush
72.	212/9018	1/8" B.S.P/ Grease Nipple
73.	210/2525	Yellow Indicator Washer
74.	125/3248	1/2" Dia. Taper Pin, 3" long
75.	236/242836	Oil Retaining Bush
76.	212/9018	1/8" B.S.P. Grease Nipple
77.	210/2525	Yellow Indicator Washer
78.	159Y114	Feed Lever Shaft

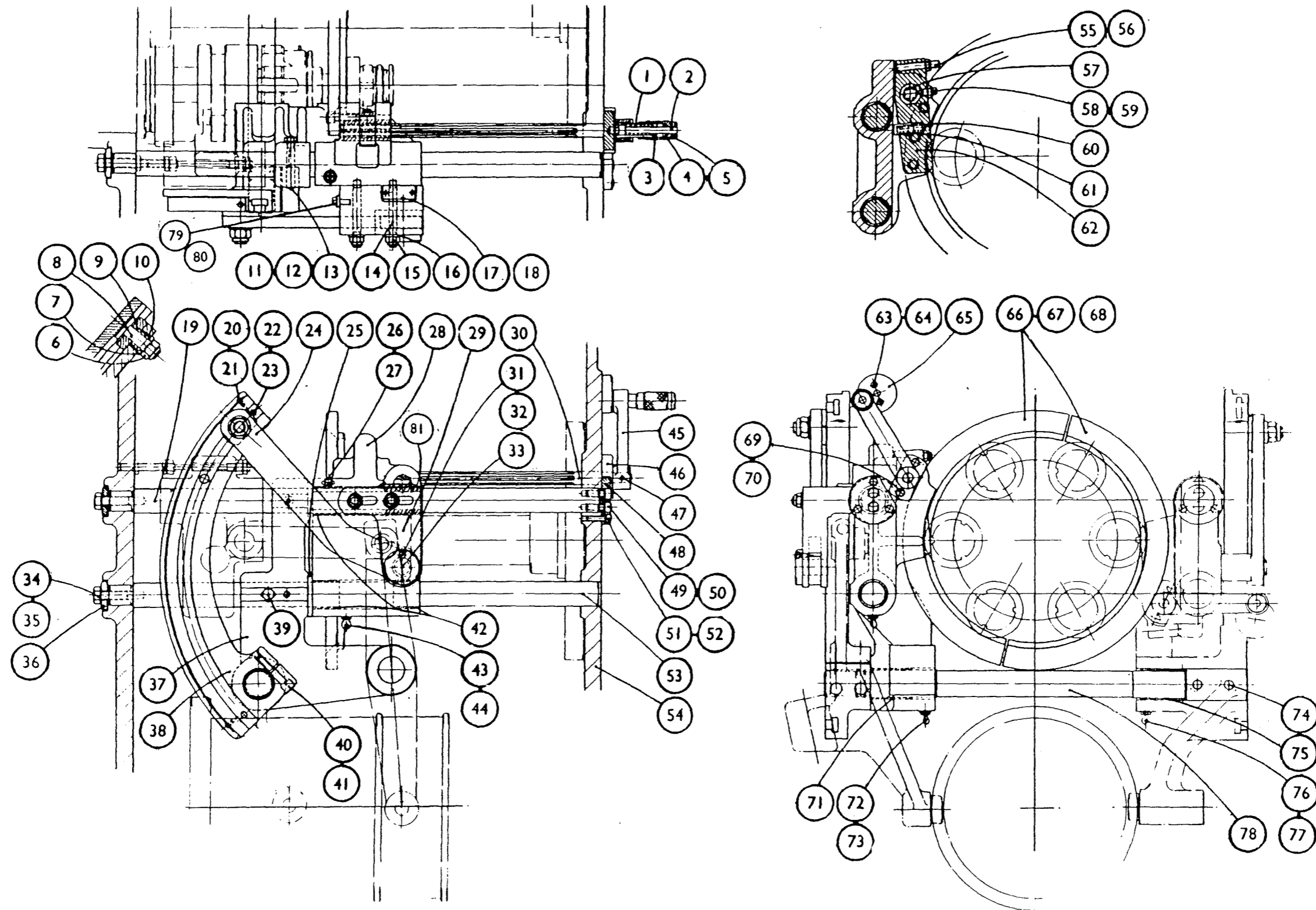

Long Bar Feed:

Drg No.160Z3 Long Bar Feed

1.	154/03	3/16" Dia. Spring Washer
2.	158Y150A	Driving Disc
3.	156/206	2BA Socket Head Cap Screw 3/8" long
4.	101X172	Key
5.	125/3260	1/2" Dia. Taper Pin, 3.3/4" long
6.	183/0620	3/8" B.S.F. Square Head Set Screw Taper Point 1" long
7.	203/06L	3/8" B.S.F. Self-locking Hexagon Nut
8.	160X138	Bearing Spacer
9.	155/0572	5/16" B.S.F. Hexagon Socket Head Cap Screw 4.1/2" long
10.	154/05	5/16" Dia. Spring Washer
11.	203/06L	3/8" B.S.F. Self-locking Hexagon Nut
12.	183/0620	3/8" B.S.F. Square Head Set Screw Taper Point, 1" long
13.	101Y169A	Stop Plate
14.	160Y114	Feed Tube Steady (Long Bar Feed M/c)
15.	126/1020	5/16" Dia. Dowel 1.1/4" long
16.	188/0740	7/16" B.S.F. Square Head Set Screw 2.1/2" long
17.	160X143	Modified Trip Shaft
18.	160X139	Upper Guide Bar
19.	160V141	Upper Guide Bar
20.	155/0412	1/4" B.S.F. Socket Head Cap Screw, 3/4" long
21.	154/04	1/4" Dia. Spring Washer
22.	125/1616	1/4" Dia. Taper Pin 1" long
23.	101X170	Stop Plate Bolt
24.	301X171	Key
25.	143/1012B	5/16" Dia. Mills Pin, 3/4" long
26.	160Y120	Driving Coupling
27.	101X173	Parallel Pin
28.	155/0620	3/8" B.S.F. Socket Head Cap Screw 1.1/4" long
29.	154/06	3/8" Dia. Spring Washer
30.	577X126	Knob
31.	577X123	Plunger Housing
32.	558X128	Spring
33.	577X125	Plunger
34.	160X140	Lower Guide Bar
35.	160V142	Lower Guide Bar
36.	155/0412	1/4" B.S.F. Socket Head Cap Screw, 3/4" long
37.	154/04	1/4" Dia. Spring Washer
38.	125/1616	1/4" Dia. Taper Pin 1" long

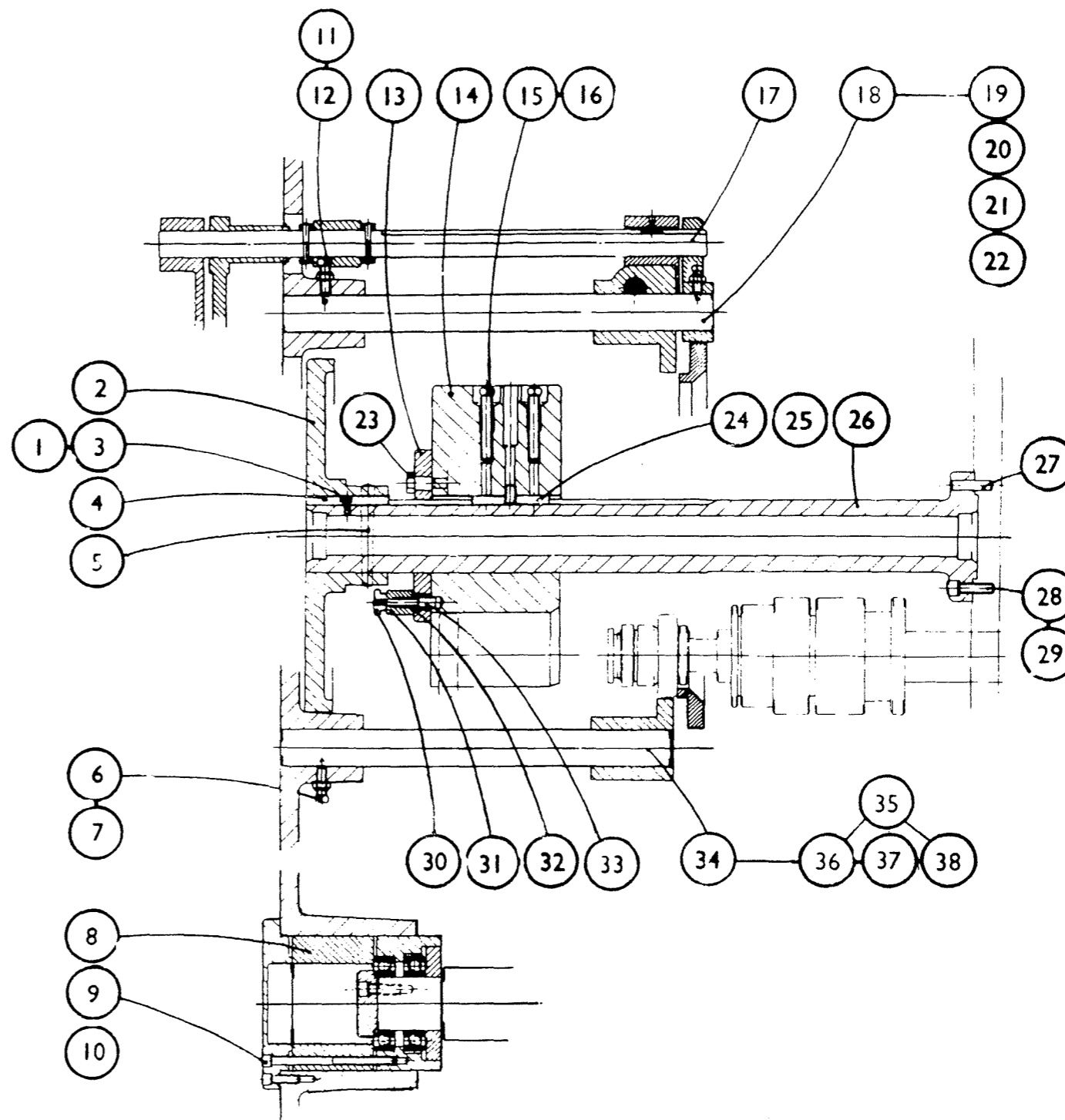
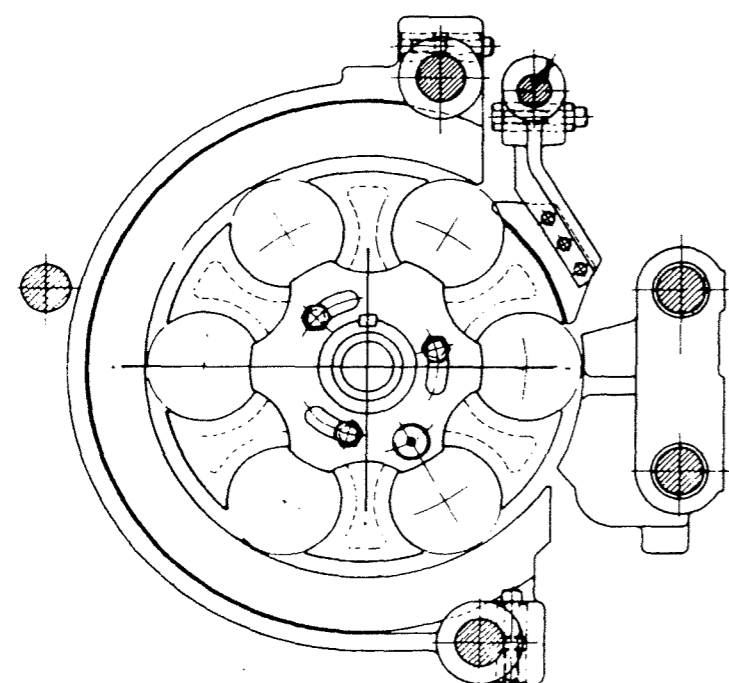

Long Bar Feed:

Drg No. 161Z1 ----- Drum Locking Operation

1.	236/202420	Oil Retaining Bush 1.1/4" x 1.1/2" x 1.1/4"
2.	150X120	Link Pin
3.	173/04	1/4" B.S.F. Hexagon Locknut
4.	176/0414	1/4" B.S.F. Socket Head Set Screw 7/8" long
5.	101/15	External Circlip 1.1/4" dia.
6.	161Y101B	Drum Locking Lever
7.	161X120A	Drum Locking Rod (Lower)
8.	161X118A	Spring Retaining Plug
9.	150X130	Cam Roller
10.	150X129	Cam Roller Pin
11.	125/1620	1/4" dia. Taper Pin 1.1/4" long
12.	161X117B	Spring
13.	125/0916	1/8" dia. Taper Pin 1" long
14.	161X122A	Nut
15.	161X116A	Spring Tube
16.	203/08L	1/2" B.S.F. Hexagon Locknut
17.	161X119A	Drum Locking Rod (Upper)
18.	203/08L	1/2" B.S.F. Hexagon Locknut
19.	161X121A	Drum Locking Rod, End
20.	150X120	Link Pin
21.	176/0412	1/4" B.S.F. Socket Head Set Screw 3/4" long
22.	173/04	1/4" B.S.F. Hexagon Nut
23.	161X106A	Operating Lever
24.	182/0516	5/16" B.S.F. Socket Head Set Screw Taper Point 1" long
25.	173/05	5/16" B.S.F. Hexagon Nut

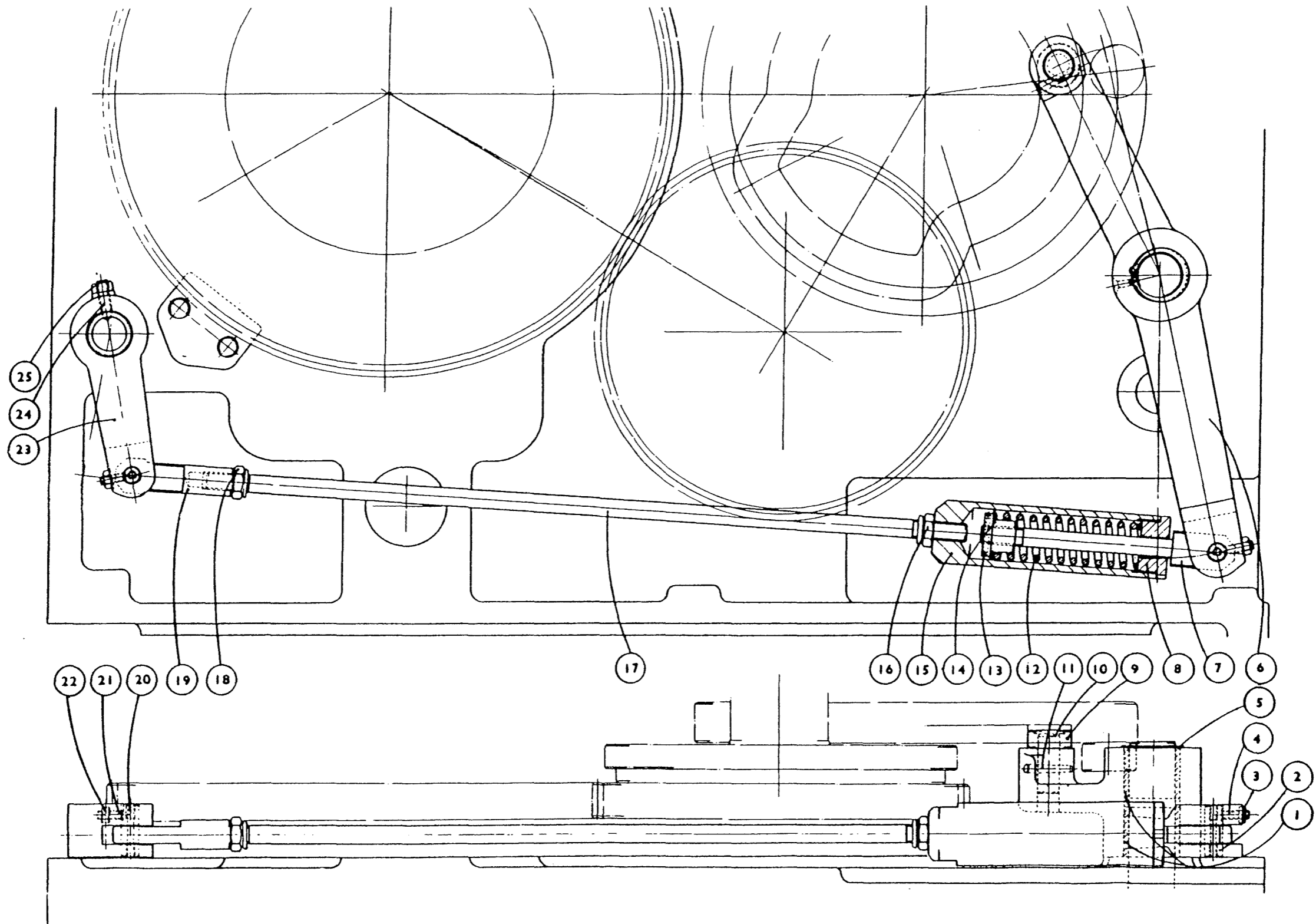

161 Z 1 DRUM LOCKING OPERATION

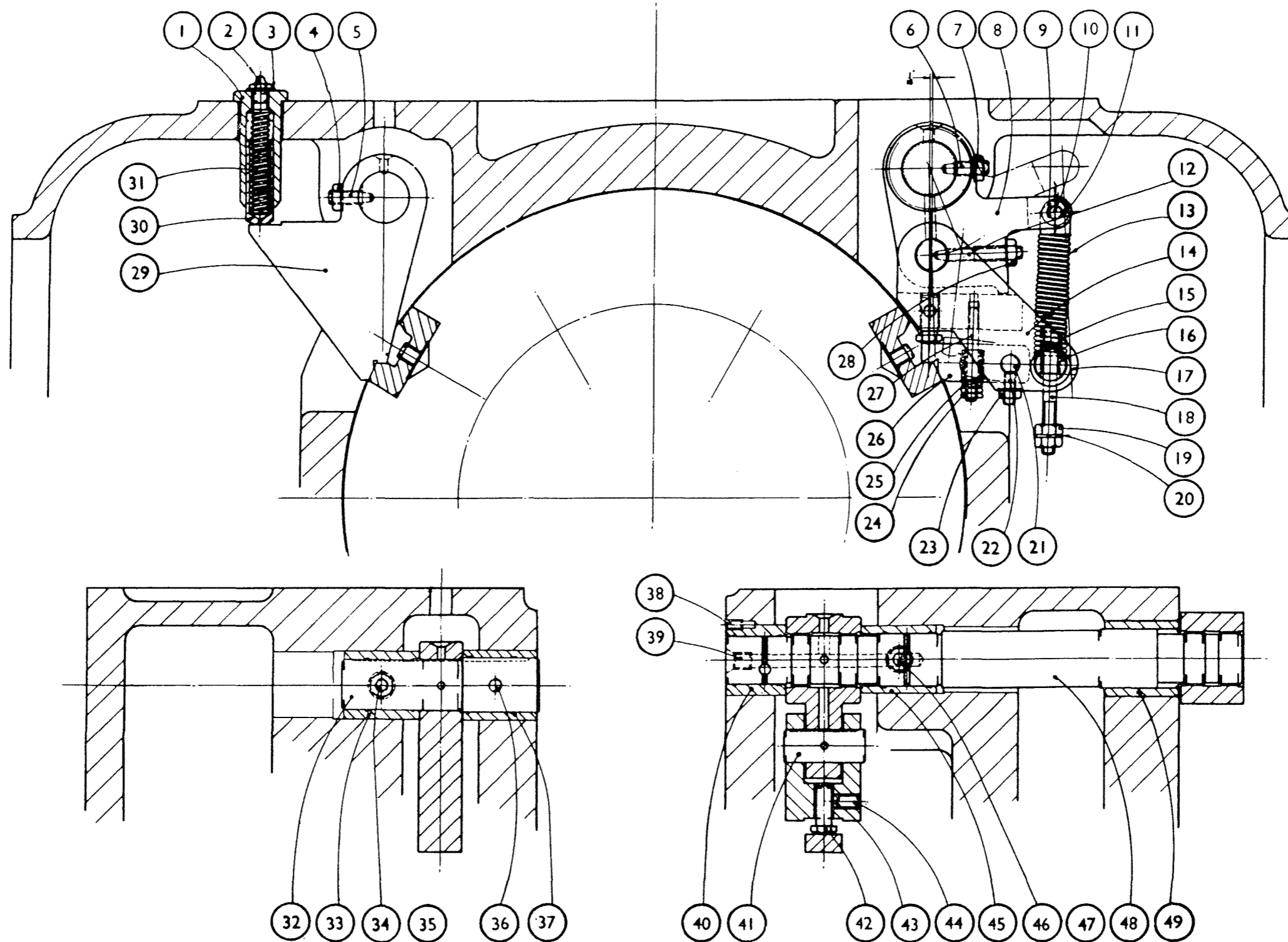

Drq No.163Z541 ----- Swarf Conveyor Unit and Chutes

1.	167/0408	1/4" B.S.F. Hexagon Set Screw x 1/2" long
2.	563V151	Fender
3.	563Y158A	Cover for Drive Tube
4.	155/0512	5/16" B.S.F. Socket Head Cap Screw 3/4" long
5.	130/05	5/16" Plain Washer
6.	163Y135G	Swarf Chute, Rear
7.	164/0508	Round Head Screw 5/16" B.S.F. 1/2" long
8.	163V155B	Tray Weir
9.	169Z134A	Swarf Basket
10.	163Y136A	Trough Cover
11.	203/04	Self-locking Nut, 1/4" B.S.F.
12.	188/0412	Square Head Set Screw, 1/4" B.S.F. x 3/4" long
13.	110/0076	Green Earth Wire Type T 3' long
14.	347/1035	5/8" dia. Conduit 35" long
15.	324 CP	Martin & Lunel 90 deg. rubber Plug
16.	271X587	Conduit Adaptor for Plug and Socket
17.	15041690	16mm - 5/8" 90 deg. Conduit Connector
18.	110309	16mm Dowty Seal.
19.	164/0508	5/16" B.S.F. Round Head Screw 1/2" long
20.	163V152A	Drum Housing Plate
21.	163Y134G	Swarf Chute - Front
22.	164/0508	5/16" B.S.F. Round Head Screw 1/2" long
23.	163Z133D	Swarf Chute
24.	15042091	20mm - 5/8" 90 deg. Conduit Connector
25.	110312	20mm Dowty Seal
26.	563X639	Conduit Adaptor
31.	165/210	2BA Round Head Screw 5/8" long
32.	150512	3/4" dia. Cable Clip
33.	163V108	Support Plate
34.	167/0612	3/8" B.S.F. Hexagon Head Set Screw 3/4" Long
35.		3/8" dia. Black Washer

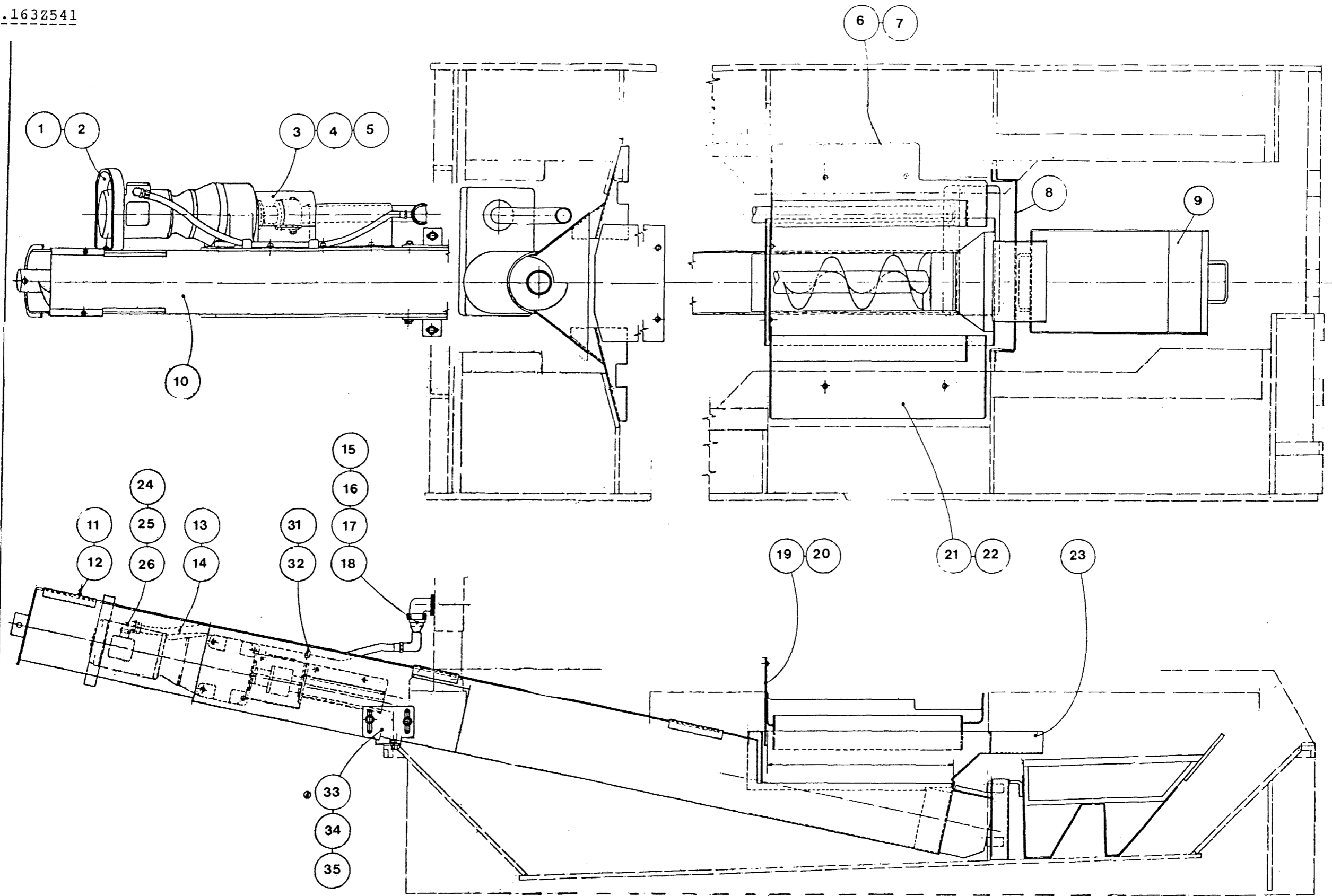

FIRST USED ON
LAST USED ON
SUPERSEDED
SUPERSEDED BY
ALTERATIONS
1 100A C10 20 11-57
2 100A C10 20 11-57

1/8" & 3/16" LIMIT HOLES TO B.S. 1564:1941
 REMOVS ALL SHARP CORNERS UNLESS OTHERWISE STATED
 TOLERANCE ON MACHINING DIMENSIONS ± .004" UNLESS OTHERWISE STATED
 AMERICAN PROJECTION
 P - ROUGH MACHINING
 PV - FINISH MACHINING
 PTV - TURNED ON
 EQUIVALENT
 RAW MATERIAL No.

WICKMAN AUTOMATIC LATHES LTD.
 COVENTRY ENGLAND.

COPYRIGHT © THIS DRAWING AND DESIGN IS THE PROPERTY OF WICKMAN AUTOMATIC LATHES LTD., COVENTRY, ENGLAND AND IS CONFIDENTIAL. IT MUST NOT BE LOANED, COPIED OR OTHERWISE COMMUNICATED TO A THIRD PARTY WITHOUT PERMISSION AND IS SUBJECT TO RECALL AT ANY TIME.

DESCRIPTION
ARRANGEMENT OF CONVEYOR UNIT & CHUTES (FABRICATED BASE M/C)

SCALE	1/2
DRAWN	SW
CHECKED	SW
TRACED	
TELESCOPED	
CHECKED	
MATERIAL	163 157

NO. OFF	163	SECTION	1-6	MACHINE	163 Z 34
DATE					112

Drg No.563Z1E ----- Swarf Conveyor Unit

1.	FX7790	Container for Shear Pins.
2.	165/403	4BA Round Head Screw 3/16" long
3.	No.252	3/4" dia. Spring Clip
4.	182/0412	1/4" B.S.F. Socket Set Screw (Taper Point) 3/4" long
5.	122/0816	Key 1/4" x 3/16" x 1" long
6.	179/206	2BA Socket Set Screw 3/8" long
7.	563X107D	Driving Coupling
8.	355/315	Retaining Ring 80mm
9.	124/0544	5/32" Silver Steel Pin
10.	127/0607	3/32" dia. Spliy Pin 7.8" long
11.	173/06	3/8" B.S.F. Hexagon Nut
12.	235/24346	Oil Seal 1.1/2" x 2.1/8" x 1/2"
13.	236/242820	Oil Retaining Bush 1.1/4" x 1.3/4" x 1.1/4"
14.	563X149	Pinion 16T
15.	182/0408	1/4" B.S.F. Socket Set Screw (Taper Point) 1/2" long
16.	563X119	Drive Pin - Input
17.	563X114	Piston Ring Seal
18.	563X162	Spacer
19.	130/05	5/16" dia. Plain Washer
20.	170/0516	5/16" B.S.F. Hexagon Head Bolt 1" long
21.	563X144A	Instruction Plate
22.	173/04L	1/4" B.S.F. Hexagon Nut
23.		Plate
24.	165/403	4BA Round Head Screw 3/16" long
25.	563X126B	Drive Sleeve
26.	563X145A	Drive Pin - Coupling
27.	563X116A	Vent Pipe
28.	154/2	2BA Spring Washer
29.	156/208	2BA Socket Head Cap Screw 1/2" long
30.	563X111	End Plate
31.	563X113	Sprocket Shaft
32.	122/1020T	Key 5/16" x 7/32" x 1.1/4" long
33.	236/202420	Oil Retaining Bush 1.1/4" x 1.1/2" x 1.1/4" long
34.	129/24	1.3/4" dia. Welch Plug
35.	563X117	Cap
36.	563Y104	Cover for Housing
37.	154/05	5/16" dia. Spring Washer
38.	155/0516	5/16" B.S.F. Socket Head Cap Screw 1" long
39.	563Y105	Gasket
40.	165/403	4BA Round Head Screw
41.	563X154	Oiling Plate
42.	154/2	2BA Spring Washer
43.	156/208	2BA Socket Head Cap Screw 1/2" long
44.	165/206	2BA Round Head Screw
45.	236/202420	Oil Retaining Bush 1.1/4" x 1.1/2" x 1.1/2" long
46.	182/0416	1/4" B.S.F. Socket Set Screw (Taper Point) 1" long
47.	563X150	Chain Wheel 29T
48.	122/1020T	Key 5/16" x 7/32" x 1.1/4" long
49.	563X113	Sprocket Shaft
50.	236/242820	Oil Retaining Bush 1.1/4" x 1.3/4" x 1.1/4"
51.	563Z101A	Drive Housing
52.	235/24346	Oil Seal 1.1/2" x 2.1/8" x 1/2"
53.	154/06	3/8" dia. Spring Washer
54.	155/0616	3/8" B.S.F. Socket Head Cap Screw 1" long
55.	563/111	End Plate
56.	563/114	Piston Ring Seal
57.	173/06	3/8" B.S.F. Hexagon Nut
58.	563X118	Drive Pin - Screw
59.	563X120	Drive Pin - Output
60.	167/0408	1/4" B.S.F. Hexagon Head Set Screw 1/2" long
61.	127/0607	3/32" dia. Split Pin 7/8" long
62.	173.06	3/8" B.S.F. Hexagon Nut

- | | | |
|-----|------------|--|
| 63. | 127/0607 | 3/32" dia. Split Pin 7.8" long |
| 64. | 563V146B | Cover Plate |
| 65. | 563X115 | Coupling - Driven |
| 66. | 167/0612 | 3/8" B.S.F. Hexagon Head Set Screw 3/4" long |
| 67. | - | 3/8" Large Black Washer |
| 68. | 163X108 | Support Strip |
| 69. | 114046 | Chain 1/2" Pitch .335 Roller 53 Pitches - Duplex |
| 70. | GF FIG 860 | 3/8" B.S.P. Pipe Clip |
| 71. | GF FIG 292 | 1/2" B.S.P. Hexagon Pipe Plug |
| 72. | - | 1/2" B.S.P. 90 deg. Elbow |

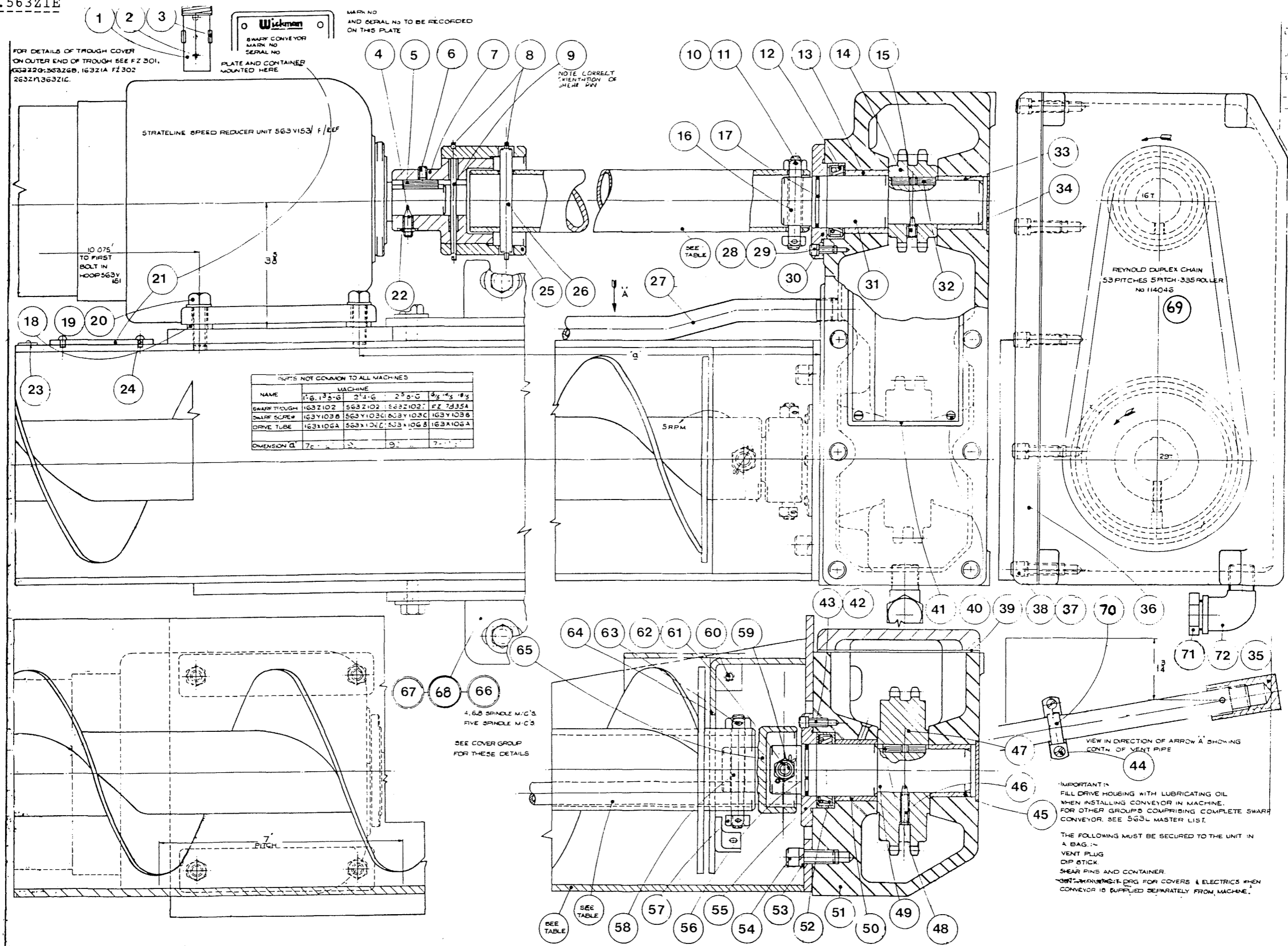

USED ON BATCH
 SUPERVISOR
 563Z1E
 SUPPLIED BY
 ALTERATIONS
 563Z1E
 563Z1E
 563Z1E

Wickman MACHINE TOOL DIVISION
 COVENTRY - ENGLAND

COPYRIGHT

DESCRIPTION
 DETAIL ARRANGEMENT OF CONVEYOR UNIT MARK

563 Z 1 E

Drq No.	164Z1C	Splash Guards
1.	164Y103B	Lower Splash Guard
2.	164Y126B	Splash Guard Rear
3.	164V124	Drum Housing Side Guard
4.	164/0406	Slotted Round Head Screw 1/4" BSF x 3.8" long
5.	164V129	Top Splash Guard Rear 1"-6 only
6.	136V125	Top Splash Guard Rear 1" - 6S only
7.	164Z102C	Rear Splash Guard
8.	164/0508	Round Head Set Screw 5/16" BSF x 1/2" long
9.	164Z101C	Front Splash Guard
10.	164V128	Top Splash Guard Front 1" - 6 only
11.	136V125	Top Splash Guard Front 1" - 6S
12.	164/0406	Slotted Round Head Screw 1/4" BSF x 3/8" long
13.	164X112A	Splash Guard Rail
14.	167/0520	Hex. Head Set Screw 5/16" BSF x 1.1/4" long
15.	130/05	Plain Washer for 5/16" diameter
16.	136X121	Support Stud
17.		Perspex sheet 21" wide x 14.7/8" x 1/8" thick
18.		Nebar Packing 5/8" wide x 1/8" thick
19.	160/0508	Socket Round Head Screw 5/17" BSF x 1/2" long
20.	164V127B	Splash Guard Front
21.	164/0406	Slotted Round Head screw 1/4" BSF x 3/8" long
22.	164V123	Drum Housing Side Guard
23.	164Y103B	Lower Splash Guard
24.	164X117A	Lower Splash Guard Support
25.	155/0520	Socket Head Cap Screw 5/16" BSF x 1.1/4" long
26.	164Y120	Work Basket
27.	Purefoy 200-80	Shoulder Screw 3/8" x 1.1/2" long
28.	130/05	Plain Washer for 5/16" diameter
29.	167/0520	Hex. Head Set Screw 5/16" BSF x 1.1/4" long
30.	136X120	Support Stud
31.	264X113	Spacing Washer
32.	130/05	Plain Washer for 5/16" diameter
33.	258/8	Light Ball Journal 8.22 7mm
34.	130/05	Plain Washer for 5/16" diameter
35.	167/0512	Hex. Head Set Screw 5/16" BSF x 3/4" long
36.	130/05	Plain Washer for 5/16" diameter
37.	203/05L	Locknut - Simmonds 5/16" BSF
38.	155/0516	Socket Head Cap Screw 5/16" BSF x 1" long
39.	258/8	Light Ball Journal 8/22 7mm

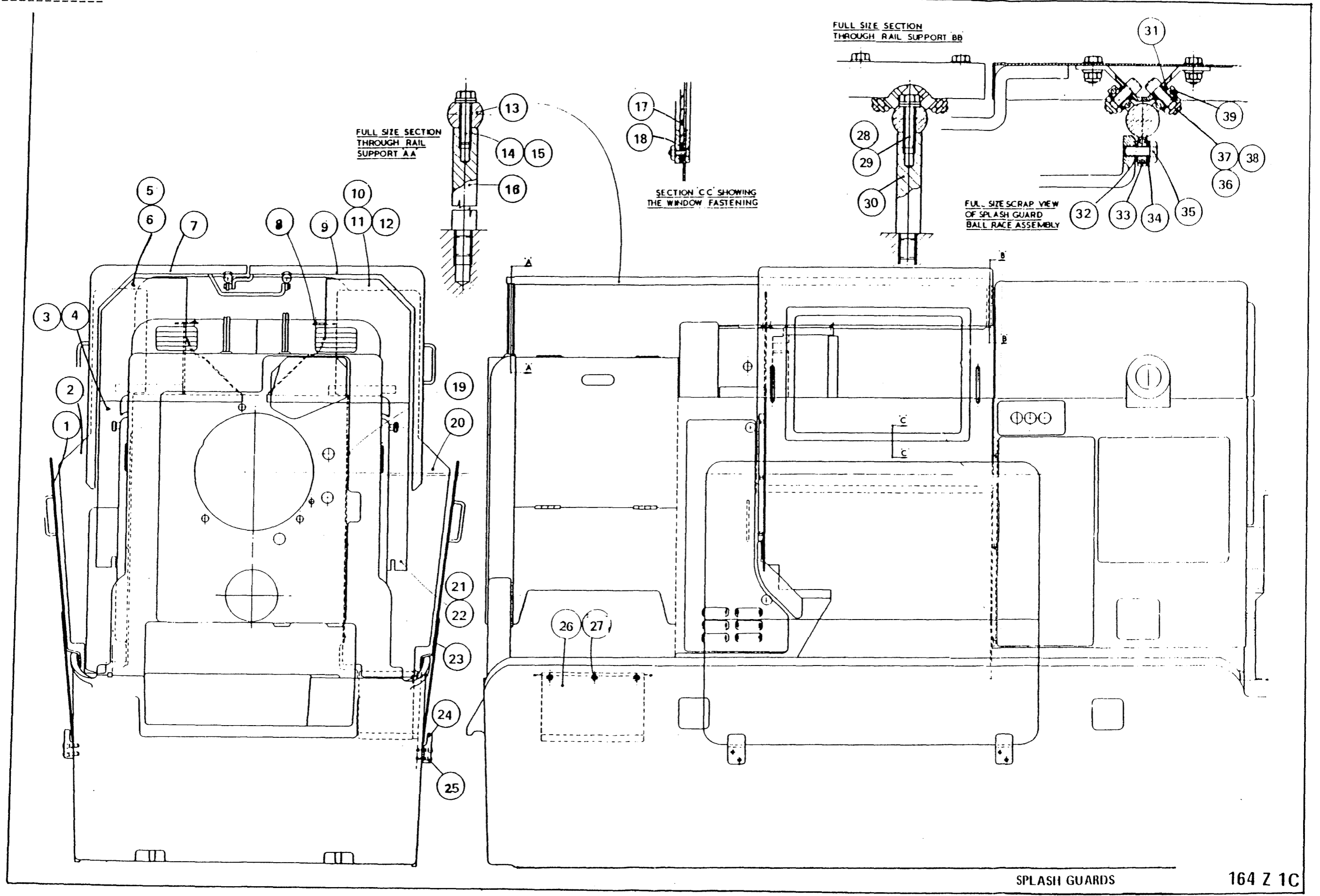

Drg No. 164Z71 Front Elevation of Enclosed Spalsh Guards

1. 164X653 Splash Plate
2. 155/0620 3/8" x 1.1/4" long B.S.F. Cap Head Screws & 154/06 Spring Washer
3. 164Z646 Sliding Guard
4. 164Y540 Beam Angle (Rear)
5. 164X661 Spacer
6. 164Y541A Cowl End Cover
7. 164Z642 Cowl
8. 164X660 Bracket
9. 164X658 Spacer
10. 155/0620 rews 3/8" B.S.F. x 1.1/4" long
11. 154/06 Spring Washer
12. 155/0410 Cap Head Screws 1/4" B.S.F. x 5/8" long
13. 130/04 Washer
14. 173/04 Hexagon Nut
15. 164Y651 Loose Splash Cover (Front)
16. 164Y652 Loose Splash Cover (Rear)
17. 164Z645 End Support Bracket
18. 155/0836 Cap Head Screws 1/2" B.S.F. x 2.1/4"
19. 154/08 Spring Washer

Drg No. 164Z71

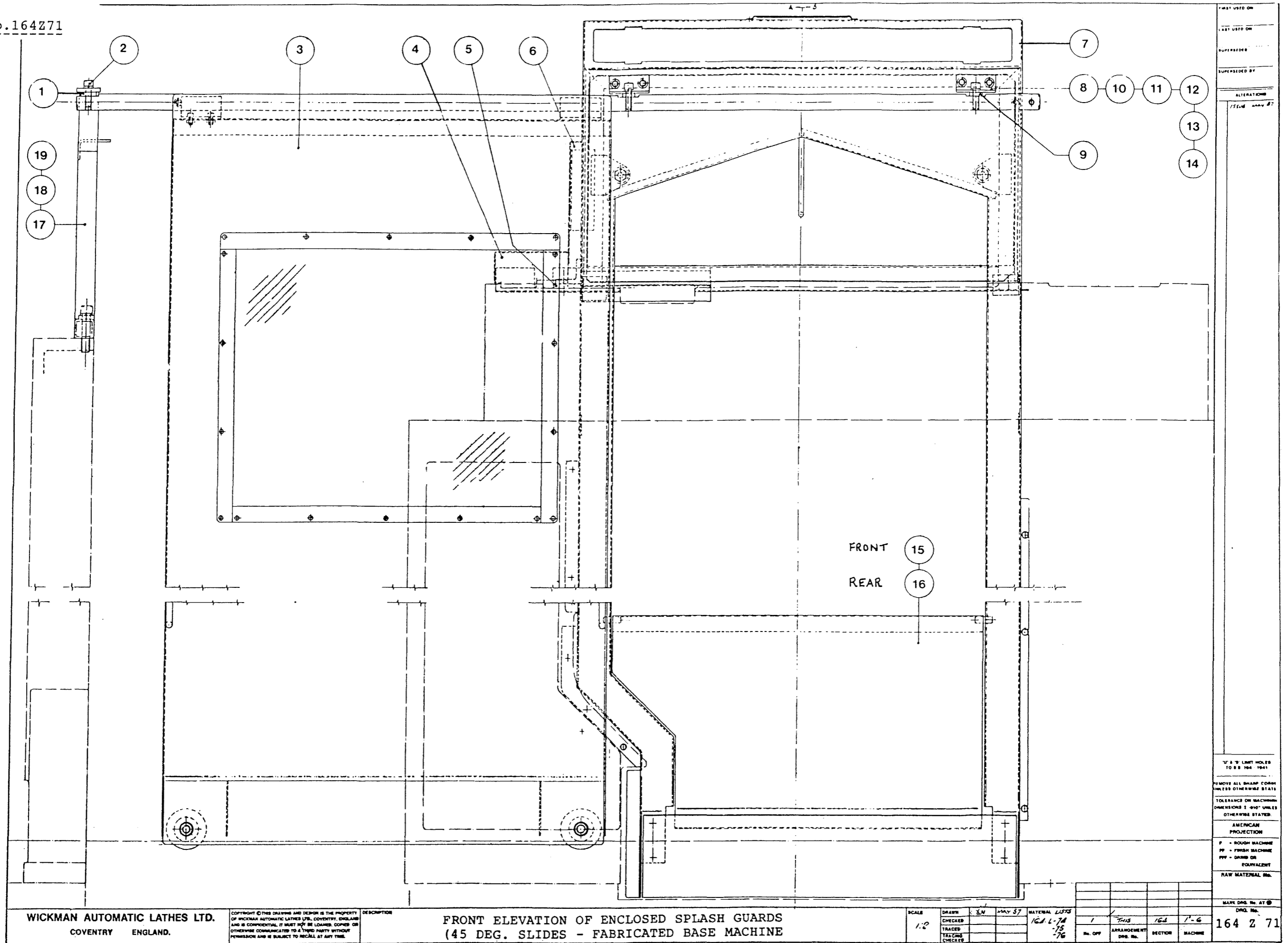

FIRST USED ON	
LAST USED ON	
SUPERSEDED BY	
SUPERSEDED BY	
ALTERATIONS	
ISSUE NO. & DATE	

1	FRONT	16	REAR
2		17	
3		18	
4		19	
5			
6			
7			
8			
9			
10			
11			
12			
13			
14			

1	FRONT	16	REAR
2		17	
3		18	
4		19	
5			
6			
7			
8			
9			
10			
11			
12			
13			
14			

SCALE	1:2
DRAWN	LN MAY 57
CHECKED	
TRACED	
TRACED	
CHECKED	

MATERIAL LIST	
164 Z 71	
75	
76	

1	FRONT	16	REAR
2		17	
3		18	
4		19	
5			
6			
7			
8			
9			
10			
11			
12			
13			
14			

164 Z 71

Drg No. 164271

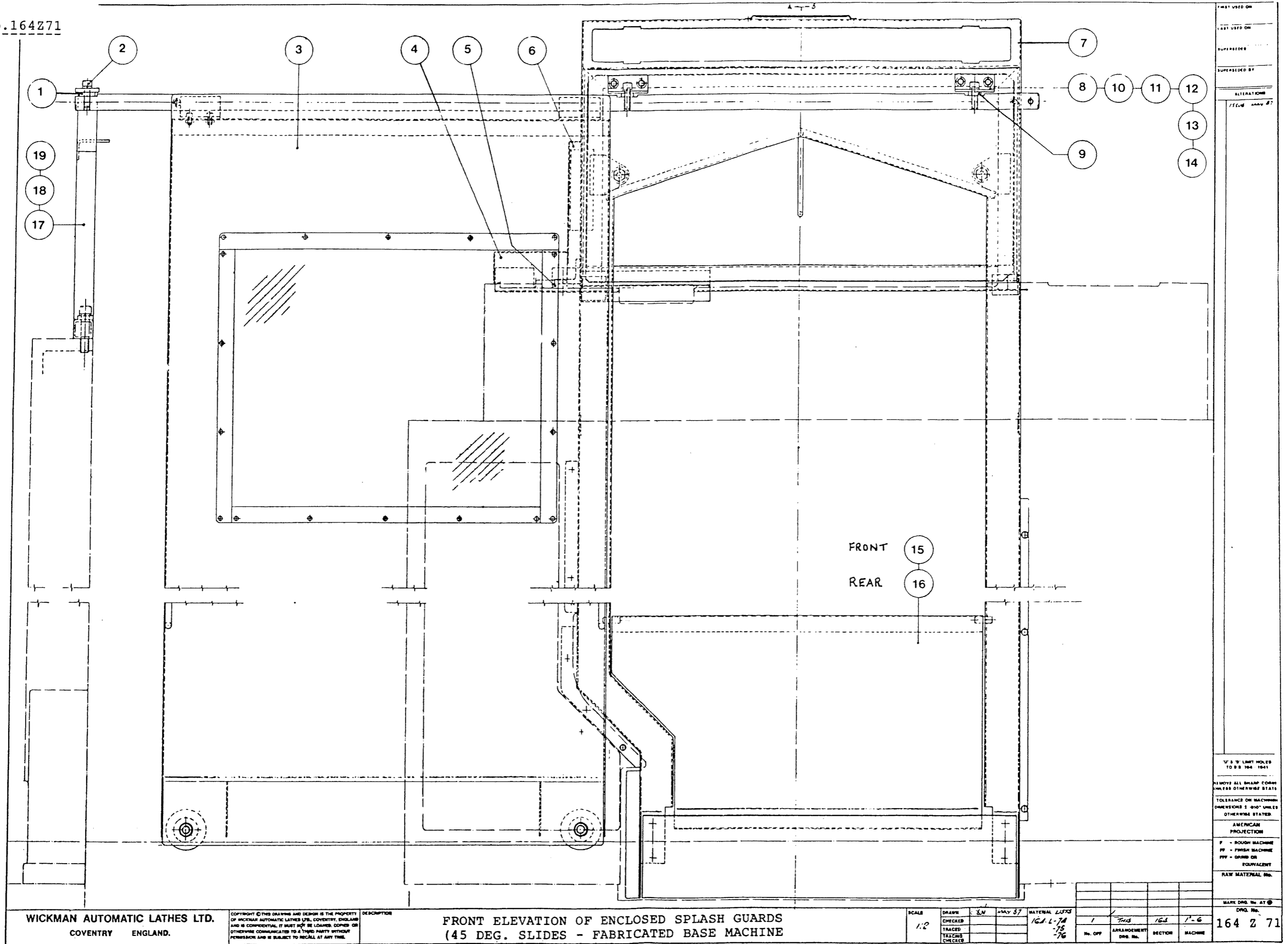

FIRST USED ON	
LAST USED ON	
SUPERSEDED	
SUPERSEDED BY	
ALTERATIONS	
FILED	

17 & 18 LIMIT HOLES TO B B 194 1941
REMOVE ALL SHARP CORNERS UNLESS OTHERWISE STATED
TOLERANCE ON MACHINING DIMENSIONS ± .010" UNLESS OTHERWISE STATED
AMERICAN PROJECTION
R - ROUGH MACHINE
FF - FINISH MACHINE
FFV - GRIND OR EQUIVALENT
RAW MATERIAL NO.
MAKE DRG. IN AT
DRG. No.
164 2 71

SCALE	1:2
DRAWN	JUN MAY 87
CHECKED	
TRACED	
CHECKED	
MATERIAL LIST	164 L-74 -75 -76
No. OFF	1
ARRANGEMENT	THIS
DRG. No.	164
SECTION	1-6
MACHINE	

WICKMAN AUTOMATIC LATHES LTD.
COVENTRY ENGLAND.

COPYRIGHT © THIS DRAWING AND DESIGN IS THE PROPERTY OF WICKMAN AUTOMATIC LATHES LTD., COVENTRY, ENGLAND AND IS CONFIDENTIAL. IT MUST NOT BE LOANED, COPIED OR OTHERWISE COMMUNICATED TO A THIRD PARTY WITHOUT PERMISSION AND IS SUBJECT TO RECALL AT ANY TIME.

FRONT ELEVATION OF ENCLOSED SPLASH GUARDS
(45 DEG. SLIDES - FABRICATED BASE MACHINE)

Drg No. 164Z72 Section 'A-A' of Enclosed Splash Guards

1.	164Y644	Beam Top Cover (Rear)
2.	164Z645	End Support Bracket
3.	164/0406	Round Head Screws 1/4" B.S.F. x 3/8" long
4.	130/04	Washer
5.	165/208	Round Head Screws 2BA x 1/2" long
6.	130/03	Washer
7.	164Y544	Slide Cover (Rear)
8.	165/210	Round Head Screws 2BA x 5/8" long
9.	164Y540	Beam Angle (Rear)
10.	155/0414	Cap Head Screws 1/4" B.S.F. x 5/8" long
11.	130/04	Washer
12.	164Y539	Beam Angle (Front)
13.	155/0414	Cap Head Screws 1/4" B.S.F. x 5/8" long
14.	130/04	Washer
15.	164Y543	Slide Cover (Front)
16.	165/210	Round Head Screws 2BA x 5/8" long
17.	164Z647	Front Blinker (Drum HSG)
18.	164Y653	Splash Plate
19.	167/0508	Hexagon Head Screw 5/16" B.S.F. x 1/2" long
20.	130/05	Washer
21.	173/05	Hexagon Nut 5/16" B.S.F.
22.	164Y643	Slide Cover Front
23.	422X130A	Keep Screw
24.	130/04	Washer
25.	173/04	Hexagon Nut 1/4" B.S.F.
26.	164/0406	Round Head Screw 1/4" B.S.F. x 3/8" long
27.	164X659	Guide
28.	155/0410	Cap Head Screw 1/4" B.S.F. x 5/8" long
29.	130/04	Washer
30.	173/04	Hex. Nut 1/4" B.S.F.
31.	164V654	Guide Bar
32.	130/08	Washer
33.	167/0508	Hexagon Head Screws 5/16" B.S.F. x 1/2" long
34.	173/08	Hexagon Nut 1/2" B.S.F.
35.	11/03/07	Dowty Seal

LAST USED ON
SUPERSEDED
SUPERSEDED BY
ALTERATIONS
A 120 & 639
B 1001645 11 JUN 87
C 1001655 11 JUN 87
D 1001661 24 JUL 89

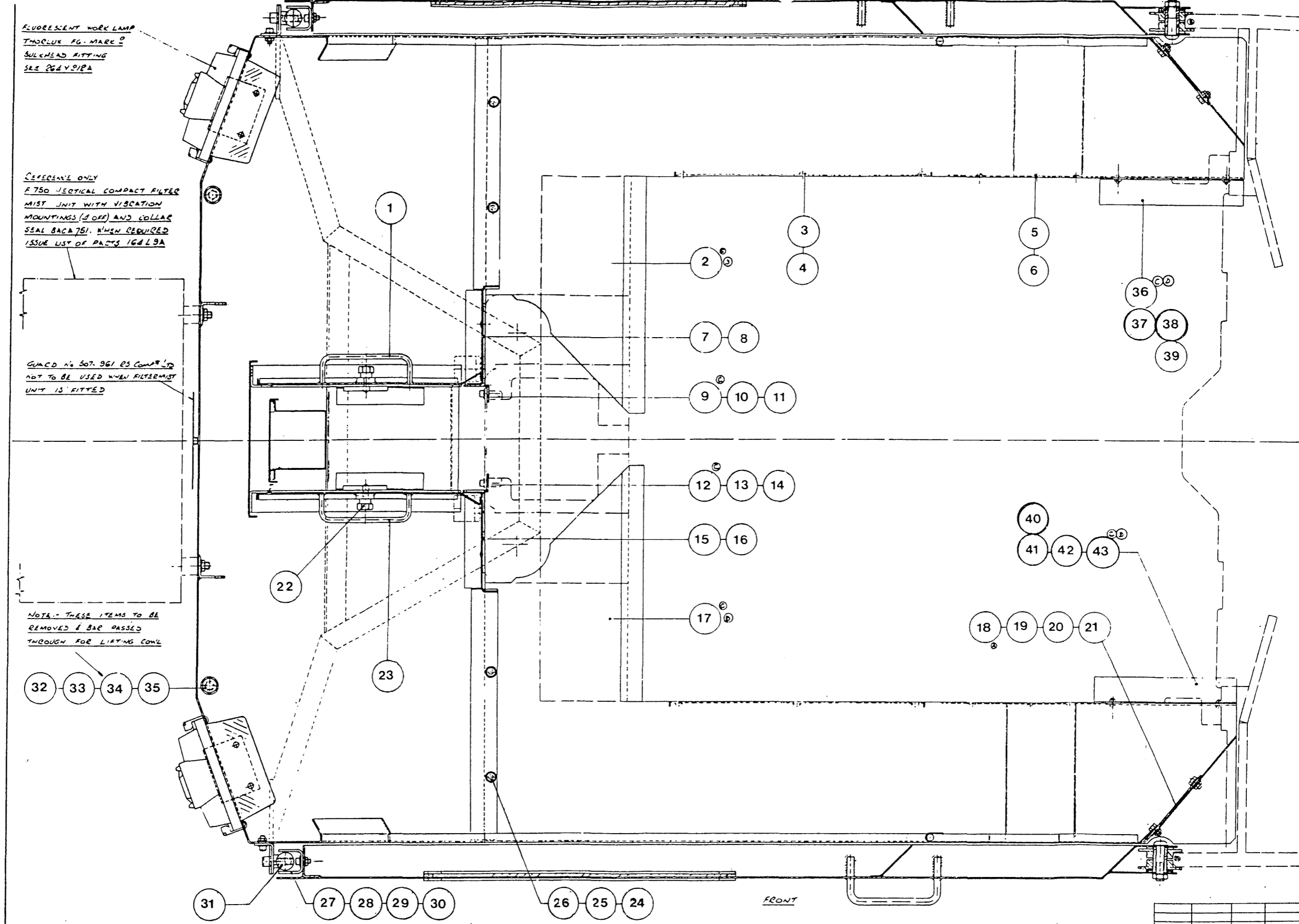

1" & 3" LMT HOLES TO B.B. 1641

REMOVE ALL SHARP CORNERS UNLESS OTHERWISE STATED

TOLERANCE ON MACHINING DIMENSIONS ± .010 UNLESS OTHERWISE STATED

AMERICAN PROJECTION

F = ROUGH MACHINE
 PF = FINISH MACHINE
 PFF = GAUGE OR EQUIVALENT
 RAW MATERIAL No.

WICKMAN AUTOMATIC LATHES LTD. COVENTRY ENGLAND.	COPYRIGHT © THIS DRAWING AND DESIGN IS THE PROPERTY OF WICKMAN AUTOMATIC LATHES LTD. COVENTRY, ENGLAND AND IS CONFIDENTIAL. IT MUST NOT BE LOANED, COPIED OR OTHERWISE COMMUNICATED TO A THIRD PARTY WITHOUT PERMISSION AND IS SUBJECT TO RECALL AT ANY TIME.	DESCRIPTION SECTION A-A OF ENCLOSED SPLASH GUARDS (45° SLIDES - FABRICATED BASE MACHINE)	SCALE	1:2	DRAWN CHECKED TRACED CHECKED	DATE 11/27	MATERIAL LISTS 164L 74 L 75 L 76	No. OFF 1	ARRANGEMENT 1-15	SECTION 164	MACHINE 2-6	MARK DRG. No. AT © DRG. No. 164 Z-72

Drg No. 164Z73 Section 'B-B' of Enclosed Spalsh Guards

1. 160/0508 Round Head Cap Screws 5/16" B.S.F. x 1/2" long
2. 130/05 Washer
3. 164Z650 Rear Blinker (Drive HSG)
4. 167/0408 Hexagon Head Screws 1/4" B.S.F. x 1/2" long
5. 130/04 Washer
6. 173/04 exagon Nut 1/4" B.S.F.
7. 164X664 Cable Plate
8. 164Z649 Front Blinker (Drive HSG)
9. 130/05 Washer
10. 160/0508 Round Head cap Screws 5/16" B.S.F. x 1/2" long
11. 0605/12 Shake Proof Washer
12. 05/01/62 Hexagon Nut
13. 04/21/1250 Round Head Screws
14. 164X657 Spacer
15. 164X656 Roller Spindle
16. 164X665 Splash Guard Roller

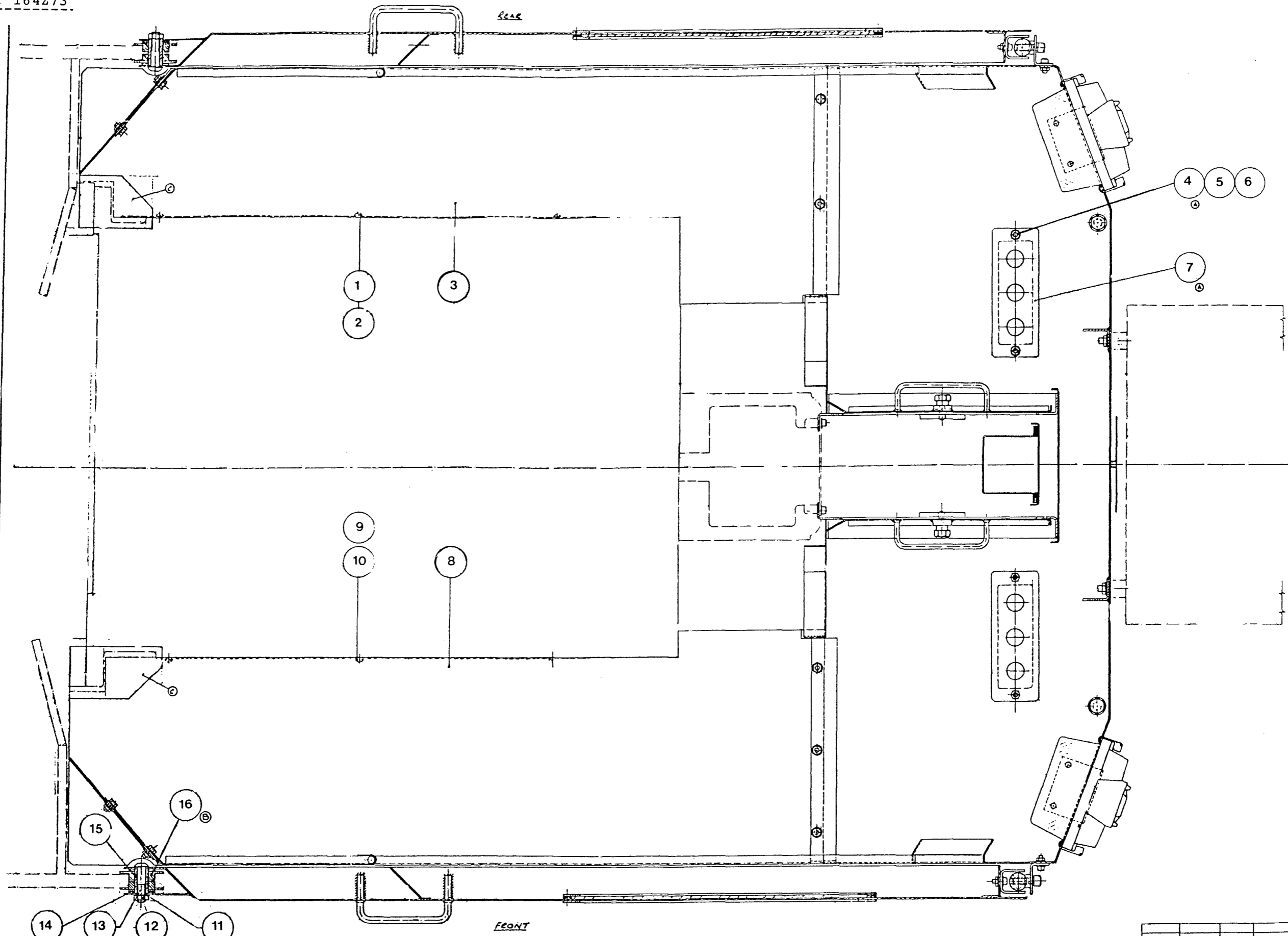

FIRST USED ON
LAST USED ON
SUPERSEDES
SUPERSEDED BY

ALTERATIONS	
A	ISSUE FOR A 648 24 JUN 85
B	100A 645 184 JUN 85
C	100A 647 244 AUG 85

1/2" & 3/4" LIMIT HOLES TO B.S. 164 : 1941

REMOVE ALL SHARP CORNER UNLESS OTHERWISE STATED

TOLERANCE ON MACHINING DIMENSIONS ± .015" UNLESS OTHERWISE STATED.

AMERICAN PROJECTION

F - ROUGH MACHINING
 FV - FINISH MACHINING
 FFF - BARRIS OR EQUIVALENT

RAW MATERIAL No.

WICKMAN AUTOMATIC LATHES LTD.
 COVENTRY ENGLAND.

COPYRIGHT © THIS DRAWING AND DESIGN IS THE PROPERTY OF WICKMAN AUTOMATIC LATHES LTD., COVENTRY, ENGLAND AND IS CONFIDENTIAL. IT MUST NOT BE LOANED, COPIED OR OTHERWISE COMMUNICATED TO A THIRD PARTY WITHOUT PERMISSION AND IS SUBJECT TO RECALL AT ANY TIME.

DESCRIPTION
**SECTION BB OF ENCLOSED SPLASH GUARDS
 (45 deg. SLIDES - FABRICATED BASE M/C)**

SCALE	1:2
DRAWN	CLJ
CHECKED	
TRACED	
TRACES	
CHECKED	
MATERIAL LISTS	164 L 74 75 76

NO. OFF	1	THIS	164	1-6
ARRANGEMENT				
DWG. No.				
SECTION				
MACHINE				

WAVE DRG. No. 47
 DRG. No.
164 Z 73

Drg.No.164Z74 ----- Front Elevation of Enc. Splash Guards 30 deg Slides

1.	164X658	Spacer
2.	155/0620	3/8" BSF Socket Head Cap Screw x 1.1/4" long
3.	154/06	Washer
4.	164Z646	Sliding Guard
5.	164V557	Beam End Cover
6.	167/0816	1/2" BSF Hex Head Set Screw x 1" long
7.	154/08	Spring Steel Washer
8.	164V676	Cowl End Cover
9.	164Z666	Cowl
10.	164X660	Bracket
11.	155/0620	3/8" BSF Socket Head Cap Screw x 1.1/4" long
12.	154/06	Washer
13.	155/0410	1/4" BSF Socket Head Cap Screw x 5/8" long
14.	130/04	Washer
15.	173/04	1/4" BSF Hex Locknut
16.	164X658	Spacer
17.	14/14/04	Enots Bulkhead Connector
18.	164Y673	Loose Splash Cover (Front)
19.	164Y674	Loose Splash Cover (Rear)
20.	154/08	Washer
21.	155/0336	3/16" BSF Socket Head Cap Screw x 2.1/4" long
22.	164Z645	End Support Bracket

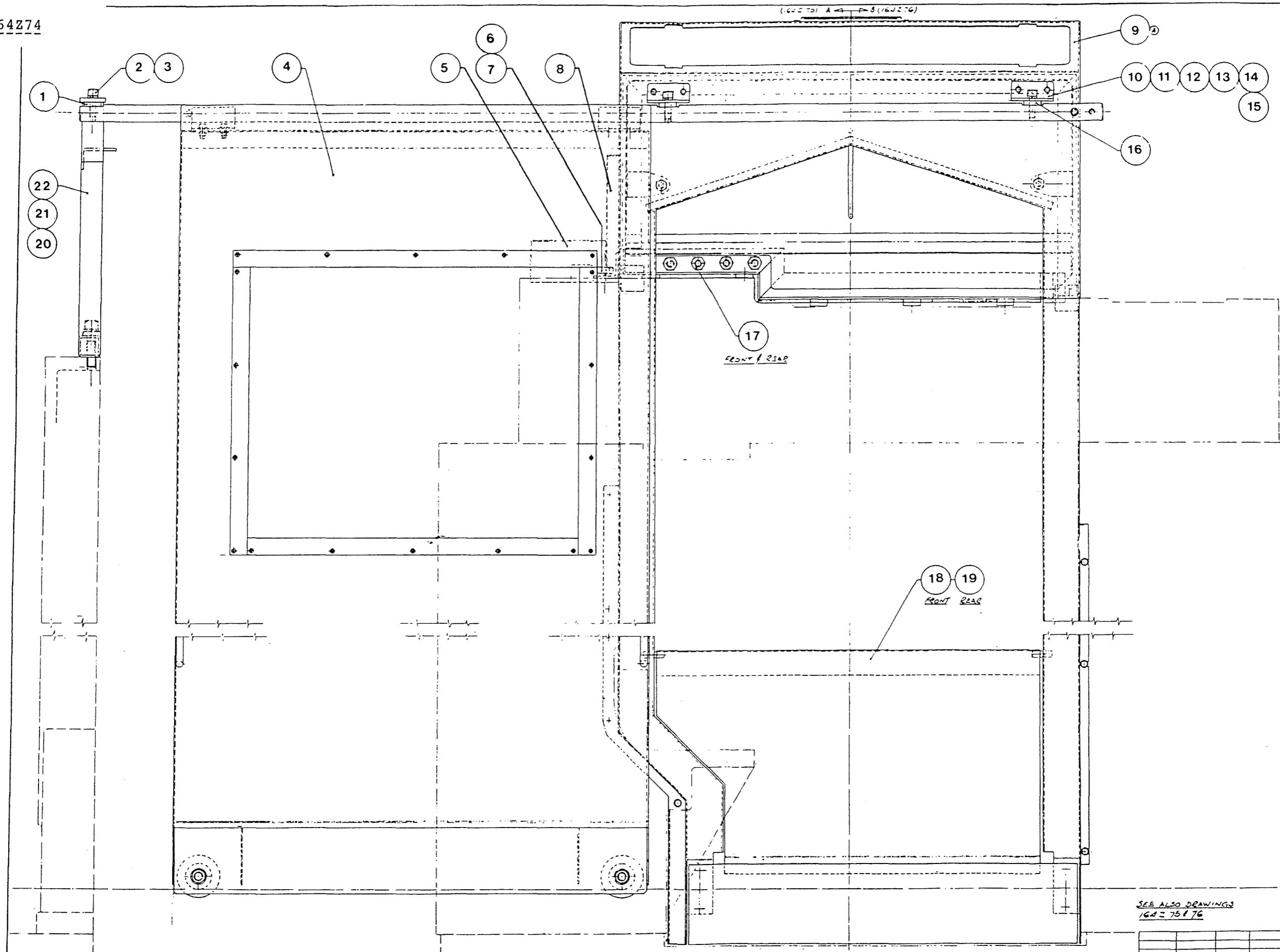

FIRST USED ON	
LAST USED ON	
SUPERSEDED	
SUPERSEDED BY	
ALTERATIONS	
A	ISSUE 100 A 660 24 6 3 89
V & S LIMIT HOLES TO BS 184 1941	
REMOVE ALL SHARP CORNERS UNLESS OTHERWISE STATED	
TOLERANCE ON MACHINING DIMENSIONS ± 0.10 UNLESS OTHERWISE STATED	
AMERICAN PROJECTION	
F - FINISH MACHINE FF - FINISH MACHINE FP - FINISH OR EQUIVALENT	
RAW MATERIAL No.	
MARK DNG. No. AT @	
DNG. No.	
164Z74	

WICKMAN AUTOMATIC LATHES LTD. COVENTRY ENGLAND.	COPYRIGHT © THIS DRAWING AND DESIGN IS THE PROPERTY OF WICKMAN AUTOMATIC LATHES LTD., COVENTRY, ENGLAND AND IS CONFIDENTIAL. IT MUST NOT BE LOANED, COPIED OR OTHERWISE COMMUNICATED TO A THIRD PARTY WITHOUT PERMISSION AND IS SUBJECT TO RECALL AT ANY TIME.	DESCRIPTION FRONT ELEVATION OF ENCLOSED SPLASH GUARDS (30 SLIDES - FABRICATED TRAY MACHINES)	SCALE	1:2	DRAWN	JW	31.08	MATERIAL LISTS	164L77		
			CHECKED							L78	
			TRACED								L79
			CHECKED								
			No. OFF	1	ARRANGEMENT	16d	SECTION	1.63	MACHINE		

Drg No.168Z1B Lubrication Pump

1. 168X111A Pump Gear
2. 168X138A Gear Pin
3. 154/04 1/4" Spring Washer
4. 155/0414 1/4" B.S.F. Socket Head Cap Screw 7/8" long
5. 168X103A Pump End Plate
6. 168Y101A Pump Body
7. 168X109A Pump Gear Shaft
8. Superfect No. 10016 Oil Seal 1/2" x 1" x 3/8"
9. 123/30 1/2" dia. Woodruff Key 1/8" wide
11. 218/19 Enots Tubing Nut 3/8" o/dia. Tube
12. 209/6 Enots Tubing Plug 3/8" o/dia. Tube

Spare Elements for Oil Filters:

a) 'Purolator' Scraper Type Filter:-

Filter Element No. MP9909

b) 'Micronic' filter:-

Filter Element No. MFF-377A Last used on Insp. No. 17042

Filter Element No. APF 873 First used on Insp. No. 17043

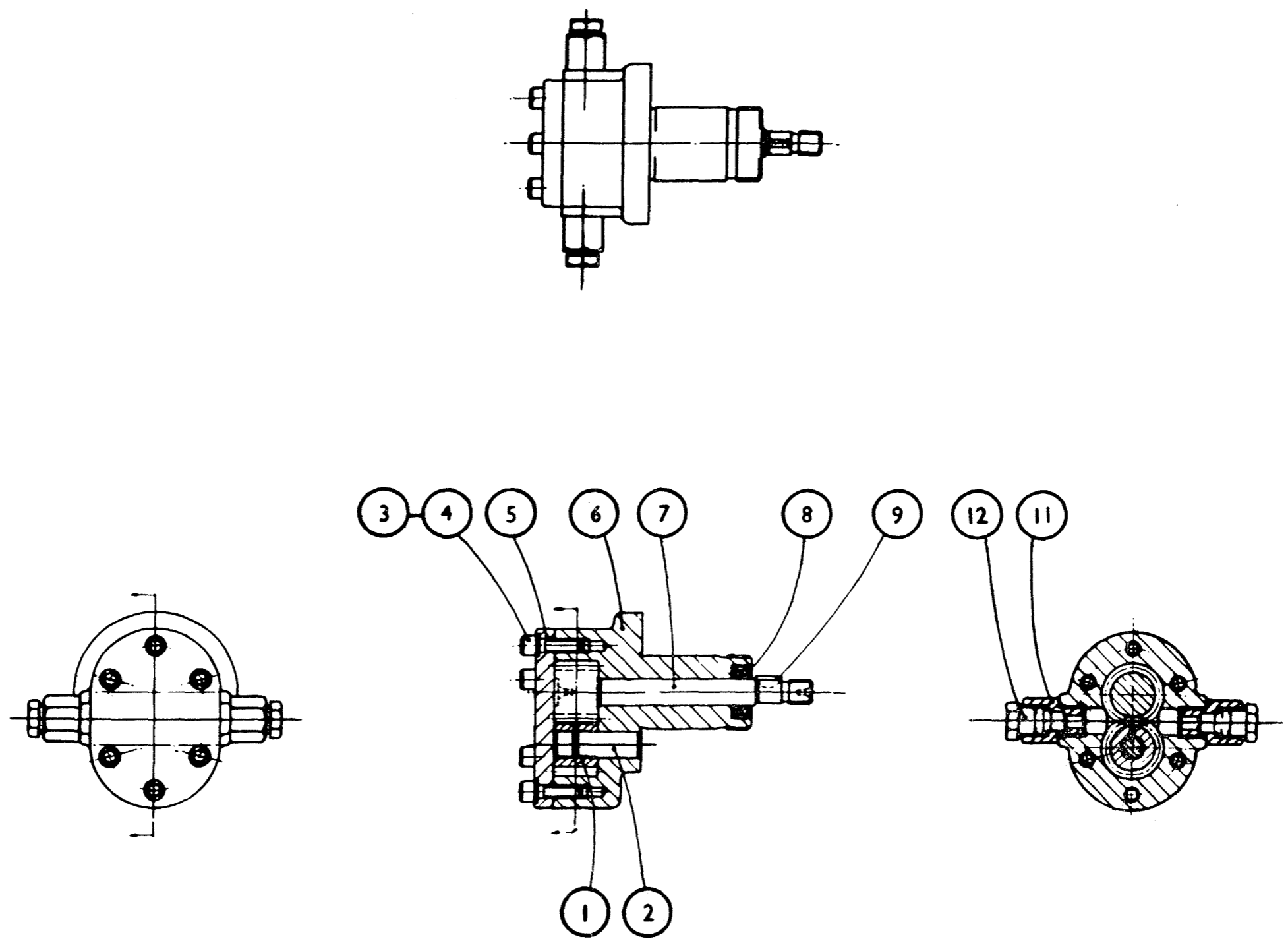

Drg No.169Z2C Coolant Pipes System

1.	155/0440	Socket Head Cap Screw 1/4 BSF x 2.1/2 long
2.	155/0408	Socket Head Cap Screw 1/4 BSF x 1/2 long
3.	14191108	Clips 1/2 BSP
4.	169X168	Pipe Support Bracket
5.	14203312	3/4 BSP Close Taper Nipple
6.	142015/63/B	Pipe 1/2 BSP x 2.1/2 long
7.	169X150	Drum Housing Pipe (Front)
8.	169X151	Drum Housing Pipe (Rear)
9.	14190108	1/2 BSP 90 Female Elbow
10.	142015/489/B	Pipe 1/2 BSP x 19.1/4" long
11.	169V167	Tray Strainer
12.	155/0412	Socket Head Cap Screw 1/4 BSF x 3/4" long
13.	169Y170/1	230/400 Volts, 50 Cycle
	169Y170/2	500 Volts, 50 Cycle
	169Y170/3	600 Volts, 60 Cycle
	169Y170/4	240/480 Volts, 60 Cycle
14.	169Y169	Pump Mounting Bracket
15.	155/0728	Socket Head Cap Screw 7/16 BSF x 1.3/4" long
16.	14191108	Clips 1/2 BSP
17.	156/208	Socket Head Cap Screw 2BA x 1/2" long
18.	14192043	1/2 BSP 3/8 BSP Hexagon Bush
19.	14.19.0908	1/2 BSP Equal Tee
20.	14190206	3/8 BSP x 90 M & F Elbow
21.	14190112	3/4 BSP 90 Female Elbow
22.	14190120	1.1/4 BSP 90 Female Elbow
23.	14190220	1.1/4 BSP 90 M & F Elbow
24.	169X138	Flexible Pipe
25.	14192120	1.1/4 BSP Socket
26.	4192220	1.1/4 BSP Backnut
27.	142032/254	1.1/4 BSP x 10" long
28.	14190652	1.1/4 x 1.1/4 x 3/4 BSP Tee
29.	142032/190/B	1.1/4 BSP x 7.1/2" long
30.	194/3	Socket Pipe Plug 3/8 BSP
31.	194/3	Socket Pipe Plug 3/8 BSP
32.	P211/T57	3/8 BSP M & F Tap
33.	142020/327/B	3/4 BSP x 12.7/8" long
34.	14192412	3/4 BSP Female Union (Straight)
35.	142020/32/B	3/4 BSP x 12 7./8" long
36.	14190212	3/4 BSP 90 M & F Elbow
37.		1/2 BSP x 1/2 BSP x 3/4 BSP Tee
38.	142032/1108/B	1.1/4 BSP x 43 5/8" long
39.	169X128	Cross Slide Pipe
40.	14190408	1/2 BSP x 45 Female Elbow
41.	14192420	1.1/4 BSP Female Union (Straight)
42.	14190120	1.1/4 BSP 90 Female Elbow
43.	142032/76/B	1.1/4 BSP x 3" long
44.	165/210	Round Head Screw 2BA x 5/8" long
45.	150514	Cable Clip 7/8"
46.	15021220	Conduit Locknut 20mm
47.	15042000	Straight Connector 20mm / 3/4"
48.	110312	20mm Dowty Seal
49.	15042090	90mm Connector 20mm / 3/4"
50.	347/1280	Flexible Conduit 3/4" x 80" long
51.	154/05	Spring Washer 5/16" dia.
52.	155/0528	Socket Head Cap Screw 5/16" BSF x 1.3/4" long
53.	155/0544	Socket Head Cap Screw 5/16" BSF x 2.3/4" long

54.	169Y115	Coolant Manifold (Rear)
55.	169X113A	Manifold Gasket (Rear)
56.	14190120	1.1/4 BSP 90 Female Elbow
57.	142032/184/B	1.1/4 BSP x 7.1/4" long
58.	142032/254/ C/75	1.1/4 BSP x 10" long
59.	169X146A	Sealing Washer
60.	194/6	Socket Pipe Plug 3/4 BSP
61.	142020/140/B	3/4 BSP x 5.1/2" long
62.	14190912	3/4 BSP Equal Tee
63.	142032/149/B	1.1/4 BSP x 5 7/8" long
64.	269V166	Pump Inlet
65.	155/0412	Socket Head Cap Screw 1/4 BSF X 3/4" long
66.	269Y165A	Coolant Strainer
67.	537X116	Plug
68.	169X111	Manifold Gasket (Front)
69.	169Y114	Coolant Manifold (Front)
70.	155/0536	Socket Head Cap Screw 5/16 BSF x 2.1/4" long
71.	155/0520	Socket Head Cap Screw 5/16 BSF x 1.1/4" long
72.	154/05	Spring Washer 5/16" dia.
73.	P211/T57	3/8 BSP M & F Tap

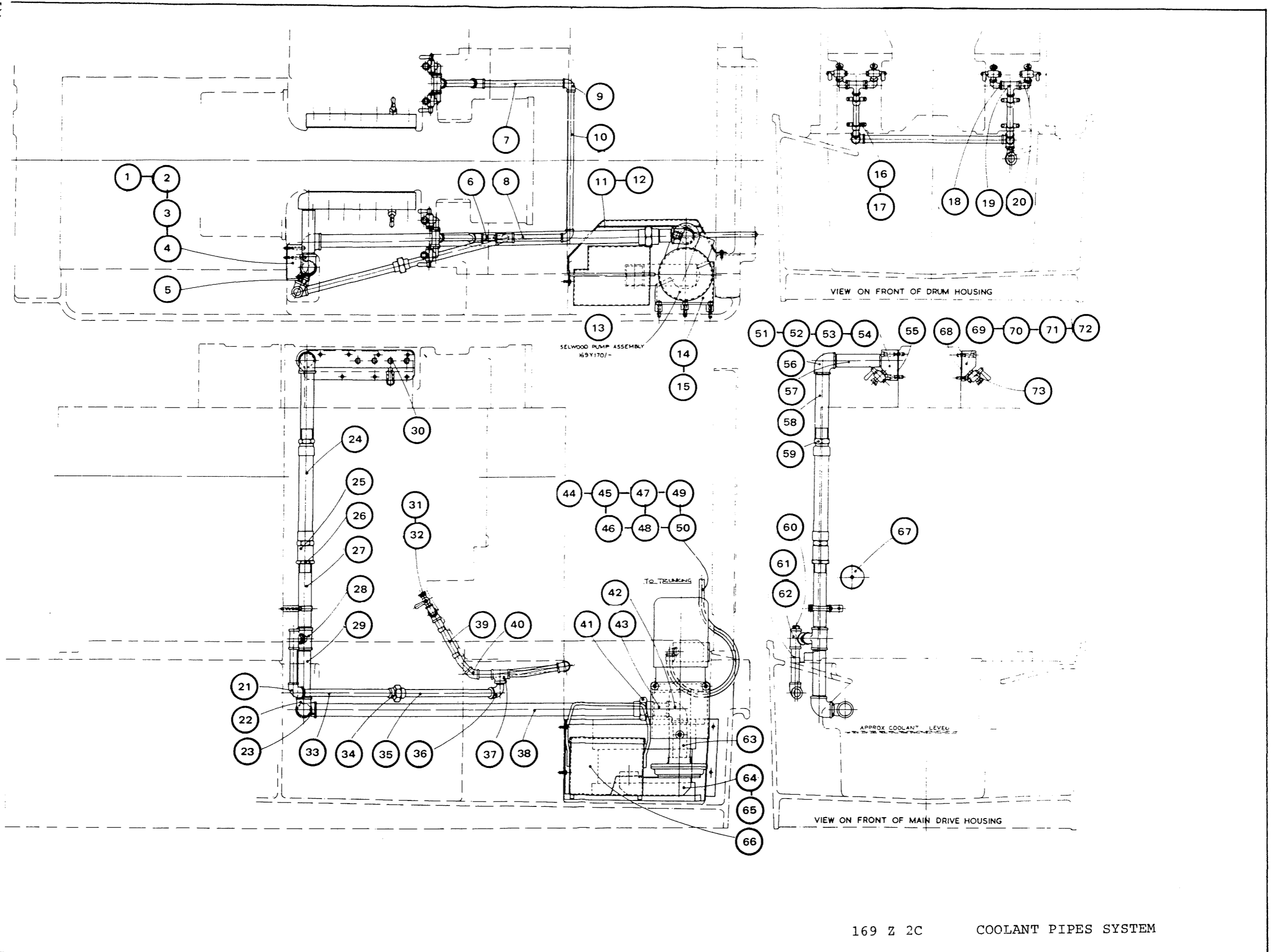

169 Z 2C COOLANT PIPES SYSTEM

Drg No.169Z4B Swarf Tray and Fittings

- | | | |
|----|----------|---|
| 1. | 169Y126C | Rear Cover Strip |
| 2. | 164/0508 | 5/16" B.S.F. Round Head Screw 1/2" long |
| 3. | 169Y127B | Front Cover Strip |
| 4. | 164/0508 | 5/16" B.S.F. Round Head Screw 1/2" long |
| 5. | 169Z120A | Swarf Trough |
| 6. | 169Y121C | Swarf Tray |
| 7. | 169X122A | Swarf Tray Support |
| 8. | 169Z134A | Swarf Basket |

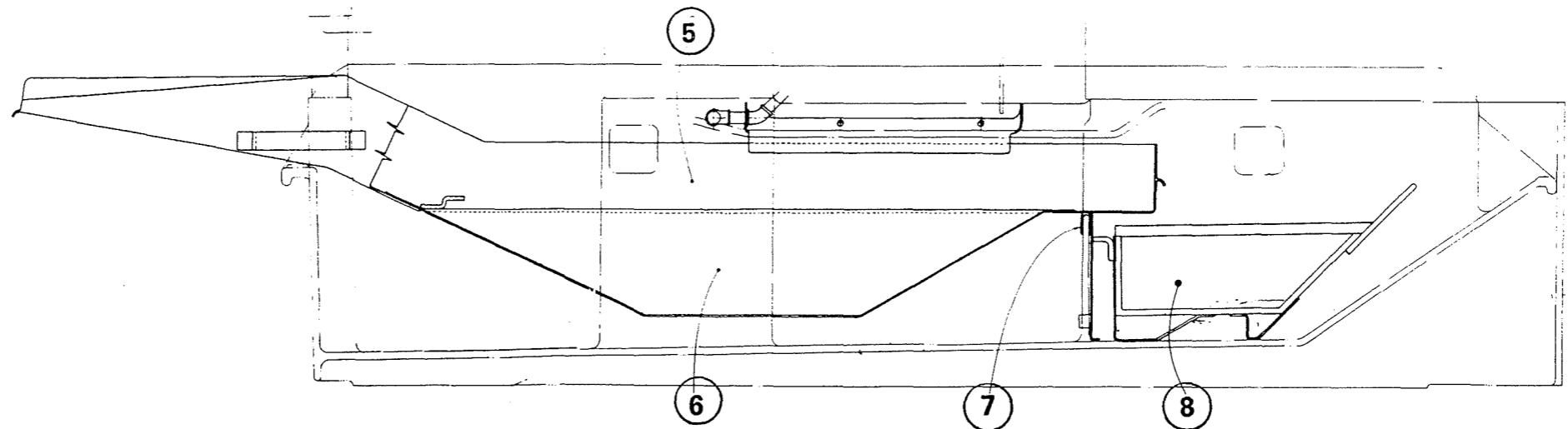
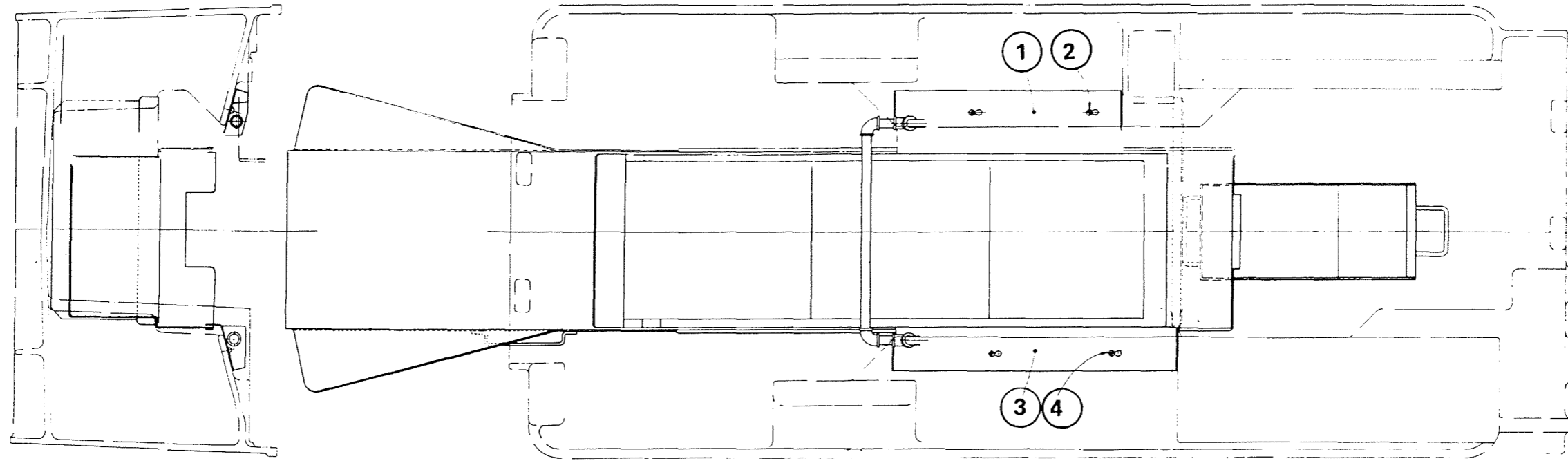

Drg No.171Z1H Arrangement of Conduit Fittings

1.	357/10	5/8" Dowty Washer
2.	347/1280	3/4" Anaconda Type EF x 80" long
3.	15/05	7/8" Cable Clip
4.	165/210	2BA Round Head Screw 5/8" long
5.	15/04.2090	20mm - 3/4" 90 deg. Conduit Connector
6.	11/03/12	20mm Dowty Seal
7.	350/1000	5/8" Conduit Straight Connector
8.	287/242	5/8" Conduit Locknut
9.	237/244	1" Conduit Locknut
10.	357/16	1" Dowty Seal
11.	350/1600	1" Conduit Straight Connector
12.	347/1080	5/8" Anaconda Type EF x 80" long
13.	347/1088	5/8" Anaconda Type EF x 88" long
14.	357/12	3/4" Dowty Seal
15.	237/1210	3/4" to 5/8" Conduit Reducer
16.	357/10	5/8" Dowty Seal
17.	350/1090	5/8" Conduit 90 deg. Connector
18.	237/1210	3/4" to 5/8" Conduit Reducer
19.	357/12	3/4" Dowty Seal
20.	350/1000	5/8" Conduit Straight Connector
21.	357/10	5/8" Dowty Seal
22.	371X132	Gasket
23.	164/0408	1/4" BSF Round Head Screw 1/2" long
24.	371X110	Cover Plate
25.	371Y107B	Bracket
26.	198/16	1/2" BSF Shakeproof Washer
30.	171Z577B	Oil Tight Trunking
31.	165/0410	1/4" BSF Socket Head Cap Screw x 5/8" long
32.	203/04	1/4" BSF Self Locking Nut
33.	171Y578B	Trunking Joint
34.	203/03	2BA Self Locking Nut
35.	156/206	2BA Socket Head Cap Screw x 3/8" long
36.	7362/B/ES	McGeoch Lamp (Red)
37.	110V 15W	Edison Screw Bulb
38.	9214X110	Cover
39.	203/4L	4BA Self Locking Nut
40.	165/408	4BA Round Head Set Screw x 1/2" long
41.	237/353	3/4" Entry Bush
42.	154/07	7/16" Spring Washer
43.	155/0728	7/16" BSF Socket Head Cap Screw x 1.3/4" long
44.	347/1072	5/8" Anaconda Type E.F. x 72" long
45.	194/5	5/8" BSP Plug
46.	347/1046	5/8" Anaconda Type E.F. x 46" long
47.	357/24	1/2" Dowty Seal
48.	237/246	1/2" Conduit Locknut
49.	2372420	1/2" to 1.1/4" Conduit Reducer
50.	350/2000	1/4" Conduit Straight Connector
51.	357/20	1/4" Dowty Seal
52.	247/2040	1/4" Conduit x 40" long
53.	237/1210	3/4" to 5/8" Conduit Reducer
54.	357/12	3/4" Dowty Seal
55.	357/10	5/8" Dowty Seal
56.	350/1000	5/8" Conduit Straight Connector
57.	347/072	5/8" Anaconda Type E.F. x 72" long
58.	237/1210	3/4" to 5/8" Conduit Reducer
59.	357/10	5/8" Dowty Seal
60.	357/12	3/4" Dowty Seal
61.	350/1000	5/8" Conduit Straight Connector
62.	347/1040	5/8" Anaconda Type E.F. x 40" long

63.	DAS 185/12	Dunlop Clip
64.	156/210	2BA Socket Head Cap Screw x 5/8" long
65.	357/10	5/8" Dowty Seal
66.	350/1000	5/8" Conduit Straight Connector
67.	357/12	3/4" Dowty Seal
68.	237/1210	3/4" to 5/8" Conduit Reducer
69.	347/1016	5/8" Anaconda Type E.F. x 16" long
70.	136X120	Support Stud
71.	167/0520	5/16" BSF Hex Head Set Screw x 1.1/4" long
72.	130/05	5/16" Plain Washer
73.	347/1614	1" Anaconda Type E.F. x 14" long
74.	350/2000	1.1/4" Conduit Straight Connector
75.	357/20	1.1/4" Dowty Seal
76.	237/245	1.1/4" Conduit Locknut
77.	237/272	5/8" Conduit Locknut
78.	357/10	5/8" Dowty Seal
79.	237/272	5/8" Conduit Plug
80.	156/210	2BA Socket Head Cap Screw x 5/8" long
81.	328/10	5/8" Clip
82.	171Z23	
83.	171Z24	
84.	11/03/12	20mm Dowty Seal
85.	15/02/1220	20mm Conduit Locknut
86.	1504/2000	20mm to 3/4" Straight Connector
87.	247/1011	5/8" Conduit x 11" long
88.	165/404	4BA Round Head Set Screw x 1/4" long
89.	298A	Warning Flash
90.	350/1090	5/8" Conduit 90 deg. Connector
91.	357/10	5/8" Dowty Seal
92.	237/1210	3/4" to 5/8" Conduit Reducer
93.	357/12	3/4" Dowty Seal
94.	347/2013	1.1/4" Anaconda Type E.F. x 13" long
95.	164X112A	Splash Guard Rail
96.	167/0520	5/16" BSF Hex Head Set Screw x 1.1/4" long
97.	130/05	5/16" Plain Washer
98.	136X121	Support Stud
99.	130/04	1/4" Plain Washer
100.	173/04	1/4" BSF Nut
101.	167/0412	1/4" BSF Hex Head Set Screw x 3/4" long
102.	171X572	Bracket
103.	11/03/09	16mm Dowty Seal
104.	15/04/1690	16mm-5/8" 90 deg. Conduit Connector
105.	357/1025	5/8" Anaconda Type E.F. x 25" long
106.	15/05/12	3/4" Cable Clip
107.	165/210	2BA Round Head Set Screw x 5/8" long
108.	347/1045	5/8" Anaconda Type E.F. x 45" long
109.	15/05/12	3/4" Cable Clip
110.	165/210	2BA Round Head Set Screw x 5/8" long
111.	156/212	2BA Socket Head Cap Screw x 3/4" long
112.	15/04/2001	20mm to 5/8" Straight Conduit Connector
113.	11/03/12	20mm Dowty Seal
114.	11004	Martin & Lunel Interlocked Switch Socket
115.	11/03/09	16mm Dowty Seal
116.	15/04/1600	16mm-5/8" Straight Connector
117.	15/01/1316	13.5 Pg/16mm Adaptor
118.	15/05/12	3/4" Cable Clip
119.	347/1060	5/8" Anaconda Type E.F. x 60" long
120.	165/210	2BA Round Head Set Screw x 5/8" long
121.	167/0520	5/16" BSF Hex Head Set Screw x 1.1/4" long
122.	171Z710	Control Panel Enclosure
123.	171Y573B	Modification to Covers

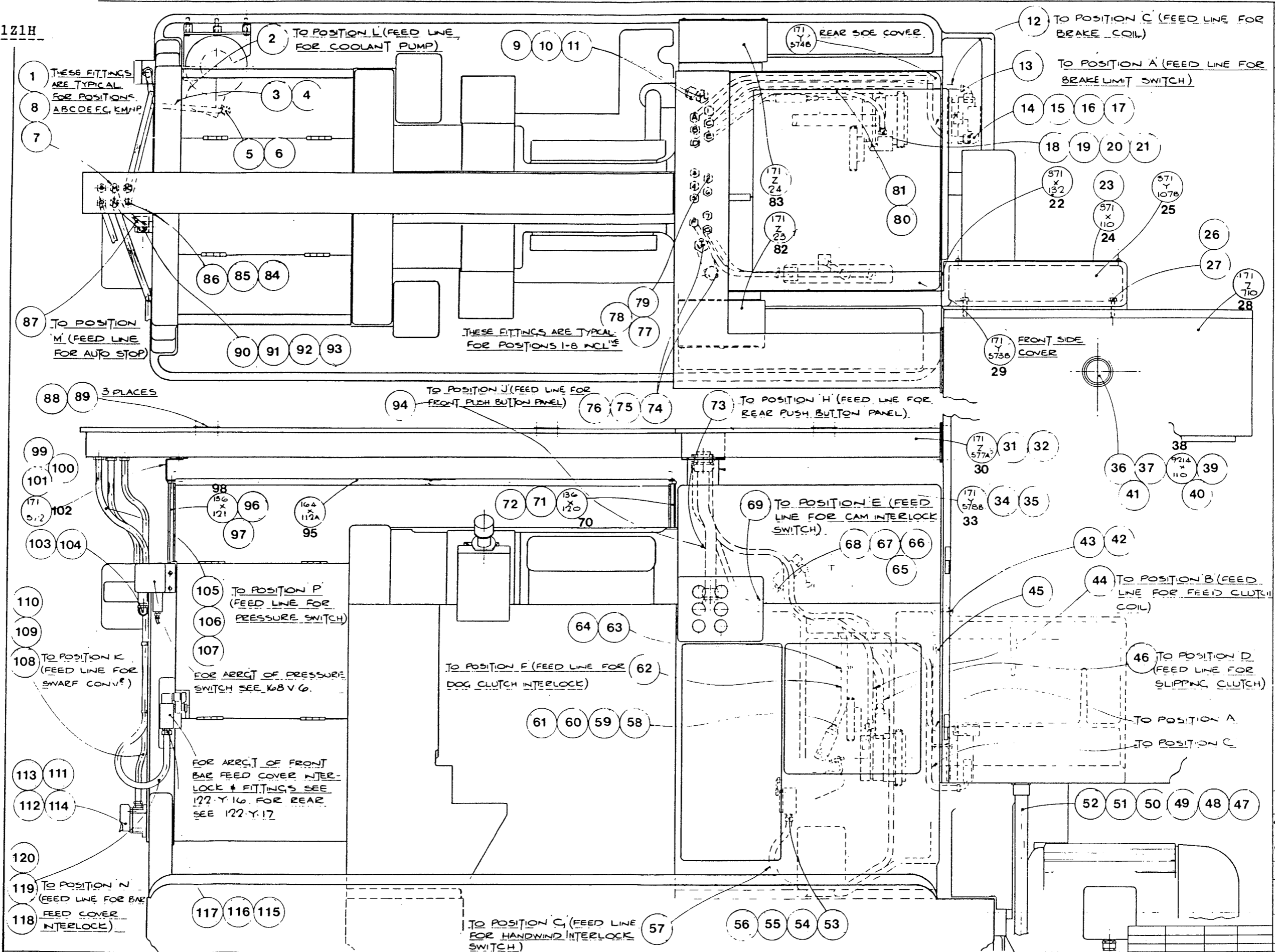

FIRST USED ON	
LAST USED ON	
SUPERSEDED BY	171-Z-1G
SUPERSEDED BY	
ALTERATIONS	REVISED D.P.B. 13 & 20 50/6/65
1" & 8" LIMIT HOLES TO BS 184 1941	
REMOVE ALL SHARP CORNERS UNLESS OTHERWISE STATED	
TOLERANCE ON MACHINING DIMENSIONS & Ø10 UNLESS OTHERWISE STATED	
AMERICAN PROJECTION	
F = ROUGH MACHINE	
FF = FINISH MACHINE	
FFF = GRIND OR EQUIVALENT	
RAW MATERIAL No.	
MARK DRG. No AT (B)	
DRG. No.	171 Z 1H
No. OFF	
ARRANGEMENT DRG. No.	
SECTION	
MACHINE	

WICKMAN MACHINE TOOL MANUFACTURING CO. LTD.
COVENTRY ENGLAND.

COPYRIGHT © THIS DRAWING AND DESIGN IS THE PROPERTY OF WICKMAN MACHINE TOOL MANUFACTURING CO. LTD. COVENTRY, ENGLAND AND IS CONFIDENTIAL. IT MUST NOT BE LOANED, COPIED OR OTHERWISE COMMUNICATED TO A THIRD PARTY WITHOUT PERMISSION AND IS SUBJECT TO RECALL AT ANY TIME.

DESCRIPTION
ARRANGEMENT OF CONDUIT & FITTINGS

SCALE	1:4
DRAWN	DPB
CHECKED	
TRACED	
TRACING	
CHECKED	
MATERIAL	

<u>Drg No.</u>	<u>175Z1C</u>	<u>Stock Carriage</u>
1.	155/0624	3/8" B.S.F. Socket Head Cap Screw 1.1/2" long
2.	155/0420	1/4" B.S.F. Socket Head Cap Screw 1.1/4" long
3.	154/04	1/4" Spring Washer
4.	175X104	Spring Retaining Cap
5.	175X101A	Stock Tube
6.	175Z108B	Stock Carriage Stand
7.	175Y118A)	
8.	175X102A)	Stock Tube Assembly 175Z122B
9.	175Y118A)	
10.	175X127C	Pin
11.	175V125B	Adaptor
12.	101/4	External Circlip
13.	175X109	Bush
14.	158Y150A	Driving Disc
15.	178/0506	5/16" B.S.F. Socket Set Screw Half Dog Point 3/8" long
16.	175X126	Spring Cap
17.	175X119B	Stock Carriage Spring for 1" Capacity
	175X135	Stock Carriage Spring for 3/8" Capacity (optional extra)
18.	156/206	2BA Socket Head Cap Screw 5/8" long
19.	101X172	Key
20.	101Y165A	Driving Coupling
21.	155/0636	3/8" B.S.F. Socket Head Cap Screw 2.1/4" long
22.	154/06	3/8" Spring Washer
23.	158X164B	Eccentric Roller Pin
24.	RHP6305-2RS	Double Seal Bearing
25.	130/14	7/8" dia. Flat Washer
26.	175X130	Stop Screw
27.	203/08L	1/2" B.S.F. Self Locking Hexagon Locknut
28.	175V103E	Nush for Stock Tube
29.	130/12	3/4" dia. Flat Washer
30.	173/12L	3/4" B.S.F. Hexagon Locknut
31.	130/14	7/8" dia. Flat Washer
32.	RHP6305-2RS	Double Seal Bearing
33.	175X116A	Roller Pin
34.	188/1240	3/4" B.S.F. Square Head Set Screw 2.1/2" long
35.		Supplied by Customer
36.	175X109	Nylon Pad
37.	101/4	5/8" External Circlip
38.	173/12L	3/4" B.S.F. Hexagon Locknut
39.	130/12	3/4" dia. Flat Washer
40.	130/12	3/4" dia. Flat Washer
41.	122Z102C	End Bracket
42.	118X141	Spring Retaining Plug
43.	175X132	Spring
44.	175X131	Plunger

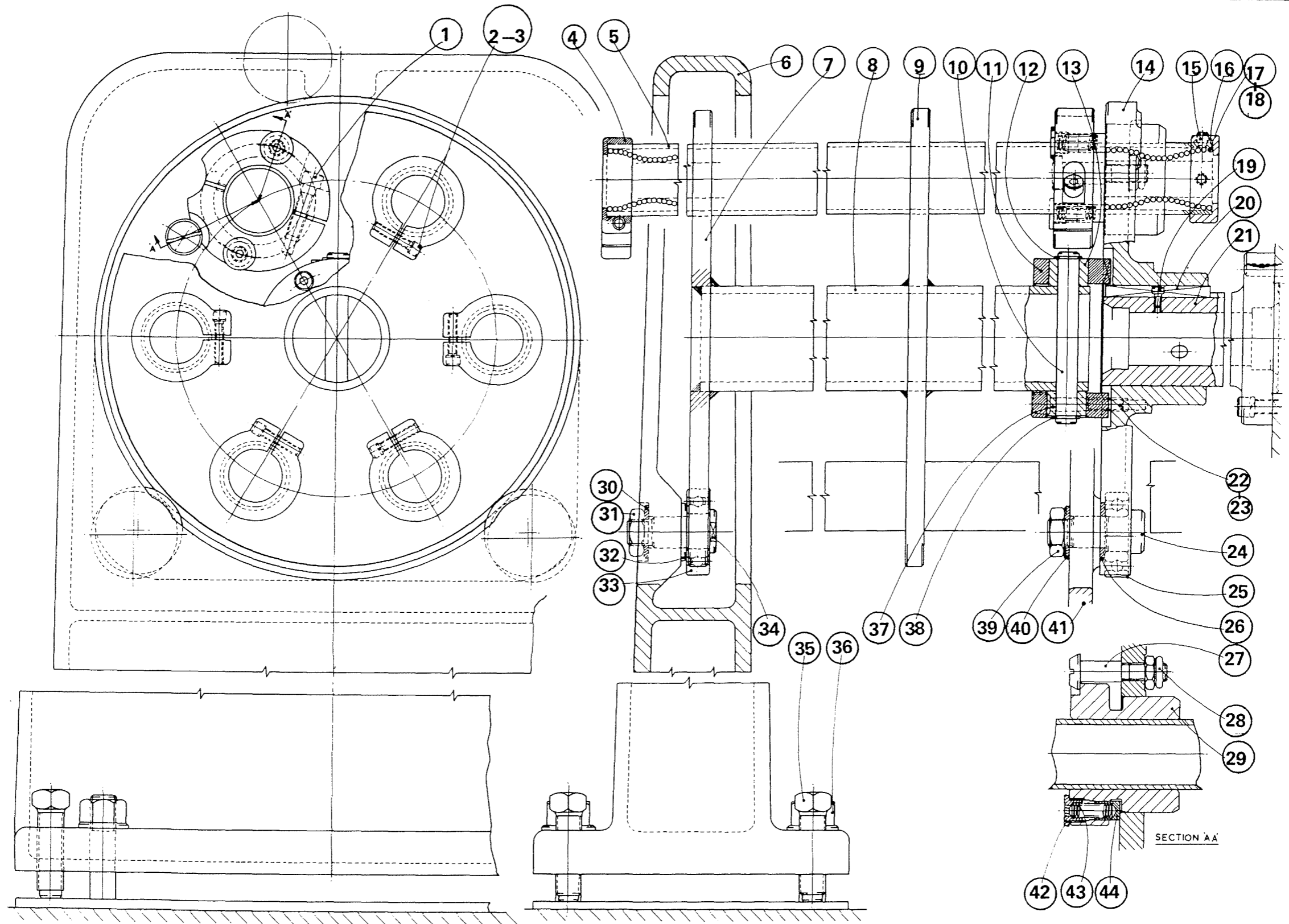

Drg No.181AY3 ----- Herbert Clutch Drive - Section 181A

1.	173/10L	5/8" Hexagon Locknut
2.	181AX118A	Operating Spring
3.	181AX108	Latch Link Fork
4.	181AX104A	Latch
5.	181AX105	Latch Bush
6.	236/141612	Oil Retaining Bush
7.	181AX101A	Trip Sleeve
8.	181AX113A	Buffer Bush
9.	181AX121	Hexagon Nut
10.	181AV101B	Shaft
11.	181AX121	Hexagon Nut
12.	181AX115	Spring Anchor Sleeve
13.	181AX128	Spring Anchor
14.	181AX128	Spring Anchor
15.	155/0528	5/16" B.S.F. Socket Head Cap Screw 1.3/4" long
16.	154/05	5/16" Spring Washer
17.	181AX107	Latch Link Pin
18.	127/0405	1/16" Split Pin 5/8" long
19.	181AX106	Latch Pivot Pin
20.	127/0405	1/16" Split Pin 5/8" long
21.	154/04	1/4" Spring Washer
22.	155/0428	1/4" B.S.F. Socket Head Cap Screw 1.3/4" long
23.	181AX131	Gear Spacer
24.	181AX130	Staggered Gears Centre
25.	181DX110	Pin
26.	181AX125A	End Bearing Housing
27.	181AX126	Oil Nipple
28.	181AX133	Clamp Plate
29.	218/2	1/8" B.S.P. Tube Adaptor 3/16" Tube
30.	221/3	Tubing Sleeve 3/16" dia.
31.	215/3	Ends Tubing Nut 3/16"
32.	225/3035	16" Dia. Copper Tube 3' long.
33.	155/0412	1/4" B.S.F. Socket Head Cap Screw 3/4" long
34.	154/04	1/4" Spring Washer
35.	MSF.318	Extension Spring

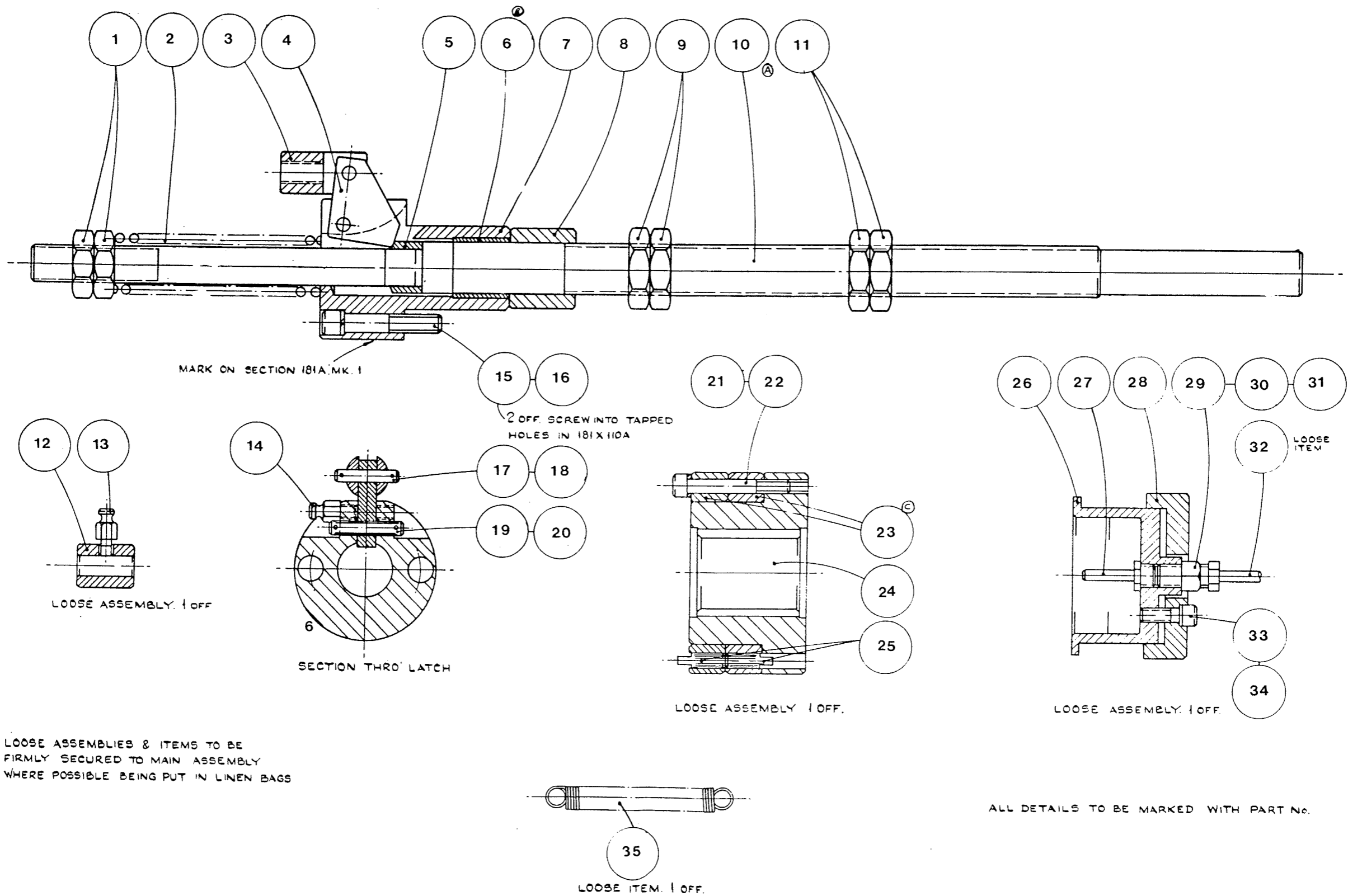

Drg No. 182V1C Threading Attachment Drive Sleeve, MK II.Sec.182

1.	NT/F084	1/4" B.S.F. Pinnacle Nut
2.	155/0412	1/4" B.S.F. Socket Head Cap Screw 3/4" long
3.	154/04	1/4" Spring Washer
4.	182X108	Coupling Stud
5.	182X106	Bearing Spacer
6.	155/0514	5/16" B.S.F. Socket Head Cap Screw 7/8" long
7.	154/05	5/16" Spring Washer
8.	150/22	1.3/8" Slotted Locknut
9.	176/0805	1/4" B.S.F. Socket Set Screw 5/16" long
10.	153/04	Soft Pad 3/32" long
11.	182Y101B	Threading Drive Sleeve
12.	258/35S	Ball Journal Bearing 35 x 72 x 17mm (with one dust shield)
13.	182X104B	Threading Drive Housing
15.	258/35	Ball Journal Bearing 35 x 72 x 17mm
16.	182X109	Coupling Pin
17.	182X115	Die Head Drive Adaptor Plate

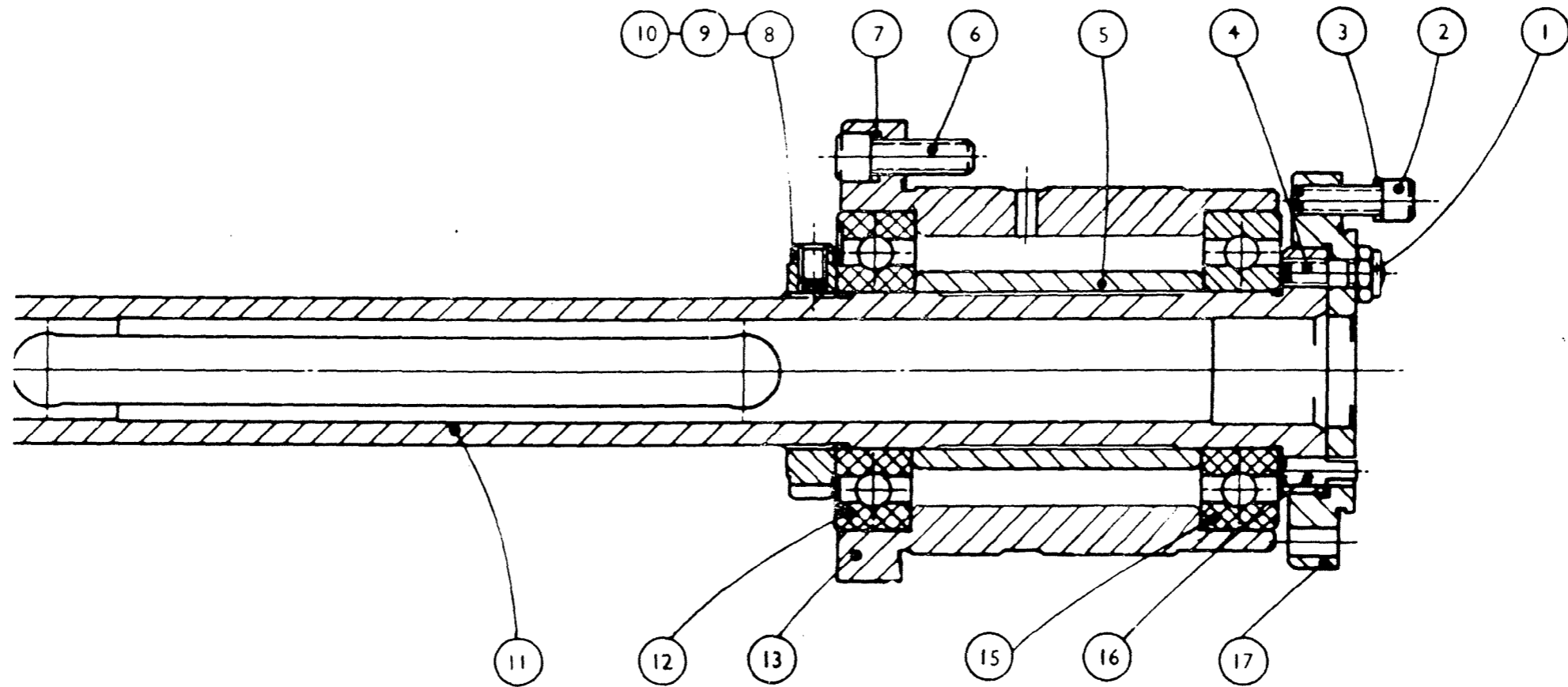

Threading Attachment Drive Sleeve, MK II -
Section 182:

Drg No. 182V1C

- 1. - Driven Gear (see table below)
- 2. 104/29 Internal Circlip 52mm
- 3. 258/25Z Light Ball Journal - 3 Dot Fit 25 x 52 x 15mm
- 4. 183X109 Clutch Thrust Plate
- 5. 183X111 Clutch Key
- 6. 126/0812 1/4" dia. Dowel 3/4" long
- 7. 183Y101E Herbert Clutch Glut
- 8. 183X102 Strip Nut
- 9. 155/0526 5/16" B.S.F. Socket Head Cap Screw 1.5/8" long
- 10. 154/05 5/16" Spring Washer
- 11. 183X111 Clutch Key
- 12. 183X109 Clutch Thrust Plate
- 13. 258/25Z Light Ball Journal - 3 Dot Fit 25 x 52 x 15mm
- 14. 104/29 Internal Circlip 52mm
- 15. 258/25Z Light Ball Journal - 3 Dot Fit 25 x 52 x 15mm
- 16. 168X160 Oil Bush
- 17. 155/0420 1/4" B.S.F. Socket Head Cap Screw 1.1/4" long
- 18. 153/42 Soft Pad 1/4" dia.
- 19. 179/204 2BA Cup Point Grub Screw
- 20. 151/20 20mm Locknut
- 21. 257/20 Medium Ball Journal Bearing 20 x 52 x 15mm
- 22. 183X113 Bearing End Spacer
- 23. 183X112 Bearing Spacer
- 24. 154/04 1/4" Spring Washer
- 25. 155/0410 1/4" B.S.F. Socket Head Cap Screw 5/8" long
- 26. 183X114 Forward Clutch Cup
- 27. 183Y106 Herbert Clutch Sleeve
- 28. 121/0832T Clutch Sleeve Key, 1/4" x 1/4" x 2"
- 29. 183X112 Bearing Spacer
- 30. 258/25Z Light Ball Journal - 3 Dot Fit 25 x 52 x 15mm
- 31. 183Y105B Herbert Clutch Shaft
- 32. - No. 4 Herbert Clutch modified

DRIVEN GEAR	
NO. OF TEETH	REF. NO.
28	183X125/28
29	183X125/29
30	183X125/30
31	183X125/31
32	183X125/32
33	183X125/33
34	183X125/34
35	183X125/35
36	183X125/36

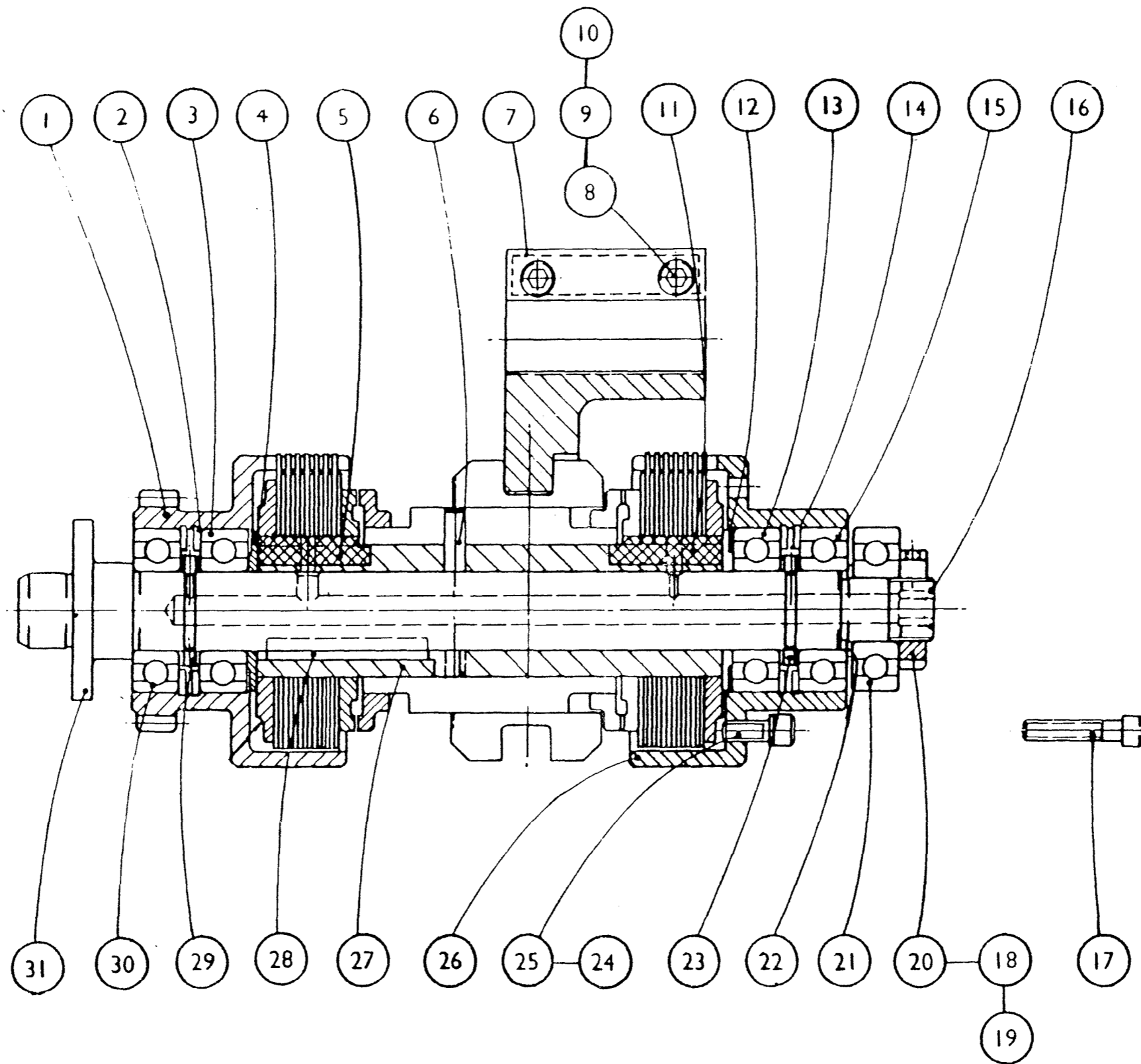

Herbert Clutch Drive - Section 183:

Drg No. 183Y3

Drg No. 186Y1B

Parts Common to Threading Attachment MK II
Stations 3, 4, 5 & 6 - Section 186

1.	186X112	Thrower Ring
2.	186X111	Locking Ring
3.	258/35	Light Metric Ball Journal 35 x 72 x 17mm
4.	153/04	Soft Pad
5.	176/0405	1/4" B.S.F. Socket Set Screw 5/16" long
6.	150/22	1.3/8" x 22 T.P.I. Slotted Locknut
7.	181DX110	Threading Gear Pin
8.	186X109A	Threading Spindle Housing
9.	186X136	Locknut
10.	186Y106A	Threading Spindle
11.	186X114A	Roller Pin
12.	355/206	2.1/16" Dia. Retaining Ring
13.	186X113A	Roller
14.	186X137A	Spring Anchor Clamp
15.	195/0516H	5/16" B.S.F. Sq. Head Screw (Naylor) 1" long
16.	386X148	Spring Anchor
17.	186X121	Return Spring
18.	186X135	Pusher Spring Sleeve
19.	FX6460	Feed Spring
20.	186X124	Pusher Sleeve Locknut
21.	212/04	1/4" B.S.F. Autolub Nipple
22.	210/1725	Yellow Indicator Washer
23.	186X115A	Drive Pin
24.	186X129	Retaining Collar

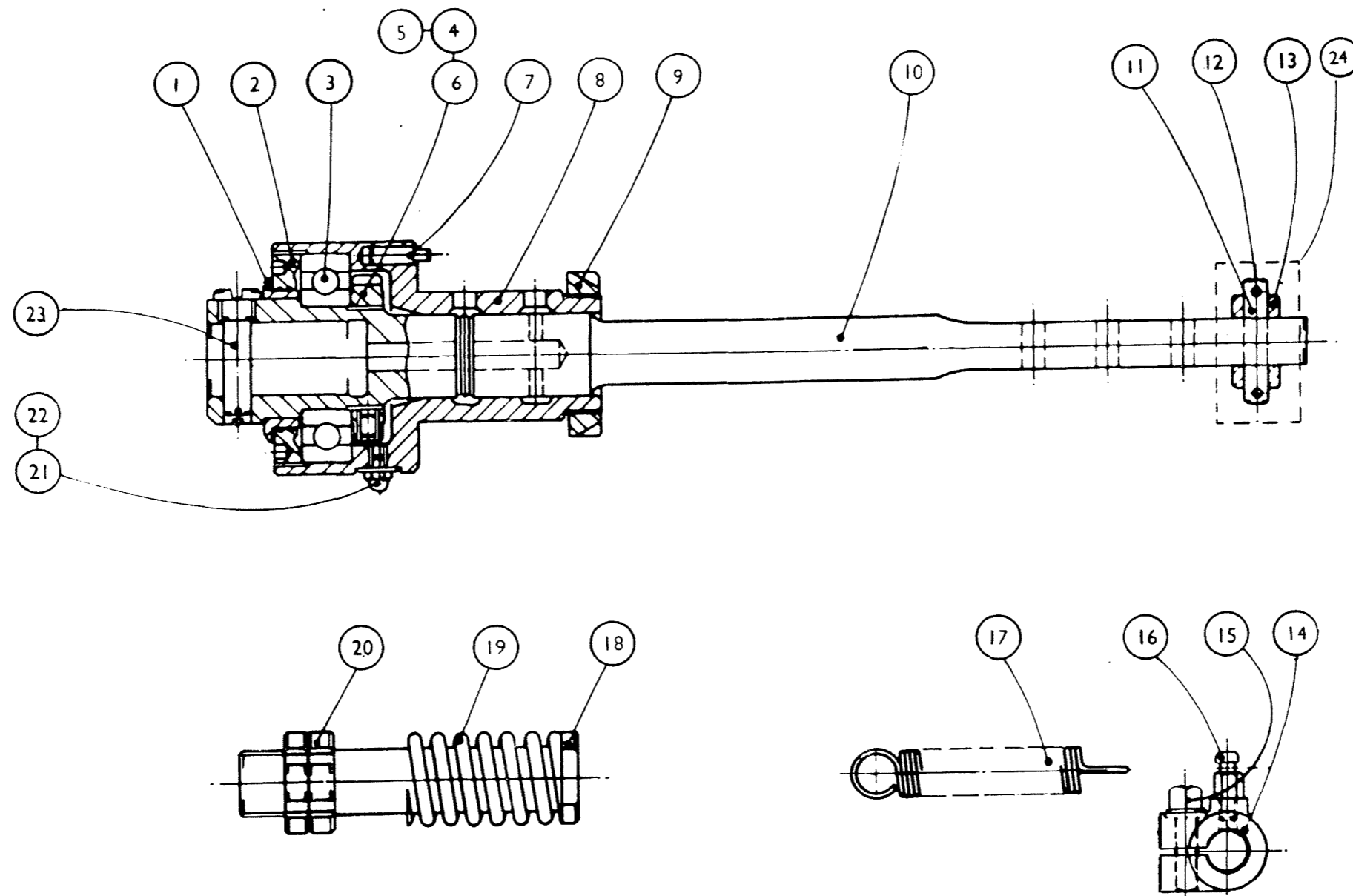

Parts Common to Threading Attachment MK II
Stations 3, 4, 5 & 6 - Section 186:

Drg No. 186Y1B

Drg No. 186AY1A Threading Attachment, Extra Parts, Sec.186A

1. 195/0516H 5/16" B.S.F. Sq. Head Screw (Naylor) 1" long
2. 189 AX115 Trip Clamp
3. 186AV101D Threading Bracket
4. 186AX122A Push Rod
5. 186AX106 Setscrew
6. 186AX105 Pusher Connection Plate
7. 173/10L 5/8" B.S.F. Hexagon Locknut
8. 186X148 Spring Anchor
9. 176/0406 1/4" B.S.F. Socket Set Screw 3/8" long
10. 186AX104 Anchor Block
11. 167/0640 3/8" B.S.F. Hex. Head Set Screw 2.1/2" long
12. 167/0624 3/8" B.S.F. Hex. Head Set Screw 1.1/2" long
13. 154/04 4" Spring Washer
14. 155/0420 1/4" B.S.F. Socket Head Cap Screw 1.1/4" long
15. 186AY110 Glut Shifting Fork.

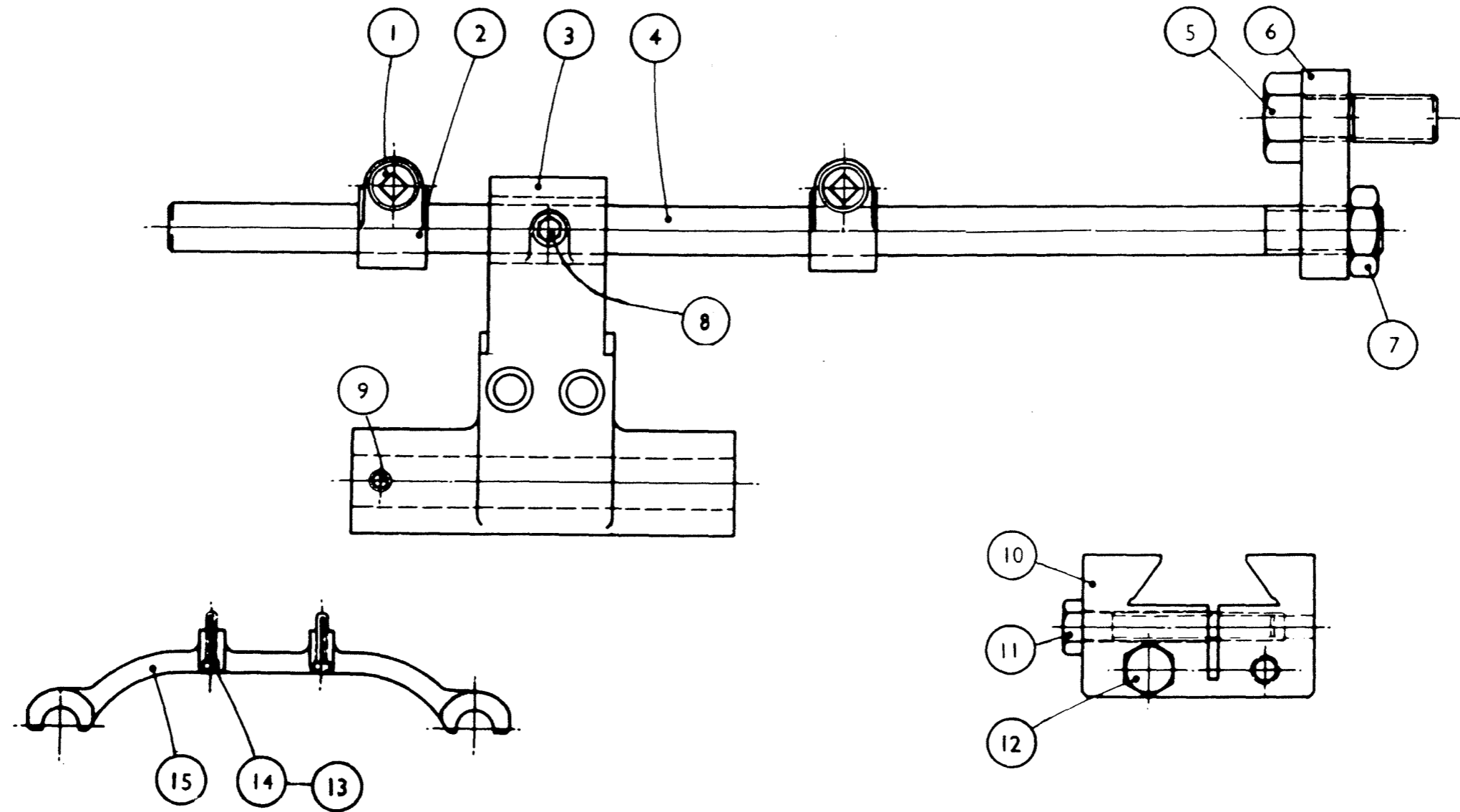

THREADING ATTACHMENT EXTRA PART

186 AY1A

Drg No. 186BY2B 4th & 5th Stns. Threading Cams Mk.IV Secs.186B & 186C

1. 154/06 3/8" Spring Washer
2. 155/0636 3/8" B.S.F. Cap Screw x 2.1/4" long
3. 186BX106 Stop
4. 124Y123/2) Longitudinal Slide Outer Cam
5. 124Y123/1)
6. 186V145 Threading Return Cam 5th Station
7. 186V141 Threading Cam - 5th Station
8. 125Y105/1) Longitudinal Slide Outer Cam
9. 125Y105/2)
10. 186V146 Threading Return Cam 4th Station
11. 186V143 Threading Cam - 4th Station

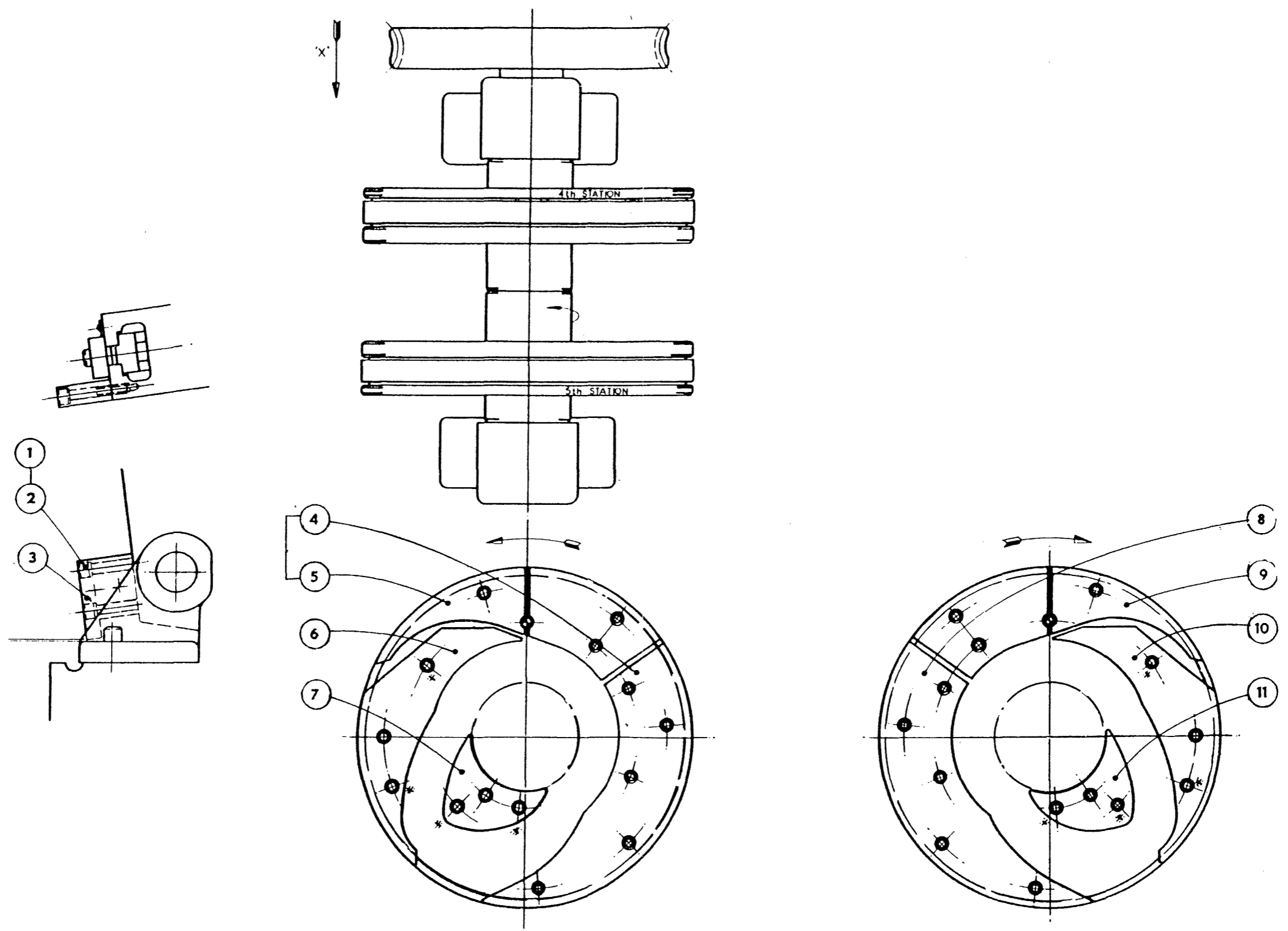

4TH & 5TH STATION THREADING CAMS MARK IV SECTION 186B & SECTION 186C

186 BY2B

Drg No. 186DX1A Pusher Bracket/Threading & Reaming Attch. Stns 3 & 6

1. 386X148 Spring Anchor
2. 186DV101B Threading Bracket
3. 176/0406 1/4 BSF Set Screw x 3/8" long

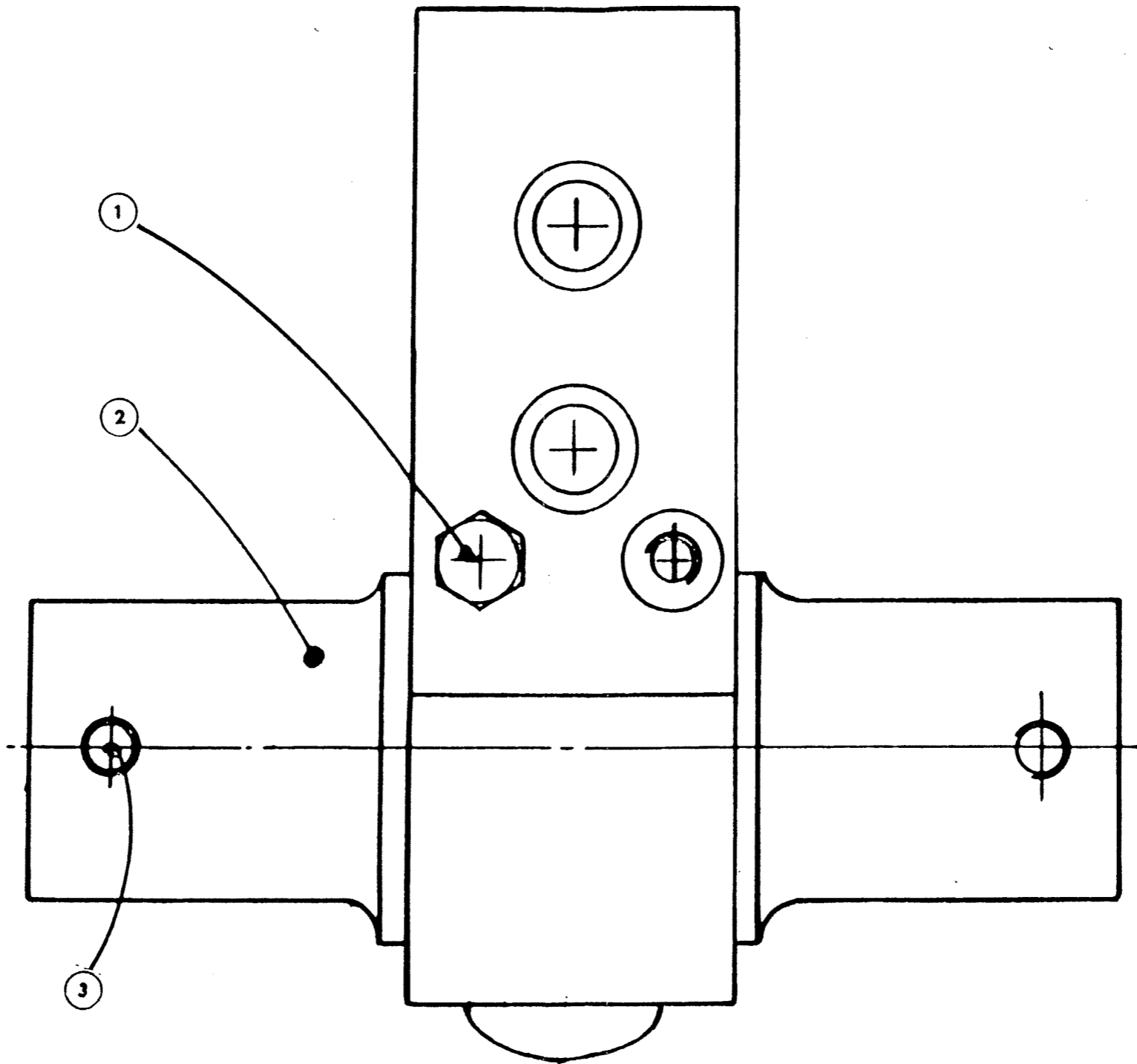

PUSHER BRACKET THREADING AND REAMING ATTACHMENT STATIONS 3 & 6

186 DX1A

Drg No. 186V20A Threading Attachment - Return Check Switch Sec.186F

- | | | | |
|-----|--------------|---|---------|
| 1. | 186X150A | Switch Base | |
| 2. | MSC140 | Morris Spring | |
| 3. | 158X124A | Plunger | |
| 4. | WSP143/0812B | Mills Grooved Pin 1/4" Dia. x 3/4" long | |
| 5. | 181AX108 | Link Fork | |
| 6. | WSP173/06L | Hex. Locknut 3/8" B.S.F. | |
| 7. | WSP195/0512 | Collar Head Screw 5/16" BSF 3/4" long | |
| 8. | 188X108 | Trip Clamp | |
| 9. | WSP145/176 | Compression Spring 5/8" O.D., 3.1/2" long | |
| 10. | 186X152 | Operating Rod | |
| 11. | WSP178/0412 | Socket Set Screw 1/4" BSF, 3/4" long | |
| 12. | WSP203/04 | Self Locking Nut 1/4" BSF | |
| 13. | WSP155/0414 | Hex. Cap Screw 1/4" BSF, 7/8" long | |
| 14. | 291/11 | Legend Plate | |
| 15. | 165/404 | Round Head Set Screw 4BA, 1/4" long | |
| 16. | 186/151 | Lever | |
| 17. | WSP143X0816B | Mills Grooved Pin, 1/4" dia. 1" long | |
| 18. | Type B53E | Square 'D' Limit Switch | |
| 19. | WSP156/232 | Hex. Cap Screw 2BA, 2" long | |
| 20. | WSP154/03 | Spring Washer for 3/16" dia. | |
| 21. | 180X153 | Top Plate | |
| 22. | WSP167/0636 | Hex. Head Set Screw, 3/8" BSF 2.1/4" long) | Station |
| 23. | WSP203/06 | Self Locking Nut, 3.8" B.S.F. |) 4 & 5 |
| 24. | WSP155/0616 | Socket Head Cap Screw, 3/8" B.S.F. 1" long) | Station |
| 25. | WSP154/06 | Spring Washer for 3.8" dia. |) 3 & 6 |

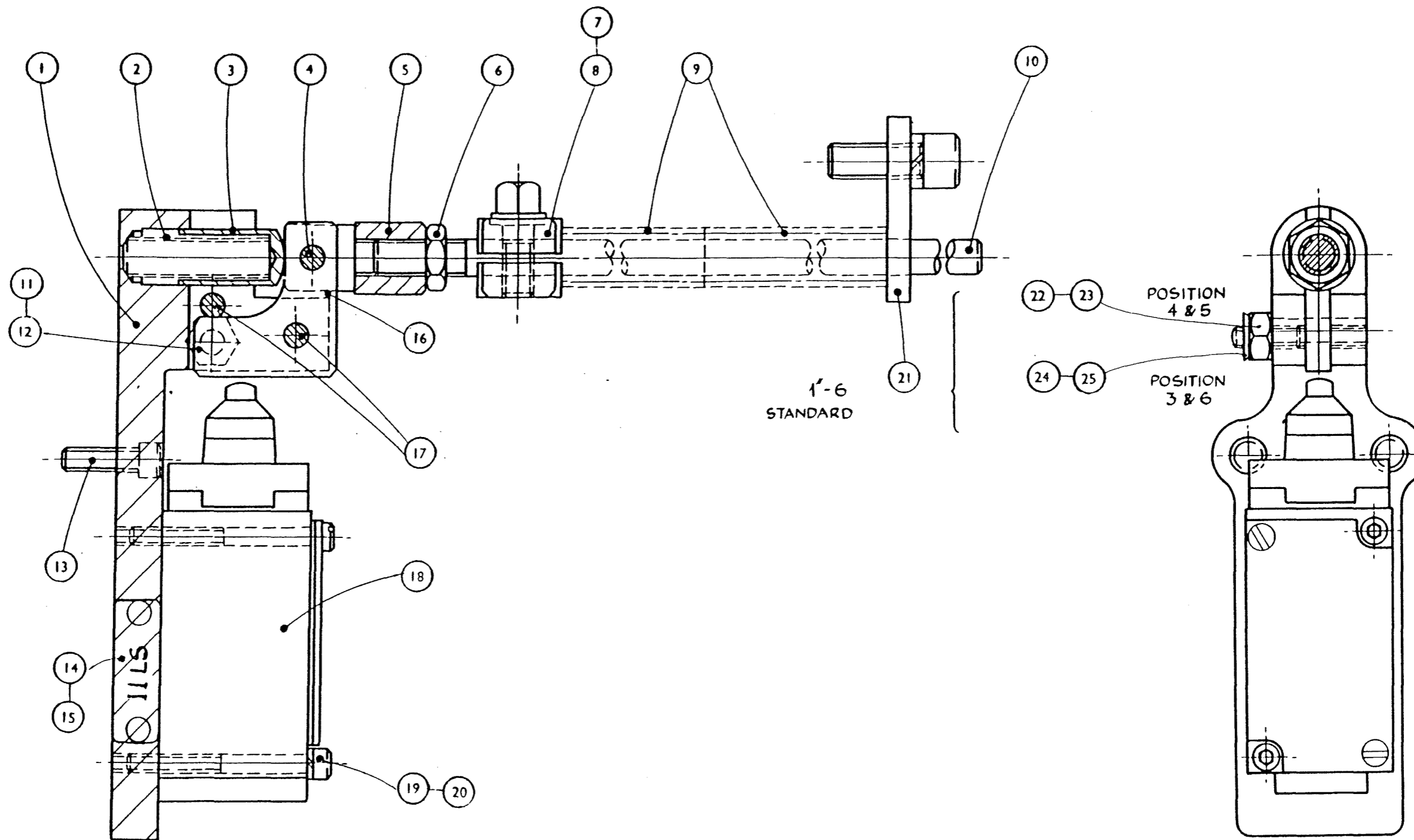

THREADING ATTACHMENT RETURN CHECK SWITCH SECTION 186F

186V20A

Drg No. 187Y1A,2A & 3A Auxiliary Longitudinal Motion Cams. Sec.187

1. 187V102/4A Reaming Cam 3rd Station
2. 187V102/3A Reaming Cam 3rd Station
3. 187V102/2A Reaming Cam 3rd Station
4. 187V102/1A Reaming Cam 3rd Station
5. WSP155/0612 3/8" BSF Hex. Socket Head Cap Screw 3/4" L.
6. 187V105A Return Cam 3rd Station
7. 187V107 Return Cam 6th Station
8. 187V101/1A Reaming Cam 6th Station
9. 187V101/2A Reaming Cam 6th Station
10. 187V101/3A Reaming Cam 6th Station
11. 187V101/4A Reaming Cam 6th Station
12. WSP155/0612 3/8" BSF Hex. Socket Head Cap Screw 3/4" L.
13. 187V107 Return Cam 6th Station
14. WSP155/0612 3/8" BSF Hex. Socket Head Cap Screw 3/4" L.
15. 187V103/4A Threading Cam 3rd Station
16. 187V103/3A Threading Cam 3rd Station
17. 187V103/2A Threading Cam 3rd Station
18. 187V103/1A Threading Cam 3rd Station
19. WSP.155/0612 3/8" BSF Hex. Socket Head Cap Screw 3/4" L.
20. 187V105A Return Cam 3rd Station
21. 187V105A Return Cam 3rd Station
22. 187V107 Return Cam 6th Station
23. 187V104/1A Threading Cam 6th Station
24. 187V104/2A Threading Cam 6th Station
25. 187V104/3A Threading Cam 6th Station
26. 187V104/4A Threading Cam 6th Station
27. WSP155/0612 3/8 BSF Hex. Socket Head Cap Screw 3/4" L.
28. 187V107 Return Cam 6th Station
29. 187Y106/2A Reaming Cam 6th Station Standard Timing
30. 187Y106/1A Reaming Cam 3rd Station Standard Timing
31. 187V105A Return Cam 3rd Station
32. WSP155/0612 3/8" BSF Hex. Socket Head Cap Screw 3/4" L.
33. 187V105A Return Cam 3rd Station
34. WSP155/0612 3/8" BSF Hex. Socket Head Cap Screw 3/4" L.

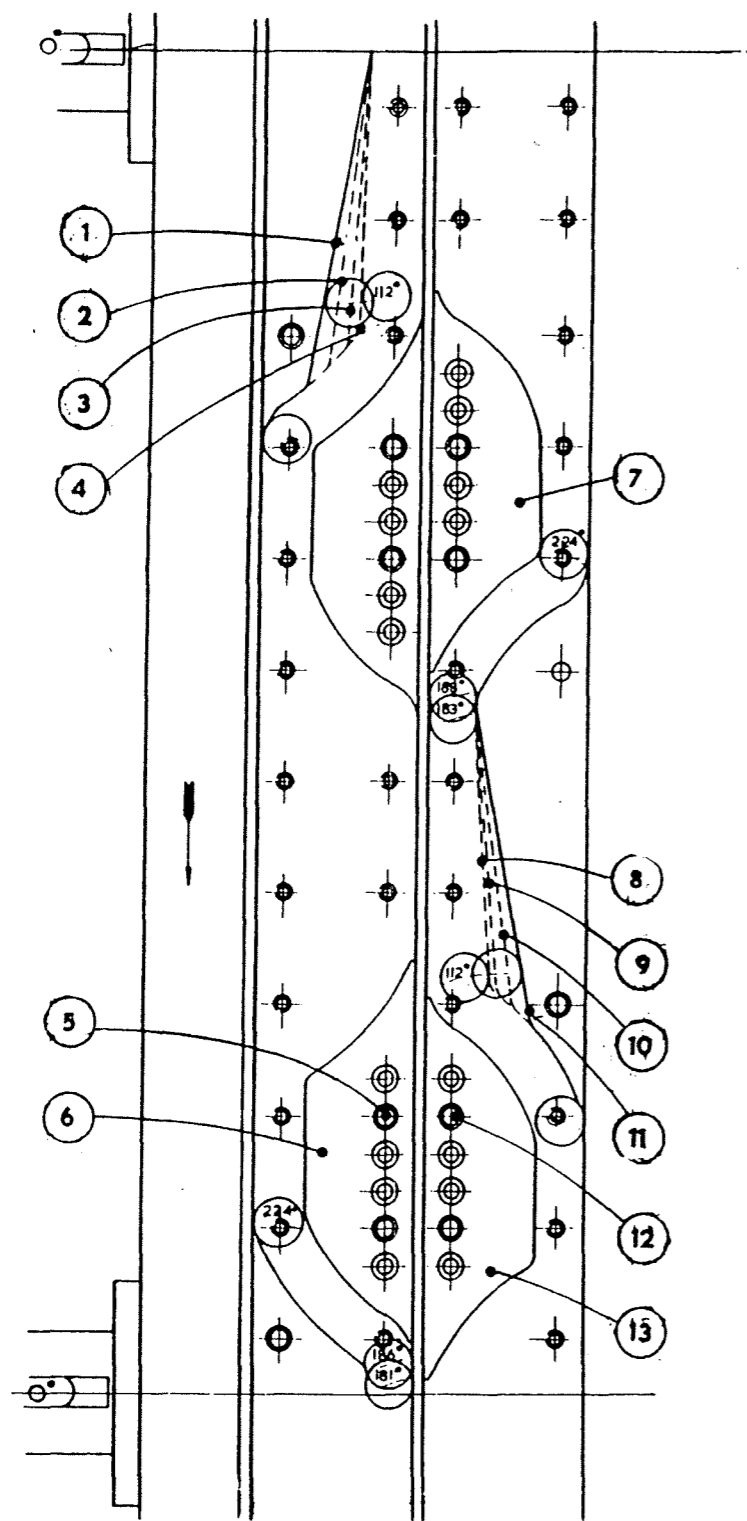

187 Y1A

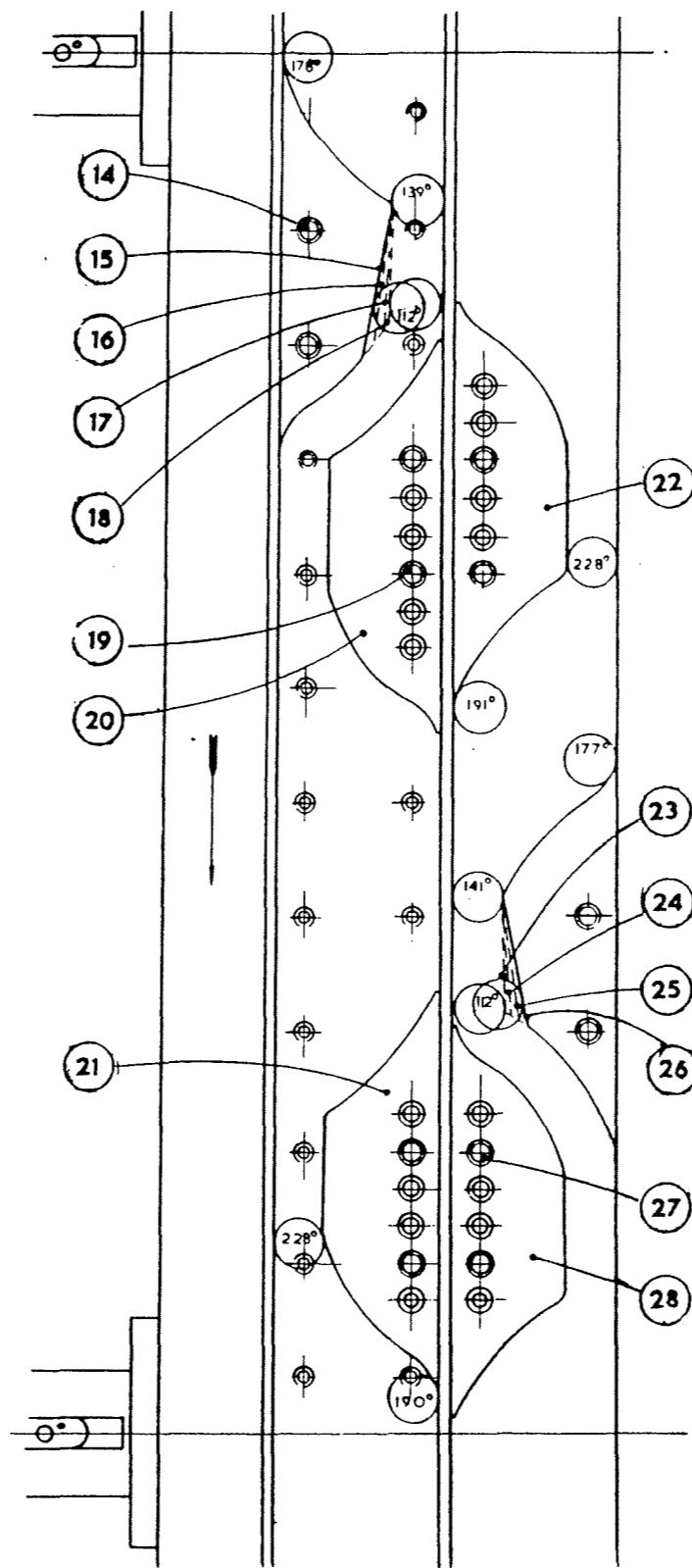

187 Y2A

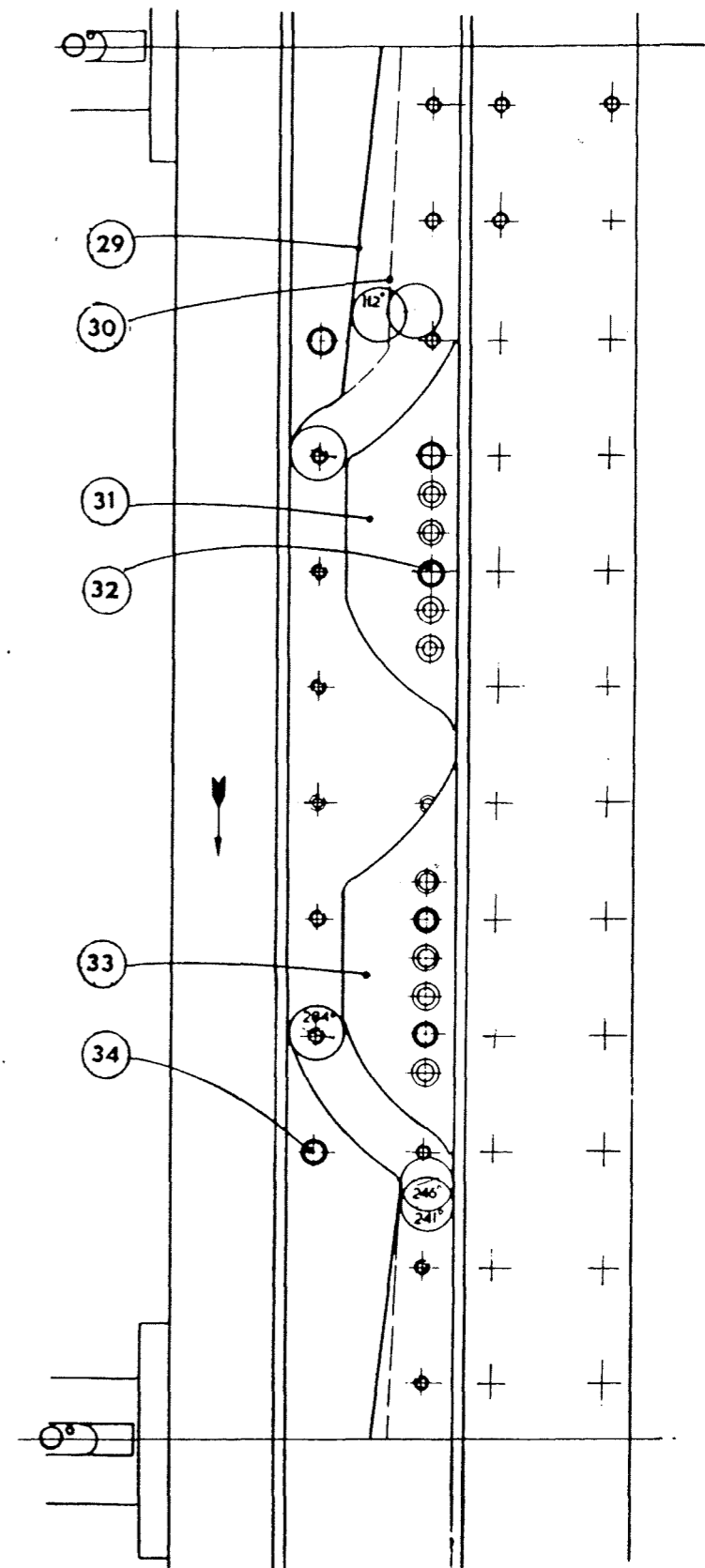

187 Y3A

AUXILIARY LONGITUDINAL MOTION CAMS SECTION 187

187Y1A, 2A, 3A

Drg No. 188Y1C Attachment Body & Slide - Stns.3,4,5 & 6. Sec.188

1.	194/2	1/4" B.S.P. Plug
2.	188X107	Guide Strip
3.	156/208	2BA Socket Head Cap Screw 1/2" long
4.	155/0620	3/8" B.S.F. Socket Head Cap Screw 1.1/4" long
5.	188/0616	3/8" B.S.F. Square Head Set Screw 1" long
6.	-	90 deg. Male & Female Elbow 1/4" B.S.P.
7.	AD18	1/4" to 1/2" Reducing Nipple
8.	188X111	T Nut
9.	155/0508	5/16" B.S.F. Socket Head Cap Screw 1/2" long
10.	188Y101C	Attachment Body
11.	188Y103C	Slide
12.	188X110	Trip Rod (Short)
13.	188X109	Nut
14.	188X108	Trip Clamp
15.	195/0512H	5/16" B.S.F. Square Head Screw (Naylot) 3/4" long
16.	188X106	Trip Rod Bush
17.	288X110	Trip Rod (Long)

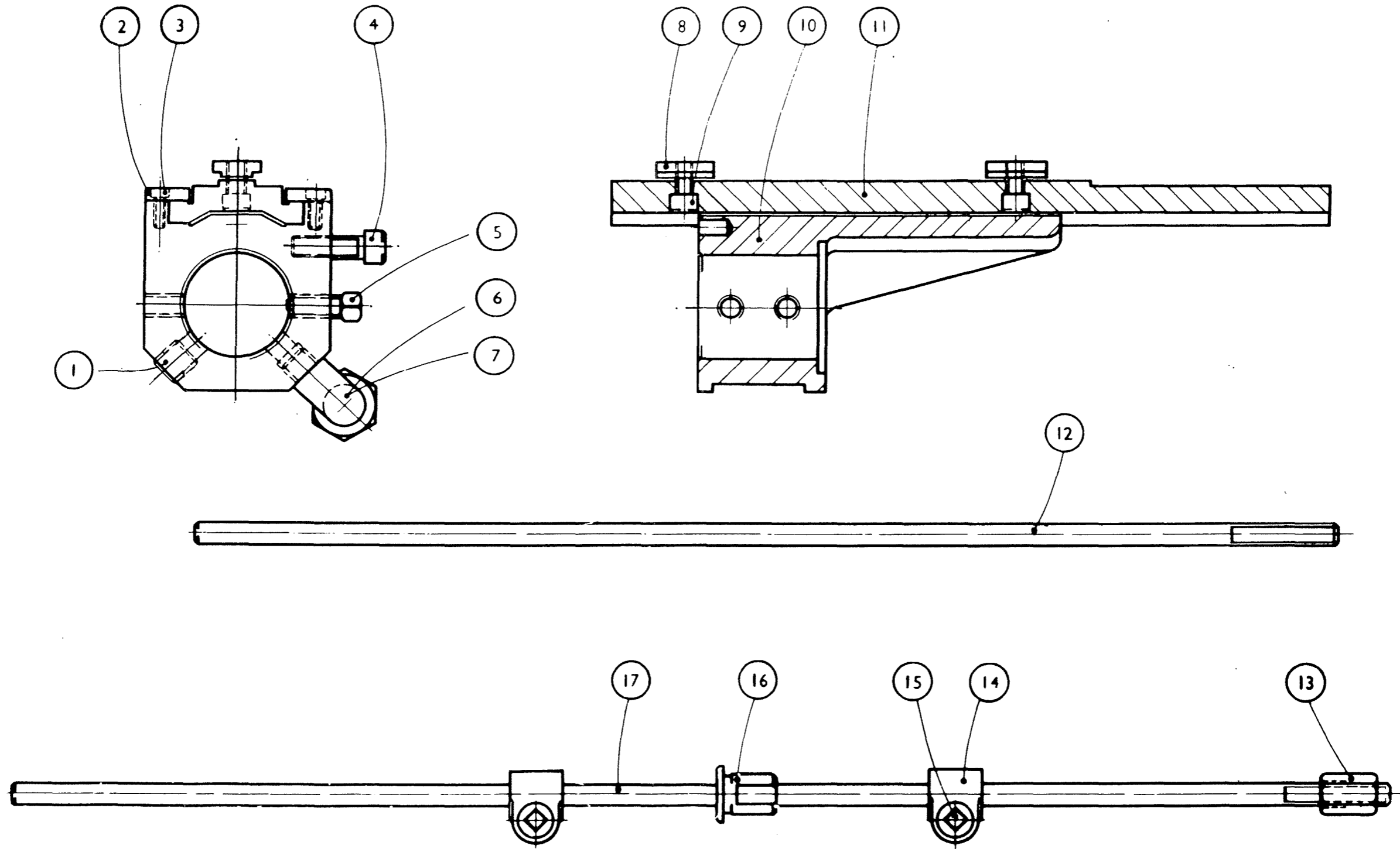

ATTACHMENT BODY AND SLIDE - STATIONS 3,4,5 and 6

188 Y IC

Drq No. 189AZ1A Attachment Longitudinal Motion - Stn.6. Sec.189A

1.	150X130	Cam Roller
2.	150X129	Cam Roller Pin
3.	189AX119A	Shear Pin Centre Bush
4.	189AX120	Cam Roller
5.	189AX121	Cam Roller Pin
6.	189AX123	Quadrant Pivot Pin
7.	189AX129	Spring Anchor
8.	195/0516H	5/16" B.S.F. Collar Headed Screw (Naylor) 1" long
9.	189AX115	Push Rod Clamp
10.	189AX114	Push Rod Extension
11.	189AX131	Push Rod Bush
12.	189AY110A	Push Rod
13.	189AX111	Push Rod Guide
14.	189AX113	Push Rod Adaptor
15.	173/10HL	5/8" B.S.F. Locknut
16.	189AX118	Shear Pin Bush
17.	124/0428	1/8" Dia. Parallel Pin, 1.7/8" long
18.	189AX112	Push Rod Key
19.	189AX117A	Operating Plate
20.	189AX105A	6th Station Quadrant Link
21.	155/0412	1/4" B.S.F. Socket Head Cap Screw 3/4" long
22.	189AX125	Quadrant Link Pin
23.	NT/F204	5/8" B.S.F. Simmonds Locknut (Thin)
24.	130/10	5/8" Washer
25.	236/141608	Oil Retaining Bush
26.	NT/F204	5/8" B.S.F. Simmonds Locknut (Thin)
27.	130/10	5/8" Washer
28.	189AX130	Spring Anchor
29.	189AX124A	Return Spring
30.	236/161808	Oil Retaining Bush
31.	141X116	Slotted Washer
32.	173/10HL	5/8" B.S.F. Locknut
33.	137CX119	Tee Bolt
34.	189AX126A	Sliding Sleeve
35.	189AY101B	6th Station Quadrant Lever
36.	55/0520	5/16" B.S.F. Socket Head Cap Screw 1.1/4" long
37.	189AX106A	6th Station Scale
38.	165/204	2BA Round Head Screw 1/4" long
39.	125/1624	1/4" Dia. Taper Pin 1.1/2" long
40.	155/0616	3/8" B.S.F. Socket Head Cap Screw 1" long
41.	189AX116	Operating Lever Pivot
42.	189AV102B	6th Station Operating Lever
43.	125/1624	1/4" Dia. Taper Pin 1.1/2" long
44.	189AX132	Clamp
45.	155/0620	3/8" B.S.F. Socket Head Cap Screw 1.1/4" long
46.	155/0408	1/4" B.S.F. Socket Head Cap Screw 1/2" long

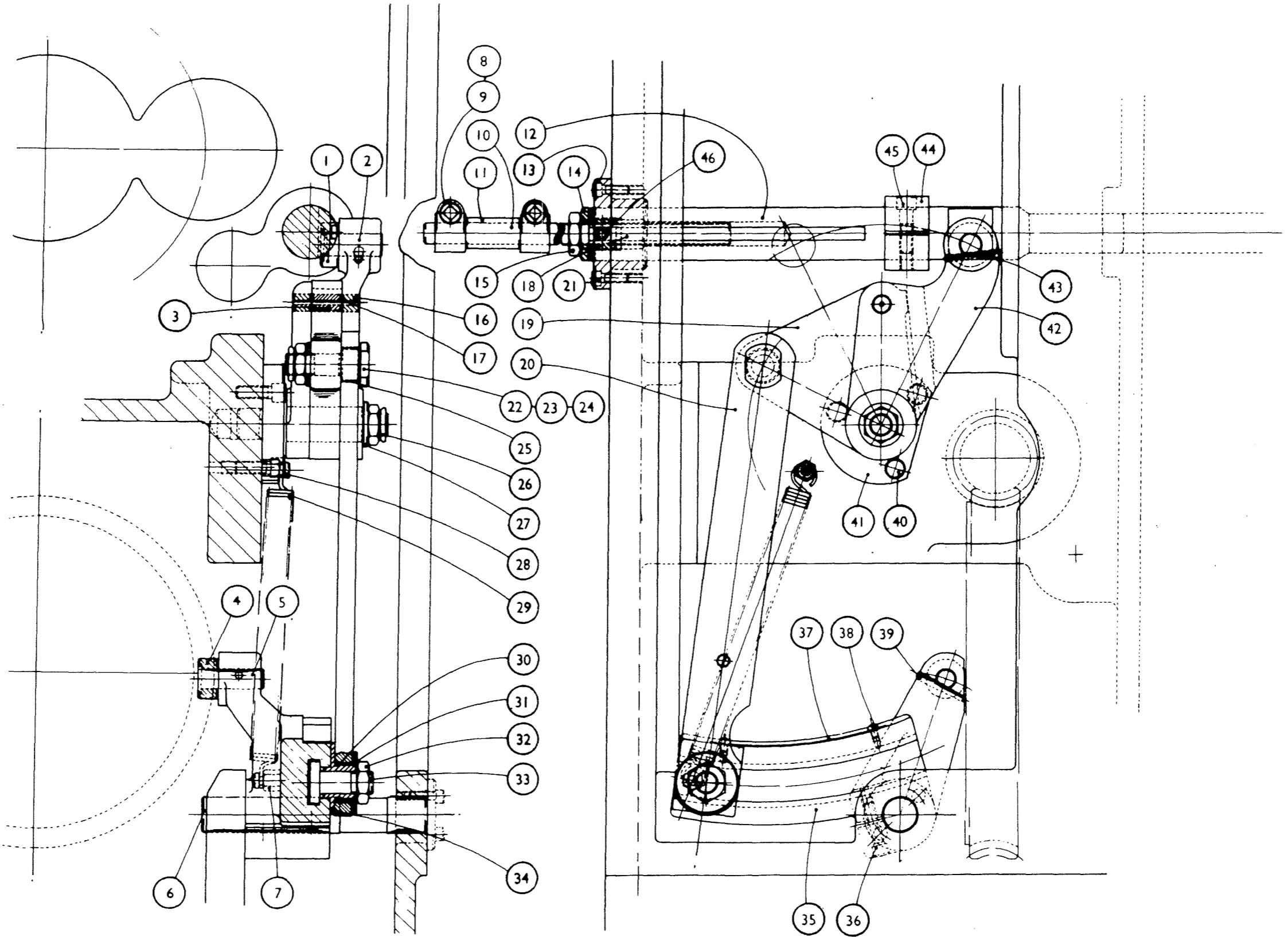

AUXILIARY LONGITUDINAL MOTION - STATION 6 SECTION 189A

1.	189AX132	Clamp
2.	155/0620	3/8" B.S.F. Socket Head Cap Screw 1.1/4" long
3.	189AY110A	Push Rod
4.	189BV102B	3rd Station Operating Lever
5.	189AX111	Push Rod Guide
6.	155/0412	1/4" B.S.F. Socket Head Cap Screw 3/4" long
7.	189AX113	Push Rod Adaptor
8.	173/10HL	5/8" B.S.F. Locknut
9.	189AX114	Push Rod Extension
10.	189AX131	Push Rod Bush
11.	150X129	Cam Roller Pin
12.	125/1624	1/4" Dia. Taper Pin 1.1/2" long
13.	150X130	Cam Roller
14.	189AX118	Shear Pin Bush
15.	124/0428	1/8" Dia. Parallel Pin 1.7/8" long
16.	189AX115	Push Rod Clamp
17.	195/0516H	5/16" B.S.F. Collet Head Screw (Naylot) 1" long
18.	155/0408	1/4" B.S.F. Socket Head Cap Screw 1/2" long
19.	189AX112	Push Rod Key
20.	189A117A	Operating Plate
21.	189BX106A	3rd Station Scale
22.	165/204	2BA Round Head Screw 1/4" long
23.	125/1624	1/4" Dia. Taper Pin 1.1/2" long
24.	189BX105A	3rd Station Quadrant Link
25.	189AX125	Quadrant Link Pin
26.	236/141608	Oil Retaining Bush
27.	130/10	5/8" B.S.F. Washer
28.	NT/F204	5/8" B.S.F. Simmonds Locknut (Thin)
29.	189AX129	Spring Anchor
30.	189BX123	Quadrant Pivot Pin
31.	155/0520	5/16" B.S.F. Socket Head Cap Screw 1.1/4" long
32.	189BY101B	3rd Station Quadrant Lever
33.	189AX126A	Sliding Sleeve
34.	236/161808	Oil Retaining Bush
35.	141X116	Slotted Washer
36.	173/10HL	5/8" B.S.F. Locknut
37.	137CX119	Tee Bolt
38.	189AX119A	Shear Pin Centre Bush
39.	189AX116	Operating Lever Pivot
40.	130/10	5/8" B.S.F. Washer
41.	NT/F204	5/8" B.S.F. Simmonds Locknut (Thin)
42.	155/0616	3/8" B.S.F. Socket Head Cap Screw 1" long
43.	189AX130	Spring Anchor
44.	189AX124A	Return Spring
45.	189AX120	Cam Roller
46.	189AX121	Cam Roller Pin

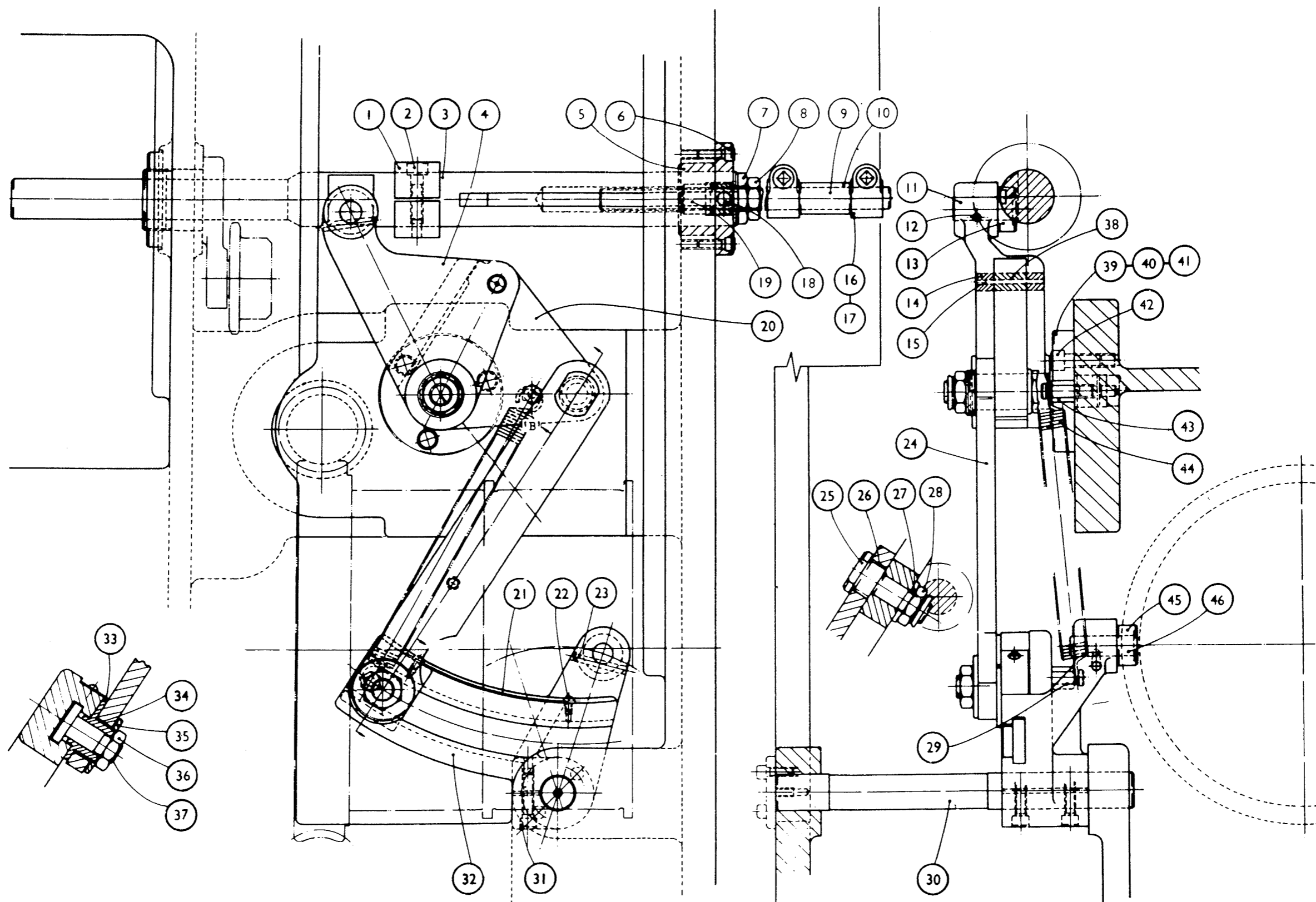

AUXILIARY LONGITUDINAL MOTION - STATION 3 SECTION 189B

189BZ1A

Drg No. 190V2A Drilling Drive, - Section 190B: Station 3

1.	155/0412	1/4" B.S.F. Socket Head Cap Screw 3/4" long
2.	154/04	1/4" Dia. Spring Washer
3.	190X126	Adjusting Plate
4.	190V130	Drive Bracket
5.	104/33	62mm Internal Circlip
6.	190X134	Idler Gear Pin
7.	190X135	Idler Spacer
8.	104/21	35mm Internal Circlip
9.	190X132	Driving Gear
10.	265/15	15mm Double Row Ball Journal
11.	104/21	35mm Internal Circlip
12.	203/07L	7/16" B.S.F. Self Locking Hexagon Locknut
13.	190X136	Washer
14.	190X133	Idler Gear
15.	22/1014T	5/16" x 7/32" Parallel Key 7/8" long
16.	151/36	30mm Slotted Locknut
17.	176/0405	1/4" B.S.F. Hollow Set Screw 5/16" long. cup point
18.	153/04	1/4" Dia. Copper Pad
19.	188/0520	5/16" B.S.F. Square Head Set Screw 1.1/4" long
20.	190X131	Driven Gear
21.	258/30	30mm Light Ball Journal;
22.	190X110	Outer Spacer
23.	190X109	Inner Spacer
24.	154/05	5/16" Dia. Spring Washer
25.	155/0514	5/16" B.S.F. Socket Head Cap Screw 7/8"
26.	258/30	30mm Light Ball Journal
27.	190X108	Drive Sleeve
28.	190X125	Clamp Plate

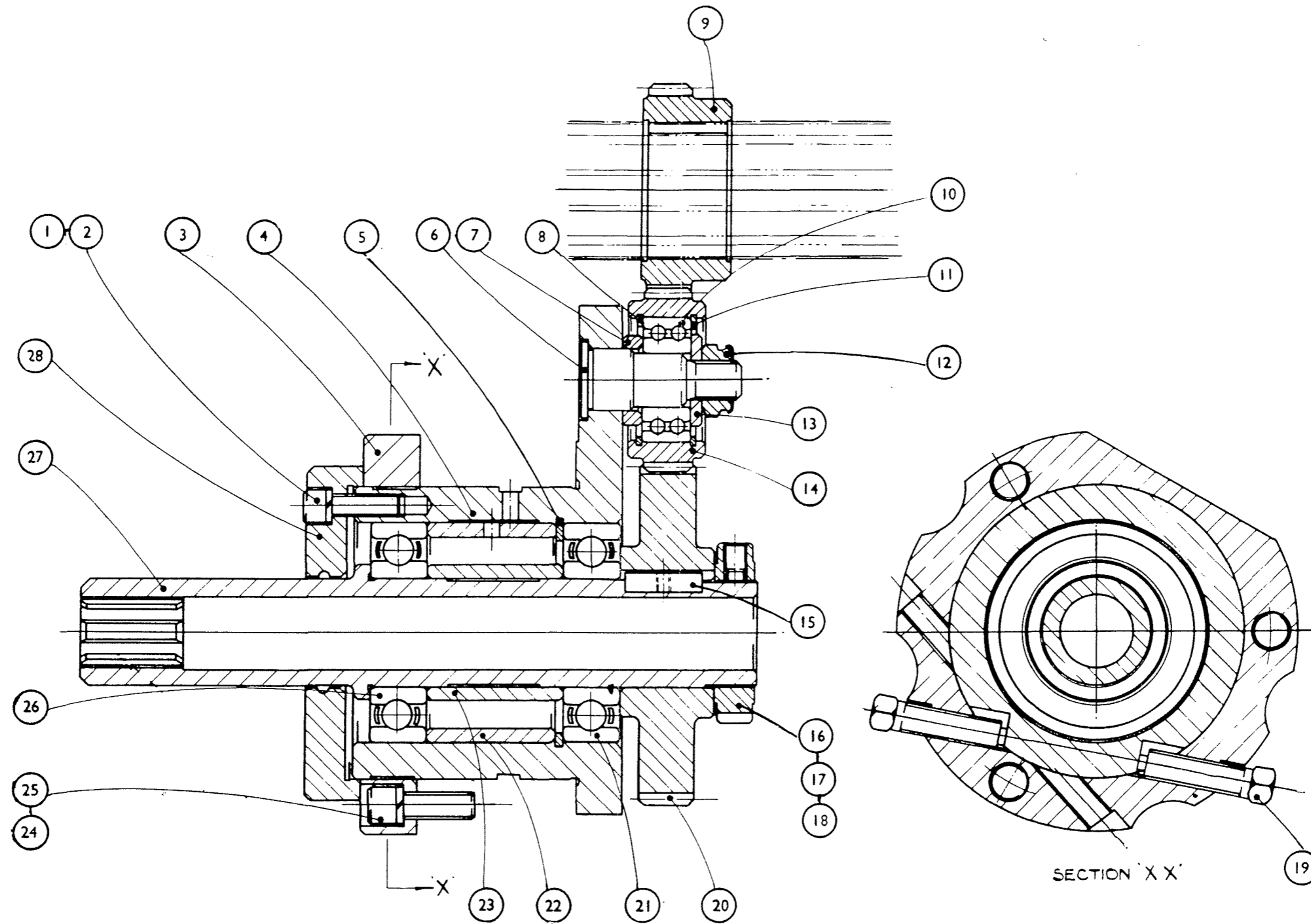

DRILLING DRIVE SECTION 190B

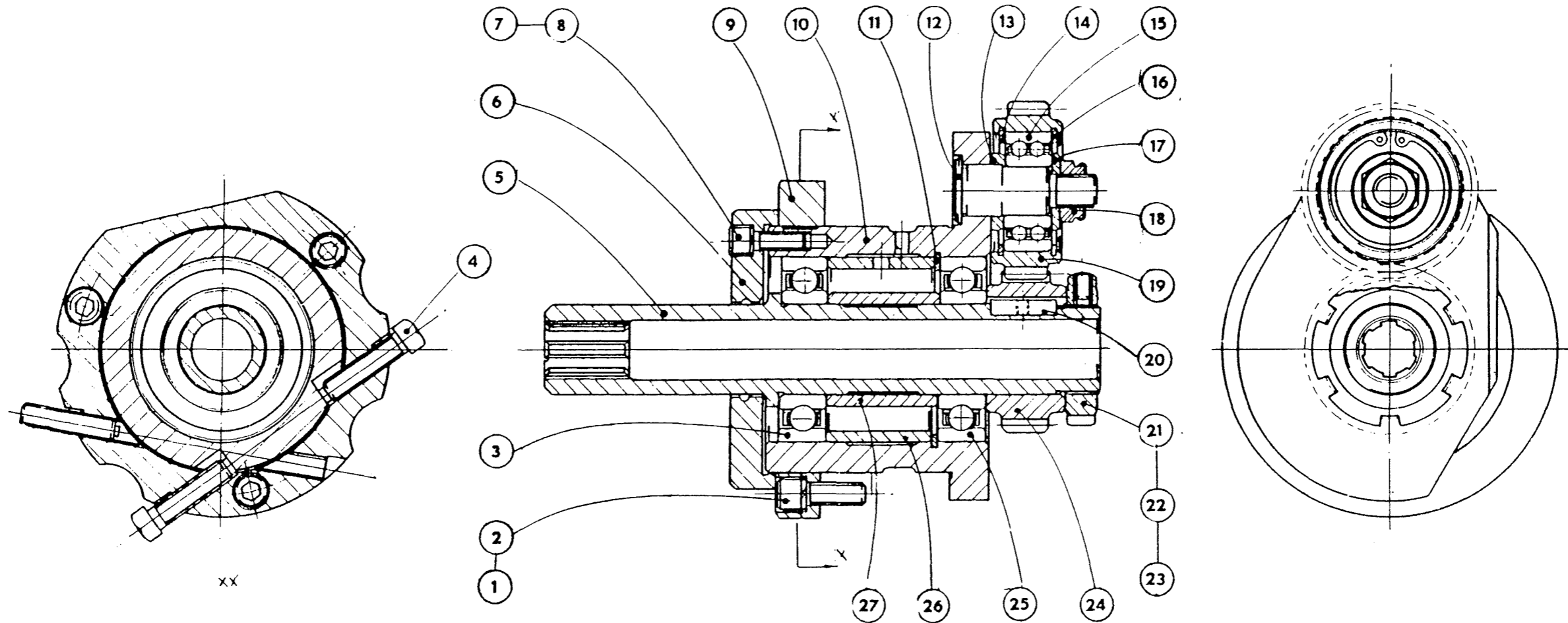

HIGH SPEED DRILLING DRIVE

Drg.190Y3

Drg No. 190V4 ----- High Speed Drilling Spindle - Section 190G

1. 190X120 Collet Nut
2. 190X119 Thrower Ring
3. 156/210 2BA Socket Head Cap Screw 5/8" long
4. 190X118 Binding Cap
5. 5B21 Light Metric Angular Contact Bearing
25 x 52 x 15mm
6. 212/04 1/4" B.S.F. Autolub Nipple
7. 210/1725 1/4" Dia. Yellow Plastic Washer
8. 153/42 Soft Pad
9. 179/204 2BA Socket Set Screw 1/4" long
10. 151/25 25mm Slotted Locknut
11. 190X123 Adjusting Nut
12. 190X121 Adjusting Collar
13. 124/0822 1/4" Dia. Parallel Pin - Soft 1.3/8" long
14. 190X123 Adjusting Nut
15. 190Y104 High Speed Drilling Spindle
16. 190V117A Housing
17. 190X122 Adjusting Rod

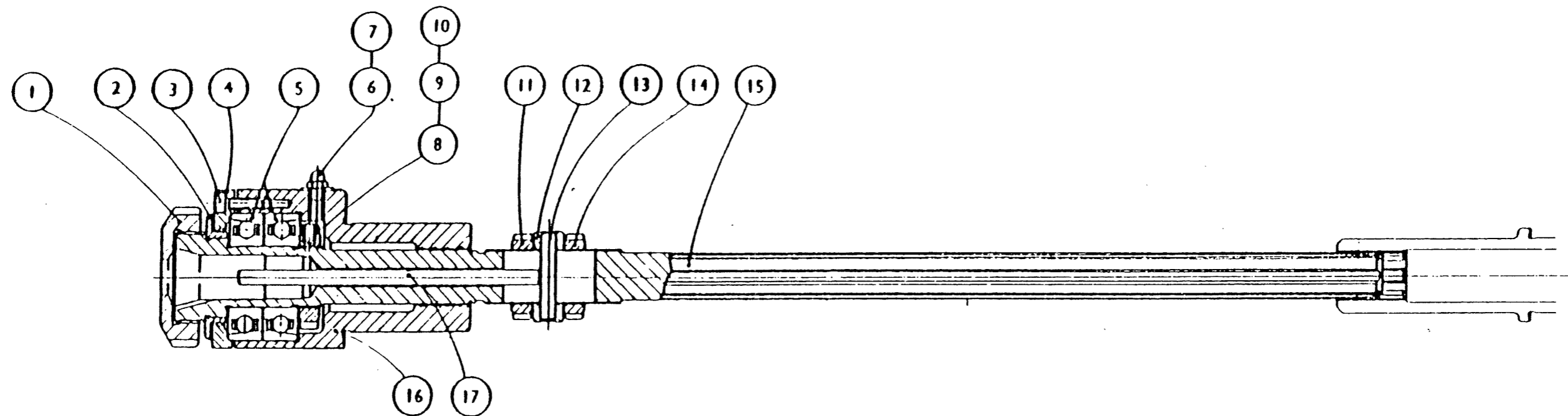

HIGH SPEED DRILLING SPINDLE SECT. 190 G

Drg No. 190V5A Synchronous Drive Attachment - Section 190J

- | | | |
|-----|-----------|--------------------------------------|
| 1. | 190X142 | Drive Sleeve |
| 2. | 190X144 | Bearing Nut |
| 3. | 155/0514 | 5/16" BSF Cap Screw x 7/8" |
| 4. | 154/05 | 5/16" Spring Washer |
| 5. | 258/35 | Ball Bearing 35mm x 72mm x 17mm wide |
| 6. | 190X143 | Bearing Spacer |
| 7. | 190V141 | Housing |
| 8. | 258/35 | Ball Bearing 35mm x 72mm x 17mm wide |
| 9. | 190X145 | Gear Spacer |
| 10. | 122/1228T | Key 3/8" x 1/4" x 1.3/4" long |
| 11. | 150/22 | Locknut 1.3/8" x 22 T.P.I. |
| 12. | 153/04 | Copper Pad |
| 13. | 176/0405 | 1/4" BSF Set Screw x 5/16" long |

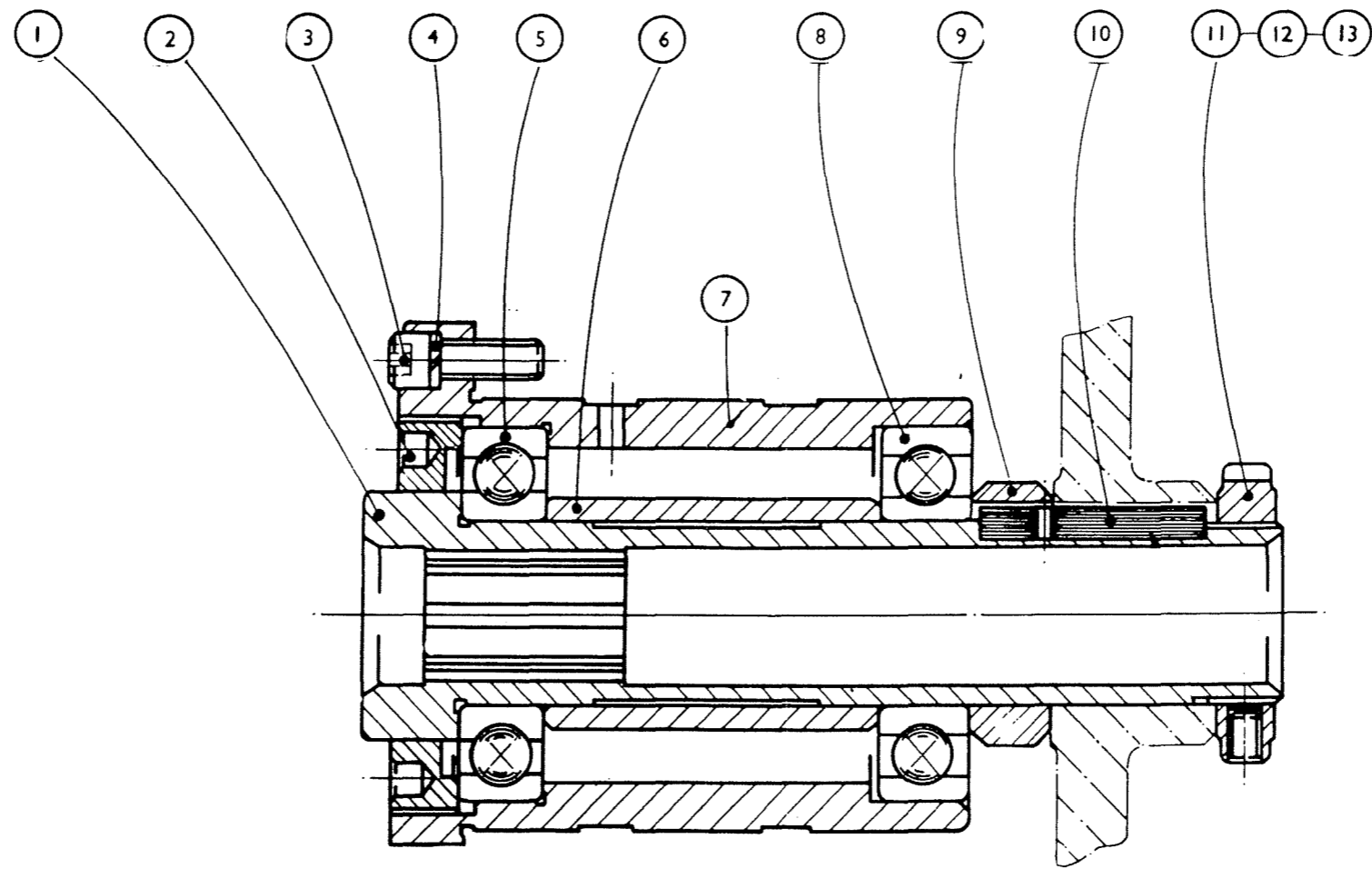

SYNCHRONOUS DRIVE ATTACHMENT

190 V 5 A

Drg No.190Y12 High Speed Drilling Spindle. Sec.190M

1. 190X119 Thrower Ring
2. 156/210 2BA Screw x 5/8" long
3. 190X118 Binding Cap
4. SBZ1 Light Metric Angular Contact
5. 212/045 1/4 B.S.F. Nipple
6. 210/1725 Yellow Washer
7. 151/25 25mm Slotted Nut
8. 179/204 2BA Screw 1/4" long
9. 153/42 Soft Pad
10. 190Y103 High Speed Drilling Spindle
11. 190V117A Housing
12. 30021 Bristol Erickson Stop Screw (Item 7)
13. Bristol Erickson Collet 100 Series
14. 13-000-109-1 Bristol Erickson Std. Lock Nut
15. 13-020-109-1 Bristol Erickson Nose Ring Clip
16. 13-010-109-1 Bristol Erickson Nose Ring

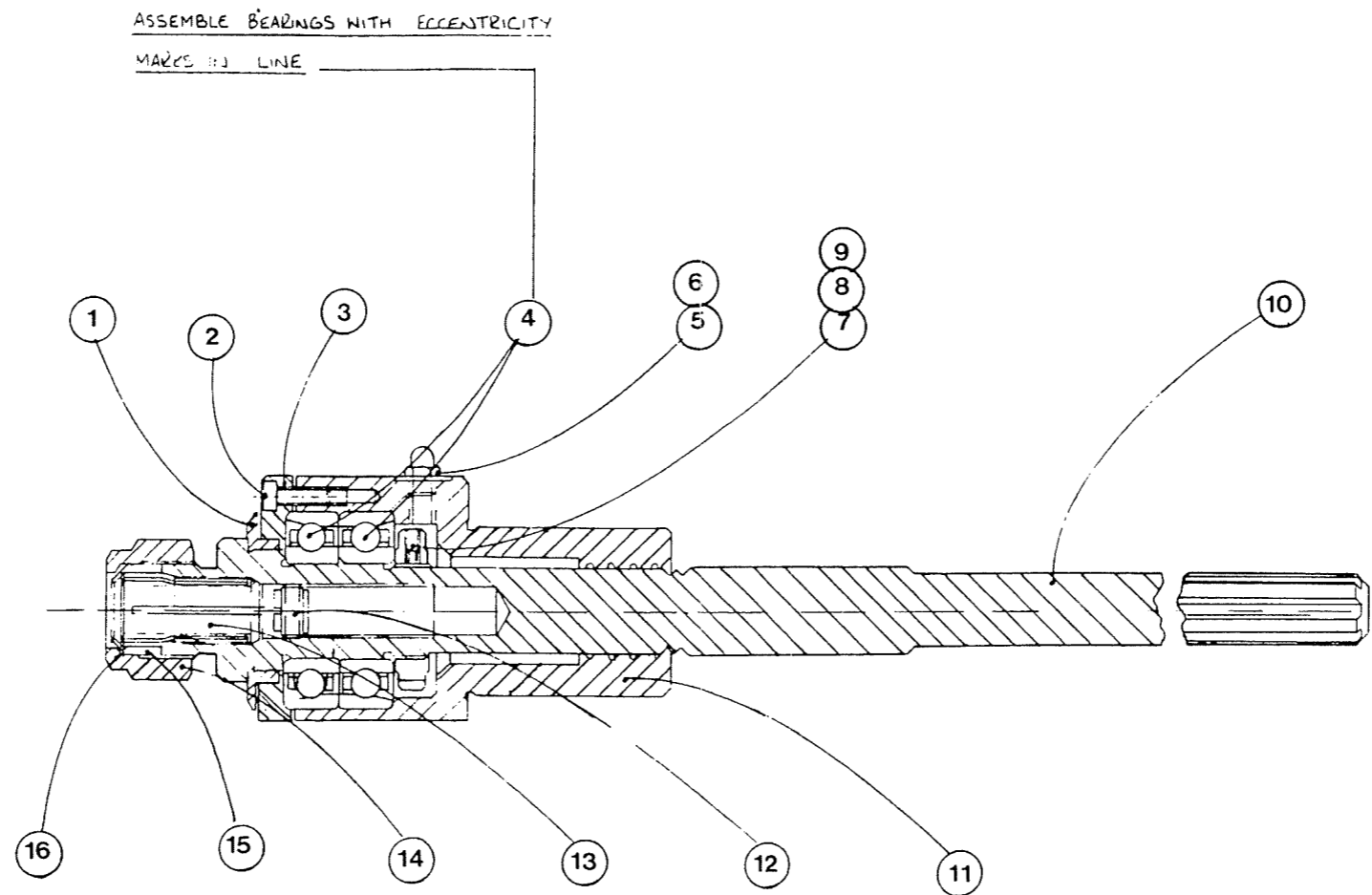

SUPPLIED BY TOOLING TO
SUIT DRILL (MAX CAPACITY
1/2 THRD BACKSTOP TAPPED HOLE)

FIRST USED ON BATCH
LAST USED ON BATCH
DATE
190V4
ISSUED 100A657 LTR FEB 89

Wickman MACHINE TOOL DIVISION
COVENTRY - ENGLAND

COPYRIGHT

DESCRIPTION
HIGH SPEED DRILLING SPINDLE SECTION 190M

SCALE	DRAWN	L.R.	9.1.89	MATERIAL	SEE LOP 190L3	190M	1.8	190Y12
FULL SIZE	CHECKED							
	TRACED							
	TEMPING							
	CHECKED							

Drg. 190Y10B

DISTANCE TO SPINDLE NOSE
 MAXIMUM 12' 32"
 MINIMUM 1' 7/64"

HIGH SPEED DRIVE
 SEC. 190H.

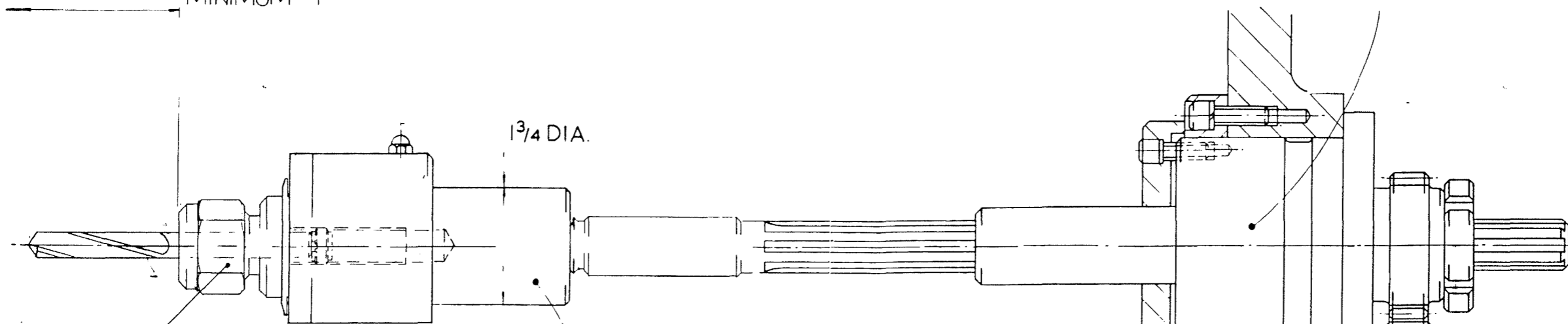

BRISTOL ERICKSON COLLET 100 SERIES
 MAXIMUM CAPACITY 1/2"
 FOR FULL RANGE OF COLLETS AVAILABLE SEE SMD 100

1 3/4 DIA.
 HIGH SPEED DRILLING SPINDLE
 SEC 190M

DRIVE FITTED WITH
 2·8/1 RATIO.

2·8/1 RATIO CANNOT BE FITTED
 IN THE NEXT STATION FOLLOWING
 A THREADING DRIVE
 FLAT GENERATING OR
 PICK-UP ATTACHMENT.

ADJUST SCREWS TO
 GIVE .005 BACKLASH
 IN GEARS.

3RD. & 6TH STATION.
 USE SOCKET SET
 SCREW SUPPLIED WHEN
 USED WITH AUX.
 LONGITUDINAL MOTION.

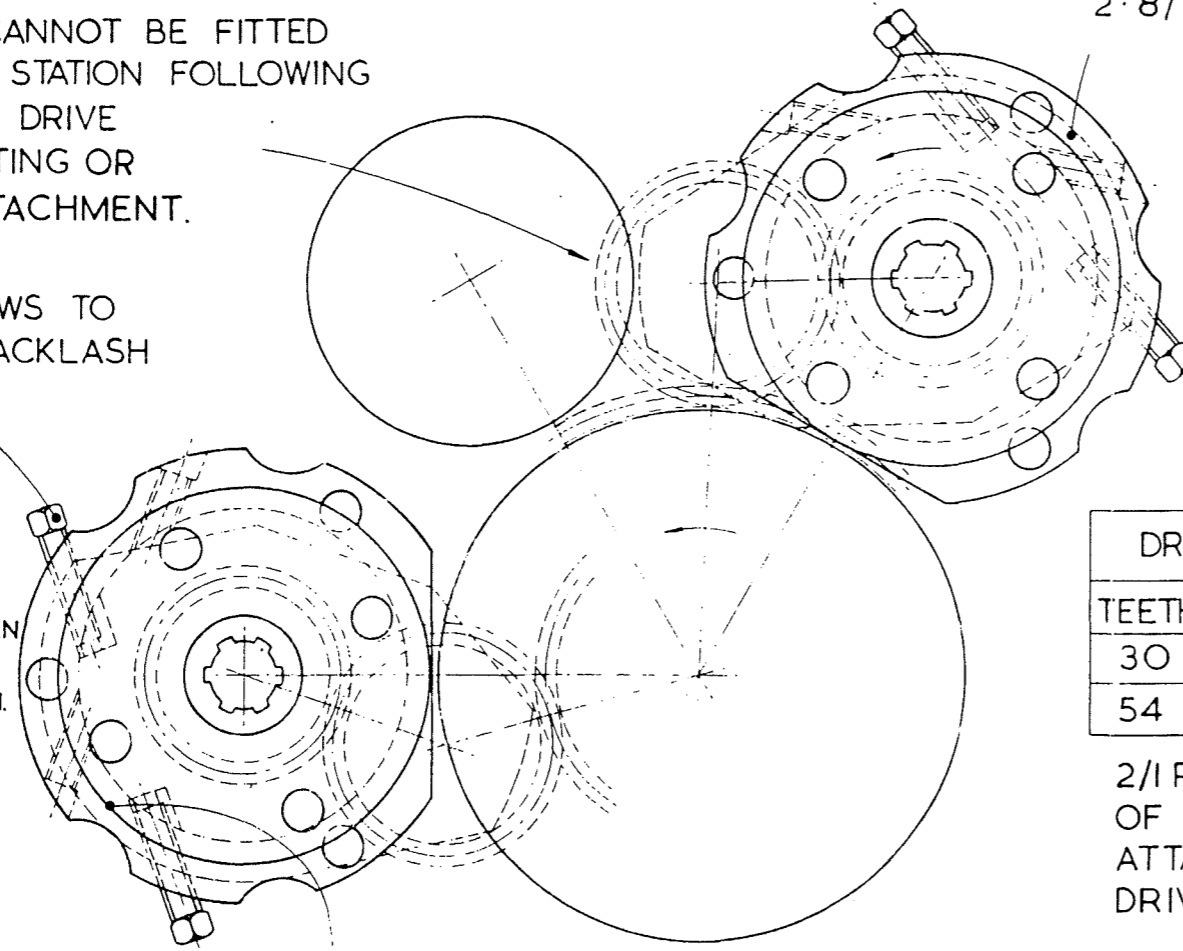

DRIVE FITTED WITH 2/1 RATIO.

DRIVING GEAR		RATIO STANDARD MACHINE	RATIO SPINDLE STOPPING M/C.
TEETH	REFERENCE		
30	181D X 101/30	2/1	2·13/1
54	181D X 101/54	2·8/1	3·03/1

2/1 RATIO MEANS THAT THE RELATIVE SPEED
 OF DRILL TO WORK IS TWICE THE SPINDLE SPEED.
 ATTACHMENTS FITTED CONCURRENTLY MUST BE
 DRIVEN AT THE SAME RATIO.

FIRST USED ON
LAST USED ON
SUPERSEDES 190Y10A
SUPERSEDED BY
ALTERATION
SS 100A 657 L RICKARDS 15.7.53
U & B LIMIT HOLES AS B.S. 164:1941.
REMOVE ALL SHARP CORNERS UNLESS OTHERWISE STATED.
TOLERANCE ON MACHINING DIMENSIONS AS SHOWN UNLESS OTHERWISE STATED.
AMERICAN PROJECTION
RF - ROUGH MACHINE FF - FINISH MACHINE FF - GRIND OR EQUIVALENT
RAW MATERIAL NO.
MARK Dwg. No. AT
DRG. No. 190Y10B

WICKMAN MACHINE TOOL MANUFACTURING CO. LTD.

COVENTRY ENGLAND

DESCRIPTION
 HIGH SPEED DRILLING ATTACHMENT.
 APPLICATION DRAWING

SCALE: FULL SIZE	DRAWN: LJR 14289	MATERIAL
	CHECKED	
	TRACED	
	CHECKED	

ARR 13	30M.H	1"·6
No. OFF	DWG. NO.	SECTION MACHINE

Drg No. 192Z1B Chasing Attachment MK.III - Section 192

1.	155/0620	3/8" B.S.F. Hexagon Socket Head Cap Screw 1.1/4" long
2.	130/06	3/8" Dia. Flat Washer
3.	176/0405	1/4" B.S.F. Hexagon Socket Set Screw, Cup Point 5/16" long
4.	153/42	Brass Pad
5.	179/204	2BA Hexagon Socket Set Screw, Cup Point 1/4" long
6.	150/10	5/8" Dia. Slotted Locknut 22 T.P.I.
7.	258/17	Light Ball Journal 17mm bore
8.	192X102	End Cap
9.	155/0410	1/4" B.S.F. Hexagon Socket Head Cap Screw 5/8" long
10.	154/04	Lock Washer
11.	192X125	Spacer
12.	192BY151	Standard Lead Cams
13.	192X126	Camshaft
14.	192BX103	Relief Cam
15.	192V150A	Relief Cam
16.	192X130	Driven Gear
17.	154/04	Lock Washer
18.	155/0412	1/4" B.S.F. Hexagon Socket Head Cap Screw 3/4" long
19.	SB58	Light Ball Journal, Ang. Contact. 17mm bore
20.	155/0412	1/4" B.S.F. Hexagon Socket Head Cap Screw 3/4" long
21.	154/04	Lock washer
22.	203/08	Locknut
23.	130/08	1/2" Dia. Flat Washer
24.	192X103	Thrust Cap
25.	SB58	Light Ball Journal, Ang. Contact 17mm bore
26.	192X128	Inner Spacer
27.	192X127	Drive Shaft
28.	192X104	End Cap
29.	121/0824	Square Key 1/4" sq. x 1.1/2" long
30.	203/08	Locknut
31.	130/08	1/2" Dia. Flat Washer
32.	121/0610	Square Key 3/16" sq. x 5/8" long
33.	192X131	Driving Gear
34.	192X129	Outer Spacer
35.	173/05	5/16" B.S.F. Hexagon Nut
36.	182/0516	5/16" B.S.F. Hexagon Socket Set Screw, Taper Point, 1" long
37.	155/0412	1/4" B.S.F. Hexagon Socket Head Cap Screw 3/4" long
38.	154/04	Lock Washer
39.	192X106A	Cover Plate
40.	155/0410	1/4" B.S.F. Hexagon Socket Head Cap Screw 5/8" long
41.	192Z101B	Main Body
42.	210/1725	9/16" Dia. Washer
43.	212/9004	1/4" B.S.F. Grease Nipple
44.	210/1725	9/16" Dia. Washer
45.	212/04	1/4" B.S.F. 'Autolub' Nipple
46.	210/1725	9/16" Dia. Washer
47.	212/04	1/4" B.S.F. 'Autolub' Nipple
48.	130/06	3/8" Dia. Flat Washer
49.	167/0620H	3/8" B.S.F. Hexagon Head Set Screw, 1.1/4" long
50.	173/05L	Hexagon Locknut
51.	188/0520	5/16" B.S.F. Square Head Set Screw 1.1/4" long
52.	154/05	Lock Washer
53.	155/0512	5/16" B.S.F. Hexagon Socket Head Cap Screw 3/4" long
54.	192X119	Adjustment Strip
55.	165/404	4BA Round Head Set Screw 1/4" long

56.	192X146	Lubrication Plate
57.	212/04	1/4" B.S.F. 'Autolub' Nipple
58.	210/1725	9/16" Dia. Washer
59.	173/04L	Hexagon Locknut
60.	182/0412	1/4" B.S.F. Hexagon Socket Set Screw, Taper Point, 3/4" long
61.	192X105A	Oil Cover
62.	192X161	Stop
63.	156/408	4BA Hexagon Socket Head Cap Screw 1/2" long
64.	154/4	Lock Washer
65.	155/0672	3/8" B.S.F. Hexagon Socket Head Cap Screw 4.1/2" long
66.	192X110	Relief Roller Pin
67.	192X111	Relief Roller
68.	192X121	Spring Cap
69.	192X122	Lead Spring
70.	192X120	Spring Plunger
71.	192X123	Thrust Pad
72.	192X109	Slide Shaft
73.	192X132	T-Nut
74.	192Y107	Slide
75.	192X108	Slide Bush
76.	182/0408	1/4" B.S.F. Hexagon Socket Set Screw, Taper Point 1/2" long
77.	192X147	Plug
78.	192X114	Spring Anchor
79.	182/0408	1/4" B.S.F. Hexagon Socket Set Screw, Taper Point, 1/2" long
80.	192X159	Plug
81.	192X115	Tension Spring
82.	192X116	Spring Adjuster
83.	143/0808A	1/4" Dia. Grooved Pin, 1/2" long, Type A
84.	192X117	Collar
85.	173/08	1/2" B.S.F. Hexagon Nut
86.	173/08L	Hexagon Locknut
87.	192X142A	Oil Pipe
88.	182/0408	1/4" B.S.F. Hexagon Socket Set Screw, Taper Point, 1/2" long
89.	192X113	Lead Roller Pin
90.	192X143	Thrust Washer
91.	124/0205	1/16" Dia. Parallel Dowel x 5/16" long
92.	192X112	Lead Roller
93.	192X118A	Locator
94.	192X160	Oil Pipe
95.	192X145	Oil Feeder

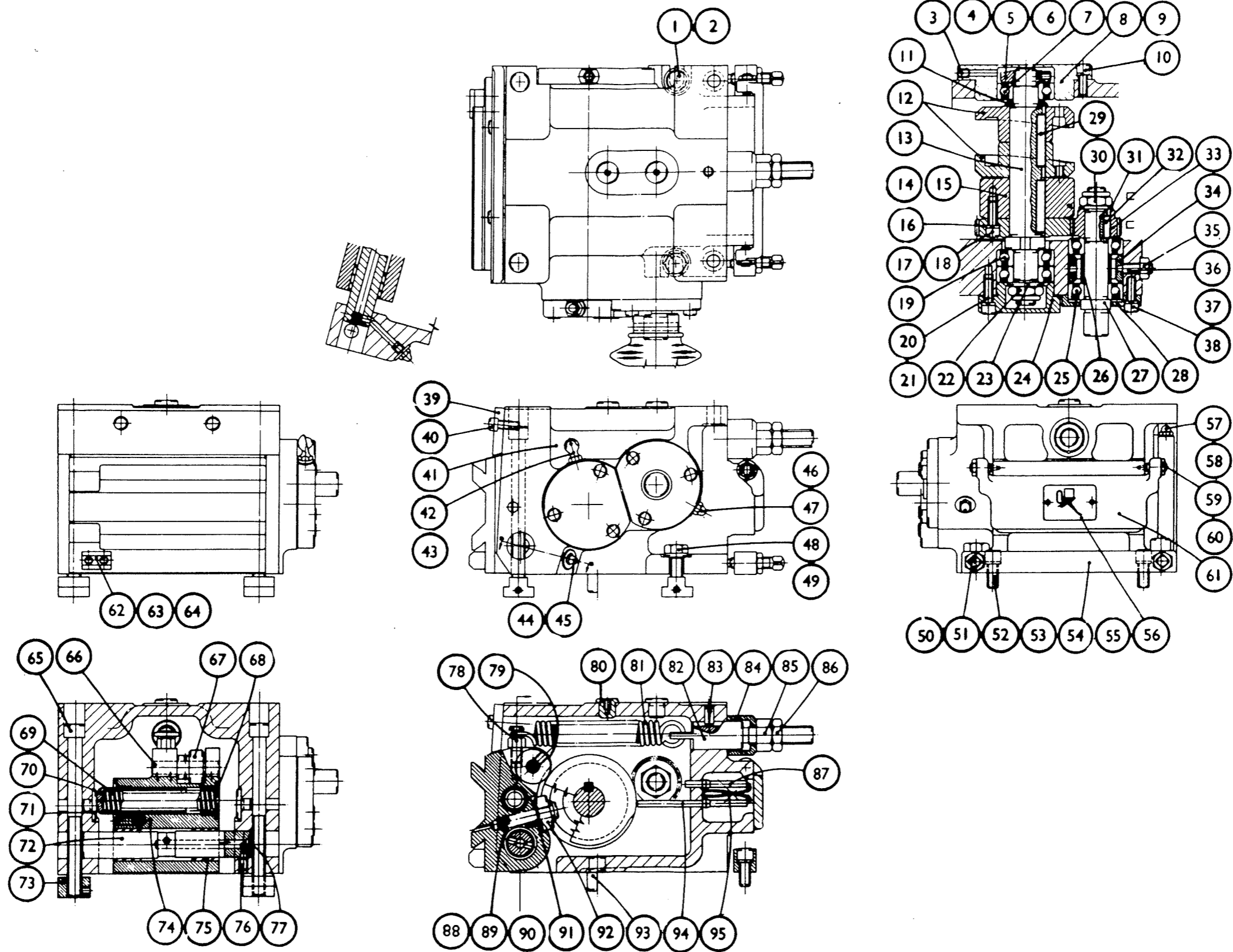

CHASING ATTACHMENT MK.III SECTION 192

Drg No. 192AZ1A Chasing Attachment MK.II Drive - Section 192A

1.	-	Ball Type Universal Joint No. 3 with cover.
2.	125/1622	Taper Pin 1/4" Dia. x 1.3/8" long
3.	192AX133	Drive Sleeve
4.	192AX132	Coupling Shaft Spring
5.	192AX119	Drive Shaft
6.	192AX120	Drive Pin
7.	125/1622	Taper Pin 1/4" Dia. x 1.3/8" long
8.	192X139A	Clamp Nut
9.	326/0306	Tension Pin 3/32" Dia., 3/8" long
10.	192X140	Clamp Bolt
11.	192X134	Clamp Bolt
12.	192X135A	Adjusting Gear
13.	192X138A	Clamp Bush
14.	173/07H	7/16" B.S.F. Hexagon Nut
15.	155/0410	1/4" B.S.F. Socket Head Cap Screw x 3/8" long
16.	154/04	Spring Lock Washer, 1/4" Dia. x
17.	192X137	Clamp
18.	124/0414	Pin 1/8" Dia. x 7.8" long
19.	192X136A	Adjusting Worm
20.	192X133A	Chaser Bracket
21.	188/0452	1/4" B.S.F. Square Head Set Screw x 3.1/4" long
22.	176/0406	1/4" B.S.F. Hexagon Socket Set Screw Cup Point 3/8" long
23.	153/04	Soft Pad
24.	-	Mollart Universal Ball Joint No. 3 with Cover
25.	125/1622	Taper Pin 1/4" Dia. x 1.3/8" long
26.	263/20	Light Metric Angular Contact 20mm x 47mm x 14mm.
27.	192AX105	End Cap
28.	156/208	2BA SDocket Head Cap Screw x 1/2" long
29.	121/0816T	Square Key Tapped 1/4" sq. x 1" long
30.	192AX109	Driven Gear
-	192BX102	Driven Gear
31.	156/208	2BA Socket Head Cap Screw x 1/4" long
32.	192AX122	End Cover
33.	192AX111	Final Shaft
34.	263/20	Angular Contact Ball Journall 20mm x 47mm x 14mm.
35.	156/208	2BA Socket Head Cap Screw x 1/2" long
36.	192AX103	End Cover
37.	263/20	Angular Contact Ball Journal 20mm x 47mm x 14mm
38.	121/0816T	Square Key Tapped 1/4" sq. x 1" long
39.	192AX112	Intermediate Shaft
40.	192AX110	Driving Gear
-	192BX101	Driving Gear
41.	258/20	Light Type Ball Journal, 20mm x 47mm x 14mm
42.	192AX104	Location Bush
43.	192AX121	Spacer
44.	192AY101	Drive Box
45.	192AX115A	Driven Sprocket
46.	121/0614T	Square Key Tapped 3/16" sq. x 7/8" long
47.	192AX114	Washer
48.	203/07L	7/16" B.S.F. Self Locking Nut (Thin)
49.	156/208	2BA Socket Head Cap Screw x 1/2" long
50.	192AX108	Bearing Housing
51.	263/20	Angular Contact Ball Journal, 20mm x 47mm x 14mm.
52.	203/07L	7/16" B.S.F. Self-locking Nut (Thin)
53.	192AX114	Washer
54.	121/0814T	Square Key Tapped 1/4" sq. x 7/8" long

55.	-	See Table on Drawing 192AZ1A
56.	203/07L	7/16" B.S.F. Self-locking Nut (Thin)
57.	192AX114	Washer
58.	192AV106A	Gear Cover
59.	-	See Table on Drawing 192AZ1A
60.	192AX107	Clamp Ring
61.	156/208	2BA Socket Head Cap Screw x 1/2" long
62.	258/20	Light Metric Ball Journal, 20mm x 47mm x 14mm
63.	192AX113A	Drive Shaft
64.	154/05	Spring Lock Washer 5/16" dia.
65.	155/0516	5/16" B.S.F. Socket Head Cap Screw x 1" long
66.	156/212	2BA Socket Head Cap Screw x 3/4" long
67.	154/03	Spring Lock Washer 3/16" dia.
68.	155/0416	1/4" B.S.F. Socket Head Cap
69.	154/04	Spring Lock Washer 1/4" dia.
70.	192AX117A	Clamp Ring
71.	192AX116A	Jockey Carrier
72.	203/04	1/4" B.S.F. Self-locking Nut
73.	182/0414	1/4" B.S.F. Hexagon Socket Set Screw, Taper Point, 7/8" long
74.	192AX118A	Jockey Pin
75.	-	Renold Pinion 212013, 1" bore.
76.	236/121618	Oil Retaining Bush, 3/4" Bore, 1" outside diameter, 1.1/8" long
77.	-	Renold Chain No. 110038 (69 Pitches)
78.	155/0540	5/16" B.S.F. Socket Head Cap Screw x 2.1/2" long
79.	154/05	Spring Lock Washer, 5/16" dia.
80.	156/210	2BA Socket Head Cap Screw x 5/8" long
81.	154/03	Spring Lock Washer 3/16" dia.
82.	192AX102	Top Cover
83.	-	Rotherham Sight Feed Lubricator No. 0.
84.	154/03	Spring Lock Washer 3/16" Dia.
85.	156/228	2BA Socket Head Cap Scew x 1.3/4" long

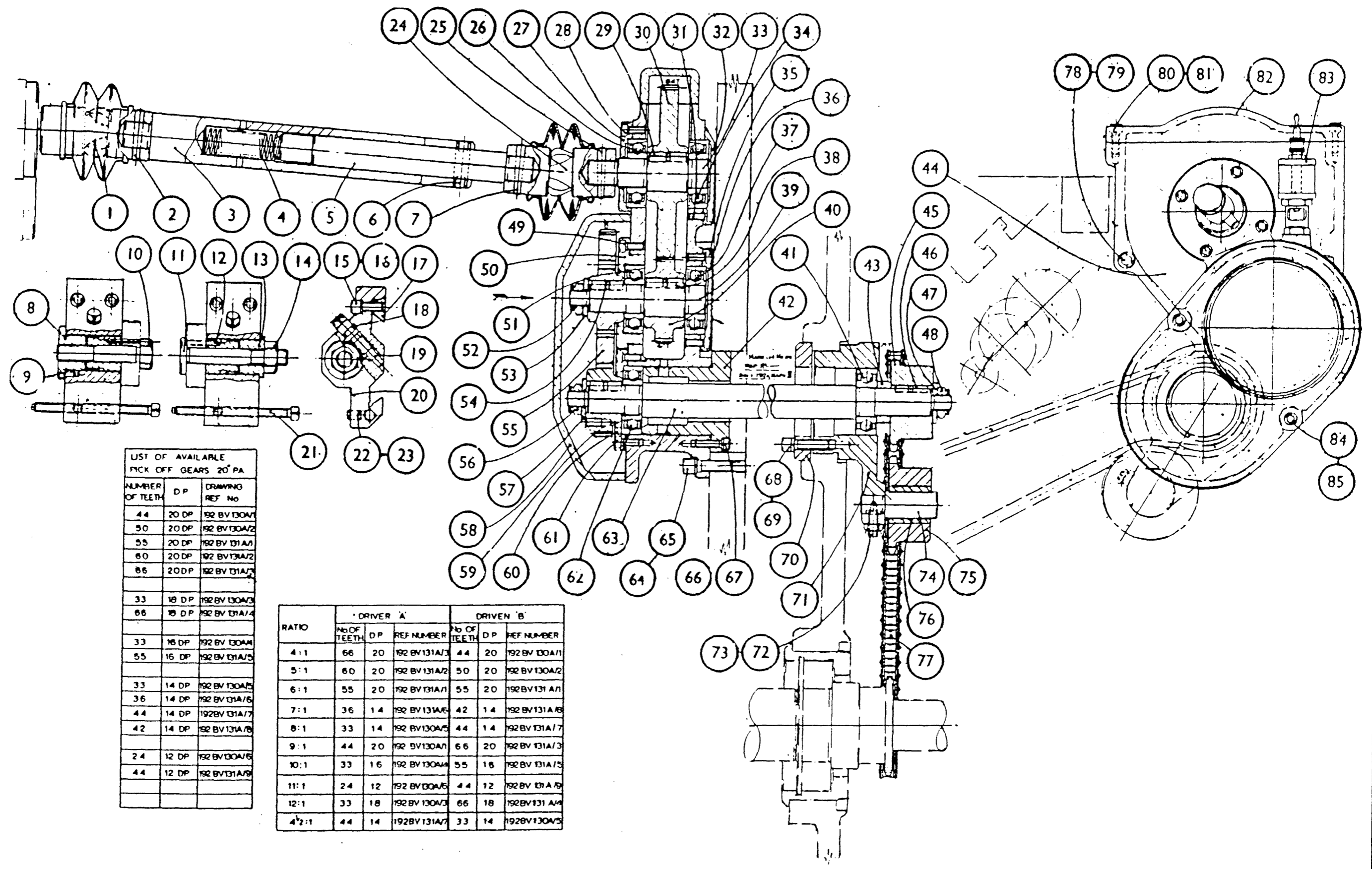

LIST OF AVAILABLE PICK OFF GEARS 20° PA

NUMBER OF TEETH	D.P.	DRAWING REF. No
44	20 DP	192 BV 130A/1
50	20 DP	192 BV 130A/2
55	20 DP	192 BV 131A/1
60	20 DP	192 BV 131A/2
66	20 DP	192 BV 131A/3
33	18 DP	192 BV 130A/3
66	18 DP	192 BV 131A/4
33	16 DP	192 BV 130A/1
55	16 DP	192 BV 131A/5
33	14 DP	192 BV 130A/5
36	14 DP	192 BV 131A/6
44	14 DP	192 BV 131A/7
42	14 DP	192 BV 131A/8
24	12 DP	192 BV 130A/6
44	12 DP	192 BV 131A/9

RATIO	DRIVER 'A'			DRIVEN 'B'		
	No OF TEETH	D.P.	REF NUMBER	No OF TEETH	D.P.	REF NUMBER
4:1	66	20	192 BV 131A/3	44	20	192 BV 130A/1
5:1	60	20	192 BV 131A/2	50	20	192 BV 130A/2
6:1	55	20	192 BV 131A/1	55	20	192 BV 131 A/1
7:1	36	14	192 BV 131A/6	42	14	192 BV 131A/8
8:1	33	14	192 BV 130A/5	44	14	192 BV 131A/7
9:1	44	20	192 BV 130A/1	66	20	192 BV 131A/3
10:1	33	16	192 BV 130A/4	55	16	192 BV 131A/5
11:1	24	12	192 BV 130A/6	44	12	192 BV 131A/9
12:1	33	18	192 BV 130A/3	66	18	192 BV 131 A/4
4 1/2:1	44	14	192 BV 131A/7	33	14	192 BV 130A/5

CHASING ATTACHMENT MK.II SECTION 192A

192 AZ 1A

1.	192AX102	Top Cover
2.	WSP154/03	3/16" dia. Spring Washer
3.	WSP156/210	2BA Cap Screw x 5/8" long
4.	192Z201	Drive Box
5.	O No.	Sight Feed Lubricator 3/8" B.S.P.
6.	WSP156/228	2BA Cap Screw 1.3/4" long
7.	WSP154/03	3/16" dia. Spring Washer
8.	WSP155/0540	5/16" B.S.F. Cap Screw x 2.1/2" long
9.	WSP154/05	5/16" Spring Washer
10.	Mollart No.3	Ball Type Universal joint with Cover
11.	WSP125/1622	1/4" dia. Taper Pin x 1.3/8" long
12.	192AX132	Coupling Shaft Spring
13.	192AX133	Drive Sleeve
14.	192X214	Drive Shaft
15.	192AX120	Drive Pin
16.	WSP125/1622	1/4" dia. Taper Pin x 1.3/8" long
17.	Mollart No.3	Ball Type Universal Joint with Cover
18.	192AX105	End Cap
19.	WSP156/208	2BA Cap Screw 1/2" long
20.	192AX111	Final Shaft
21.	192BX102	Driven Gear 1"-6S only
22.	192AX109	Driven Gear
23.	WSP262/20	Light Metric Ball Journal 20 x 47 x 14mm
24.	192AX122	End Cover
25.	WSP121/0816T	Square Key Tapped 1/4" sq. x 1" long
26.	WSP156/208	2BA Cap Screw 1/2" long
27.	192AX110	Driving Gear
28.	192BX10T	Driving Gear - 1"-6S only
29.	192AX103	End Cover
30.	WSP263/20	Light Metric Angular Contact 20 x 47 x 14mm
31.	WSP121/0816T	Sq. Key Tapped 1/4" sq. x 1" long
32.	192AX112	Intermediate Shaft
33.	WSP156/208	2BA Cap Screw 1/2" long
34.	192X210	End Cover
35.	WSP153/05	Soft Pad for 5/16" B.S.F.
36.	WSP176/0506	5/16" B.S.F. Set Screw Cup x 3/8" long
37.	192X204	Driven Gear
38.	WSP121/0816T	Sq. Key Tapped 1/4" sq. x 1" long
39.	192AX114	Washer
40.	WSP203/07L	Self Lock Nut, thin 7/16" B.S.F.
41.	WSP156/208	2BA Cap Screw x 1/2" long
42.		Pick-off gear as required
43.	WSP121/0804T	Sq. Key Tapped 1/4" sq. x 7/8" long
44.	192V202	Gear Cover
45.	192X211	Bearing Housing
46.	WSP203/07L	Self Lock Nut, thin 7.16" B.S.F.
47.	WSP121/0814T	Sq. Key Tapped 1/4" sq. x 7/8" long
48.	192AX114	Washer
49.	192AX112	Intermediate Shaft
50.	WSP258/20	Light Metric Ball Journal 20 x 47 x 14mm
51.		Pick-off gear as required
52.	192X212	Bearing Housing
53.	WSP156/08	2BA Cap Screw 1/2" long
54.	192X207	Inter Gear
55.	WSP121/0816T	Sq. Key Tapped 1/4" sq. x 1" long
56.	192V203	Housing

57.	192X205	Drive Shaft
58.	192X206	Drive Gear
59.	WSP258/20	Light Metric Ball Journal 20 x 47 x 14mm
60.	WSP104/27	47mm Internal Circlips
61.	192X208	Spacer
62.	192X209	Locknut
63.	WSP104/27	47mm Internal Circlips
64.	WSP258/20	Light Metric Ball Journal 20 x 47 x 14mm
65.	181DX110	Pin
66.	181DX102/45	Attached threading gear 45T
67.	WSP154/0416	1/4" B.S.F. Cap Screw 1" long
68.	WSP154/04	Spring Washer 1.4" dia.
69.	181AX130	Staggered Gears Centre
70.	WSP124/0406	1/8" dia. silver steel pin x 3/8" long
71.	192X139A	Clamp Nut
72.	WSP188/0452	1/4" B.S.F. Sq. Head Set Screw 3.1/4" long
73.	192X140	Clamp Bolt
74.	192X134	Clamp Bolt
75.	192X135A	Adjusting Gear
76.		Chaser as required
77.	192X138A	Clamp Bush
78.	WSP173/07H	7/16" B.S.F. Hex. Nut Hard
79.	WSP124/0414	1/8" dia. Silver Steel Pin 7/8" long
80.	WSP176/0406	1/4" B.S.F. Hex. Socket Set Screw Cup
81.		Point 3/8" long
82.	192X213A	Chaser Bracket
83.	192X136A	Adjusting Worm
84.	192X218	Clamp
85.	WSP154/04	1/4" dia. Spring Washer
86.	WSP155/0410	1/4" B.S.F. Socket Head Cap Screw 5/8" long
87.	WSP155/0540	5/16" B.S.F. Socket Head Cap Screw 2.1/2" long
88.	WSP154/05	5/16" dia. Spring Lock Washer
89.	WSP155/0520	5/16" B.S.F. Socket Head Cap Screw 1.1/4" long
90.	WSP154/03	3/16" dia. Spring Lock Washer
91.	WSP156/236	2BA Socket Head cap Screw 2.1/4" long

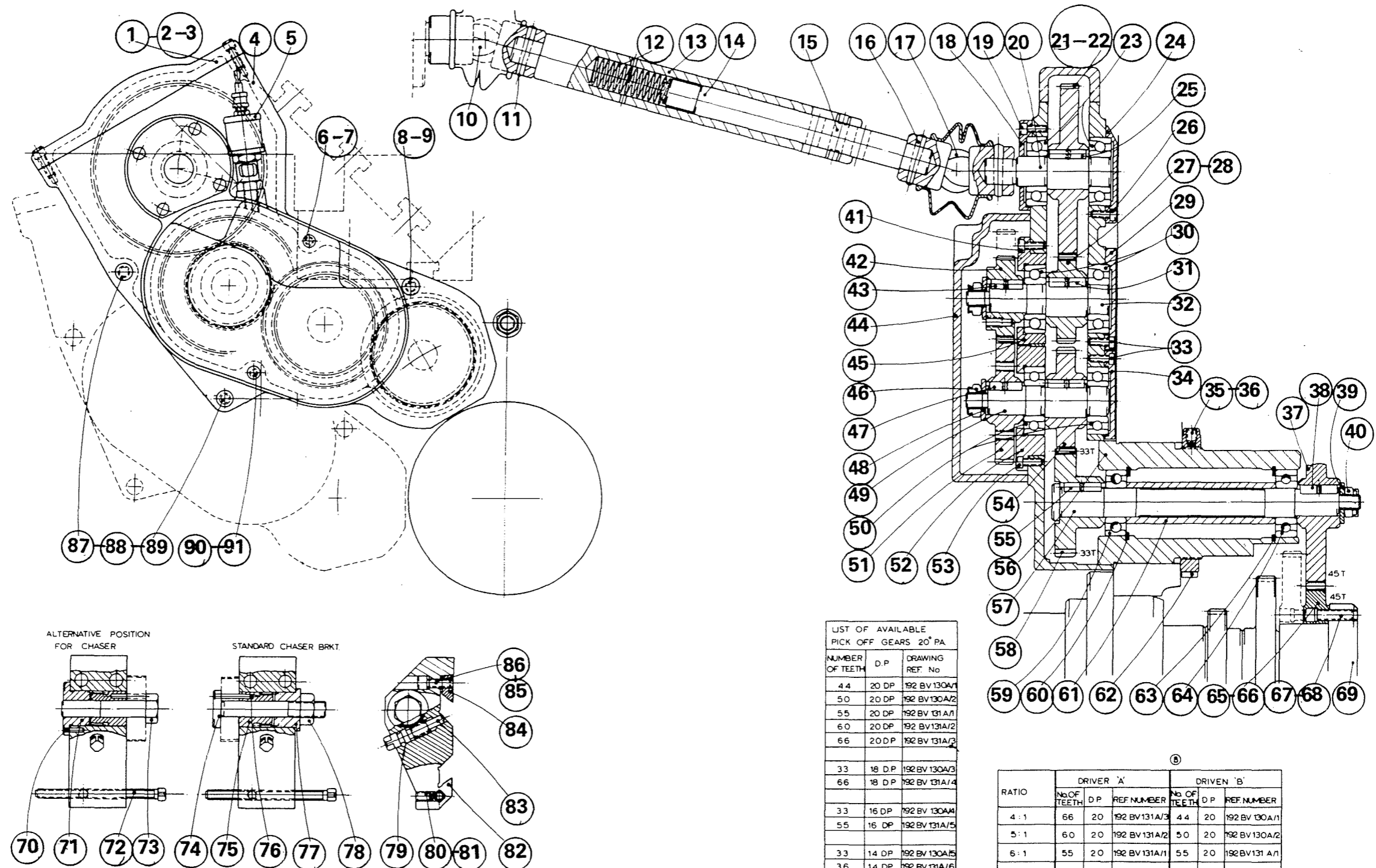

LIST OF AVAILABLE PICK OFF GEARS 20° PA

NUMBER OF TEETH	D.P.	DRAWING REF. No
4.4	20 DP	192 BV 130A/1
5.0	20 DP	192 BV 130A/2
5.5	20 DP	192 BV 131A/1
6.0	20 DP	192 BV 131A/2
6.6	20 DP	192 BV 131A/3
3.3	18 D.P.	192 BV 130A/3
6.6	18 D.P.	192 BV 131A/4
3.3	16 DP	192 BV 130A/4
5.5	16 DP	192 BV 131A/5
3.3	14 DP	192 BV 130A/5
3.6	14 DP	192 BV 131A/6
4.4	14 DP	192 BV 131A/7
4.2	14 DP	192 BV 131A/8
2.4	12 DP	192 BV 130A/6
4.4	12 DP	192 BV 131A/9

⑤

RATIO	DRIVER 'A'			DRIVEN 'B'		
	No OF TEETH	D.P.	REF NUMBER	No OF TEETH	D.P.	REF NUMBER
4:1	66	20	192 BV 131A/3	4.4	20	192 BV 130A/1
5:1	6.0	20	192 BV 131A/2	5.0	20	192 BV 130A/2
6:1	5.5	2.0	192 BV 131A/1	5.5	2.0	192 BV 131A/1
7:1	3.6	1.4	192 BV 131A/6	4.2	1.4	192 BV 131A/8
8:1	3.3	1.4	192 BV 130A/5	4.4	1.4	192 BV 131A/7
9:1	4.4	2.0	192 BV 130A/1	6.6	2.0	192 BV 131A/3
10:1	3.3	1.6	192 BV 130A/4	5.5	1.6	192 BV 131A/5
11:1	2.4	1.2	192 BV 130A/6	4.4	1.2	192 BV 131A/9
12:1	3.3	1.8	192 BV 130A/3	6.6	1.8	192 BV 131A/4
4 1/2:1	4.4	1.4	192 BV 131A/7	3.3	1.4	192 BV 130A/5

CHASING ATTACHMENT DRIVE (STATION 4) SECTION 192D

192 Z 4

Drg No.193Z1 ----- Auxiliary Cross Slide Motion - Stn.3. Sec.193

1. 150X130 Cam Roller
2. 150X129 Cam Roller Pin
3. 167/0518 5/16" B.S.F. Hex. Head Set Screw 1.1/8" long
4. 193X102 Link
5. 155/0516 5/16" B.S.F. Socket Head Cap Screw 1" long
6. 236/101207 Oil Retaining Bush
7. 137CX108 Pin
8. 193Y101A Cam Lever
9. 155/0544 5/16" B.S.F. Socket Head Cap Screw 2.3/4" long
10. 154/05 5/16" Spring Washer
11. 155/0520 5/16" B.S.F. Socket Head Cap Screw 1.1/4" long
12. 154/05 5/16" Spring Washer
13. 125/1624 1/4" Dia. Taper Pin 1.1/2" long.

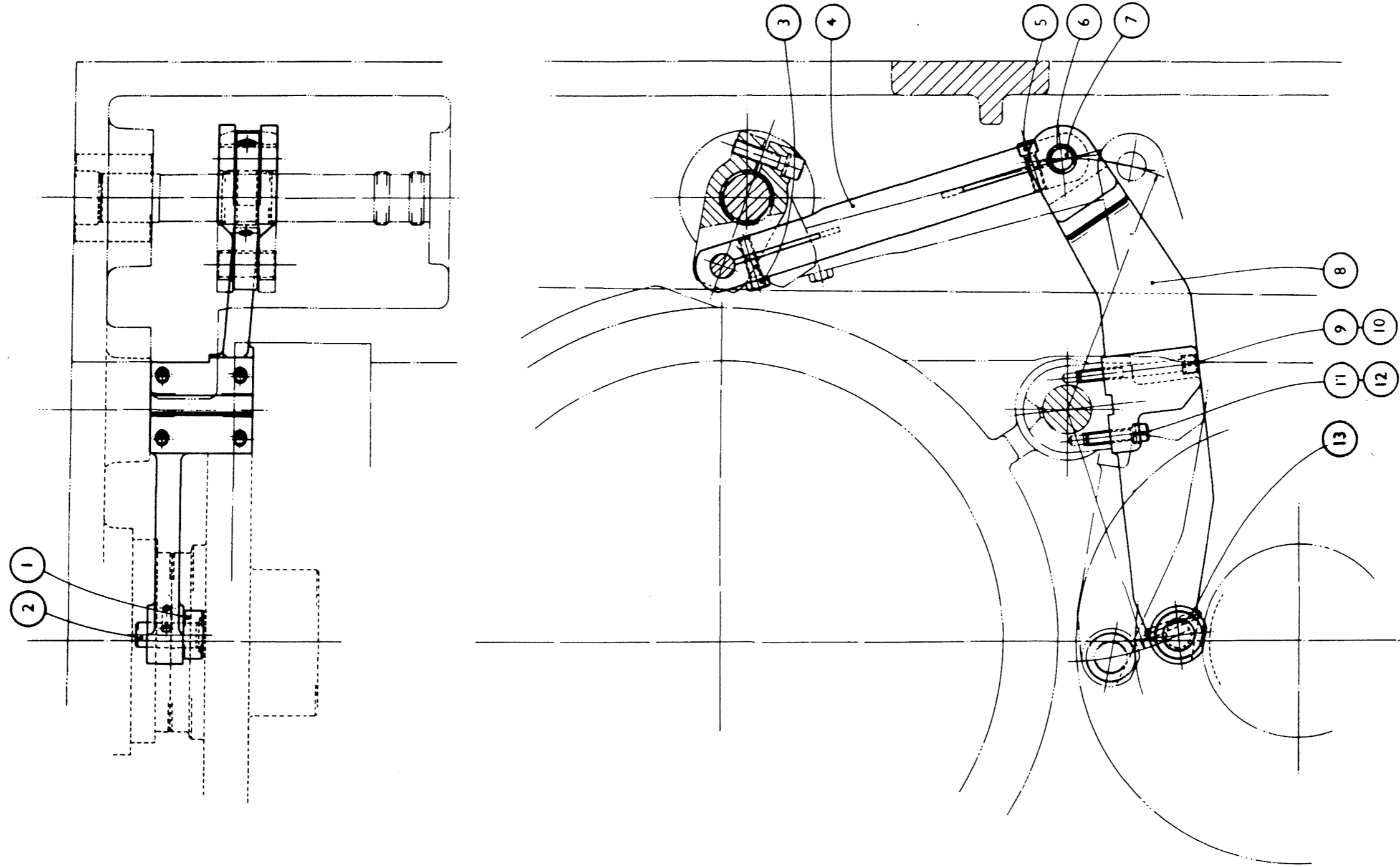

AUXILIARY CROSS SLIDE MOTION - STATION 3 SECTION 193

193 Z1

Drg No.193AZ1 ----- Auxiliary Cross Slide Motion - Station 3 -----

1. 150X129 Cam Roller Pin
2. 150X130 Cam Roller
3. 5/0520 5/16" B.S.F. Socket Head Cap Screw 1.1/4" long
4. 193AY102 Link (Aux. Motion - Upper 4th & 5th Stations).
5. 155/0520 5/16" B.S.F. Socket Head Cap Screw 1.1/4" long
6. 236/121608 Oil Retaining Bush
7. 135X128A Pivot Pin
8. 193AY101A Cam Lever (Aux. Motion 4th Station).
9. 155/0544 5/16" B.S.F. Socket Head Cap Screw 2.3/4" long
10. 155/0544 5/16" B.S.F. Socket Head Cap Screw 2.3/4" long
11. 125/1624 1/4" Dia. Taper Pin 1.1/2" long

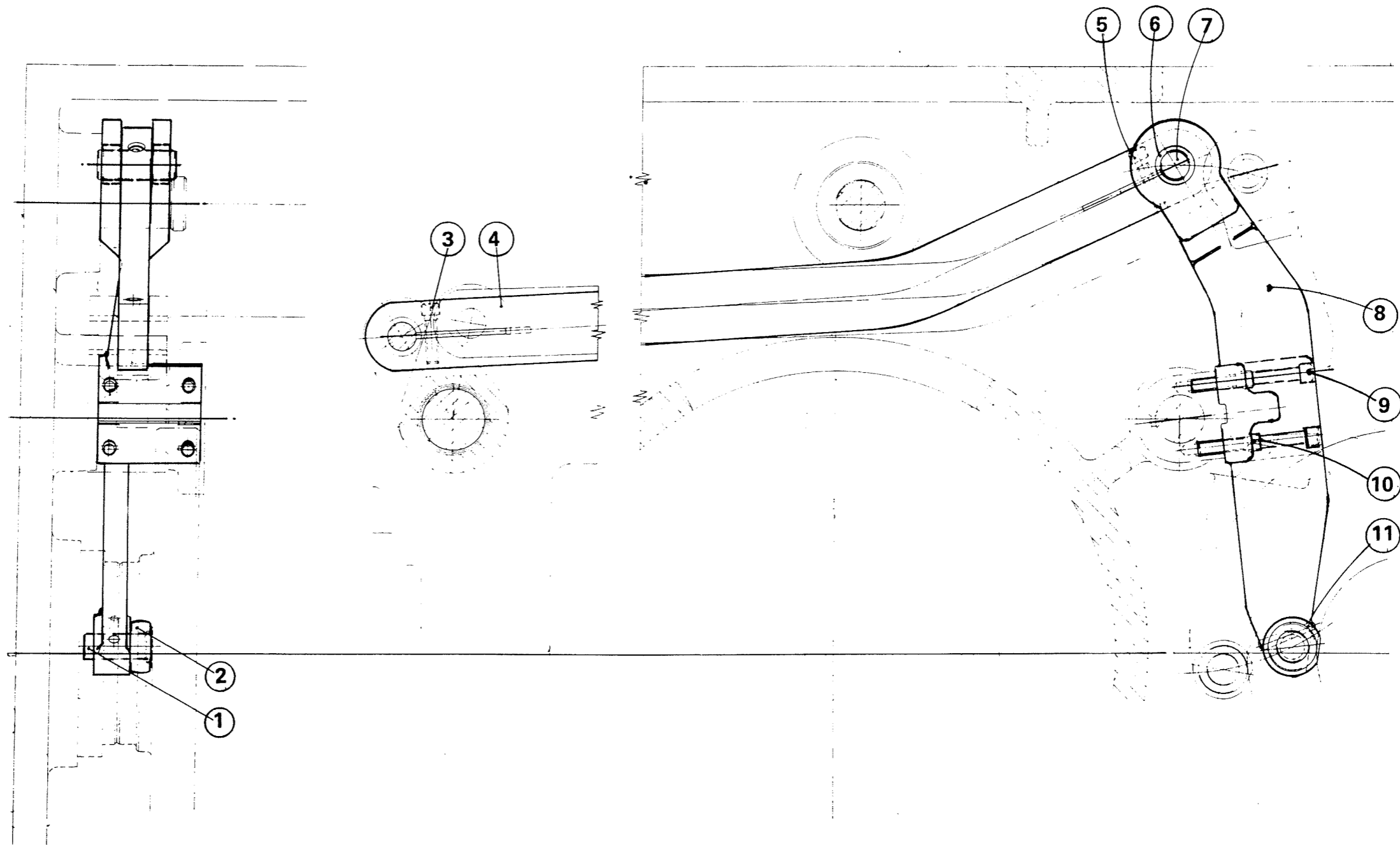

AUXILIARY CROSS SLIDE MOTION - STATION 4

193 AZ1

Drg No.193BZ1 ----- Auxiliary Cross Slide Motion - Stn.5. Sec.193B

- 1. 150X130 Cam Roller
- 2. 150X129 Cam Roller Pin
- 3. 125/1624 1/4" Dia. Taper Pin 1.1/2" long
- 4. 155/0520 5/16" B.S.F. Socket Head Cap Screw 1.1/4" long
- 5. 155/0544 5/16" B.S.F. Socket Head Cap Screw 2.3/4" long
- 6. 193BY101A Cam Lever
- 7. 135X128A Pivot Pin
- 8. 236/121608 Oil Retaining Bush
- 9. 155/0520 5/16" B.S.F. Socket Head Cap Screw 1.1/4" long
- 10. 193AY102 Link
- 11. 155/0520 5/16" B.S.F. Socket Head Cap Screw 1.1/4" long

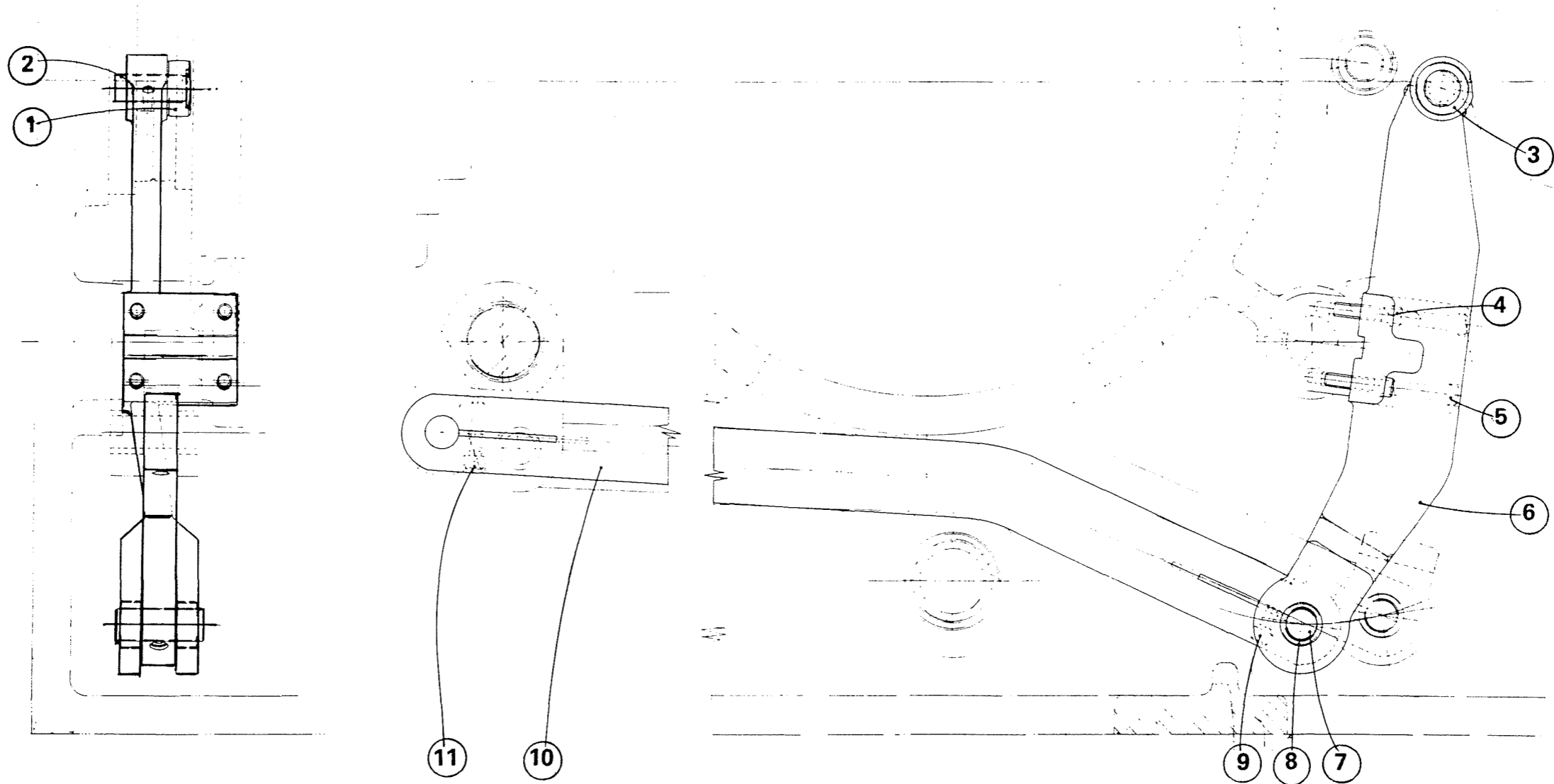

AUXILIARY CROSS SLIDE MOTION - STATION 5 SECTION 193B

193 BZ1

Drg No.193CZ1 ----- Auxiliary Cross Slide Motion - Stn.6. Sec.193C -----

1. 150X130 Cam Roller
2. 150X129 Cam Roller Pin
3. 125/1624 1/4" Dia. Taper Pin 1.1/2" long
4. 155/0520 5/16" B.S.F. Socket Head Cap Screw 1.1/4" long
5. 155/0544 5/16" B.S.F. Socket Head Cap Screw 2.3/4" long
6. 193CY101A Cam Lever (Aux. Motion 6th Station)
7. 137CX108 Pin
8. 236/101207 Oil Retaining Bush
9. 155/0516 5/16" B.S.F. Socket Head Cap Screw 1" long
10. 193X102 Link (Aux. Motion 3rd and 6th Stations).
11. 167/0518 5/16" B.S.F. Hexagon Head Set Screw 1.1/8" long

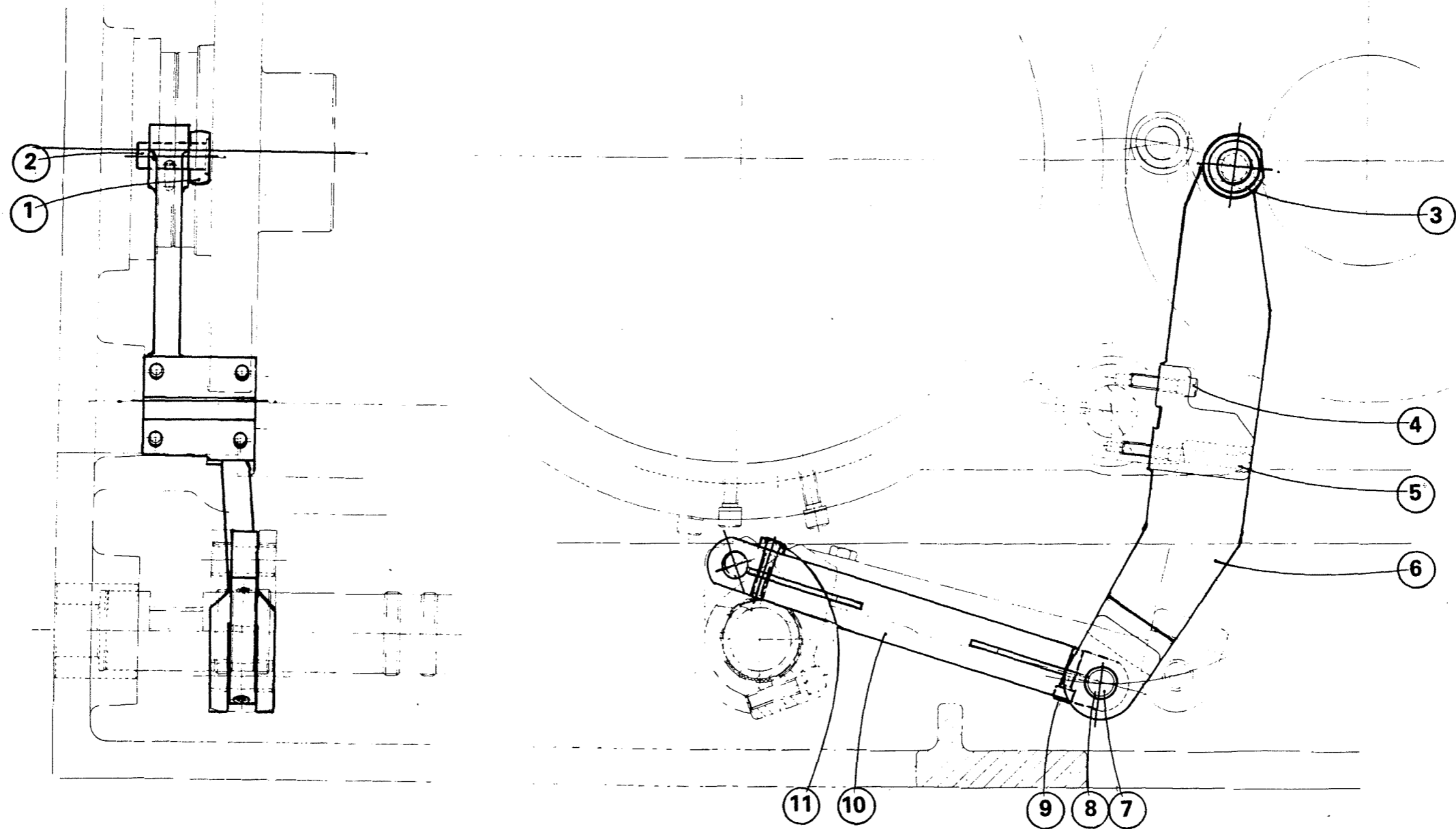

AUXILIARY CROSS SLIDE MOTION - STATION 6 SECTION 193C

Drq No.195Z1A ----- Pick-Up Attachment (6th Station). Sec.195

1.	195X108A	Collet Retainer
2.	195X110	Coolant Gland
3.	195X111A	End Plate
4.	195X112	Ring Housing
5.	SB77	Extra Light Double Purpose Journal
6.	195X120	Spacer
7.	WSP268/40	Extra Light Rigid Ball Journal
8.	195X121	Spacer
9.	195X119	Locating Sleeve
10.	WSP354/0S7	'O' Ring .375 Shaft dia. .500 recess
11.	195X134	Compensating Washer
12.	WSP150/20	1.1/4" Slotted Locknut
13.	195X136	Coupling Nut
14.	195X116	Ejector Rod (Short)
15.	195Y103	Slide
16.	WSP155/0510	5/16" B.S.F. Socket Head Cap Screw x 1/2"
17.	C18547	Collet to suit component
18.	195X109	Drive Pin
19.	195V104	Collet Sleeve
20.	195X113A	Piston Ring
21.	D53581	Ejector to suit component
22.	195X115	Ejector Plunger
23.	WSP125/0810	1/8" dia. Taper Pin 5/8" long
24.	WSP235/M5068	Oil Seal 50 x 68 x 10mm
25.	WSP151/40	40mm Slotted Locknut
26.	195X137	Slotted Locknut
27.	195X132	Toggle
28.	195X135	Pressure Disc
29.	195Y102A	Work Spindle
30.	195V107	Splined Drive Shaft
31.	195X118	Ejector Pin
32.	WSP155/0424	1/4" B.S.F. Socket Head Cap Screw 1.1/2" long
33.	WSP173/05H	5/16" B.S.F. Hexagon Nut
34.	WSP167/0532H	5/16" B.S.F. Hexagon Head Set Screw x 2" long
35.	WSP212/18	Grease Nipple
36.	WSP210/2525	Indicator Washer
37.	WSP145/200	Morris Spring (Compression)
38.	195Z101A	Attachment Body
39.	WSP176/0405	1/4" B.S.F. Socket Set Screw x 5/16" long
40.	WSP153/04	Soft Pad for 1/4" B.S.F. Hole
41.	WSP176/0405	1/4" B.S.F. Socket Set Screw x 5/16" long
42.	WSP153/04	Soft Pad for 1/4" B.S.F. Hole
43.	WSP176/0405	1/4" B.S.F. Socket Set Screw x 5/16" long
44.	WSP153/04	Soft Pad for 1/4" B.S.F. Hole
45.	WSP176/0404	1/4" B.S.F. Socket Set Screw x 1/4" long
46.	WSP153/04	Soft Pad for 1/4" B.S.F. Hole
47.	195X126	Guide Bar (Lower)
48.	WSP355/75	Retaining Ring, External 3/4" dia.
49.	WSP155/0408	1/4" B.S.F. Socket Head Cap Screw x 1/2" long
50.	195X139	Guide Strip
51.	WSP193/106	1/8" BSP Socket Pipe Plug 3/8"
52.	WSP154/05	5/16" B.S.F. Lockwasher
53.	WSP155/0516	5/16" B.S.F. Hexagon Socket Head Cap Screw 1" long
54.	195X146	Stock Bracket
55.	169X145/20	Hose Assembly

56.	WSP173/05	5/16" B.S.F. Hexagon Locknut
57.	195X122	Trip Rod
58.	WSP219/17	Male Elbow Adaptor
59.	WSP174/2L	Hexagon Locknut 2BA
60.	WSP181/212	Socket Set Screw, half dog, 2BA x 3/4" long
61.	195X140	Gib Strip
62.	WSP155/0510	5/16" B.S.F. Socket Head Cap Screw 5/8" long
63.	188X111	T-Nut
64.	WSP326/0410	1/8" dia. Tension Pin, 5/8" long
65.	195X140	Gib Strip
66.	195X205	Wear Strip
67.	162/604	Countersunk Screw, 6BA, 1/4" long
68.	195X117	Ejector Rod (Long)
69.	188X108	Trip Clamp
70.	WSP195/0512	Collar Head Screw 5/16" B.S.F. x 1" long
71.	WSP203/04	Self Locking Hex. Nut 1/4" BSF
72.	WSP155/0432	1/4" B.S.F. Socket Head Cap Screw x 2" long
73.	195X138	Ejector Bung
74.	WSP173/08	1/2" B.S.F. Hexagon Nut
75.	195X124	Washer
76.	WSP326/0612	3/16" dia. Tension Pin 3/4" long
77.	195X125	Guide Bar (Upper)
78.	195V106	Glut
79.	WSP159/406	4BA Hexagon Socket Countersunk screw 3/8" long
80.	195X129	Plunger
81.	195X130	Bush
82.	195X149	Cover Plate
83.	WSP145/138	Morris Spring (Compression)
84.	195X123	Sleeve
85.	WSP155/0512	5/16" B.S.F. Hexagon Socket Head Cap Screw 3/4" long
86.	195X147	Stop Bush
87.	188X108	Trim Clamp
88.	WSP195/0512	5/16" B.S.F. Hexagon Socket Head Cap Screw 3/4" long
89.	WSP121/0832	1/4" Square Key 2" long
90.	WSP179/204	2BA Socket Set Screw 1/4" long
91.	WSP153/42	Soft Pad for 2BA Hole
92.	WSP150/14	7/8" Slotted Locknut
93.	FX7769	Pin for Toggles
94.	WSP121/0824	1/4" Square Key 1.1/2" long
95.	195X131	Toggle Sleeve
96.	195V105	Clutch Bobbin
97.	195X133	Key
98.	WSP156/406	4BA Socket Head Cap Screw x 3/8" long
99.	WSP156/404	4BA Socket Head Cap Screw x 1/4" long
100.	WSP198/4	Lockwasher for 4BA
101.	WSP225/3035	3/16" O/Dia. Copper Tube
102.	WSP215/3	Enots Tubing Nuts, 3/16" Tube
103.	WSP221/3	Enots Tubing Sleeve
104.	WSP155/0408	1/4" B.S.F. Socket Head Cap Screw x 1/2" long
105.	195X148	Oil Feed Bracket
106.	WSP222/1	Enots Bulkhead Connector
107.		Locknut
108.	195X141/8	Lubricating Hose Assembly

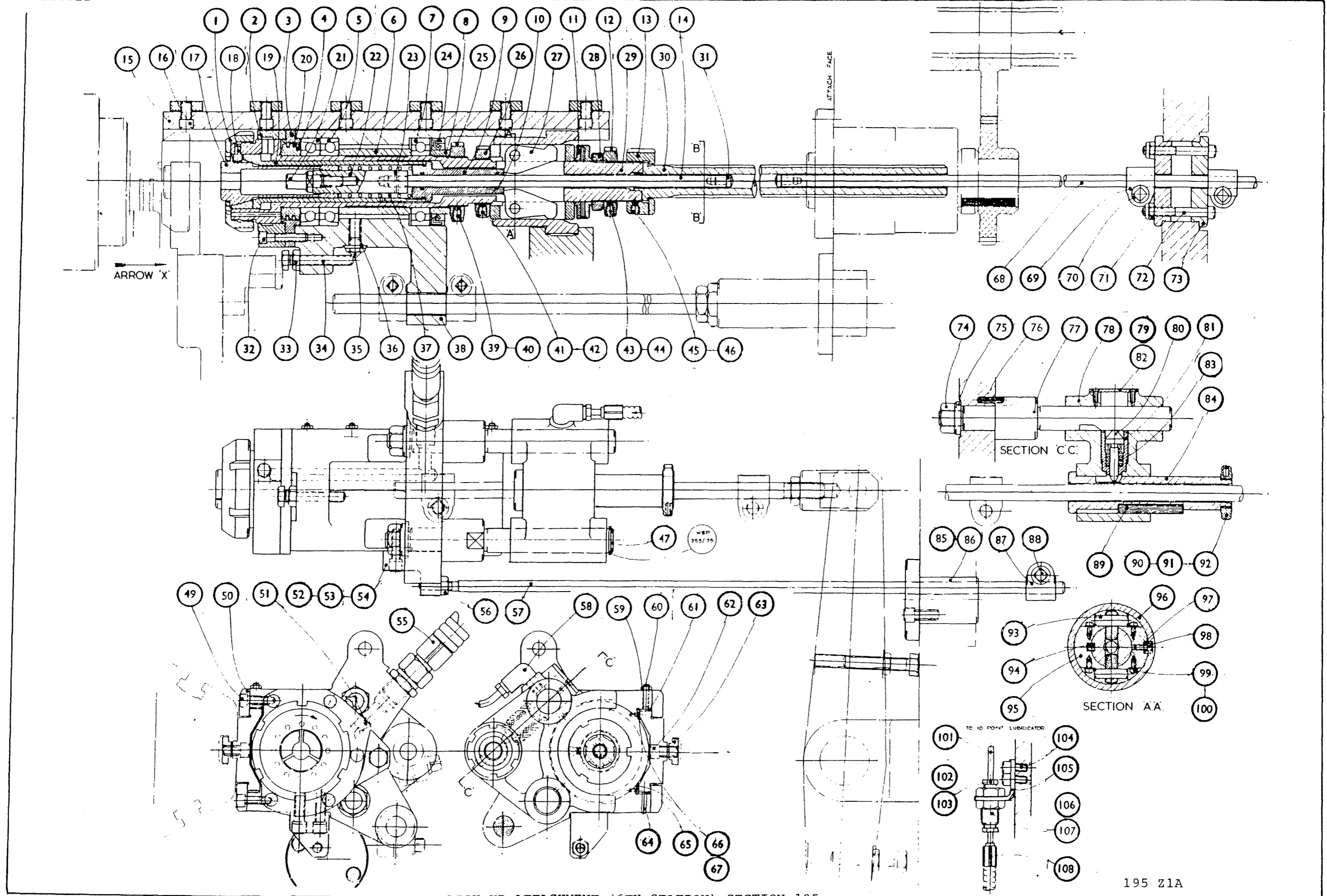

PICK-UP ATTACHMENT (6TH STATION) SECTION 195

195 Z1A

Drg No.195Z2A ----- Pick-Up Attachment (3rd Station). Sec.195A

1. WSP155/0432 1/4" B.S.F. Socket Head Cap Screw x 2" long
2. 195X138A Ejector Bung
3. WSP203/04 Self Locking Hexagon Nut 1/4" B.S.F.
4. WSP195/0512 5/16" B.S.F. Collar Head Screw x 3/4" long
5. 188X108 Trip Clamp
6. 195X117 Ejector Rod (Long)
7. 195X118 Ejector Pin
8. 195X116 Ejector Rod (Short)
9. 195V107 Drive Shaft, Splined
10. WSP153/04 Soft Pad for 1/4" B.S.F. Hole
11. WSP176/0405 1/4" BSF Socket Set Screw x 5/16" long
12. WSP150/20 1/1/4" Slotted Locknut
13. 188X111 T-Nut
14. WSP155/0508 5/16" B.S.F. Socket Head Cap Screw 1/2" long
15. 195Y103 Slide
16. 195X131 Toggle Sleeve
17. 195X132 Toggle
18. 195V105 Clutch Bobbin
19. WSP153/04 Soft Pad for 1/4" B.S.F. hole
20. WSP176/0405 1/4" B.S.F. Socket Set Screw x 5/16" long
21. 195X137 Slotted Locknut
22. WSP153/04 Soft Pad for 1/4" B.S.F. hole
23. WSP176/0405 1/4" B.S.F. Socket Set Screw x 5/16" long
24. WSP151/40 40mm Slotted Locknut
25. WSP268/40 Extra Light Rigid Ball Journa;
26. 195X120 Spacer
27. WSP125/0810 1/8" dia. Taper Pin, 5/8" long
28. WSP145/200 Morris Spring (Compression#
29. 195X115 Ejector Plunger
30. SB77 Extra Light Double Purpose Journal
31. D53581 Ejector to suit component
32. 195AX144 End Plate
33. 195X113A Piston Ring
34. 195X112 Ring Housing
35. 195Y102A Work Spindle
36. 195X109 Drive Pin
37. WSP153/04 Soft Pad for 1/4" B.S.F. Hole
38. WSP176/0404 1/4" B.S.F. Socket Set Screw x 1.4" long
39. 195X136 Coupling Nut
40. 195X135 Pressure Disc
41. 195X134 Compensating Washer
42. WSP354/0S7 'O' Ring .375 Shaft Dia. 500 recess
43. 195X119 Locating Sleeve
44. 195X121 Spacer
45. WSP235/M5068 Oil Seal 50 x 68 x 10mm
46. 195Z142 Attachment Body
47. WSP212/18 Grease Nipple
48. WSP210/2525 Indicator Washer
49. SP167/0532H 5/16" BSF Hexagon Head Set Screw x 2" long
50. WSP173/05H 5/16" B.S.F. Hexagon Nut
51. 195X143 Coolant Gland
52. WSP155/0424 1/4" B.S.F. Socket Head Cap Screw x 1.1/2" long
53. 195V104 Collet Sleeve
54. 195X108A Collet Retainer
55. C18547C Collet to suit component
56. WSP225/3035 3/16" dia. Copper Tube

57.	WSP155/0408	1/4" B.S.F. Socket Head Cap Screw x 1/2" long
58.	195X148	Oil Feed bracket
59.	WSP215/3	Enots Tubing Nut, 3/16" tube
60.	WSP221/3	Enots Tubing Sleeve, 3/16"
61.	WSP221/3	Enots Tubing Sleeve, 3/16"
62.	WSP215/3	Enots Tubing Nuts, 3/16" tube
63.	WSP222/1	Enots Bulkhead Connector
64.		Locknut
65.	915X122	Trip Rod
66.	WSP173/05	5/16" B.S.F. Hexagon Locknut
67.	195X141/18	Lubricating Hose Assembly
68.	WSP221/3	Enots Tubing Sleeve, 3/16"
69.	WSP215/3	Enots Tubing Nuts 3/16" tube
70.	WSP219/17	Male Elbow Adaptor, 3/16"
71.	WSP195/0512	5/16" B.S.F. Collar Head Screw, 3/4" long
72.	188X108	Trip Clamp
73.	WSP159/406	4BA Hexagon Socket Countersunk Screw 3/8" long
75.	195V106	Glut
76.	195X125	Guide Bar (Upper)
77.	WSP326/0612	3/16" dia. Tension Pin 3/4" long
78.	195X124	Washer
79.	WSP173/08	1/2" B.S.F. Hexagon Nut
80.	195X126	Guide Bar Lower
81.	WSP355/75	3/4" dia. Retaining Ring (External)
82.	169X145/20	Hose Assembly
83.	WSP156/406	4BA Socket Head Cap Screw x 3/8" long
84.	195X133	Key
85.	FX7769	Pin for Toggles
86.	WSP198/4	Lockwasher for 4BA
87.	WSP156/404	4BA Socket Head Cap Screw 1/4" long
88.	WSP121/0824	1/4" Square Key, 1 1/2" long
89.	195X140	Gib Strip
90.	WSP181/212	2BA Socket Set Screw, Half Dog x 3/4" long
91.	WSP174/2L	2BA Hexagon Locknut
92.	195X139	Guide Strip
93.	WSP155/0408	1/4" B.S.F. Socket Head Cap Screw x 1/2" long
94.	WSP193/106	1/8" B.S.P. Socket Pipe Plug x 3/8" long
95.	WSP150/14	7/8" Slotted Locknut
96.	WSP179/204	2BA Socket Set Screw x 1/4" long
97.	WSP153/42	Soft Pad for 2BA Hole
98.	195X123	Sleeve
99.	WSP121/0832	1/4" Square Key, 2" long
100.	195X130	Bush
101.	195X129	Plunger
102.	WSP145/138	Morris Spring (Compression)
103.	WSP326/0410	1/8" dia. Tension Pin, 5/8" long
104.	195X205	Wear Strip
105.	162/604	6BA Core Head screw x 1/4" long
106.	-	Section 'AA'
107.	-	Section 'CC'
108.	-	Section 'BB'
109.	-	View in direction of Arrow 'X'

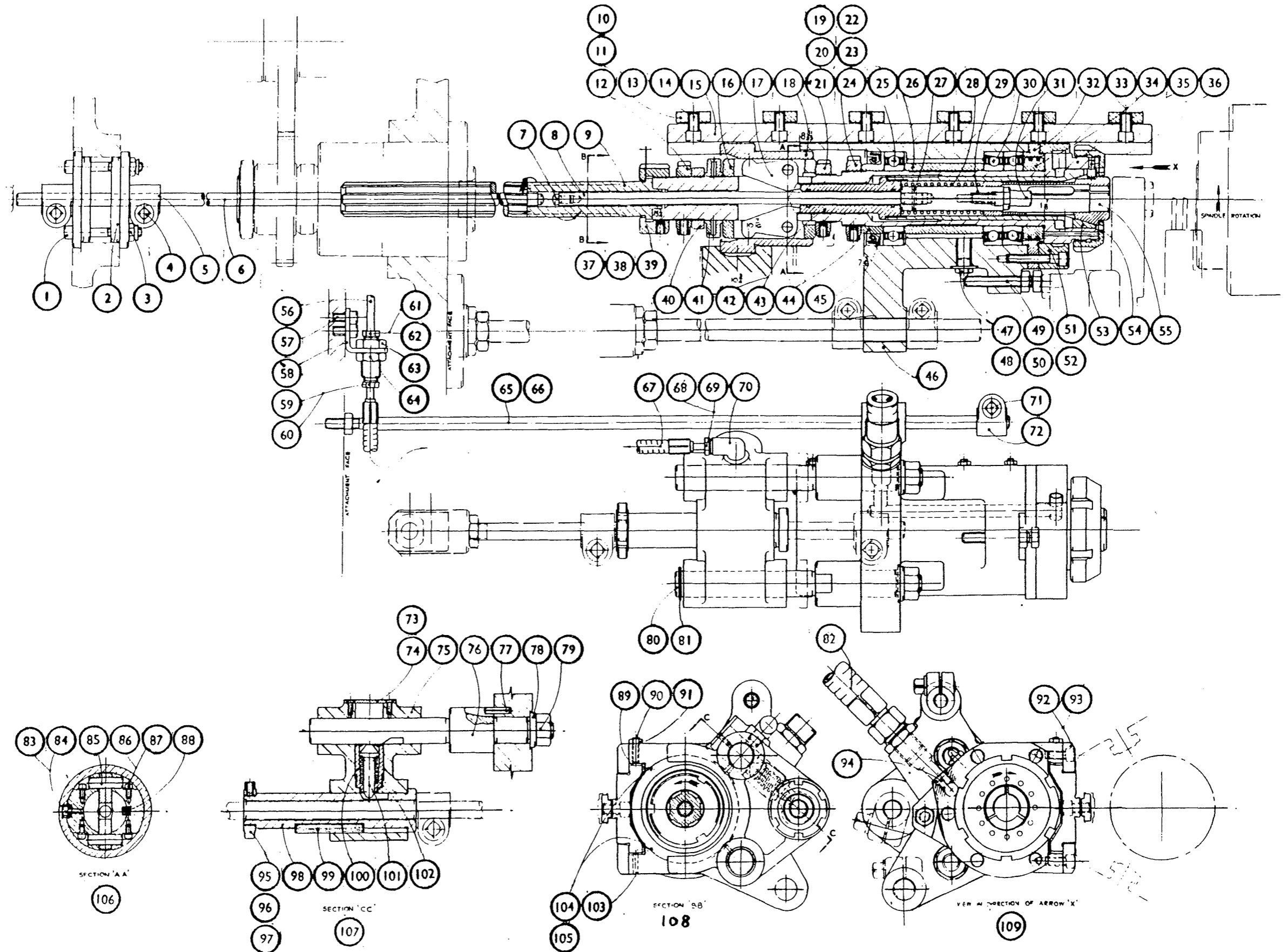

PICK-UP ATTACHMENT (3RD STATION) SECTION 195A

195 Z 2A

1. 195X167 Pivot Pin
2. WSP130/07 Washer 7/16" bore
3. WSP203/07 7/16" B.S.F. Self Locking Nut
4. 195V173 3rd Station Operating Lever
5. 195Y163 Collet Operating Lever
6. WSP203/07 7/16" B.S.F. Self Locking Nut
7. WSP130/07 Washer 7/16" bore
8. 195X167 Pivot Pin
9. 195X171 Push Rod
10. 388X105 Trip Clamp
11. WSP195/0616 3/8" B.S.F. Clamping Collar Head Screw x 1"
12. WSP173/08L 1/2" B.S.F. Hexagon Locknut
13. 195X168 Connector
14. 195Y163 Collet Operating Lever
15. WSP203/07 7/16" Self Locking Nut
16. WSP130/07 Washer 7/16" bore
17. 195X167 Pivot Pin
18. 195Y161 Support Bracket
19. WSP155/0724 7/16" B.S.F. Socket Head Cap Screw 1.1/2"
20. WSP154/07 Spring Steel Washer 7/16" bore
21. WSP355/150 External Retaining Circlip 1.1/2" shaft
22. 195Y161 Support Bracket
23. WSP155/0724 7/16" B.S.F. Socket Head Cap Screw x 1.1/2"
24. WSP154/07 Spring Steel Washer 7/16" bore
25. 195X169 Special Taper Pin
26. WSP130/05 Washer 5/16" bore
27. WSP203/05L 5/16" B.S.F. Hexagon Locknut
28. 195X170 Shaft
29. 195X172 Key
30. SP155/0652 3/8" B.S.F. Socket Head Cap Screw x 3.1/4"
31. WSP155/0410 1/4" B.S.F. Socket Head Cap Screw x 5/8"
32. 195X170 Shaft
33. WSP326/0616 3/16" Tension Pin x 1" long
34. 153X143 Roller Pin
35. 153X142 Cam Roller
36. WSP167/0632 3/8" B.S.F. Hexagon Head Set Screw x 2"
37. WSP173/06 3/8" B.S.F. Hexagon Nut
38. WSP326/0616 3/16" Tension Pin x 1" long
39. 153X143 Roller Pin
40. 153X142 Cam Roller
41. 195X172 Key
42. WSP155/0410 1/4 B.S.F. Socket Head Cap Screw x 5/8"
43. WSP155/0652 3/8" B.S.F. Socket Head Cap Screw x 3.1/4"
44. WSP155/0410 1/4 B.S.F. Socket Head Cap Screw x 5/8"
45. 195Y164 Cover
46. WSP130/05 Washer 5/16" bore
47. WSP173/05H Hexagon Nut Hard 5/16" B.S.F.
48. 195X166 Tee Bolt
49. 195X165 Cam Dog
50. 195Y162 Cam Drum

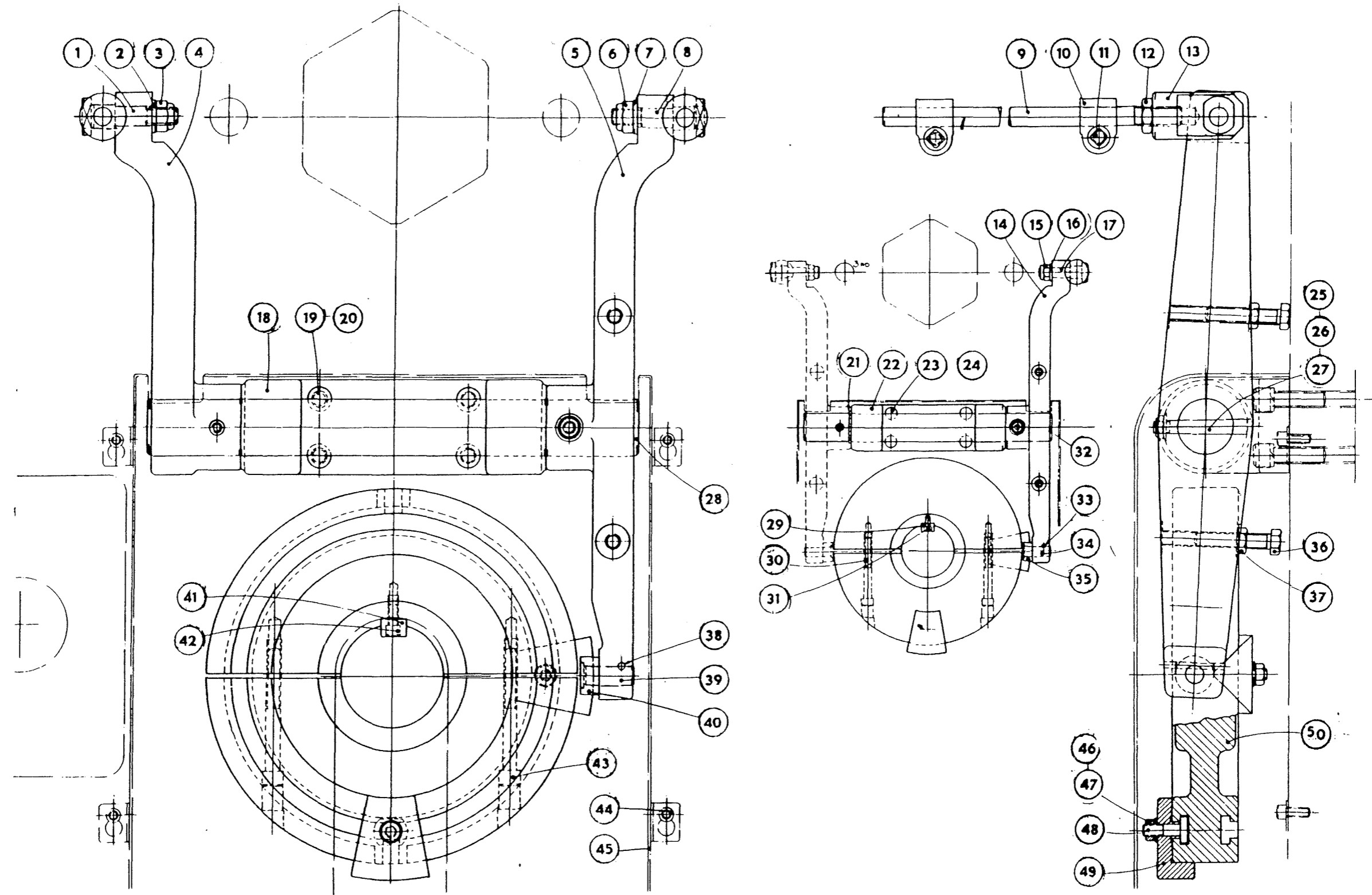

PICK-UP ATTACHMENT (COLLET OPERATION 3RD - 6TH STATION)

195 Z3

Drg No.195Z5 Bar Stop Mechanism for Back Burr. Stn.6. Sec.195E

1. 195V191 Bar Stop Bracket
2. 195V193 Stop Bracket
3. WSP155/0836 1/2 B.S.F. Socket Head Cap Screw x 2.1/4" long
4. 150X111 Pad Bush
5. WSP130/06 3/8" I/Dia. Plain Washer
6. WSP169/0604 3/8" B.S.F. Hexagon Bolt High Tensile x 2.1/2" long
7. 195X204 Eccentric Pin
8. WSP326/0616 3/16" dia. Tension Pin x 1"
9. 195X198 Bar Stop
10. 195X194 Bar Stop
11. WSP176/0506 5/16" B.S.F. Socket Set Screw Cup Point x 3/82 long
12. 150X107 Key
13. WSP156/206 2BA Socket Head Cap Screw x 3/8" long
14. 150X110 Pad Bush
15. WSP122/L224 Key
16. WSP173/06H 3/8" B.S.F. Hexagon Nut Hard
17. WSP188/0648 3/8" B.S.F. Square Head Set Screw x 3"
18. 195X192 Stop Bracket
19. 195X195 Dead Stop
20. WSP155/0508 5/16" B.S.F. Socket Head Cap Screw x 1/2" long
21. 195Z200 Cam
22. WSP155/0620 3/8" B.S.F. Socket Head Cap Screw x 1.1/4" long
23. WSP154/06 Spring Steel Washer

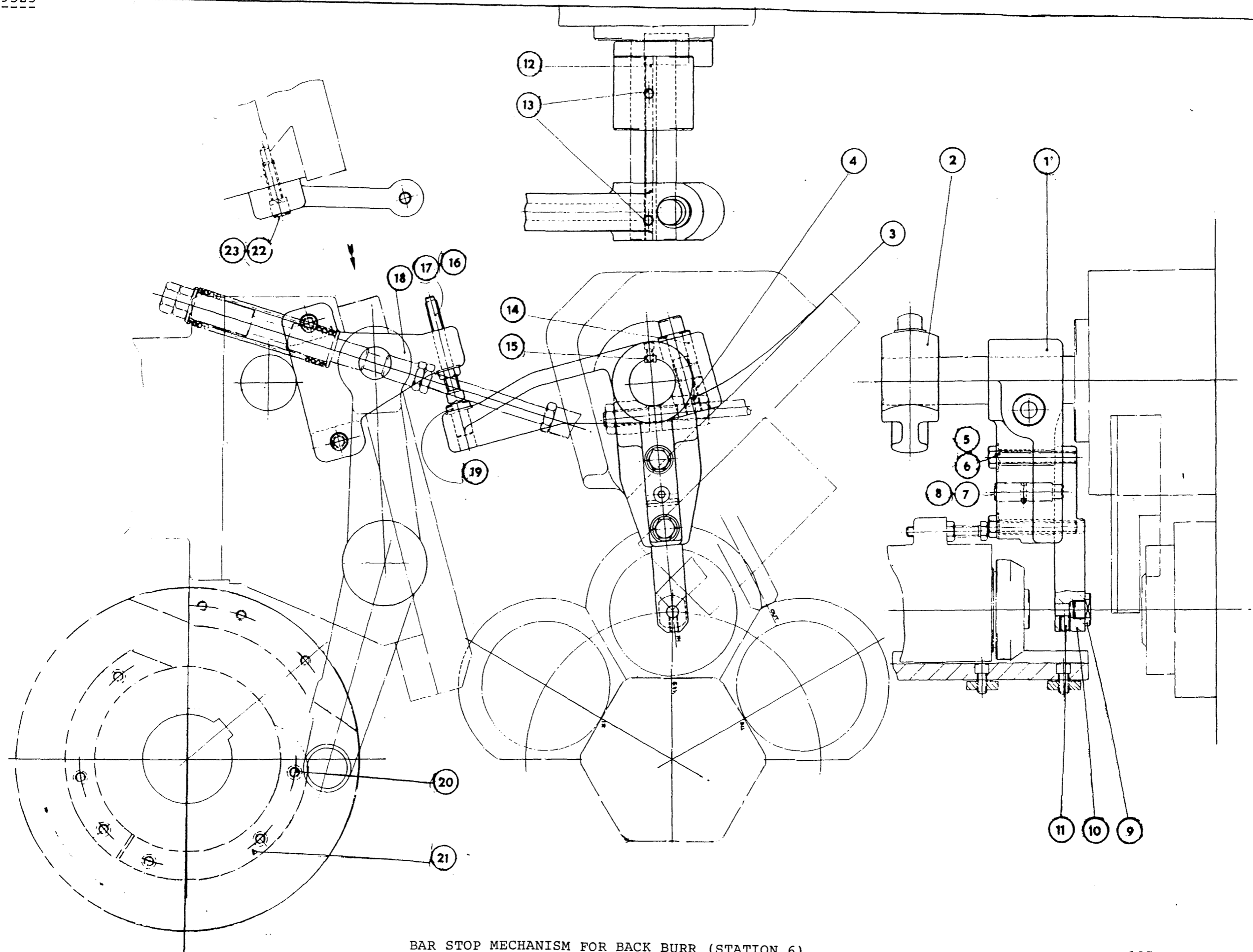

BAR STOP MECHANISM FOR BACK BURR (STATION 6)

195 Z 5

Drg No.195Z6 Bar Stop Mechanism for Back Burr. Stn.3. Sec.195E

1. 195X198 Bar Stop
2. 195X194 Bar Stop
3. WSP176/0506 5/16" B.S.F. Grub Screw x 3/8"
4. 195V191 Bar Stop Bracket
5. 195V193 Stop Bracket
6. WSP155/0836 1/2 B.S.F. Socket Head Cap Screw x 2.1/4" long
7. 150X111 Pad Bush
8. 150X110 Pad Bush
9. WSP122/1224 Key
10. 195X195 Dead Stop
11. WSP156/206 2BA Socket Head Cap Screw x 3/8" long
12. 150X107 Key
13. 195Z203 Cam
14. 195Z203 Cam
15. WSP155/0508 5/16" B.S.F. Socket Head Cap Screw x 1/2"
16. WSP173/06H 3/8" B.S.F. Hexagon Nut Hard
17. WSP188/0648 3/8" B.S.F. Square Head Set Screw x 3"
18. 195X192 Stop Bracket
19. WSP155/0620 3/8" B.S.F. Socket Head Cap Screw 1.1/4" long
20. WSP154/06 Spring Steel Washer

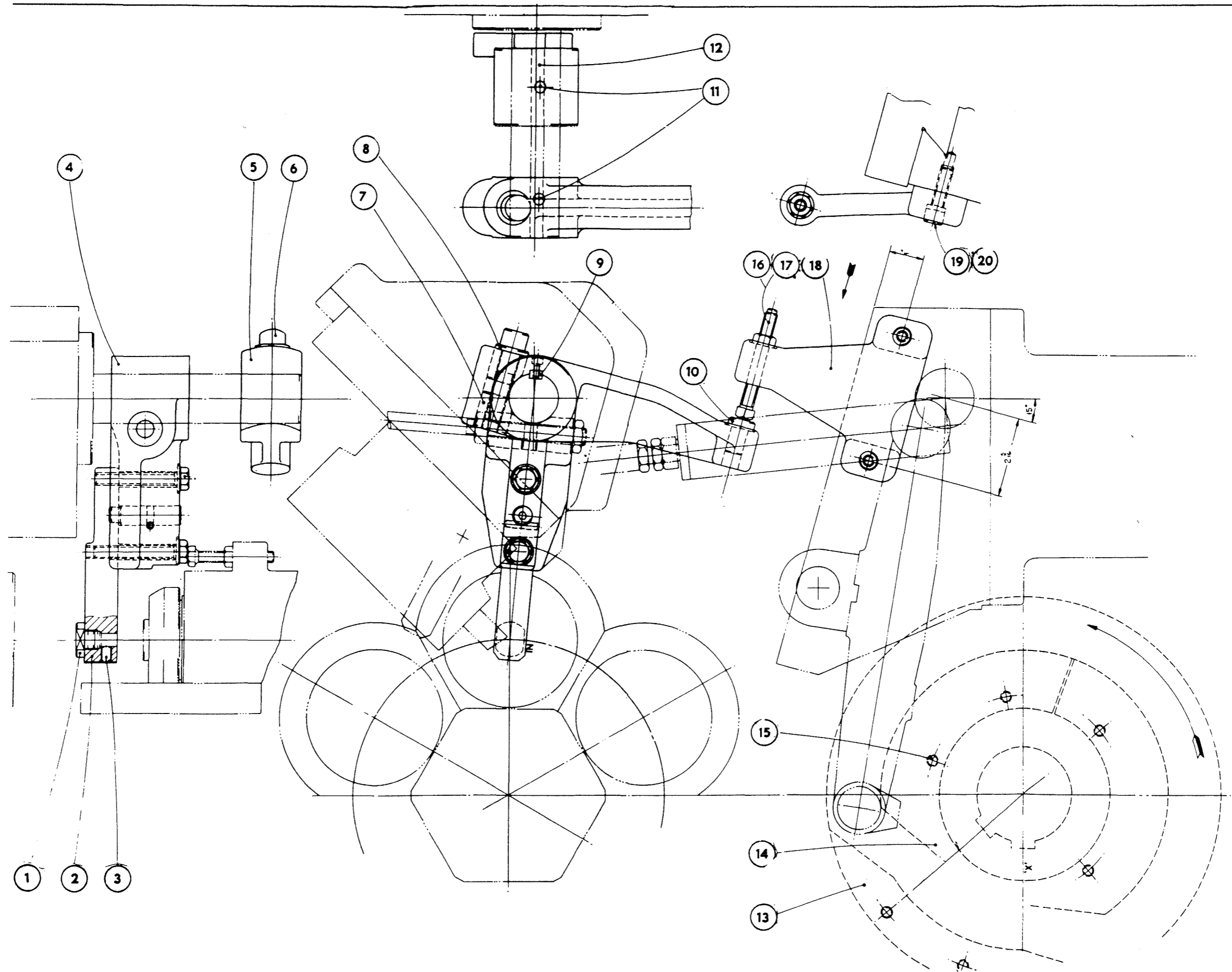

BAR STOP MECHANISM FOR BACK BURR (STATION 3) SECTION 195E

195 Z 6