



TAJMAC – FRANCE

PIÈCES DETACHÉES

GILDEMEISTER

AS/GS/GM20

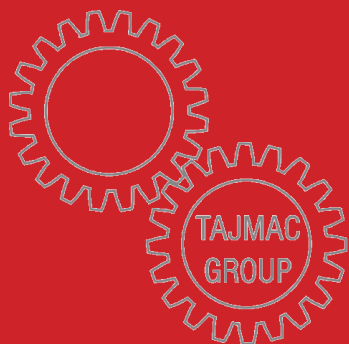

SOMMAIRE

Cames	3
Pick-up hydraulique / Coulisse	4-8
Commande de bloc central	9
Système Serrage / Avance	10-15
Bras de reprise	16
Axes / Galets	17
Boîte de vitesse	18-20
Leviers de coulisses	21-22
Commandes axiales	23-25
Croix de malte	26-27
Arbres à cames	28
Broches de poussée / Lunettes	29-31
Broches principales	32-33
Anneau de ravitaillement	34-35
Butée de barre	36
Appareillages, pinces	37-39

Cames



CAMES STANDARD POUR COULISSES TRANSVRSALES

CAMES STANDARD POUR LES BROCHES

CAMES STANDARD POUR COULISSES AXIALES

POS. 1	POS. 2-3-4-5-6	POS. 1	POS. 2-3-4-5-6	POS. 1	POS. 2-3-4-5-6
08.29.105	08.29.101	16.29.401	08.29.201	16.29.201	08.29.601
08.29.106	08.29.102	16.29.402	08.29.202	16.29.202	08.29.602
08.29.107	08.29.103	16.29.403	08.29.203	16.29.203	08.29.603
08.29.111	08.29.104	16.29.404	08.29.204	16.29.204	08.29.604
08.29.117	08.29.118	16.29.405	08.29.205	16.29.205	08.29.605
16.29.301		16.29.406	16.29.408	16.29.206	08.29.606
		16.29.407		16.29.207	08.29.607

Pick-up hydraulique ou pneumatique pos.6 et pos.3

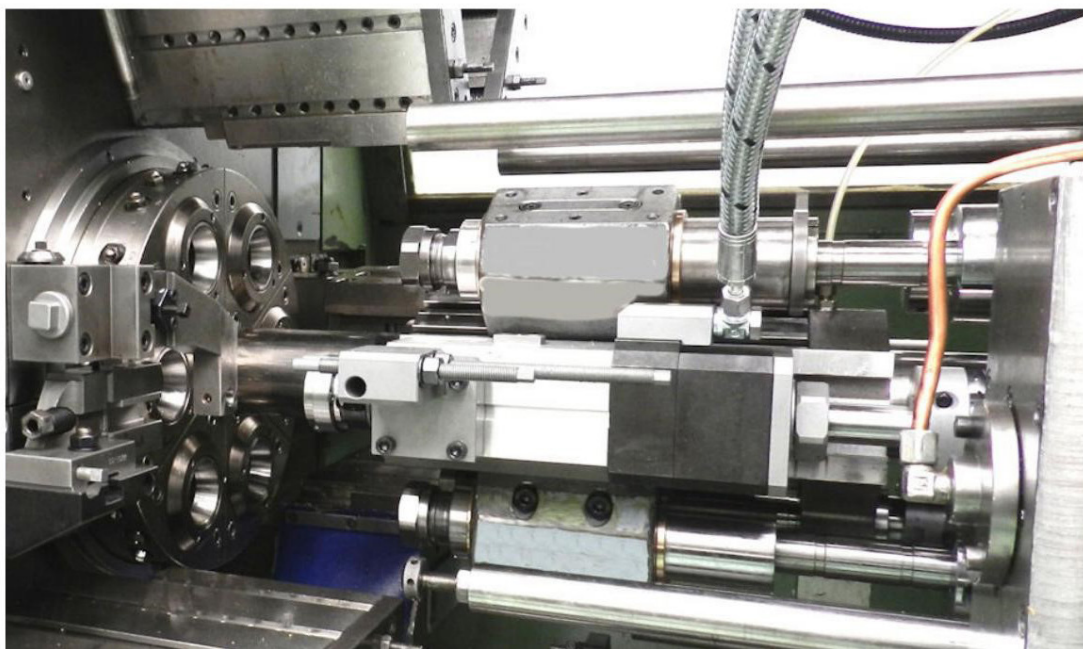

Nous pouvons fournir de nouveaux accessoires complets ou des pièces de rechange pour vos pièces détachées originaux.

Pick-up hydraulique

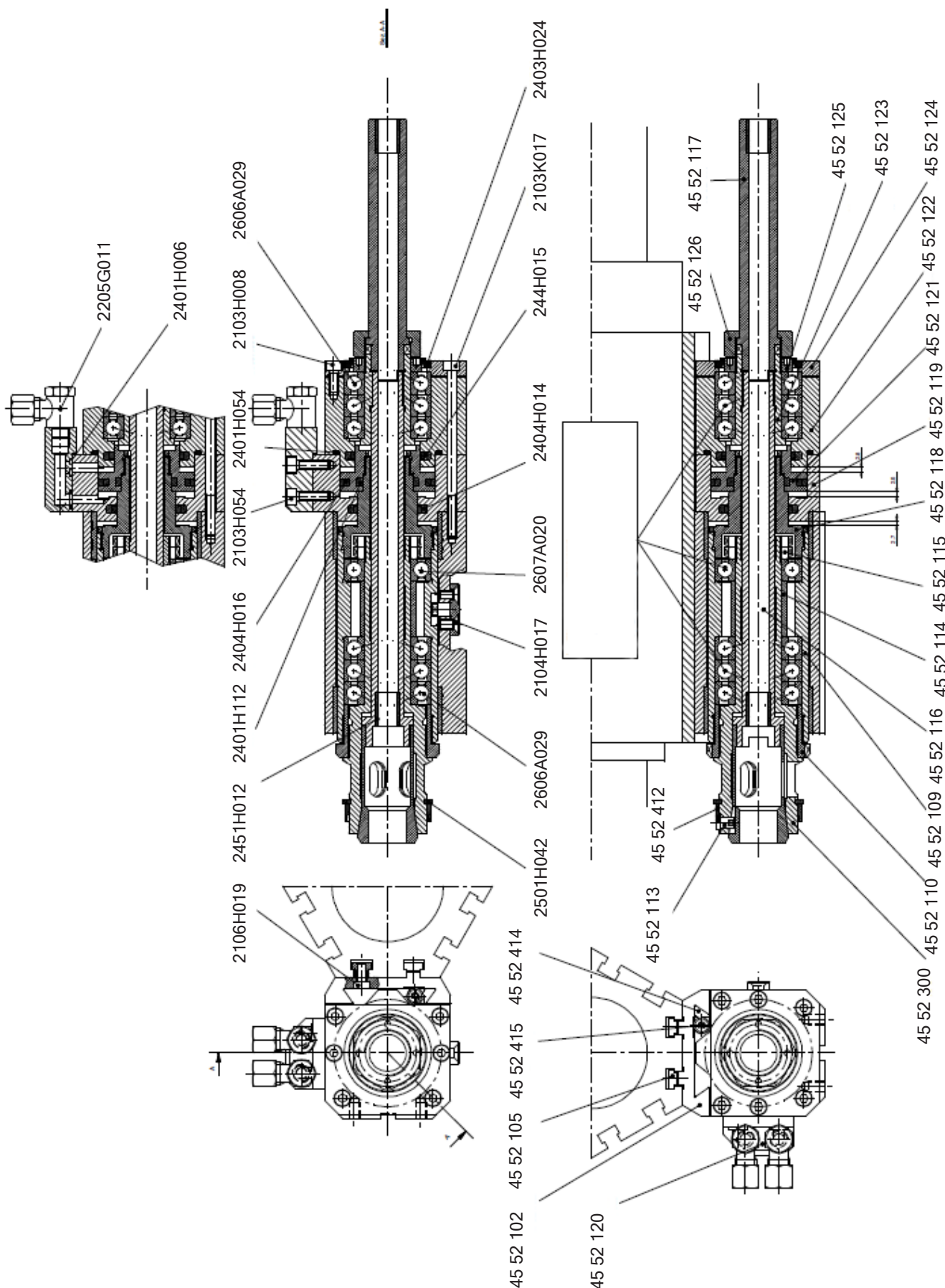

Coulisse double mécanique pour pos.6 et pos.3

Coulisse double mécanique pour coupe et reprise arrière

Réf : SC 45 11 002

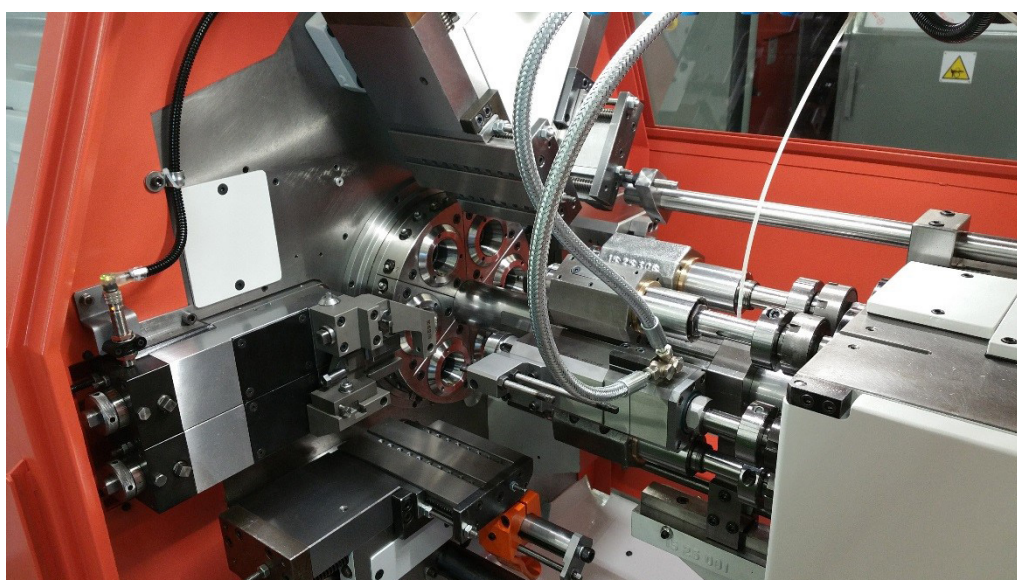
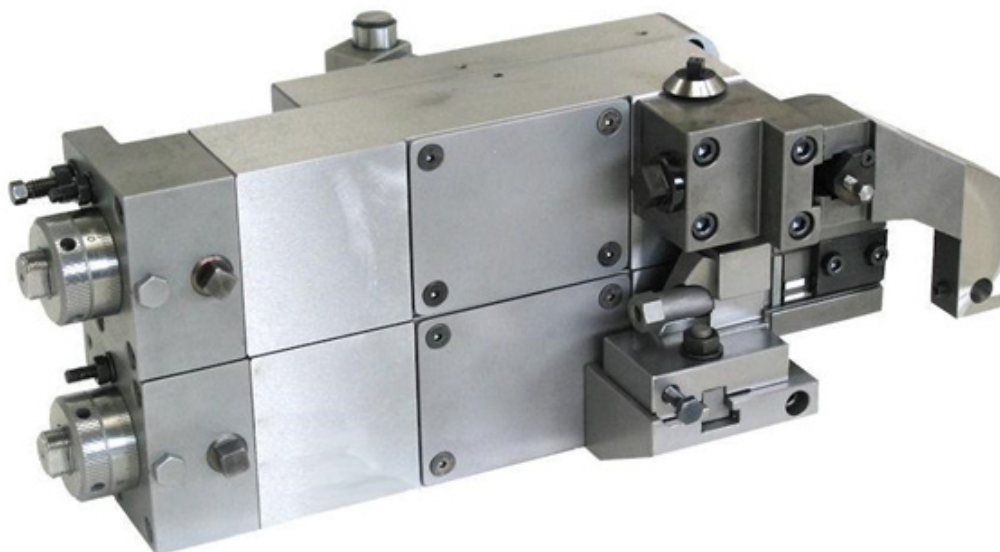

Arrêtage Pick-up pos.6

Réf : 30 23 18 00



Pick-up pneumatique 1ère génération



Commande de bloc central

Réf : 31.27.001

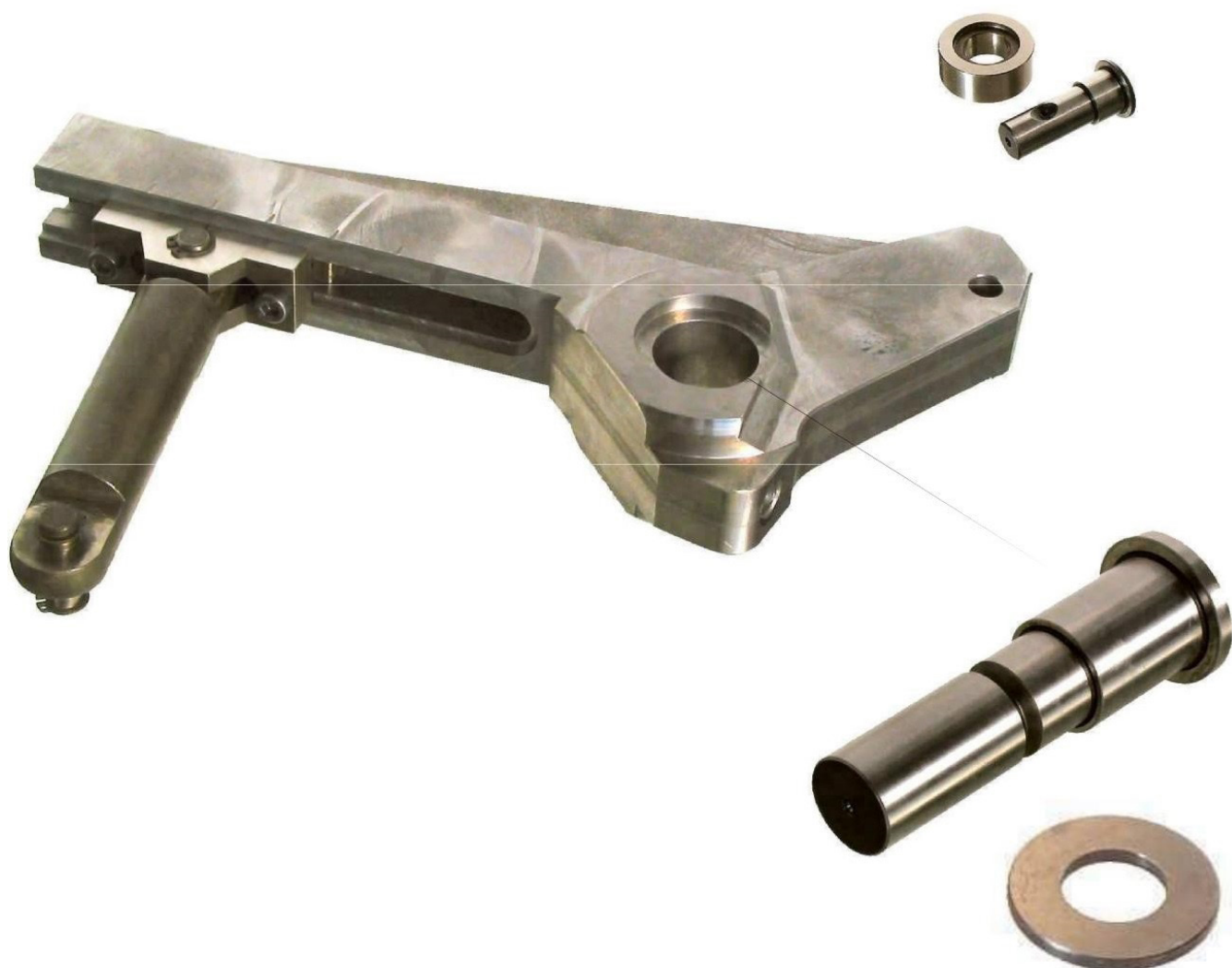

Tubes de serrage et d'avance passage 25



Serrage AS 20



Mécanisme de serrage spécial

Option: Serrage renforcé SACO AS/GS/GM20

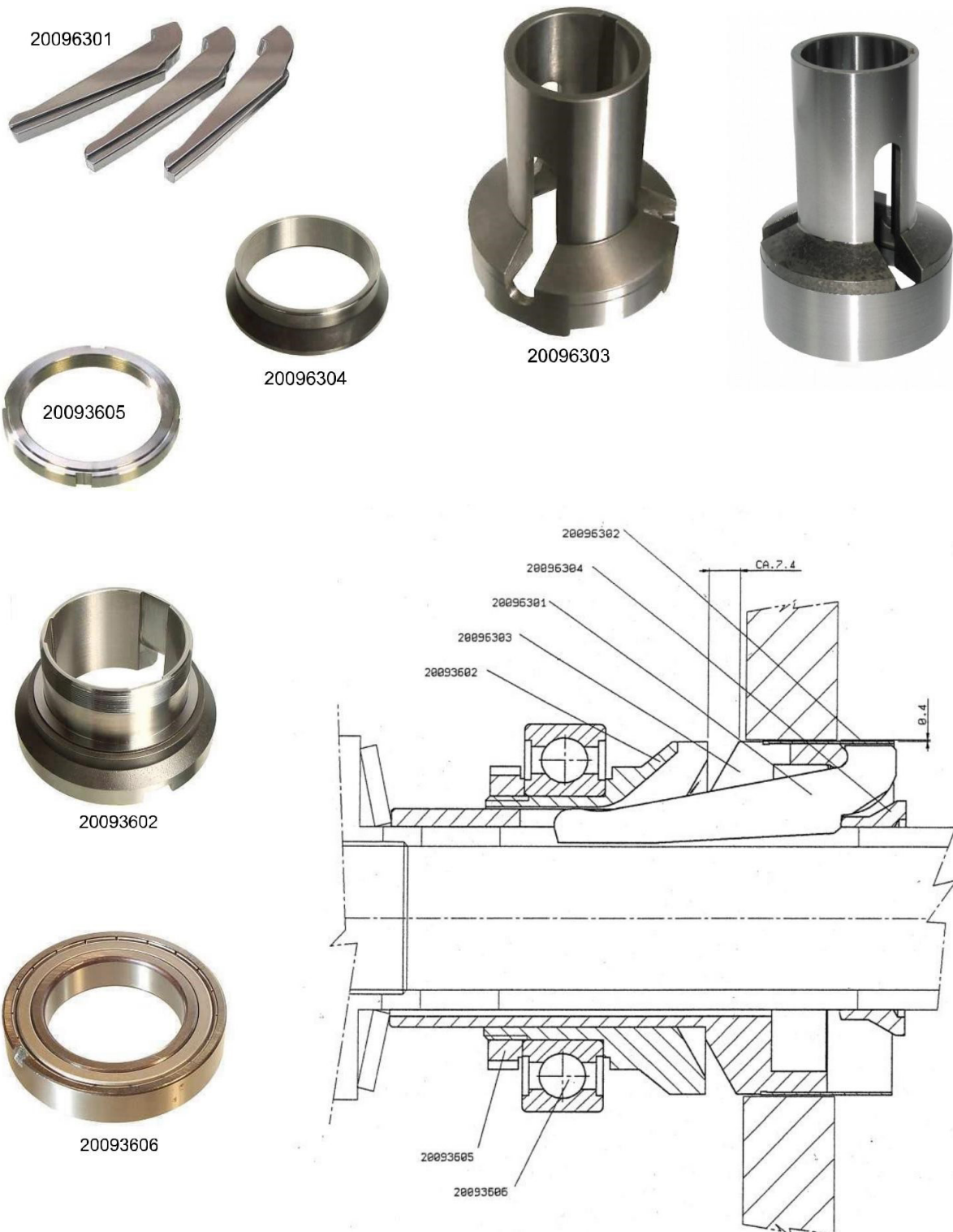

Serrage GS 20 – GM 20



Serrage + Avance passage 20 mm



Machine arrêtage de broche passage 20 mm

Double embrayage mécanique

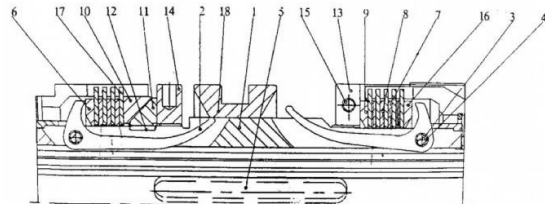

07.23.70
Double embrayage mécanique

08.53.152
Tube d'alimentation plus long pour
la machine arrêtage de broche



08.53.151
Tube de serrage plus long pour
machine arrêtage de broche

Bras de reprise pos.6

Réf : 31.42.101

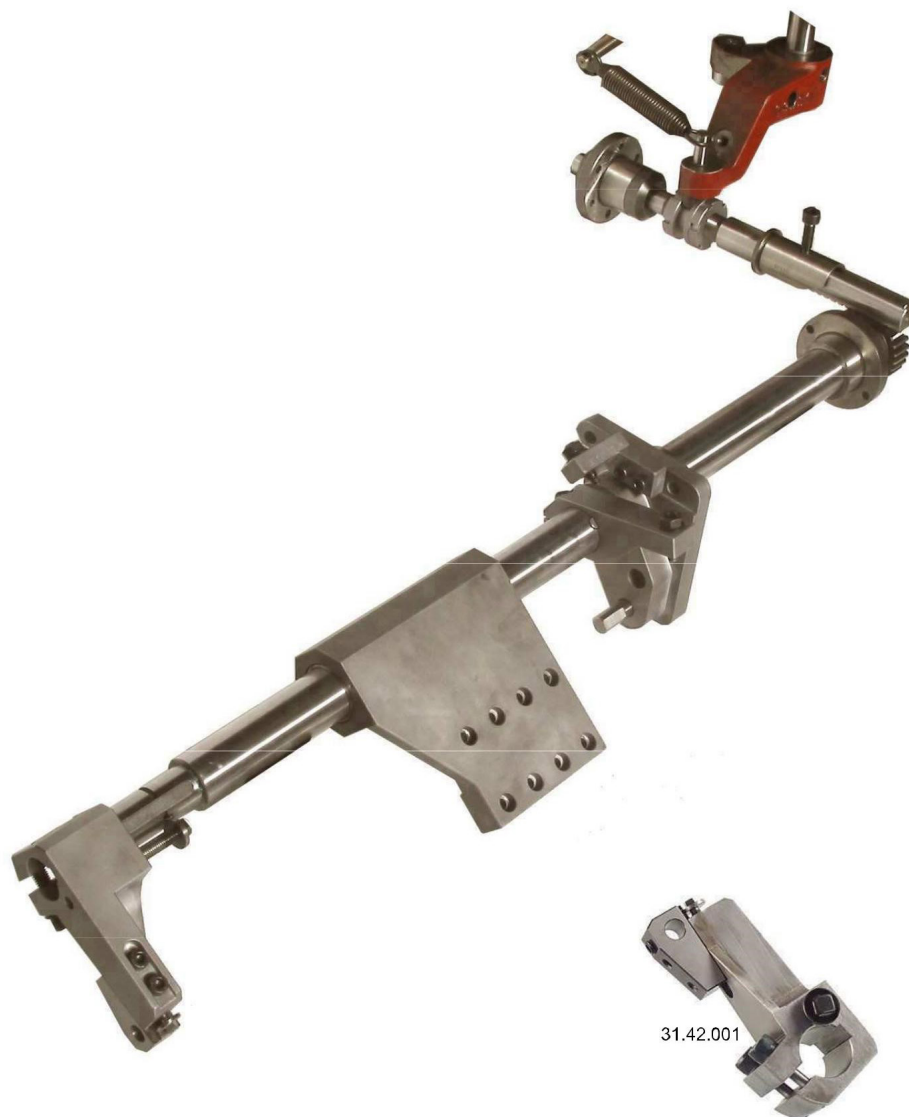

31.42.001

Axes / Galets



Boîte de vitesse / Production



Pignons

Z1	Z2
19	71
20	70
23	67
26	64
29	61
32	58
41	49

08.10.501

PIGNONS DE PRODUCTIONS

Z1	Z2
27	63
29	61
30	60
32	58
38	52
40	50
41	49
42	48
43	47
44	46



08.10.401

PIGNONS DE VITESSE ET RAPPORTS TARAUDAGE

Taraudeur

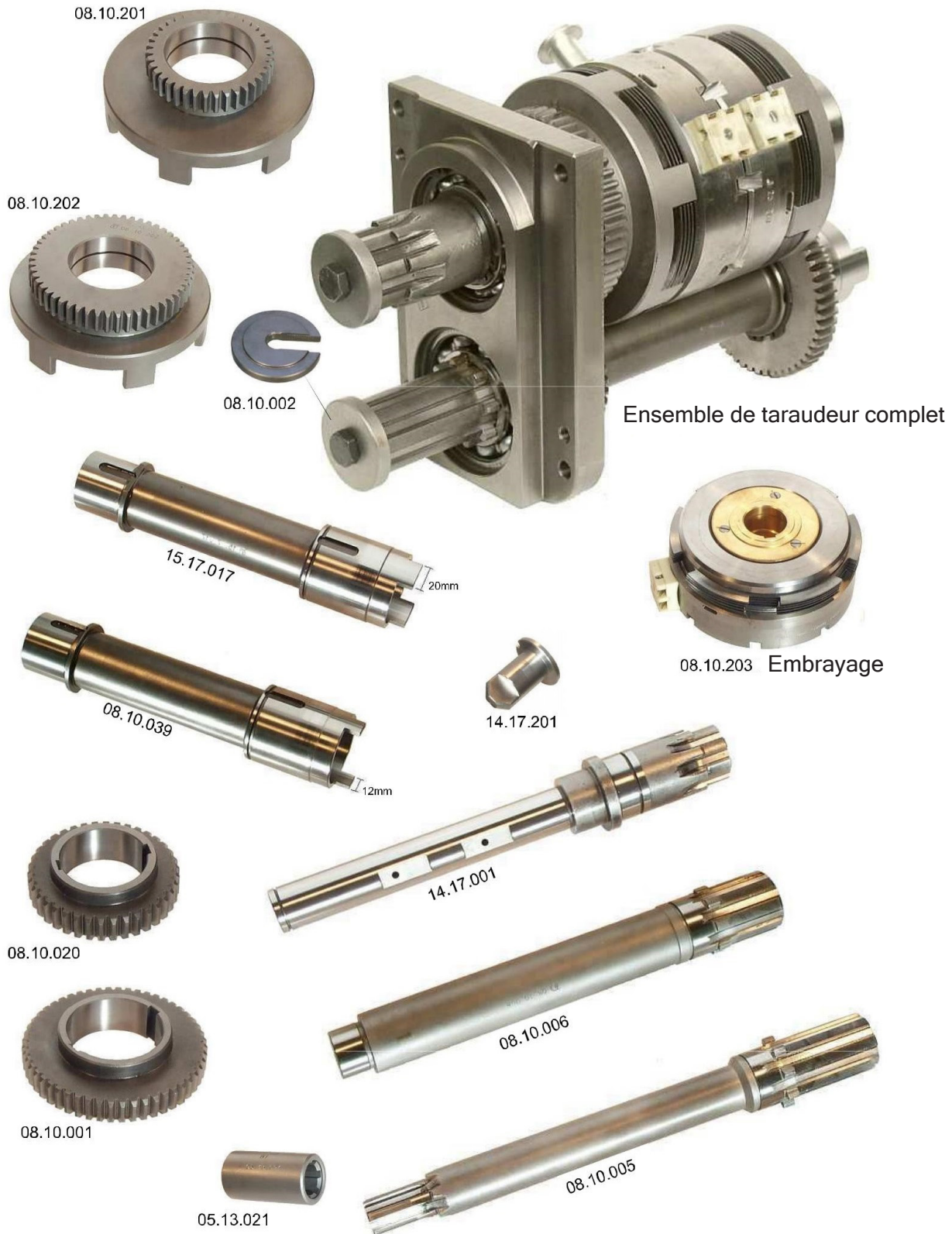

Leviers de coulisses

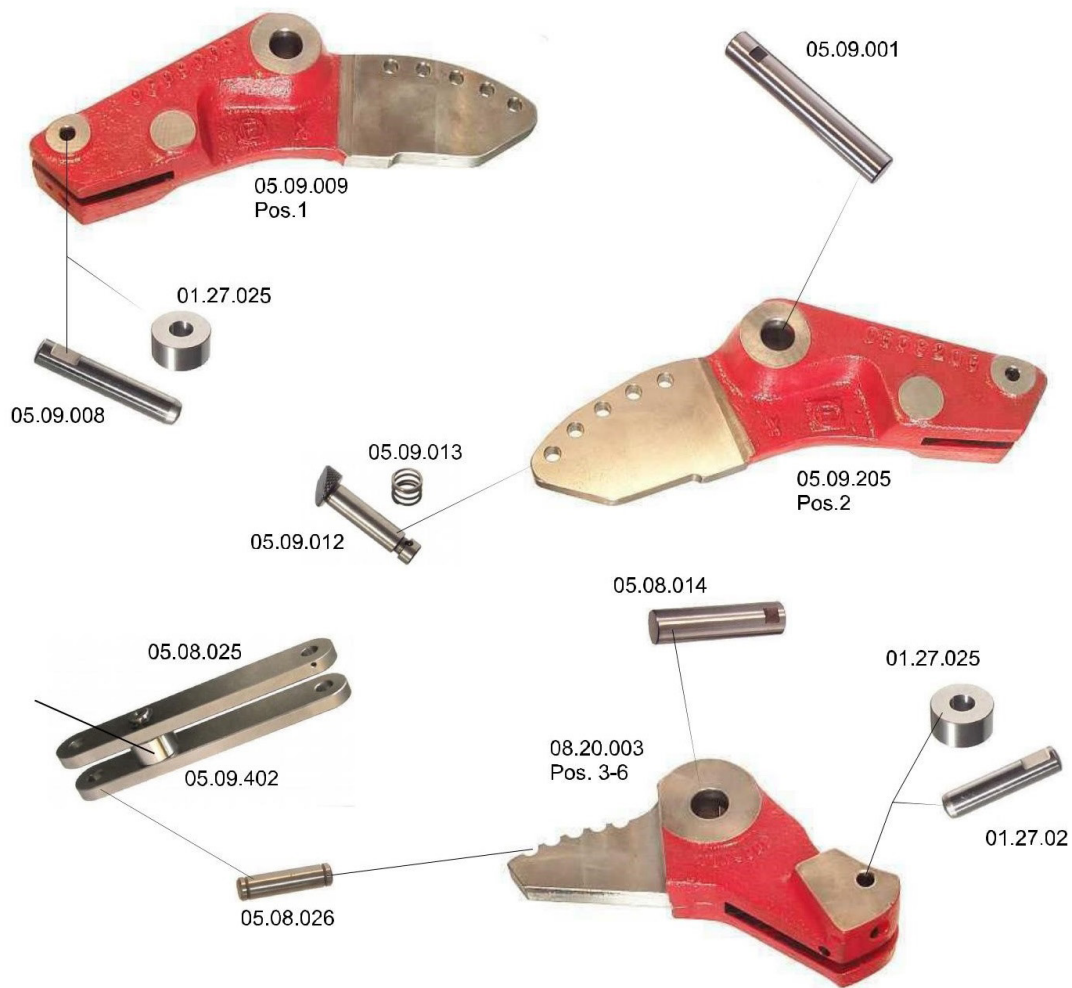

05.08.008 M10x1.5



08.22.003 M10x1.5



08.22.005 M10x1



01.27.306



01.29.033



05.09.011



05.09.011

Leviers de coulisses

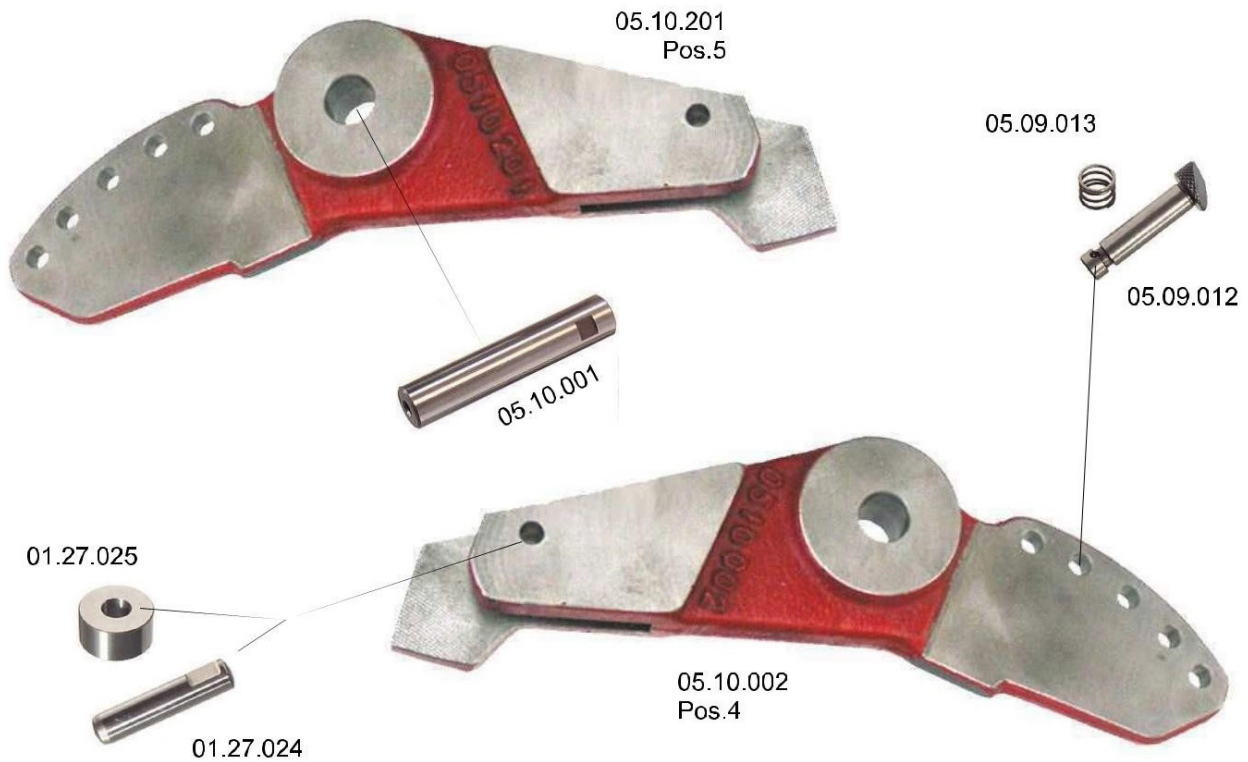

Option :
Leviers de chariots pos.4 et pos.5 pour têtes à rouler

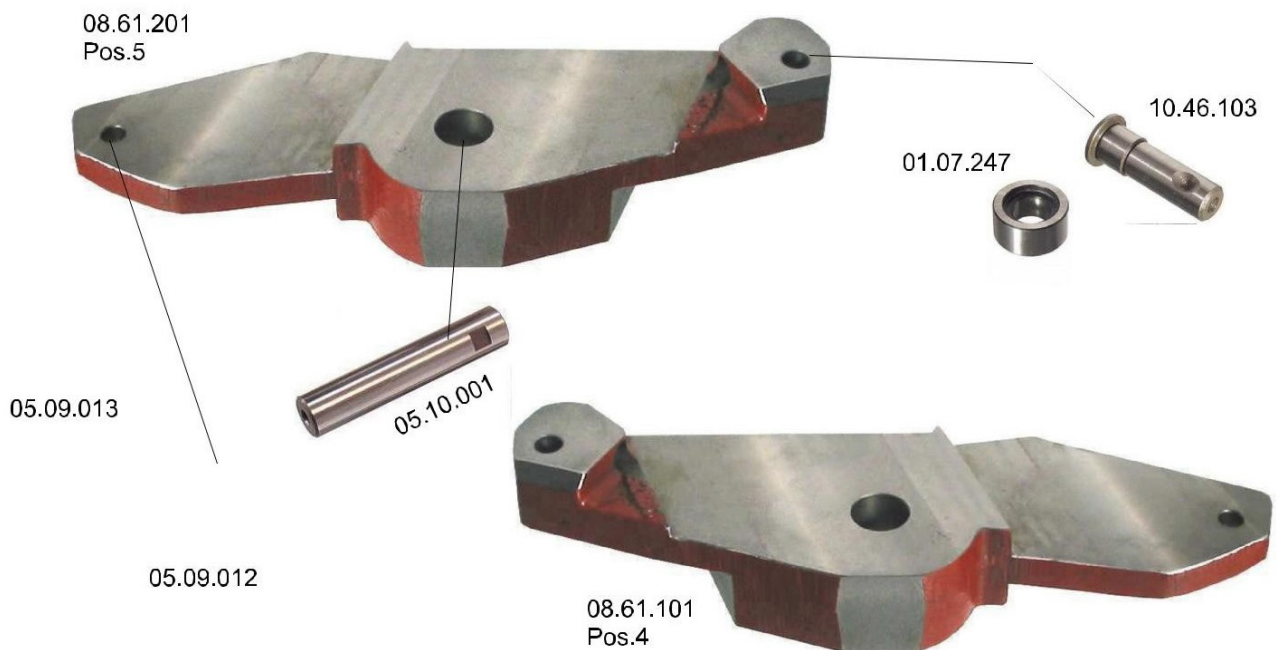

Commande axiale poste 1/2/4/5



15.21.101 AS/GS20
31.21.105 GM20



15.21.201 AS/GS20
31.21.106 GM20



15.22.008



15.22.007



15.22.009



15.21.108



15.21.109

15.22.001

17.01.513



15.21.106

08.40.019



15.21.107



Ø20

05.25.654



06.07.009



15.21.305



15.21.303



15.21.104



31.22.116



Ø24

Commande axiale



08.06.308 pos. 1-2



05.09.109 pos. 4-5



15.21.304



14.21.403



01.34.907



15.21.102 pos. 4-5



15.21.301 pos. 1-2



15.21.105



15.21.110



15.21.651
GS20-GM20
pos. 1-2



05.09.451



15.21.111



15.21.652
GS20-GM20
pos. 1-2



15.21.302
AS16-AS20
pos. 1-2

11.09.207
AS16-AS20
pos. 1-2

15.21.103
pos. 4-5



11.09.101

Option: Commande axiale

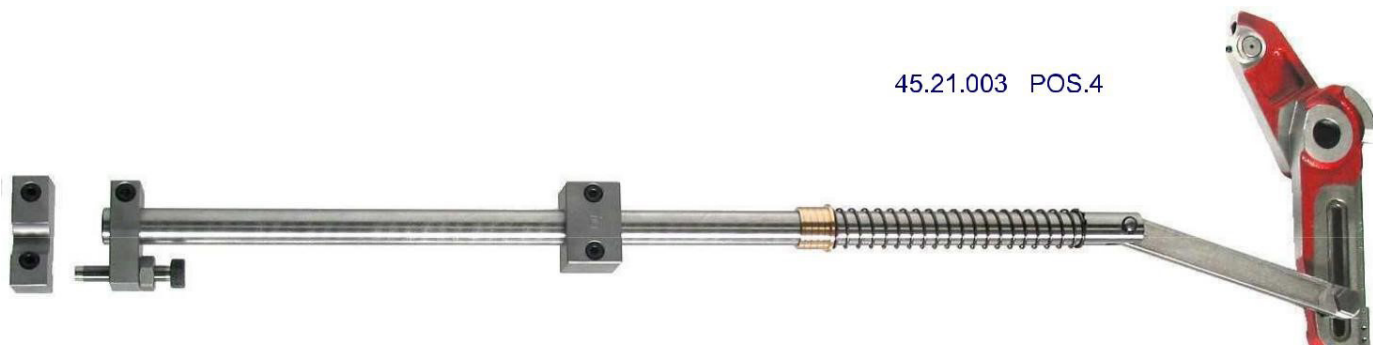

45.21.003 POS.4



45.21.004 POS.5



45.21.002 POS.2



45.21.001 POS.1

Croix de malte



Tambour transversal



Arbres à cames



Broches de poussée / Lunettes



Leviers de broches

Pos. 1-6
08.07.002 GS20
31.22.112 GM20



15.22.008



15.22.007



15.22.009



05.25.654



08.40.019



15.22.001 GS20
31.22.116 GM20



06.07.009



06.07.010



Pos. 2-3
08.07.004 GS20
31.22.113 GM20



01.11.025



01.11.026



Broche d'entraînement



Broche principale



Barillet broches principales



Anneau de ravitaillement



01.06.606



Secteurs ravitaillement



15.03.001



08.26.102



15.60.304



15.60.303



15.60.305



08.03.013

14.12.001



Butée de barre



01.07.247

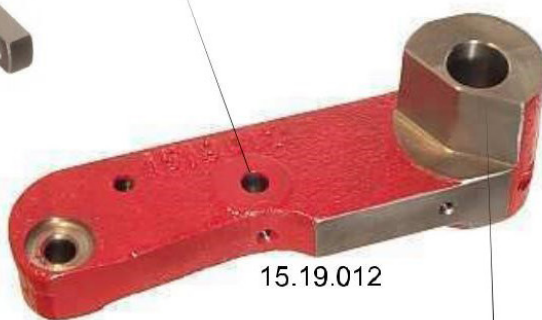

Pompe graissage à perte

Distributeur de graissage



VOGEL MFE5



VOGEL 34-34

VOGEL 34-24



Disques d'embrayages

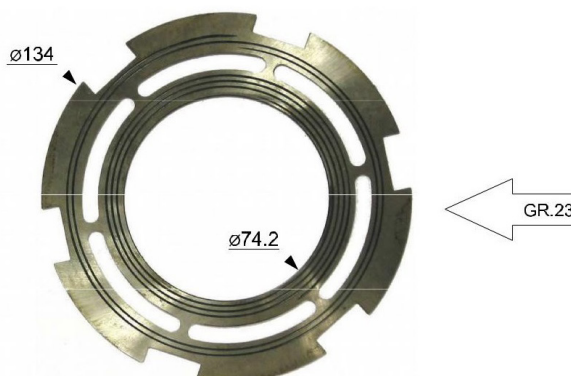
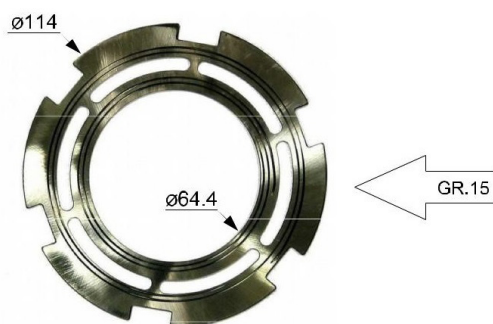
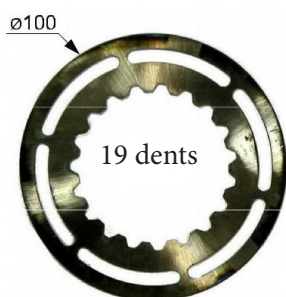
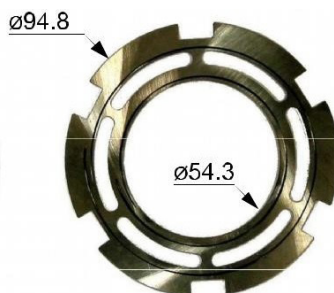
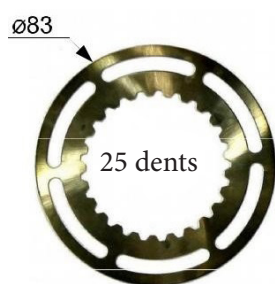

Votre partenaire pour l'équipement des tours automatiques



Disposant d'une grande expérience et moyens techniques importants, Tajmac-France vous propose la fourniture des appareillages, la révision partielle, la reconstruction complète de vos tours Gildemeister, ainsi que l'assistance sur site.

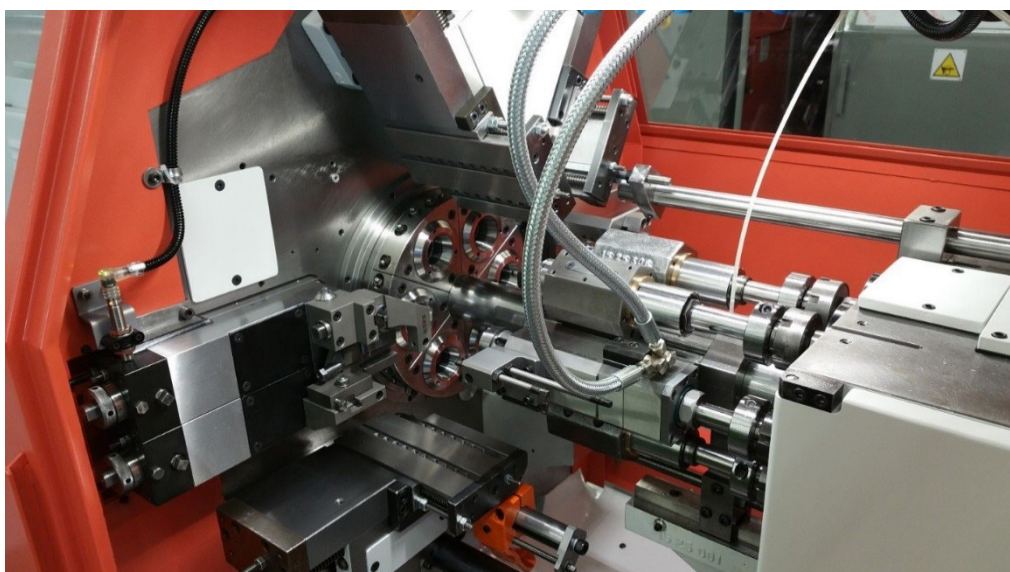

Votre partenaire pour l'équipement des tours automatiques

- Appareillages IMG, SACO pour les tours GILDEMEISTER, WICKMAN, MORI-SAY, SCHÜTTE et TORNOS.

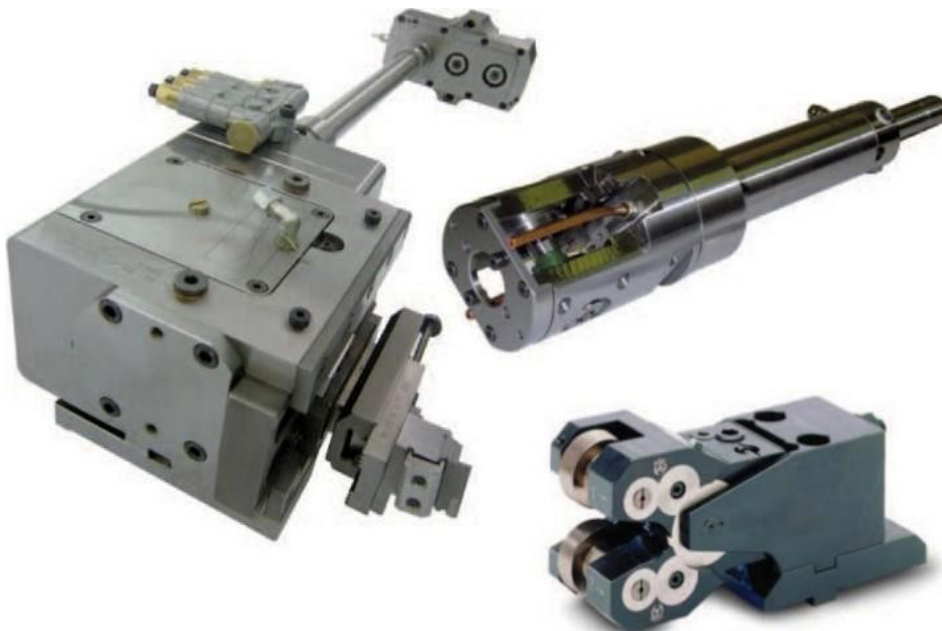

- Pincas de serrage, pincas d'avance, pincas pick-up pneumatiques / hydrauliques pour les tours multibroches GILDEMEISTER et multibroches autres marques, pincas embarreurs.





TAJMAC - FRANCE



85 Rue Marie Curie
ZAC des Grands Bois
74130 VOUGY

Tel. (+33)4 50 34 00 41
Fax. (+33)4 50 34 04 43

www.tajmac-france.com
info@tajmac-france.com

